

As you are now the owner of this document which should have come to you for free, please consider making a donation of £1 or more for the upkeep of the (Radar) website which holds this document. I give my time for free, but it costs me money to bring this document to you. You can donate here <https://blunham.com/Radar>

Do not upload this copyright pdf document to any other website. Breaching copyright may result in a criminal conviction and large payment for Royalties.

This document was generated by me, Colin Hinson, from a document held at R.A.F. Henlow Signals Museum which is believed to be out of copyright or Crown Copyright. It is presented here (for free) under the Open Government Licence (O.G.L.) if under Crown Copyright and this version of the document is my copyright (along with the Crown Copyright) in much the same way as a photograph would be. It should be noted that most of the pages are identifiable as having been processed by me. If you believe the original document to be under copyright, please contact me.

The document should have been downloaded from my website <https://blunham.com/Radar>, or any mirror site named on that site. If you downloaded it from elsewhere, please let me know (particularly if you were charged for it). You can contact me via my Genuki email page: <https://www.genuki.org.uk/big/eng/YKS/various?recipient=colin>

You may not copy the file for onward transmission of the data nor attempt to make monetary gain by the use of these files. If you want someone else to have a copy of the file, point them at the website (<https://blunham.com/Radar>). Please do not point them at the file itself as it may move or the site may be updated.

I put a lot of time into producing these files which is why you are met with this page when you open the file.

In order to generate this file, I need to scan the pages, split the double pages and remove any edge marks such as punch holes, clean up the pages, set the relevant pages to be all the same size and alignment. I then run Omnipage (OCR) to generate the searchable text and then generate the pdf file.

Hopefully after all that, I end up with a presentable file. If you find missing pages, pages in the wrong order, anything else wrong with the file or simply want to make a comment, please drop me a line (see above).

If you find the file(s) of use to you, you might like to make a donation for the upkeep of the website – see <https://blunham.com/Radar> for a link to do so.

Colin Hinson

In the village of Blunham, Bedfordshire, UK.



AIR TRAINING CORPS GAZETTE

PUBLISHED FOR THE AIR LEAGUE OF THE BRITISH EMPIRE, 1A PALL MALL EAST, S.W.1 (TELEPHONE ABBEY 5041)
BY THE ROLLS HOUSE PUBLISHING CO. LTD.

VOL. IV NO. 8

Edited by Leonard Taylor

AUGUST 1944

The Chief Commandant's Visits

IN the last month I have visited units in seven of our eleven A.T.C. Commands, inspecting both school and open units.

Seeing these different units at work on varied activities and under many different conditions, I find myself becoming able to compare with reasonable accuracy standards of efficiency throughout this Corps. I can say without hesitation that the standard generally is level—and high. That is a matter for congratulation, and for thanks to all for the work which lies behind this result.

Field Day

The second annual "Field Day" of the Herefordshire Squadrons, held at an R.A.F. station in that county, was a particularly useful demonstration of A.T.C. work and play. Group Captain C.A. Hoy, M.C., the station commander, and his staff made the 400 or so cadets very welcome. In the morning a series of inter-squadron competitions taxed the cadets' knowledge of their syllabus; and after lunch the units put up some good performances in a competitive sports meeting. The winning squadron on the day's events was 124 (Hereford City), which received, at an impressive ceremonial parade, the silver cup presented by the R.A.F. station, a fine gesture of appreciation on the part of the R.A.F. station to the A.T.C. All enjoyed themselves thoroughly, both A.T.C. and R.A.F., thanks very largely to the Air Force. I strongly commend this form of "senior and junior" service co-operation to other units as a first-rate way of fostering *esprit de corps*.

Band Contest

Under the organisation of Mr. J. H. Iles, O.B.E., the first A.T.C. Band Contest took place at Belle Vue, Manchester, on June 11th, 1944, and I was very glad to have had the opportunity of witnessing the contest and of taking the salute. Martial music has always existed wherever there are fighting men; and the 16 A.T.C. bands who, despite war-time difficulties, were able to enter seemed to symbolise the brave spirit of the A.T.C. The smartness of those on parade and their disciplined bearing made a very good showing, and I was particularly impressed by the drum section of the Bradford

Wing band. The full results were published in last month's *Gazette*.

Synthetic Training Appliances

In South Wales, during a three-day tour, I saw units at their work and on parade, all showing a high standard of efficiency. Previously I had been with the Southend Wing, and there saw something of their "synthetic" training

to Perry Bar (Birmingham) and Stourport. Units in both these districts are to be congratulated on impressive ceremonies. I was also able to spend a short time with the B.S.A. squadrons and see their headquarters, which testify to the interest which this great firm takes in its A.T.C. units.

Physical Training

At Bryanston, Dorset, and Bishop Wordsworth's, Salisbury, school units showed their aptitude at physical training during my visits. The latter squadron's parade formed part of the school's Founder's Day celebrations.

All these inspections have shown me that the Air Training Corps is continuing to put great effort into its training—disciplinary, academic and physical—and it is getting great value therefrom.

To you all I would like to say "A good show—and keep it up."



The late Pilot Officer Cyril Joe Barton, aged 23, who was posthumously awarded the V.C. for "unsurpassed courage and devotion to duty in the face of almost impossible odds."

NATIONAL SERVICE

Whilst this number of the *A.T.C. Gazette* was in preparation it became necessary for the Air Ministry to place certain airmen on the deferred-service list of airmen accepted and attested for aircrew at the disposal of the Ministry of Labour and National Service for transfer to the Army or to some other form of national service essential to the successful prosecution of the war. Thus it was not possible to give advance information of this measure to the Air Training Corps, a measure which, it is admitted, will be bound to have caused comment throughout the Corps. A letter on this subject has been sent to the chairmen of committees, A.T.C. commandants, and officers commanding A.T.C. squadrons and flights. I feel confident that cadets themselves and the officers and instructors responsible for their training will regard their many hours spent voluntarily in training as a real contribution to the victory which lies ahead of us and which we must work our utmost to achieve as soon as we can.

E. L. GOSSAGE, Air Marshal,
Chief Commandant and Director
General, Air Training Corps.

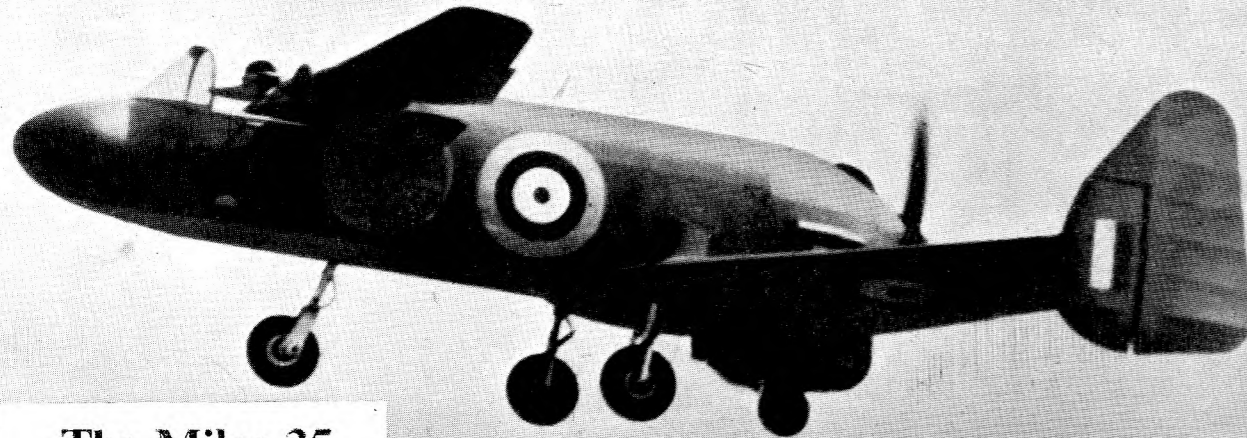

The Miles 35

The Miles 35, a tandem-wing aeroplane in which the smaller of the two wings is in front, giving the pilot an unrestricted view. The wing span is smaller than on orthodox aircraft, making it particularly suitable for shipboard operation. The photograph above is of the scale model, which is now flying. The diagram below illustrates the projected full-sized machine. Mr. Miles also hopes to produce a large six-engined bomber or commercial transport on these unconventional lines as shown on page 16

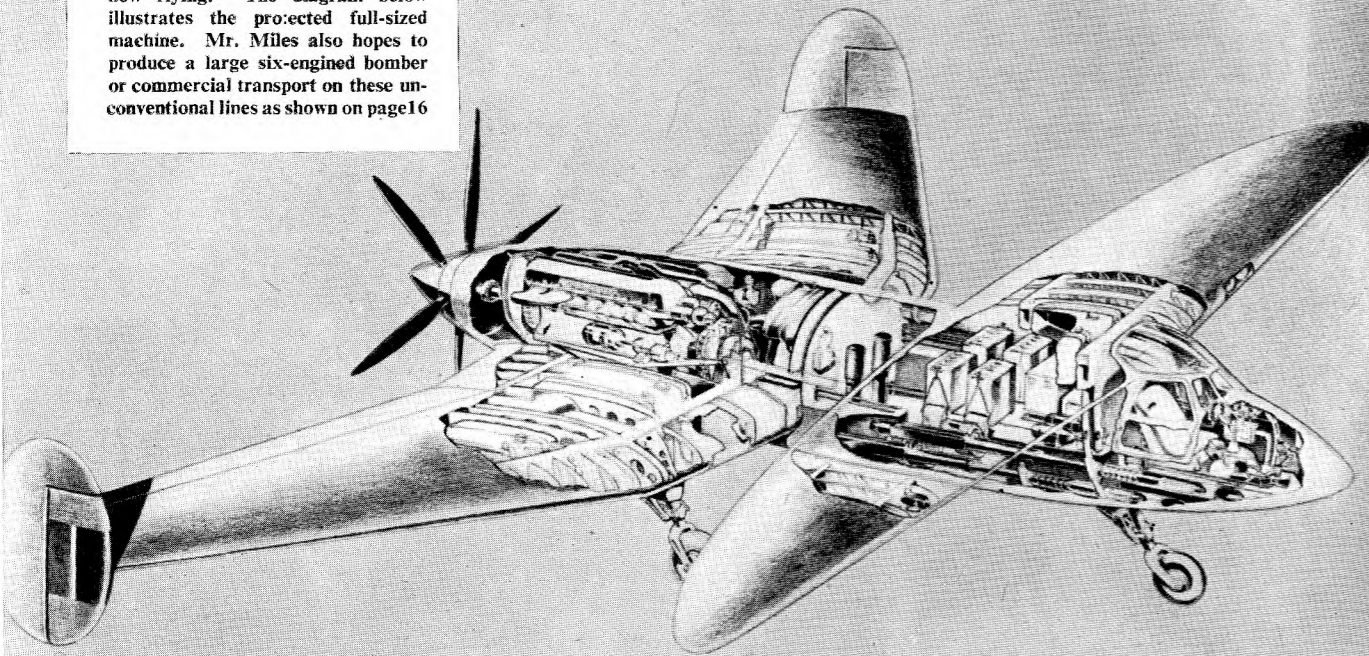

appliances, visiting also the headquarters of their very scattered flights.

A.T.C. Calling

Later, at Burnley, Lancashire, I was able once again formally to open the "A.T.C. Calling" exhibition—still a fine show and still doing good work. In the North-West also I was able to see units in Blackpool, Preston and Manchester, including the very keen squadron of deferred-service men at the Manchester College of Technology.

Colour Presentations

Two Colour Presentations took me

HELLCATS



Grumman NAVY FIGHTERS

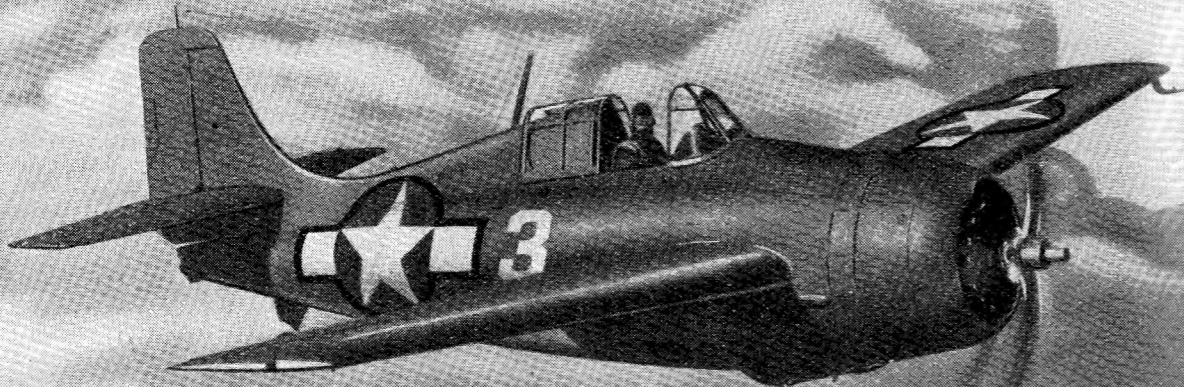
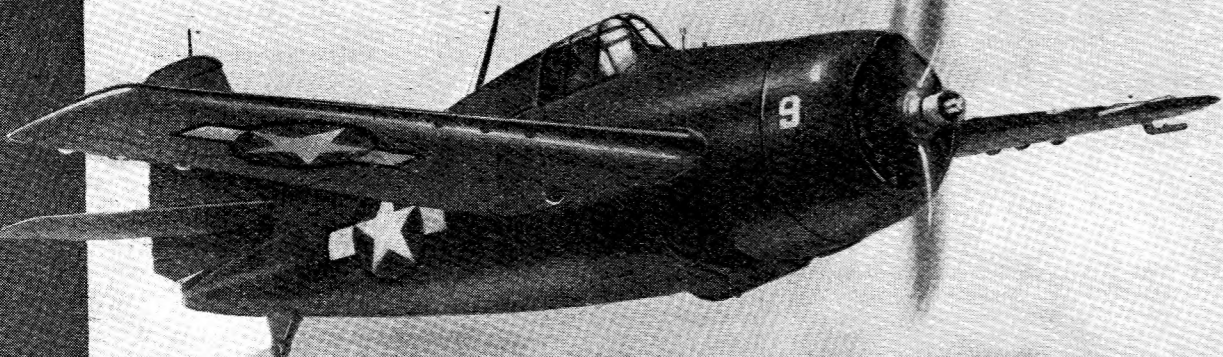

WILDCATS



THERE were seven of them—*Ark Royal, Courageous, Glorious, Eagle, Hermes, Furious and Argus*. Seven ships with not much more armour between them as is to be found round the average biscuit tin. Seven ships, and, of course, the aircraft which went with them—say, 250 aircraft. The fastest of these aircraft had a top speed of just over 200 m.p.h., and it was armed with four .303-in. machine-guns. It was the Sea Gladiator. The rest were Swordfish and Skuas, of which the Swordfish was the slowest aeroplane in the Service, as well as being one of the best.

It wasn't much with which to enter the greatest war of all time—not much for the nation which reckoned itself to lead the world in sea-power. It would not have been much even for a neutral. Yet that was our strength in 1939, and by burning the paint off the funnels and flying the aircraft until the engines were ready to drop out of the airframes, it was made to do.

Now it is 1944, and the Army is in France again and the oceans are as

nearly free as ever the oceans can be in time of war. It would seem as though there is just one more great sea battle to fight, one more clash before the ships can return to port for a long-deferred boiler-scraps. One battle . . . and maybe it is going to be the greatest sea battle of all—the battle of the Pacific against the last enemy.

Let me try to paint a picture of what it may mean. First there is the setting, for which words are poor materials for so vast a canvas. A thousand islands—palm-trees, pill-boxes, coral reefs, malaria—some of the islands as big as England, some as small as Trafalgar Square, but the majority of them fortresses to be taken by storm. And water in between—five miles deep and immense in area. If it were dry land and you motored round it, it would take 25 days at an average speed of 40 m.p.h. for 12 hours a day. It is an arena for a Grand Fleet and as many hundreds of carrier-borne aircraft as can be mustered, a battleground for the Navy, with the assault forces entirely dependent on ships and ships' aircraft for transport and cover. If it were possible to muster 2,000 warships and 5,000 first-line naval aircraft, it would not be one too many.

The Battle Has Begun

The battle has, of course, already begun. Our allies, the Americans, have made a magnificent start, and to an increasing extent we are helping them. With victory in the West it must see the full weight of our sea-power in fulfilment of the Prime Minister's undertaking to bring to bear in the Pacific all our resources. The combined striking power of the British and American fleets is greater than any the world has yet seen.

The tactics to be employed are not

the concern of this article, although in passing it may be pointed out that the policy of breaking down the enemy's island defences one by one is for ever narrowing the ring which is about them. Our concern is more with the British contribution and what it is likely to be. Here again details can obviously not be published, but the inference that they will include a great weight of naval air power leads to the question of how great. The seven aircraft carriers with which we entered the war, and of which five have been sunk, obviously do not represent the striking power today. Its exact composition is unknown, but it is interesting to note that the Americans recently announced that they had a fleet of over 65 aircraft carriers; and upon this one can make the comment that in the matter of sea-power it has not been the tradition of the British to be far behind.

The names of several 22,000-ton Fleet carriers have been mentioned in communiqués—the *Indomitable, Victorious, Illustrious* and *Formidable*, while two other great ships were announced in naval programmes published immediately before the war—the *Indefatigable* and the *Implacable*. While there is no further information as to whether they have come into service, it is clear that with the pre-war carriers which did not fall a prey to the enemy we have now a powerful force of the largest type of ship.

Each of them carries a big striking force of first-line aircraft, and has a speed in excess of 30 knots.

Escort Carriers

And since those dark days of 1939 a completely new class of carrier has been introduced, and obviously in large numbers. Conceived originally as a counter-measure against the sub-

Corsair fighter landing on the deck of a Fleet Air Arm escort carrier.

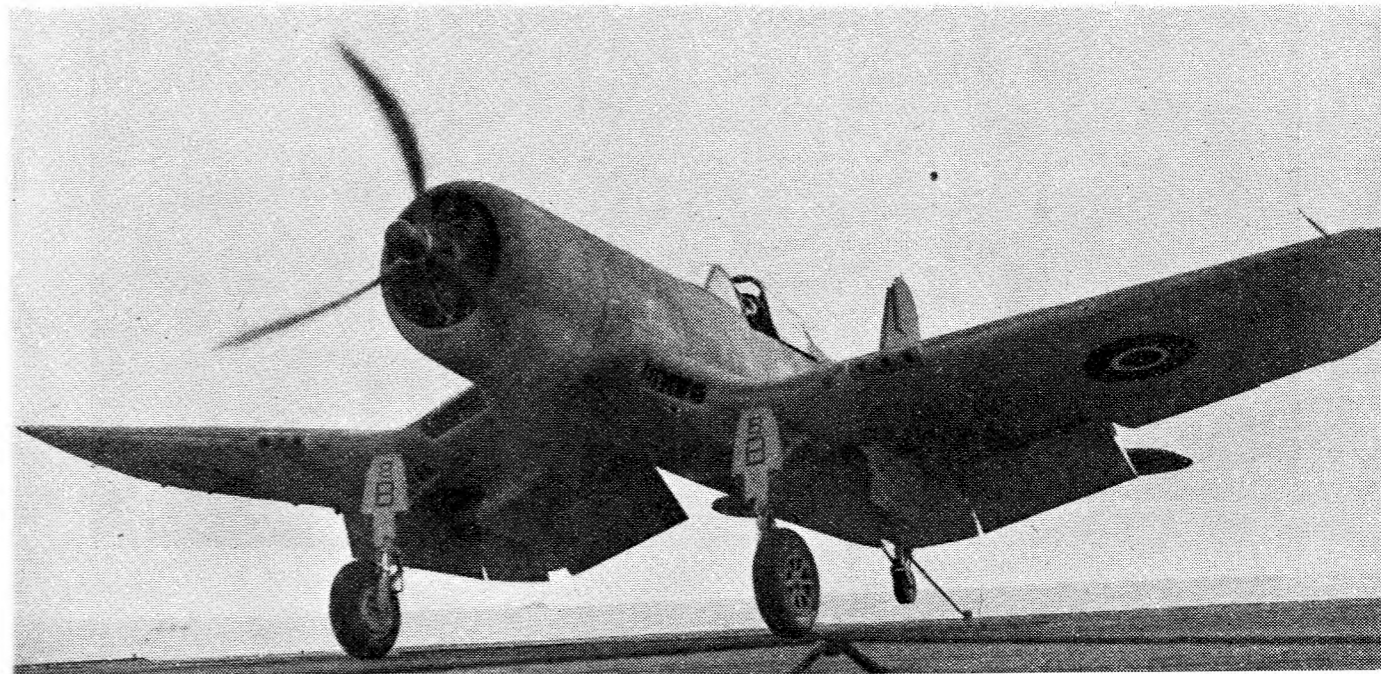

marine, it has assumed roles of every class, including assault duties (such as were carried out at Salerno and elsewhere). Under the name of escort carriers the striking power of naval aircraft has been multiplied again and again, and their introduction has proved one of the most successful experiments of the war.

Originally they were fast merchant ships whose upper-works were stripped and replaced with a flight deck approximately 450 feet long (the deck of a fleet carrier is approximately 750 feet). The first of them was actually a captured German merchantman of 5,600 tons which, after 14 weeks of brilliant work on a Gibraltar convoy, was finally a victim of a concentration of German submarines which were sent out to get her at all costs. The later carriers were American conversions, and later still we not only converted our own, but built special hulls for the job.

The role of such ships as these must be, with the Fleet carriers, one of incalculable importance in the Pacific theatre.

The Aircraft

The aircraft which they mount have been the subject of no less notable developments, both as regards performance and the weapons they carry. It is known that we go into battle today with a list which includes four distinct types of modern high-speed fighter—the Seafire, Wildcat, Hellcat and Corsair, while our torpedo-bombers have been reinforced with equally powerful newcomers in the form of British

Barracudas and American Avengers.

It may be said that naval fighter speeds have increased since the outbreak of the war from a class capable of 200 m.p.h. to one which is in excess of 350 m.p.h., with an increase in engine power from roughly 1,000 to 2,000 h.p., thereby bridging the gap which originally existed between shore-based and carrier-borne aircraft. The weight of their armament has enjoyed a corresponding increase, and the Seafire has been announced as being equipped with two cannons and four .303 machine-guns. The other fighters, each of which is supplied under lease-lend terms by America, have a very powerful armament of .5 machine-guns which are a specialised development of American aviation with a very impressive record in action. It was announced recently, for instance, that Hellcats fitted with these guns destroyed 141 Japanese aircraft for the loss of only 17 American. In British hands they have already done extremely well in action.

Torpedo-bombers have, like the fighters, become faster and more powerful. The newly introduced Barracuda, blooded in the *Tirpitz* action, proved itself to be a potent weapon as a dive-bomber. In this capacity alone it was clear that a great advance had been made both in the weight of bombs carried and their explosive effects. So far no news is available of the Barracuda as a torpedo aircraft, but its speed over the Swordfish must make it a powerful weapon, with a greatly increased range. As for the Avenger, the success achieved with

it by the Americans leaves little doubt as to its qualities.

Joint Action

The combination of the best British and American aircraft is a happy one. The Americans have concentrated on giving their machines a great range, more than 1,400 miles being within the flying reach of both their torpedo bombers and their fighters when fitted with long-range tanks. This is a quality of special significance in the Pacific.

Experiences have already been gained of joint action between the two naval air forces and they have been happy and successful. First, H.M.S. *Victorious* worked in the Pacific as partner to a great American carrier in September 1943, under the command of Admiral Ramsey of the U.S. Navy. Squadrons were actually exchanged while at sea between these two ships, and flew operationally from each other's decks. This was followed by a combined strike at Sabang, in which British and American carriers inflicted grievous losses on the Japanese, losing, themselves, only one aircraft, whose pilot was picked up by one of our submarines under the nose of the Japanese shore batteries.

It can already be said that any naval air action in the Pacific is now on so large a scale that it compares in striking power with the Luftwaffe in its 1940 prime. While the U.S. and the British Air Forces combine today to form irresistible spearheads over the fields of Normandy, another combination of the naval air forces is expected to be equally decisive in the Pacific.

Follow Your Leader

by H.C.

BUT what sort of leader?

When I hear a man described as a "born" leader, I only hope sufficient people have been born to follow him, especially if he is a leader of fashion, and turns up in evening clothes of purple velvet when we are in white tie and tails.

Lots of men are born to lead. Some to lead out of turn. Others must be first in every queue. But leadership is not the art of going in front; there is too great a chance of going alone. It is a personal insurance that to the bitter end there will be followers at your shoulder who will keep going only because you yourself are in front. Leadership of this sort exerts its influence long before D-day; as soon, in fact, as your personality impresses itself on others; and in case you think personality is something you should force on people's notice, let it be understood that it cannot be acquired at will. Personality means effect without affectation. It is the art of being noticed without butting in. Too many people are so busy flaunting their alleged personality that they get their effect solely by affectation, and are noticed only because they do butt in. Indeed, they do not have personality at all, but only a set of irritating mannerisms.

Where to Find Them

In discussing leadership from this starting-point, there is one thing to note, namely, that the ideal N.C.O. never makes the ideal officer, because his technique is adapted to an entirely different set of circumstances; so much so that he must use a different approach and another language. The N.C.O. lives with the men off parade; the officer doesn't. The best officers are found in chrysalis form amongst recruits who have not yet been schooled in non-commissioned traditions; in fact, amongst the file rather than the rank.

On the other hand, no black-coated worker should be looked upon as a potential officer merely because he stands in the ranks beside less reputable characters. Many of the black-coats are quite unsuited to lead anybody. Officers should be looked for amongst men with far vision and abundant sympathy; not amongst those who are either (i) pleased with the sound of their own voice, or (ii) afraid of using it.

Personality

The officer's main object is to gain the respect of men, and thus their devotion. The reason personality makes a good beginning is that men like to have officers they can carica-

ture. This not only keeps them amused during periods which might be dull, but gives them something to talk about animatedly to men of other units. An officer who is never talked about is a nonentity. As for battle, where leadership counts highest, it is the officer's subconscious insistence on the little foibles by which men knew him in training that keeps them cheerful and confident under murderous fire.

This is nicely pointed by the story of the sailor who, before battle at sea, looked into his officer's cabin and said, "Will you take your bath before or after action, sir?" This may give a picture of the perfect batman, but I claim it also gives a picture of the perfect officer *from the man's point of view.*

Understanding

Another quality the good leader needs is that of knowing what it is like to be in the ranks, *without saying so.* It is a curious sidelight on human nature that people who are in the ranks *now* are not interested in others who were in the ranks *then.* Besides, men like to think of their officers as having been officers always. They do not take a favourable view of the promoted corporal—the jumped-up gent. If the officer of high degree likes to remember the day when he himself experienced what his men are going through now, let him do so for his own guidance, and let him show his understanding silently and in some practical way. He should never (repeat never) explain to them how *he* always overcame their difficulties quite easily and how much greater his difficulties were.

Technical Skill

On the question of knowledge, no one expects the leader of an expedition to be its expert on every subject. Craftsmen are included in the team because they each have some special talent, and perhaps no other. The R.A.S.C. commander is not paid to spend half his day under a lorry. Neither is the gunner major worth his corn if all he can do is to fire the gun better than the next man. The captain of the ship has much more to do than steer it, and no Royal Air Force officer is required to be rear gunner, pilot or navigator of the same bomber, according to which job they chance to give him at briefing.

What every leader in every arm must aim at is a sufficiently wide theoretical knowledge to know whether the experts are doing their jobs. Whilst he himself should be such a specialist in one subject that he is outstanding among other officers, all of whom started with the same general qualifica-

tions. Thus only is discovered the one man who will not only lead his flight, but his wing.

Modesty

The really interesting type is the man who has obviously seen everything and done everything, but will never talk about it or say how he got his decorations or his scars. As soon as he starts to speak, uninvited, his attraction fades. And as soon as his stories, being too colourful, are disbelieved, attraction goes altogether, robbing the hero of majesty and the men of awe. Neither do men like leaders who use bad language, whether by way of command or making conversation. It is easy enough for an officer to employ any filthy words he knows, but very difficult for the man to use them back. I have heard commanding officers speak in the language of the gutter, thinking that only so could they impress their point. Some even thought it made for popularity. How wrong they were. What would they think if, after talking in that way to a man who was on a charge, he answered, "Not ruddy likely, cock"!

I will even say that no officer should talk to any man except in the mood in which he expects a reply. If he feels humorous, no harm is done, providing the man may make a humorous retort, but it is quite wrong for the officer to make a witty remark and then jump down the man's throat for making an even wittier answer. If you expect discipline, show it. The same if you expect devotion. The leader who is not devoted to his men is asking them for something he cannot give.

Manners

Then again, men have considerable contempt for bad manners in an officer, even though they may pass them in anybody else. They have a sound idea of what a leader should be. They sincerely wish to look up to him, and to point him out with pride to their relations. If they pay an officer the compliment of asking him to meet the missus it is not because they want to show off the missus but because they want to show off the officer; and it is heartbreaking if the officer fails, through stupidity, to do them credit. When the missus is not at her best she can be told about it. The officer can't be.

It is true, I think, that a man will not notice whether he keeps his own hat on in the house, but will be horrified if the officer does. He does not want his officer to be condescending, aloof, or familiar. He wants him to behave as he behaves to the men, and so show the missus why the men adore him.

I am afraid the ability to do this cannot be taught. A man either has the gift or he hasn't. But I can say that the man who has it will be the leader, and the other never will.

CONTINUED ON PAGE 18

A Seafire on the flight deck of H.M.S. *Furious*. H.M.S. *Duke of York* is in the background.

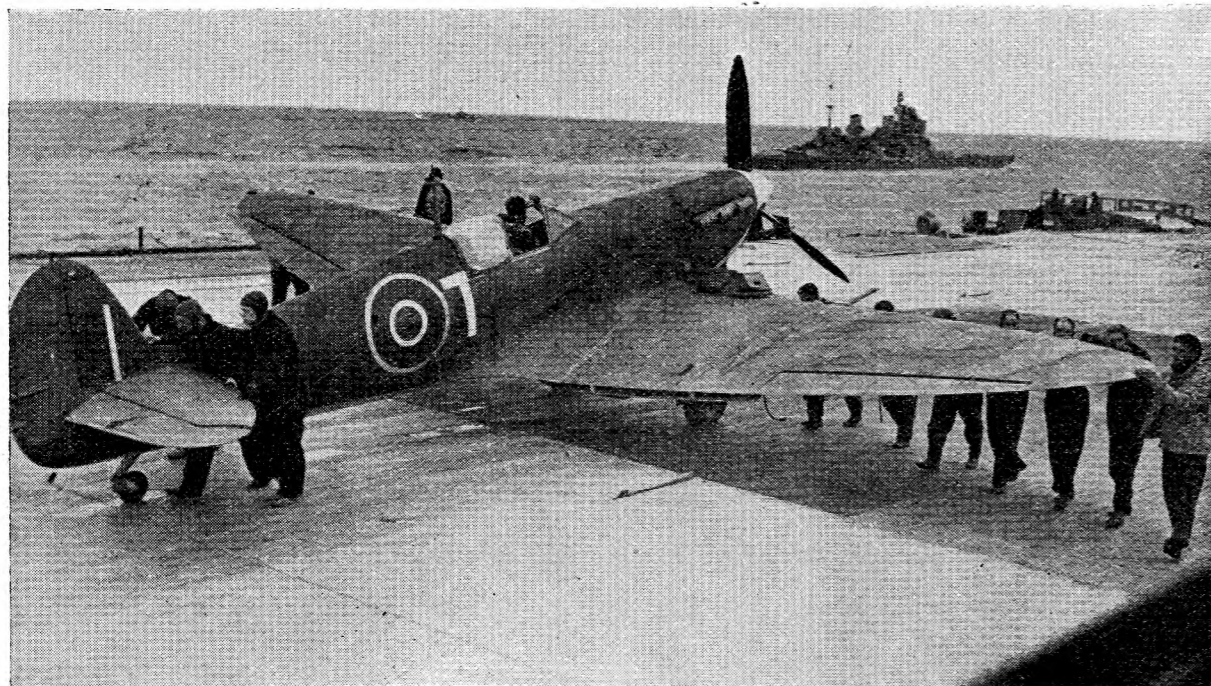

THE BARRACUDA'S FORBEARS

by James Hay Stevens

THE Barracuda, which was unveiled after the great "strike" on the *Tirpitz* on April 3rd this year, is the culmination of some 25 years' experience in the design of naval aircraft, the Fairey Aviation Company having specialised in aeroplanes for the Royal Navy since the middle of the last war.

In 1916 Mr. Richard Fairey (who had been designing since 1910, when he was connected with the Dunne inherently stable tailless aeroplanes) developed the original Sopwith Schneider seaplane into a single-seater U-boat hunter known as the "Hamble Baby." This little biplane was remarkable for one feature: it was fitted with flaps, though they were not known as such. These early flaps, called the "variable camber wing," were of the plain type—which does in fact have much the same effect as altering the camber. For many years Fairey aeroplanes alone in the world were always fitted with these flaps. It is curious to recall that in the nineteen-twenties many pilots were afraid of the new-fangled gadget and would not

make use of their flaps. Another early feature of Fairey aeroplanes common to all those illustrated in this article was folding wings.

Also in 1916 a two-seater reconnaissance biplane was designed for the old seaplane carrier H.M.S. *Campania*. This floatplane had to fit into a limited hold space, and therefore had folding wings. A number of variants were built—some with Rolls-Royce engines and some with Sunbeams, of varying power between 190 h.p. and 260 h.p. The majority had unequal-span wings, but the one illustrated, the IIIC, and one other had similar upper and lower planes.

The Fairey III

The IIIC was the first important member of a line of reconnaissance biplanes—the IIID, IIIF, Gordon and Seal—that were in service with the Royal Navy and the R.A.F. until the beginning of this war. All these aeroplanes were variants of the original design and were geometrically similar. The fuselage gradually became better

streamlined, but the wing plan remained the same throughout.

Although essentially a seaplane, the Fairey III could be fitted with a land undercarriage. The span was 46 ft. and the loaded weight 5,050 lb. The performance, with a 375-h.p. Rolls-Royce Eagle water-cooled engine, was good: maximum speed 111 m.p.h., landing speed 44 m.p.h., and climb to 5,000 ft. in 6.4 mins.

Stringbag

In the years between the wars Fairey's produced the Swordfish, a rather old-fashioned-looking biplane even for 1936, which was to prove the mainstay of the Fleet Air Arm's striking force for many years. With an all-metal fabric-covered structure the Swordfish is easy to build, so that it can be turned out rapidly in very large numbers. For this reason it is still in use as a torpedo trainer, and as a torpedo bomber from the small escort carriers, although many people thought it out of date at the beginning of the war. It is only necessary to recall Taranto to realise that the Swordfish is a fine aeroplane. The span of the

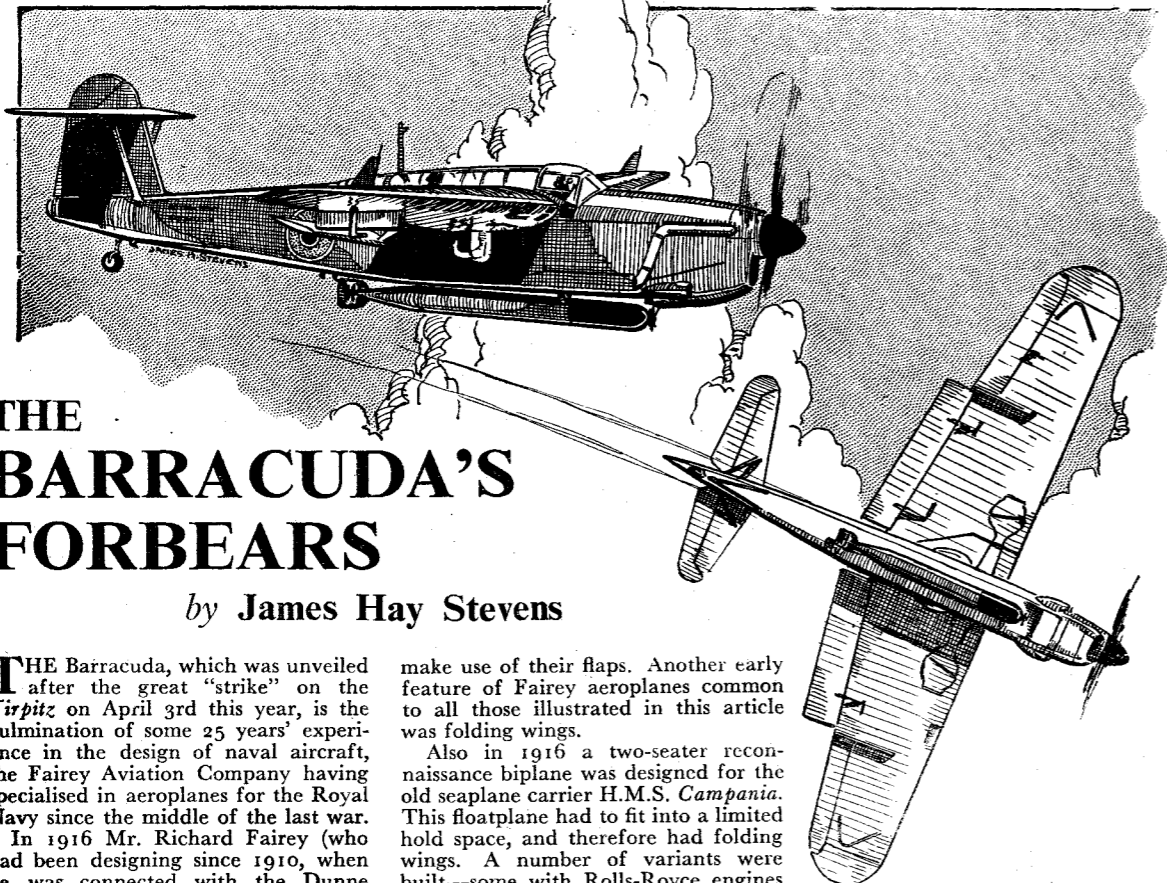

The Fairey IIIC of the last war. The short main floats wing-tips and tail floats were typical of the period.

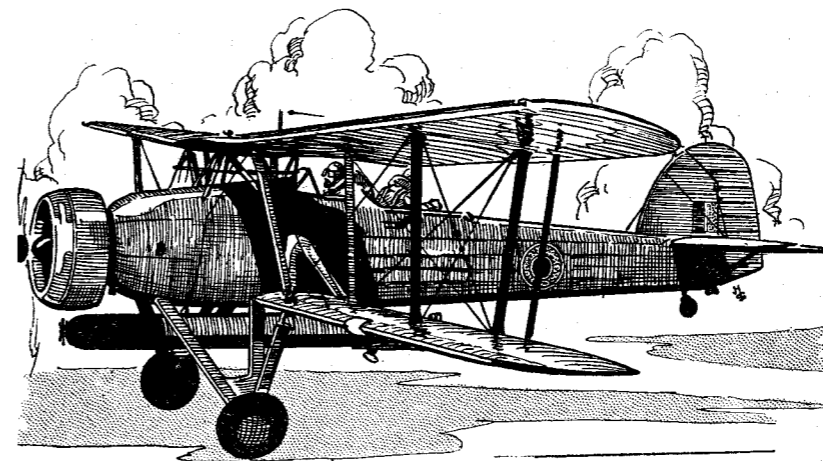
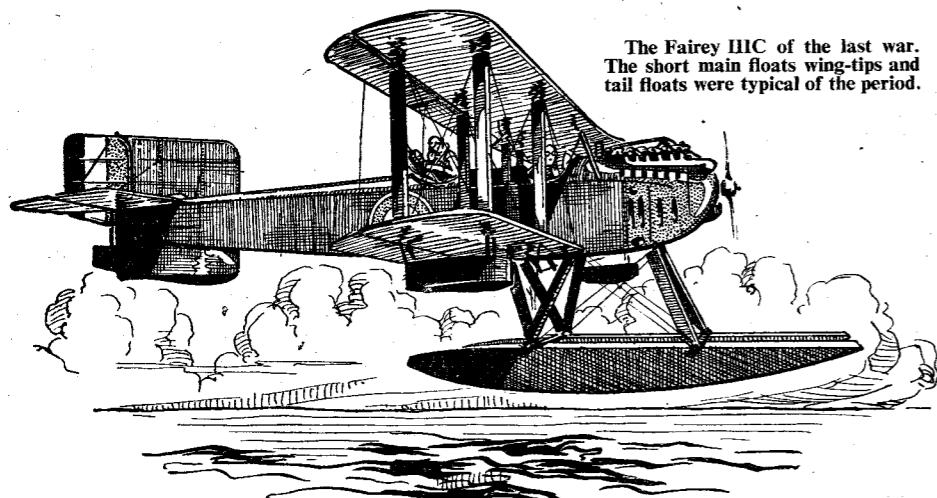

The Stringbag, probably the torpedo-bomber with the top score to date.

Swordfish is 45 ft. 6 in., the loaded weight being 7,720 lb. With a 690-h.p. Bristol Pegasus engine, it has a maximum speed of 154 m.p.h. and a landing-speed of 67 m.p.h.

Albacore

The Albacore appeared in 1939, and can be taken as the interim stage between the old biplane and the high-speed monoplane. The fuselage is of stressed-skin construction and the cockpits are enclosed, but the wings are still fabric-covered. The performance has not been disclosed, but the maximum speed with a 900-h.p. Bristol Taurus engine is probably close on 200 m.p.h. The span is 50 ft.

Although it has never been mentioned as taking part in a major action like Taranto, the Albacore was used with good effect for the bombing of dispersed German vehicles in the desert campaigns, and it is also mentioned from time to time as successfully attacking E-boats in the Channel.

Barracuda

At the time of writing only externally obvious features of the Barracuda can be commented upon.

When on the ground with the undercarriage down it is a very "bitty"-looking aeroplane; in fact, it seems to

be covered with as many excrescences as the Swordfish. However, once the wheels are up the lines improve, and the result is rather like the old Battle with a high wing and tailplane. The prime needs of naval torpedo aircraft are good view, low landing-speed and a high degree of manoeuvrability. From its appearance the Barracuda, like its predecessors, should have all three. The high wing with the long, glazed

The Albacore, an interim type between the old biplane and the high-performance monoplane

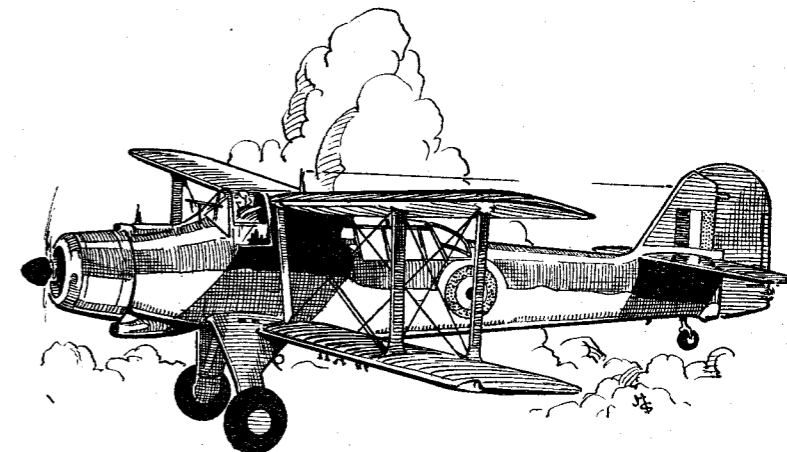

cockpit cover protruding above it and the observation windows in the fuselage sides under the wing ensure a good view for each member of the crew. The trailing flaps, which appear to be of the Youngman type, give the low landing-speed and also ensure manoeuvrability by reducing the wing loading. An unusual feature of such flaps is that by setting them to a negative angle of incidence they can be used as dive brakes.

The undercarriage of the Barracuda is an ingenious solution of the problem of retraction into a high wing. A triangular box girder is hinged to each side of the fuselage, and from the apices of the girders hang the oleo-legs and wheels. When lowered the units are braced to the top of the fuselage by knuckle-jointed struts and jacks. Upon retraction the jacks break the joints of these struts and pull the units up, so that the box girders lie flush in the sides of the fuselage and the wheels and legs lie in recesses in the wing.

The engine in the Barracuda is the Rolls-Royce Merlin 32, a special version for low-level operation. The engine is installed with a ducted chest radiator, rather like that in the nacelles of the Lancaster and York. The engine drives a Rotol four-bladed variable-pitch airscrew.

Dangerous Comment

A.T.C. Instruction No. 264 pays a nice compliment to the security-mindedness of A.T.C. cadets. It says: "The standard of security education in the A.T.C. is generally most satisfactory, and cases of indiscretion brought to notice are rare."

Going on to explain that you can't

be too careful about security, the Order explains why constant security lessons are necessary. In particular it draws attention to the fact that cadets employed in aircraft factories or in departments where work of a secret nature is carried out must be careful not to disclose details of their work, even to fellow cadets, who, though

they are in a specially favoured position with regard to some confidential details, are no more entitled than the rest of the public to learn of such secret work as does not concern them. The Corps on the whole has a very good record for discretion, and it is hoped that new members will maintain it.

AFTER successfully completing your I.T.W. course, there comes a day when—on arriving at Grading School—you are introduced to the aircraft in which most of your initial flying will be done. In my case it was a Tiger Moth, a type on which many thousands of other R.A.F. pilots were also initiated into the art of flying.

A Tiger is not very big (the span is only 29 ft. 4 in.), but when you first settle yourself into the rear cockpit, complete with flying kit and parachute, it seems an awful lot of aeroplane. The prospect that you will be allowed to take it up alone, inside a week or two—if you prove to be an apt pupil—is alternately terrifying and thrilling.

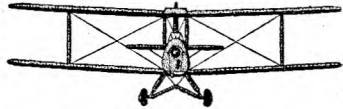

Cockpit Drill

As would be expected, a greater collection of instruments and levers is to be found inside the cockpit of a Tiger than, say, on the dashboard of a car. A haphazard check may quite likely prove disastrous if some important detail is overlooked. To avoid this, various "cockpit drills" have been evolved which have to be strictly adhered to from the start. In the Tiger the engine is first started and then the following check made, beginning at the port side of the cockpit and working right across to the starboard. After No. 2.)

1. Sufficient petrol in tank for flight.
2. All four switches "on."
3. Fuel cock fully "on."
4. Throttle friction nut loose for taxiing.
5. Mixture control set to "Rich."
6. Tail trimmer back for taxiing.
7. Note time on clock—correct—wind up clock.
8. Set altimeter to "zero feet."
9. See compass verge ring rotates freely; clamp on wind direction.
10. Oil pressure is 30/60 lbs./sq. in.
11. Unlock slots.
12. Doors and harness secure; ear-phones plugged in; goggles down.
13. Control surfaces move freely and in correct senses.

This list appears to be quite a handful when you first see it, but sitting in the cockpit and just checking from left to right quickly becomes second nature after the first few hours' instruction.

Whilst this check is being run through, the engine should be "revved" for four minutes at 800 r.p.m. (30 lb./sq. in. minimum oil pressure). Afterwards "rev" engine up to 1,500, checking the magnetoes by switching off each one in turn. The drop in r.p.m. should not exceed 50. Then full throttle for ten seconds (1,900-2,100 r.p.m.) at which the minimum oil pressure should be 45 lb./sq. in.

Vital Actions

Now at last comes the time to taxi

TIGER GEN

by W. A. Dean

out to the take-off point. The rudder is the main control surface used for taxiing, its effectiveness being increased by sudden bursts of throttle for turning purposes. The stick is held well back to keep the tail down on the ground. The forward view from a Tiger on the ground is very poor, so it is necessary to steer a zig-zag course in order to see if the path ahead is clear of aircraft and other obstacles. Many fatal accidents have happened whilst taxiing, so it is vital that due care be taken. The usual mistake made is to taxi much too fast, which is dangerous in any aircraft, but more so in the case of a Tiger, as no brakes are fitted.

On reaching the take-off point the aircraft is brought into such a position that only a 45-degree turn need be made to bring it into wind.

A last "vital action" check before taking off is then carried out as follows:

- T—Trimmer two-thirds forward; throttle friction nut tightened.
- M—Mixture control at rich (back).
- P—Pitch set to fine (not applicable to Tiger).
- F—Fuel cock fully on (forward); sufficient fuel for flight.
- F—Flaps lowered (not applicable to Tiger; substitute: Unlock slots).

This is best remembered by the first letters of each group—T, M, P, F, F. It will be seen that in the case of the Tiger "pitch" is not applicable and "slots" are substituted for "flaps." On more advanced types variable-pitch airscrews and flaps are fitted, and then this "vital action" really comes into its own.

The reason for "throttle friction nut tightened" in the above is to prevent the throttle vibrating shut on the climb or during normal flying. The result of the engine cutting just after taking off would mean a forced landing fight away, regardless of the unsuitability of the country below.

Due to the torque effect a Tiger will tend to swing round to the right during take-off at full throttle. This is corrected by applying sufficient left rudder as the throttle is opened. The fin is offset, so that no rudder is needed to keep straight when flying at the cruising speed of 94 m.p.h. (1,900 r.p.m.).

On the glide there is a tendency to swing round to the left, and therefore right rudder is needed in order to maintain a straight course.

A round figure for the most efficient climbing and gliding speeds is 65 m.p.h. Any deviation from this figure—high or low—will result in a reduced rate of climb in the former and a steep glide in the latter. The

r.p.m. when climbing should be 2,100.

The Tiger has had no bad vices, and is on the whole a very pleasant machine to fly. In the first stages most pupils tend both to over-control and over-correct. Actually, very little movement of the controls is needed for them to have the desired effect. Hold the stick lightly and make smooth movements—not rough, jerky ones. When the machine is temporarily disturbed from its flight path by air currents there is a natural tendency for it to return to normal again, due to its "inherent stability." In other words, it tends to fly itself.

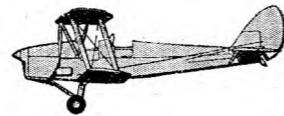

Landing

Two more "vital action" drills have to be carried out before and after landing:

Before landing—Tail trimmer correct for glide and slots unlocked.

After landing—Tail trimmer right back and throttle friction nut loose.

These drills both include references to the tail trimmer again. As this control is a great aid to the pilot and one which he is constantly using, here, briefly, is how it functions.

In a prolonged climb the constant back pressure needed on the stick becomes very tedious to the pilot. But by means of the tail trimmer this can be entirely cancelled out, so that no back pressure at all is needed on the stick. The operation of this control is perfectly simple. To relieve a back pressure on the stick the tail trimmer lever is moved *back* notch by notch until the correct position is reached. The reason for including the tail trimmer in all the drills is, in every case, to relieve pressure on the stick, thus leaving the pilot free to concentrate on other things.

The following points with regard to starting the engine will, if carried out, at least make you popular with the chap who swings your propeller for you:

First of all, see that the switches are off, the throttle closed and the petrol turned on.

Secondly, give your instructions clearly and loudly, taking no action until the message is repeated. You should also repeat all messages received, to show that you understand.

That just about completes all the more important Tiger "gen." Just one word of warning in conclusion. Different grading schools, as well as individual instructors, may use cockpit drills which are slightly different in minor details. The reason for giving the drills included in this article is just to give you an idea of what to expect in this line. May it prove of some use to you in taming the Tiger!

The A.T.C. is Empire Wide

WHEN the creation of the Air Training Corps was first announced by the Secretary of State for Air in January 1941 details of the scheme were sent to the Dominions overseas; and soon afterwards several Dominions governments had decided to form similar organisations under their own control. In some countries, notably New Zealand, Corps similar to the old A.D.C.C. already existed which could be used as the nucleus of a government organisation.

Now the A.T.C. of Britain has its counterpart in five Dominions—Canada, Australia, New Zealand, South Africa and Southern Rhodesia—and in India also. Newfoundland is at present considering a corps similar to that in Canada.

Here are a few facts about the A.T.C.s across the seas:

Canada. The Canadian Air Cadets formed by the Air Cadet League of Canada was taken over for direct administration by the R.C.A.F. in March 1942, and organised on the same lines as the A.T.C. A mission of R.C.A.F. officers came over in 1942 to study A.T.C. training and organisation. Present strength is about 20,000, with 230 squadrons.

Australia. In December 1941 Mr. Curtin, Prime Minister, announced that the Commonwealth Government would form an Air Training Corps under the R.A.A.F., with an immediate target of 84 squadrons, comprising 12,000 cadets.

There are now more than 13,000 cadets in 100 squadrons. More than 7,500 ex-cadets have now graduated to the R.A.A.F.

Roping up the Stringbag after the day's lessons.

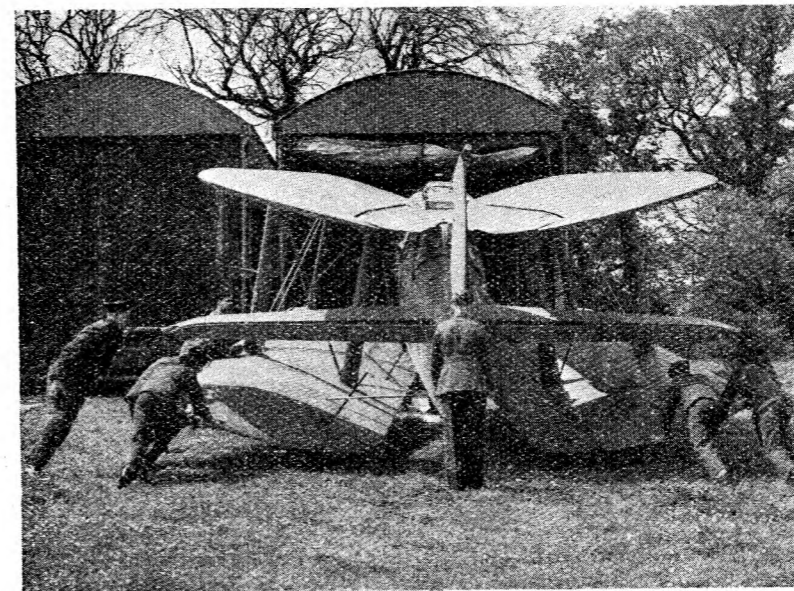

New Zealand. New Zealand's A.T.C. dates back to a scheme of part-time Air Force training inaugurated in 1939. In January 1941 there were 4,000 young men under instruction in the Dominion.

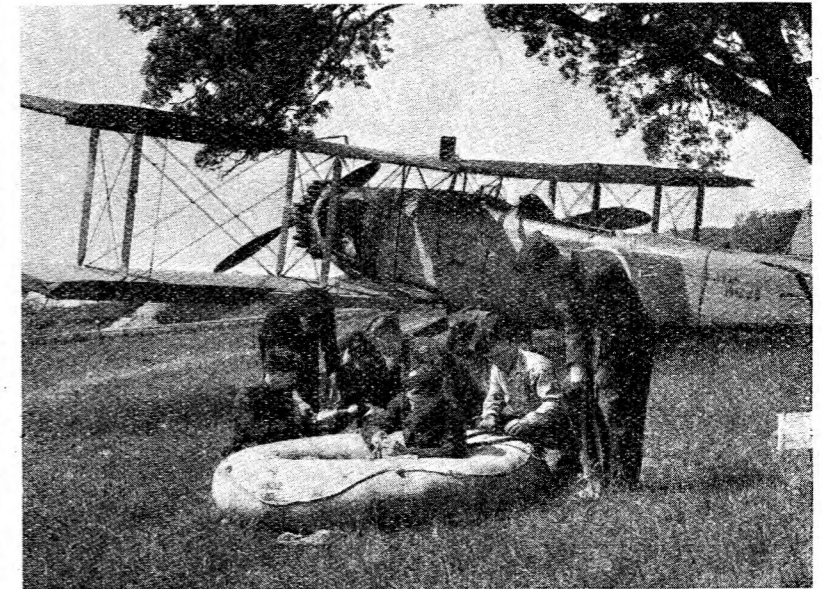

Naval ratings at a Fleet Air Arm Station instructing cadets with the aid of a dinghy and a Swordfish.

In March 1941 an Air Force Cadet Corps, similar to the A.T.C., was established. The A.T.C. now forms a separate command of the R.N.Z.A.F.,

under the jurisdiction of the Chief of the New Zealand Air Staff. It takes cadets for training up to the age of 20. Present strength is over 50 "town" squadrons and 60 school units.

South Africa. There is no separate Air Cadet Force in the Union. The counterpart of the A.T.C. is the Air Section of the Youth Training Brigade, which is controlled by the Army and gives full-time training for the services

to youths over 16. The Air Section is organised on the same general lines as the A.T.C., and a high proportion of the Y.T.B. goes to the Air Force.

University Air Squadrons have been formed at a number of universities in the Union.

Southern Rhodesia. At first an air section of the Southern Rhodesia Cadet Corps was set up in schools, with a syllabus based on that of Britain's A.T.C. Training includes camps and visits to Air Force aerodromes.

In May 1943 a separate Rhodesian A.T.C. was announced in the *Government Gazette*.

India. Air Training Corps have been formed at nine Indian universities, starting with Aligarh in December 1942. Others are at Allahabad, Punjab, Osmania and Madras (all formed in April 1942), Nagpur, Travancore and Calcutta (formed December 1943), and Bombay (formed June 1944).

ERRATUM

The picture on page 16 in the July issue was of the Wireless Operator's Panel, and not Flight Engineer's. Thanks to all the people who noticed this.

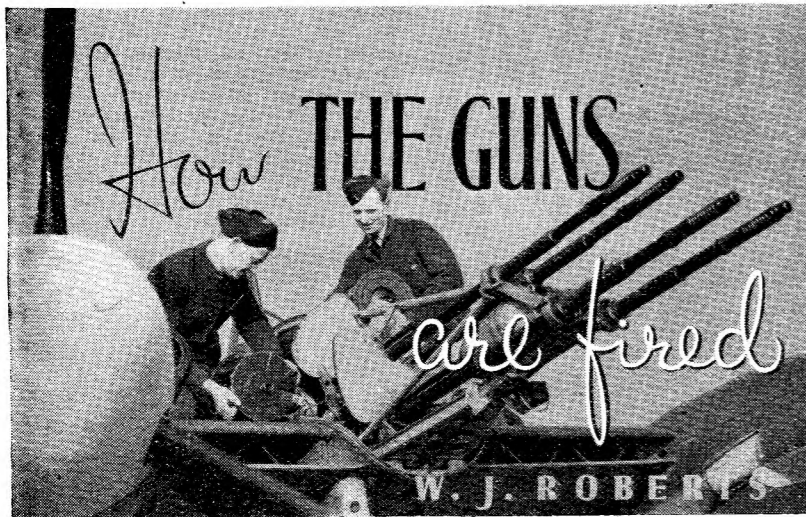

MODERN aircraft guns differ greatly from the primitive weapons used in early days. It is no longer possible to fire by using the trigger of the gun, as usually the guns are some way from the pilot or there are too many to be handled.

Consequently some form of firing control is used which enables the gun to be fired from a distance. Gun-firing systems are of three main types—mechanical, electrical or compressed air, each system being used according to its suitability for the type of gun and aircraft or the position of the guns.

The mechanical systems, in which the gun is fired by direct trigger or by flexible Bowden cable, are not often met with in modern practice.

Probably the most widely used system today is the electric control, with or without an interrupter gear. The theoretical circuit of such a system is given in Fig. 1, and a sketch of the operating mechanism is shown in Fig. 2.

From Fig. 1 it will be seen that pressure on the firing-button "A" permits current to flow from the batteries to the solenoid switch, which, when energised, closes the main circuit, allowing a heavier current to flow to the firing solenoids "B" situated on or

Fig. 1—Simple circuit of a two-gun electric gun-firing system with solenoid switch and firing solenoids.

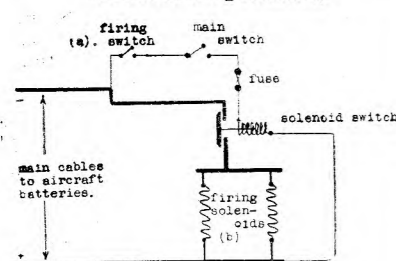

near the gun. These solenoids, when energised, exert a pull (or push) on the firing trigger of the gun itself.

The solenoids are shown in section in the second sketch, and consist of a coil of fine wire round a hollow core. When current flows the coil becomes a powerful magnet, and attracts the metal plunger, drawing it into the hollow core. The plunger, in turn, actuates the firing mechanism by

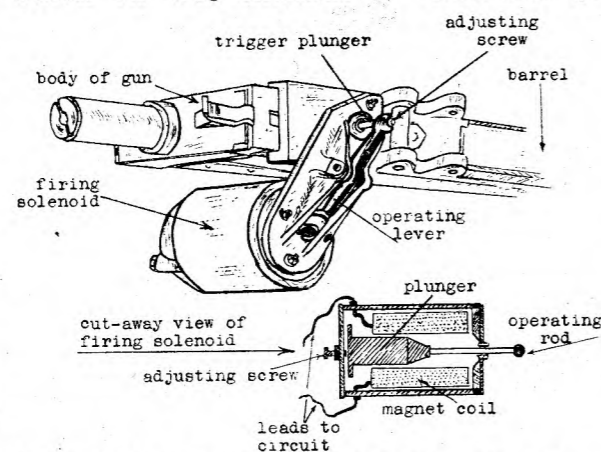

Fig. 2—Gun-firing solenoid attached to aircraft gun showing how the magnetic pull of the coil operates the gun trigger by pressure.

either direct pull or by a short Bowden cable.

Any number of guns may be wired to a common push button and fired simultaneously by this method. A typical example would be a single-engined fighter with two or four guns in each wing, the actuating solenoids being wired to a common main wire and all controlled by the single firing-button on the control column.

It is sometimes necessary to provide a safeguard to prevent the gunfire from damaging the aircraft itself; for instance, guns firing through the airscrew

circle or, as in the case of gun turrets, a gun may be brought into such a position that it might shoot the wing-tip, rudder or tailplane off its own machine. To prevent this possibility interrupter gear is used. The principle of all interrupter devices is similar: they either cut off the power or lock the trigger whilst the obstruction is in the line of fire.

When gun turrets have two or more guns the interrupter operates to stop each gun firing as it enters an obstructed section. Thus, if two guns close together are swung round to face the rear they may both be automatically cut off or, if they are wide apart, one may be cut off and the other continue to fire. A further point is that when a turret is left unoccupied and free to rotate, the power is automatically switched off and the guns rendered safe.

As an alternative to electric systems the air-line control is used on many up-to-date aircraft, such as the Spitfire (Marks I to V) and some of the Bristol types.

In these compressed air is supplied by a small compressor for brakes, flaps, etc., and a supply line is led to the firing-button. From the firing-button it goes by flexible tube and metallic pipes along the wing to the guns. At each gun there is fitted a small piston device which operates the trigger.

On the pressure of the firing-button air rushes along the lines and moves the piston of the firing unit, holding this in as long as the pressure is maintained on the firing-button. When the firing-button is released it opens a small vent hole, allowing the air in the lines to exhaust and releasing the pressure on the gun firing plunger, thus stopping the gun action.

No matter what the medium employed to transmit the impulse from firing-button to guns, there are certain safety precautions which are common to all systems. The firing-button is always provided with two positions—"fire" and "safe." In the latter position the button is either locked down or the electric power cut off. In addition to this, all electric systems are provided with a master-switch, and, in the case of turrets, the control may be switched through to the pilot in certain circumstances by means of a three-way switch.

The Gyroscope

by Ernest E. Trett, A.R.Ae.S.

THE gyroscope (Fig. 1) consists of a rotor mounted on ball bearings in a horizontal gimbal ring. The actions of this mechanism depend upon the dynamical properties of the rotor, which rotates at a very high speed.

The main properties are directional rigidity and precession. When the rotor is spinning it has a natural tendency to maintain a fixed axis of rotation, its spinning motion giving it the power to resist a force that tends to alter its direction of spin. When the force is sufficient to alter its axis of rotation the gyroscope will precess. Referring to Fig. 1, the weight (w) attached to the end of the axle of the rotor causes the rotor, and hence the gimbal rings (c) and (d), to turn round the vertical axis in the direction indicated at (B).

Many people find it difficult to see why a force acting at right angles to the axis of rotation should move to the side instead of down in the direction of the applied force. In this case it is

Fig. 1.—The Gyroscope.

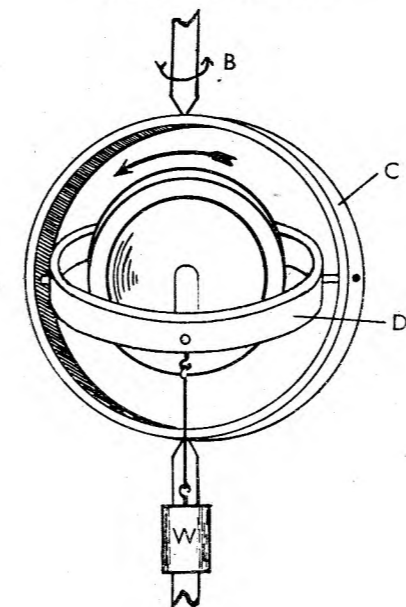

not the direction of the force that counts, but the plane of the applied torque.

An example of precession may be seen by the action of a spinning top, which is shown in Fig. 4. When spinning, the top moves round on its toe, forming a circle which gradually becomes smaller, i.e. the axis sway round the vertical, that is "precess."

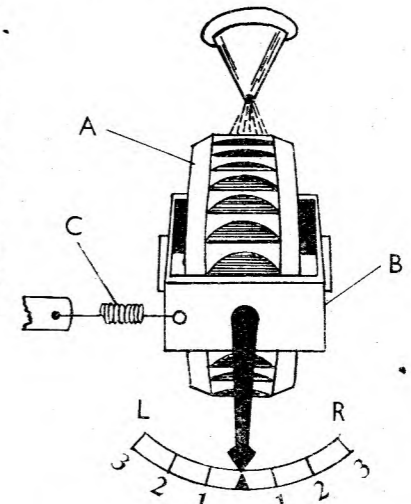

Fig. 2.—How the Turn Indicator works.

A similar principle may be observed when a weight is whirled round in a circle at the end of a line. It is acted on by a force which tends to create linear movements in a direction at right angles to the direction of the actual momentum. According to Newton's first law of motion, the weight has a tendency to fly off in a straight line, but at every point the line is always pulling it at right angles towards the centre of the circle, and this is known as "centripetal" force.

Fig. 3 shows the turning indicator, which represents a typical example of a gyroscopic instrument. It employs an air-driven rotor (A), which is mounted on ball-bearings in a horizontal gimbal ring (B). The axis of the

rotor is athwart the aircraft, and the axis of the gimbal ring fore and aft. The movement of the aircraft when turning corresponds to the rotation of the turning indicator in a horizontal plane, and a precessing torque is applied to the gimbal ring about the gimbal-ring axis which causes the gimbal ring, and hence the rotor, to topple.

A tension spring (c) which controls the movement of the gimbal ring will come to rest in a position of equilibrium when the precessing torque balances the tension of the spring. It will be seen that a turn of the aircraft to

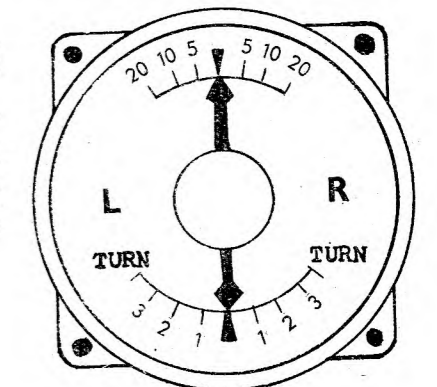

Fig. 3.—The Turn Indicator.

the left will cause the gyro to topple to the right; thus the pointer will move to the left and indicate the amount of turn, and vice versa.

It is the rate of turn which is indicated, i.e. the ratio of the amount of turn to the time taken for the turn. This is important, because the indication of a turn is given quickly at the commencement of the turn, and the pilot may act immediately. The amount of turn is indicated by the lower pointer (see Fig. 2) in relation to the zero position.

Flying straight with sideslip is indicated when the top pointer is displaced and the lower pointer remains central. An incorrectly banked turn is indicated by a displacement of both

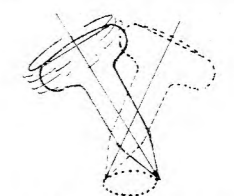

Fig. 4.—The Spinning Top.

pointers; a correctly banked turn results in a movement of the lower pointer only.

The turning indicator is usually included in a group of gyro instruments in the blind-flying panel.

Make your own Weather Forecast

by Flying Officer J. E. Dumbleton, No. 494 (Smethwick) Squadron

THE weather forecasts supplied to aircrews before all operational flights, are prepared after a careful study of the probable development and movement of depressions, anticyclones and fronts as revealed by a series of synoptic charts summarising weather conditions at regular intervals at a large number of observation stations dispersed over an area of many thousand square miles. The accuracy of the forecast of weather likely to be experienced during operations is dependent upon this system of widespread observations and upon the ability of the trained meteorological expert to make the correct deductions from the information shown on the charts.

Usually the forecast is remarkably accurate, and is intended to form a reliable basis for route-planning. But it has its limitations. An unpredicted variation in pressure-distribution may occur after the issue of the official forecast, resulting in quite different conditions of cloud and wind from those anticipated.

It is therefore of the greatest importance that all members of aircrew should become weather-conscious, and should be able to interpret correctly the significance not only of the weather forecasts and reports, but also (and probably more important) of their own observations. Proficiency in this can be attained only by continual practice. Every opportunity should be taken to make short-period forecasts and to anticipate weather conditions likely to prevail during a flight of, say, 100 to 200 miles from base.

The individual observer, lacking the records from which to make a synoptic chart, must rely upon his own observations to build up a picture of prevailing conditions sufficiently accurate and detailed to give a reliable idea of the probable weather some hours ahead or over districts some hundreds of miles distant. He must, therefore, keep his own records, and for a reasonable prospect of success details are required of cloud, wind, barometric pressure, temperature and visibility at regular intervals.

Clouds

Clouds alone afford quite the most reliable visual indication of forthcoming weather, and the deductions which can be made from cloud observations were described in the February issue of the *Gazette*. Briefly, high and medium detached cloud of cirrus, cumulus and associated types denote fine weather, and, if accompanied by a steady pressure above 30.25 inches (1,024 mbs.), are a good indication of

an extensive anticyclonic system and fine weather over a large area.

Cirrus-stratus is suspect, and if followed by alto-stratus and a fall in pressure continuing below 29.5 inches (1,000 mbs.) will very likely be followed by nimbo-stratus with rain, poor visibility and generally bad flying weather.

Stratus cloud usually denotes calm, dull conditions, but has no special weather significance. Cumulo-nimbus is sufficiently threatening in appearance to give sure warning of the approach of storms with thunder and rough weather.

Wind

Wind direction and strength is an accurate guide to the character of pressure distribution. At 1,500 ft. to 2,000 ft. the wind direction closely follows the isobars, and its velocity is in direct proportion to the distance between them.

Two points are to be remembered in connection with wind direction. First, to an observer in the Northern Hemisphere, standing back to wind, the pressure is always lower on the left than on the right, and secondly, wind blows clockwise round an area of low pressure and counter-clockwise round an area of high pressure. Thus wind direction gives the observer a "fix" in relation to the local pressure distribution.

For recording wind strength the individual observer cannot do better than follow the Beaufort scale, but using only the following four main divisions:

- Calm—Beaufort scale Nos. 0 and 1:
Wind vanes are not moved.
- Light breeze—Beaufort scale Nos. 2, 3, 4: Light flags are moved.
- Strong wind—Beaufort scale Nos. 5, 6, 7: Tree branches are moved.
- Gale—Beaufort scale No. 8 and over: Structural damage occurs.

Pressure

Frequent observations of atmospheric pressure, as indicated by the barometer, are essential, since changing pressure is a feature of all weather changes. A fall in pressure always precedes a deterioration in the weather, and a rise precedes an improvement, but this must not be taken to mean that rain invariably follows a fall or that fine weather necessarily follows a rise. Due regard must be given to the relative pressure at the time, whether high or low, to the rate of change and to the remaining observations which are made.

Temperature

Records of temperature are valuable in assessing the significance of variations in pressure, and give an indication of the likelihood of fog and mist. The passing of a "front" is usually accompanied by temperature changes.

Observations of "dry" and "wet bulb" temperatures and the determination of relative humidity therefrom are of great value in giving a measure of the amount of moisture in the air, and therefore of the probability of precipitation, which can always be expected when the relative humidity is over 85 per cent, although not necessarily in the form of rain.

Visibility

Conditions of visibility give a dependable indication of atmospheric conditions, and although variable with the season and locality, good visibility usually accompanies a rising barometer and is an indication of improving weather. Reduced visibility is frequently found with a falling barometer preceding a period of bad weather.

Town-dwellers may find difficulty in determining true visibility both on account of restricted horizon and of dust and smoke particles present in the air, which may reduce visibility without any weather significance.

For recording visibility a shortened version of the usual scale may be used by the individual observer, using only:

- Under $\frac{1}{4}$ mile—Fog.
- $\frac{1}{4}$ mile to 1 mile—Poor visibility.
- 1 mile to 4 miles—Moderate visibility.
- 4 miles to 8 miles—Good visibility.
- Over 8 miles—Very good visibility.

Systematic records of these five observations taken at frequent intervals will give the required information to build up a picture of prevailing conditions, and from a comparison of successive records a forecast may be made, the official forecast may be checked, or weather many miles away may be estimated.

It is essential to keep clearly in mind that the object of the records is to ascertain what changes are occurring. A series of observations showing no change is a clear indication of the continuation of prevailing conditions, but any appreciable or sudden variation shown by the records is a warning that a change in weather is probable.

The significance of the changes that do occur can be fully appreciated only after considerable experience, since an unending variety of weather may be accompanied by or result from the various combinations of conditions.

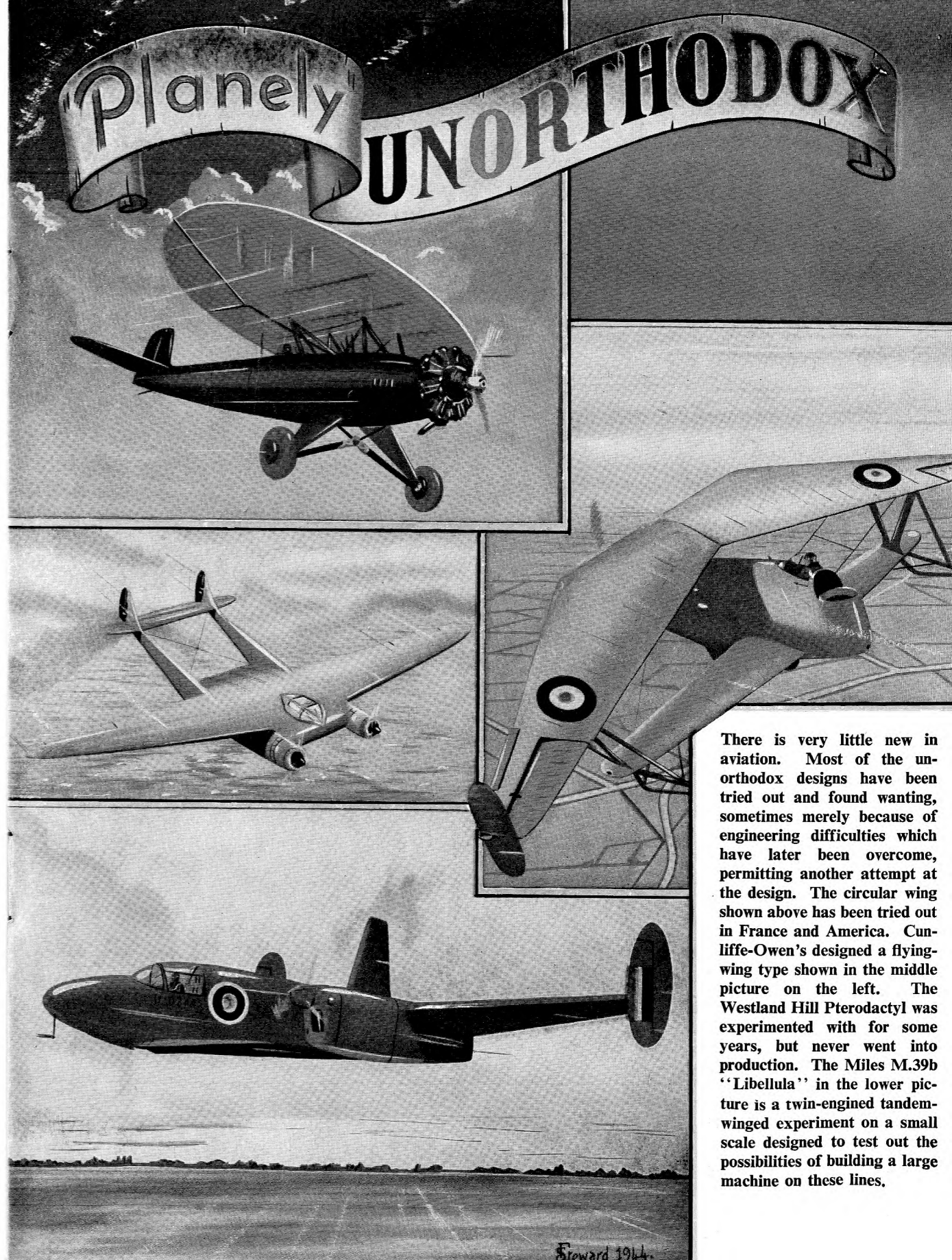

There is very little new in aviation. Most of the unorthodox designs have been tried out and found wanting, sometimes merely because of engineering difficulties which have later been overcome, permitting another attempt at the design. The circular wing shown above has been tried out in France and America. Cunliffe-Owen's designed a flying-wing type shown in the middle picture on the left. The Westland Hill Pterodactyl was experimented with for some years, but never went into production. The Miles M.39b "Libellula" in the lower picture is a twin-engine tandem-winged experiment on a small scale designed to test out the possibilities of building a large machine on these lines.

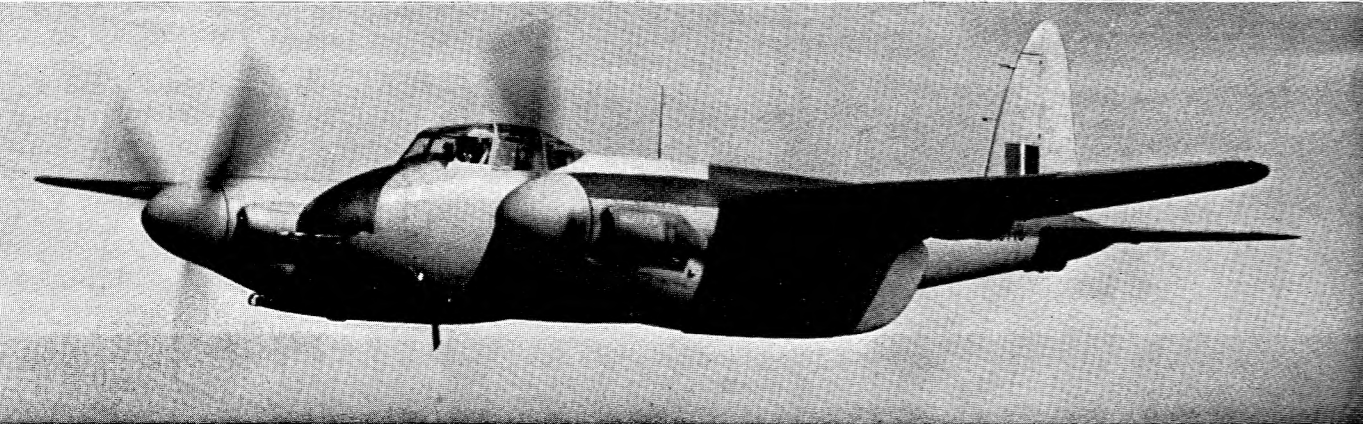
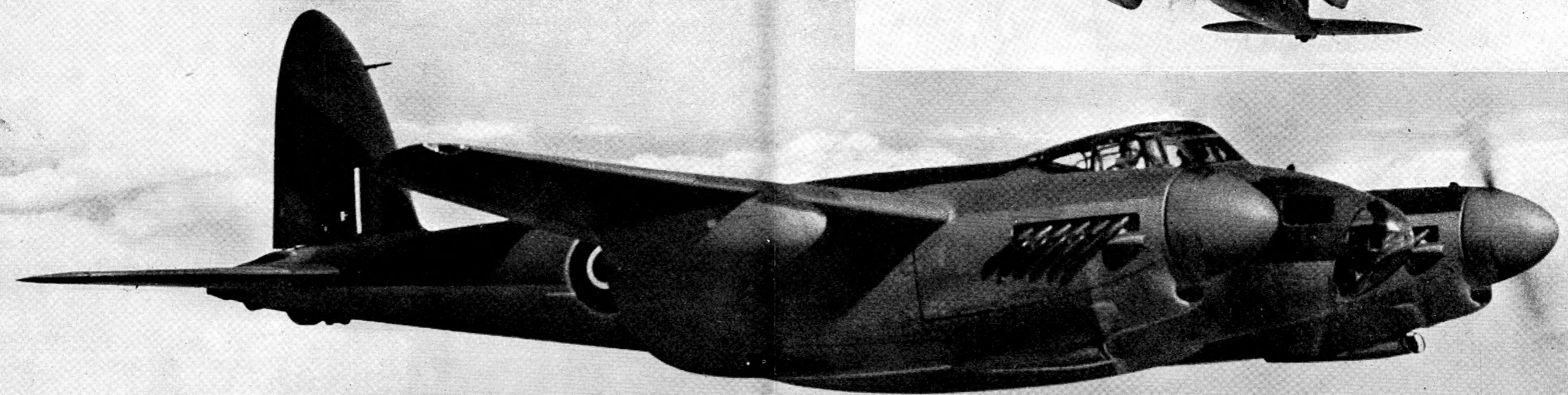
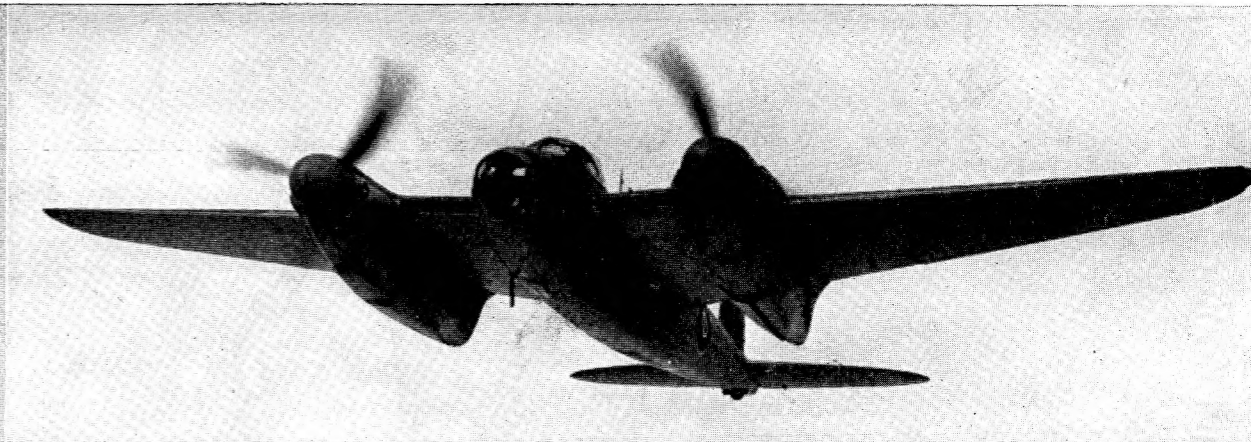

The Mosquito

In Lines COMPARED



h.p. at 24,000 ft., and weighs 1,640 lb. This works out at about 1.3 lb. per h.p.

The figures quoted above are not necessarily the highest power which the engine is capable of developing, but are the rated powers and, in the case of the latter two engines mentioned, the rated powers in the high supercharger gear. The engines are capable of developing more power for short periods, and this would, of course, improve the power/weight ratios already quoted. Above rated altitude the power output begins to fall.

Although the increase in power between the two-speed supercharger engine and the two-speed, two-stage engine does not appear to justify the considerable increase in weight, it should be remembered that 1,250 h.p. at 24,000 ft. is worth a great deal more to the aircraft than 1,250 h.p. at 17,500 ft.

The Mark number of the first engine to be produced in each of the three groups is as follows:

- Single-speed supercharger — Merlin II.
- Two-speed supercharger — Merlin XX.
- Two-speed, two-stage supercharger — Merlin 61.

Jig-Sawed

SEE PAGE 19

1, Short Stirling; 2, Martin Marauder; 3, Douglas Havoc; 4, Beechcraft AT-IIIs; 5, Fairey Fulmar; 6, Vought-Sikorsky Chesapeake; 7, Vultee Valiants; 8, Grumman Wildcat; 9, Blackburn Botha; 10, Miles M.28, Miles M.18; 11, PE.2; 12, Martin Baltimore; 13, IL-2 Stormovic; 14, Douglas Dauntless; 15, Grumman Hellcats; 16, Grumman Avengers; 17, "Doodle-Bug" (Kivik); 18, Hawker Typhoon; 19, Fairey Barracuda; 20, Short Sunderland; 21, De Havilland Mosquito; 22, General Aircraft Hotspurs; 23, Airspeed Horsas and Armstrong-Whitworth Whitleys; 24, Junkers Ju 52; 25, Dakota C-47 Dakota; 26, Republic Thunderbolts; 27, Martin Baltimore; 28, Handley Page Halifax; 29, De Havilland Flamingos.

(In last month's "For You to Name" No. 16 should have read Vickers-Armstrongs Warwick, not Armstrong-Whitworth.)

Odds and Ends

SEE PAGE 21

1, Martin Marauder; 2, Heinkel 111K; 3, Junkers Ju 90s; 4, Douglas Dauntless; 5, North American Mitchell; 6, Bristol Beaufighter; 7, Boeing Fortress II; 8, Avro Lancaster; 9, Curtiss Seamew; 10, Curtiss Helldiver; 11, Republic Thunderbolt; 12, Vultee Vengeance; 13, North American Mustang; 14, Republic Thunderbolt; 15, Junkers Ju 52; 16, Junkers Ju 87; 17, North American Mitchell; 18, Martin Marauder.

NOTED in the King Arthur legends as an enchanter, Merlin has given his name and powers to an aero-engine which for several years has been casting a spell over the Luftwaffe.

Designed and constructed by Rolls-Royce as long ago as 1936, the Merlin is based very largely upon the Rolls-Royce "R" engine which powered the S.6.B seaplane when it established a record speed of 407.5 m.p.h. in 1931. The "R" engine was slightly bigger than the Merlin, and developed 2,600 h.p. in its most advanced state of development when it broke the record. For racing in the Schneider Trophy contest its power was lower, but its life was longer. But in neither form was it anything more than a sprint engine, and as such it would have been unsuitable for normal use.

The Merlin layout is similar to the Rolls-Royce "R." It is an upright-vee 12 engine, with a supercharger mounted at the rear end of the crankcase, and drives a propeller through a reduction gear at rather less than half crankshaft speed. Through this arrangement the centre line of the propeller shaft is well above the centre line of the crankshaft, with the result that it allows a reasonably low installation of the engine in the airframe, without increasing the height of the undercarriage, to give ground clearance for the propeller in a single-engined aircraft.

Try-Out

The first aircraft to be delivered to the R.A.F. in quantity, powered by the Merlin, was the Fairey Battle. This was a high-speed bomber, although its top speed of 250 m.p.h. would look rather silly today. It did, however, fill a gap in our tactical forces, and is now of course replaced by aircraft such as Mosquitoes, Bostons, Hurricane bombers, etc., whose top speeds are all very much higher.

Fighters

The Hurricane and the Spitfire were the next Merlin-engined aircraft to join the R.A.F., the Hurricane being ready a little time before the more delicate Spitfire. By the outbreak of war there were several squadrons of these aircraft in service to supplement the old-fashioned but nevertheless efficient Gladiator biplanes.

The building of these two fighters both to the same specification around the Merlin was a happy occurrence for this country. The Merlin was undoubtedly one of the main factors in the Battle of Britain victory, and with the exception of the Peregrine engine (a smaller Rolls-Royce product) in the Whirlwind, the Merlin dominated the sky.

Bombers

Although fighter aircraft were given priority in those days, two bombers—the Wellington and Whitley—both had versions with Merlin engines in place of the Pegasus and Tiger engines, respectively, in the original marks of these bombers. When this first climax of the air war had passed, Merlin engines were used in both the Lancaster and Halifax, and today it is probably the most-used engine in the world. So successful has it been that it is being manufactured by Packards in America. The American Merlin is being fitted to Canadian-built Mosquitoes, and to the Mustang fighter, which has consequently risen from being a good aircraft with its original engine to amongst the best fighter aircraft in service today.

The shape of the Merlin allows a very low-drag cowling to be constructed around it, and it is not easy to believe that the Mosquito has got as much as 2,500 h.p. available within its two engine cowlings.

There have been three separate and distinct versions of the Merlin engine and many other variants within each of the three groups.

Supercharging

The original Merlin was provided with a single-speed supercharger, and developed about 1,000 h.p. at 12,250 ft. With a weight of 1,375 lb., this gave about 1.4 lb. per h.p.

The next development was the two-speed supercharger version; the higher speed at which the impeller could be driven allowed the power to be maintained up to a greater height. This engine developed about 1,175 h.p. at 17,500 ft., and weighed 1,430 lb. This is equivalent to about 1.2 lb. per h.p.

The third stage, but not necessarily the final one, provided the basic engine with a two-speed, two-stage supercharger to give higher boosts at higher altitudes. In fact, it produces 1,250

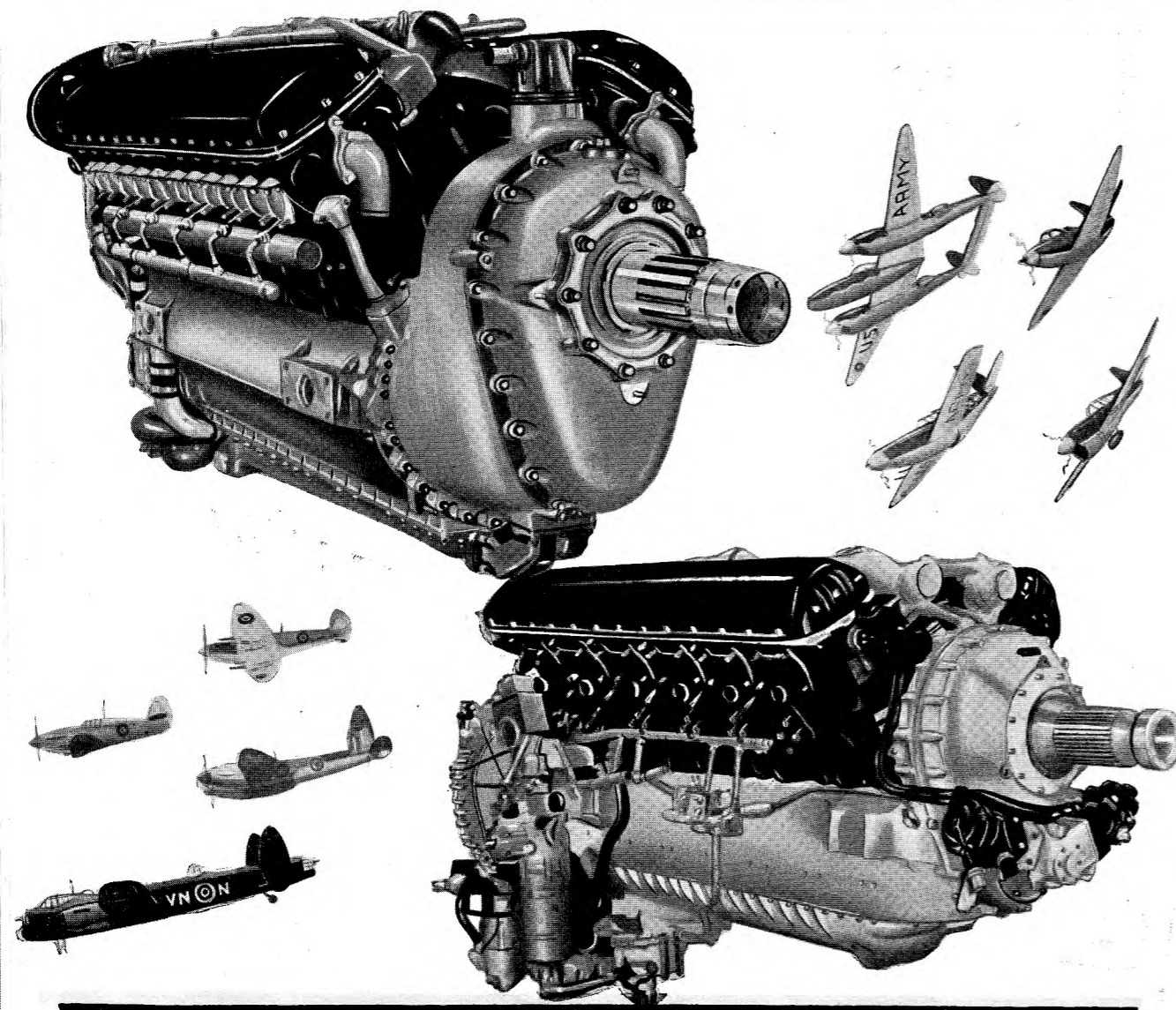

Top picture Allison V-1710.

Designed by Mr. R. M. Hazen of General Motors Corporation nearly ten years ago, the 12-cylinder V-1710 (so designated from its cylinder capacity) powers a number of U.S. aircraft such as the Airacobra, Kittyhawk, Lightning and Mustang 1. There are three variations of the V-1710—the C15 (Lightning), E4 (Airacobra), and F3R (Mustang 1), but they differ only in minor details, the heaviest, the F3R weighing 1,340 lbs.

Some technical details.

No.	Take-off B.H.P.	Rating
E 4	1050	1000 at 10,800 ft.
C15	1040	1090 at 13,200 ft.
F3R	1050	1150 at 12,000 ft.

Cylinder dimensions 5. 5. 6 inches stroke
Capacity 1710 cu. in. (28.1 litres).

Bottom picture Rolls Royce Merlin engine, described in an article on page 17.

FOLLOW YOUR LEADER

CONTINUED FROM PAGE 5

Restraint

There is, on this account, much to be said against all-ranks dances. It is no bad thing to mix ranks, because when the right men mix they remain, in mind and outlook, officers, non-commissioned officers and men. But to look upon one inglorious hotch-potch of all ranks competing at the bar for the favours of local ladies is not a cheerful spectacle.

The fault can only lie with the officers. You never find a man or a sergeant making a pass at an officer's partner. I am afraid you do sometimes see the reverse, generally amongst officers who were quite recently N.C.O.s. They cannot get it into their heads that if they are going to accept

salutes in the street, front seats at regimental shows, and all kinds of privileges in travel, they must sacrifice the other liberties they were allowed before. The officer should not sink to the level of a canteen party. He should keep his own level; then, in his presence, the men will keep it with him.

No Talking Down

Similarly, an officer who in lecturing never uses a word they do not completely understand has practically let them down.

Remember your choice of books when a boy. You probably hated the books designed for you, and chose those it was thought you would never understand. Nor was this stubbornness or conceit. They were better books, and you knew it. How many will admit, even now, that for years they used to

come across the same word in print, and would consistently mispronounce it, yet know it as an old friend because of the sense in which it appeared. If the author had written down to our level we should never have known the word. Instead, we liked him for using it. The word I remember most clearly was "mizzled," which I pronounced "mizzled"; and I thought it meant "muddled." So it did!

Therefore, if you ask how to become a good officer, I would say, model yourself on one who is. If you ask how to choose one, I will say, look for Personality, Sympathy, Initiative, Knowledge and Discipline, in that order.

If you have these qualities, or if your son has, there is no need to have been born a leader. The rest have all been born to follow.

SOONER or later everyone who flies is going to find the need of guts. That first fine thought of driving an aeroplane and feeling a bit of a hero is going to be tempered by a new sensation—the sensation of fear. It may come as early as the first solo, or even when the instructor demonstrates a spin for the first time. At this stage it doesn't matter much how one reacts. The instructor is in charge of the aircraft, and that is a very comforting feeling. It will probably be more serious, need a little more overcoming, when one is sent up to practise rolls and spins or some of the less pleasant types of aerobatics. It quickly wears off, because aerobatics are easy, and one soon acquires confidence in one's ability. It will occur again throughout one's flying career—when one takes up a new type for the first time, the first flight in a Seafire or a Hellcat or a Barracuda, and the first deck landing. But these moments are no more than mildly disturbing; you are keyed up and probably on the top of your form. What if the palms of your hands are a bit moist? There's little in it, and unless you happen to be one of the unlucky ones who will never make a first-line pilot, you will agree that "guts" haven't yet been called in.

It is on the operational trip, the long sea-crossing with an attack to be made at the end of it, when greater qualities are demanded. It is the night landing in rough weather after a sortie, the moment when your aircraft is separated from the rest of the squadron, when you are lost, when the job has to be done over again—and then again. The weeks and months of operations, when the strain mounts and is bringing out every ounce of stamina you possess. That is when you need guts.

And how are guts acquired? Of course, I don't know—and I don't think anybody knows. We have recognised in this war that many fine fellows have a breaking-point, and that after

GUTS

by 'Stringbag'

a while they must be given a rest, whether they like it or not. It is a matter of health, and not of courage. After a rest they are as good as ever again.

Imagination plays its part—the bigger the imagination the greater the strain and the higher the quality of guts required to carry on. A brave act for one man would not always be a brave act for another.

Keep Fit

But there are certain things a man can do to remain at the top of his fighting form. They are partly physical things and partly mental. Maybe the physical side is the more important, for flying is a sedentary job, and it is easy enough to get into bad condition, particularly on a ship. If you can say that at any given moment you can cover 100 yards in equal time to your best before the war, then there is not much wrong with your health. I have known pilots who have taken a tremendous amount of exercise, and grown to love taking it. Among the things done in a casual way by friends during this war have been to climb a 20,000-ft. mountain, walk 20 miles on a day off, and swim on every possible occasion. Pretty dull, and pretty ordinary things to do, but done with an enthusiasm which made a pleasure of them.

Mentally at Peace

On the mental side it is more difficult to speak. But if you have seen a wing-threequarter going flat out as

he reaches the opposing full-back, and beating him through sheer determination, you will understand its significance. From one's own personal point of view it is something of a triumph to know that you have pue in the extra ounce of determination which has got you through, and you will find that on the next occasion it will be easier for you to bring it off again. Apply that to flying, to the moment when the extra spurt is needed, and ever afterwards it will seem less difficult.

So perhaps one can say that the man who is physically fit and who is mentally at peace with himself probably has a reserve of guts which is greater than the next man's. It means living to the full, with very little spare time, not only working hard, but, equally important, playing to the very limit of one's physical capacity.

Not long ago I was discussing this question with a senior officer who went through most of the Malta convoys. Day after day he saw his squadron go up and fight, shooting down and being shot down, day after day, in some of the fiercest battles of the war. This is what he said:

"The chap who shows the most guts in a tight corner is usually the little insignificant fellow, the quiet chap whom you never suspected. He doesn't shoot a line, his conversation often seems pretty dull . . . he's an ordinary chap, very ordinary." Then he went on: "I've met a lot of tough guys, big fellows with big voices whom by every standard you might consider hard cases; but it doesn't mean a thing—they may let you down quicker than the insignificant chap you've never thought about."

Then he went on to praise the loyalty as well as the courage of the type of man one so often found in peace-time in rather a second-rate job.

That, I think, may be an encouragement to those of us who don't look like lions or sound like tigers.

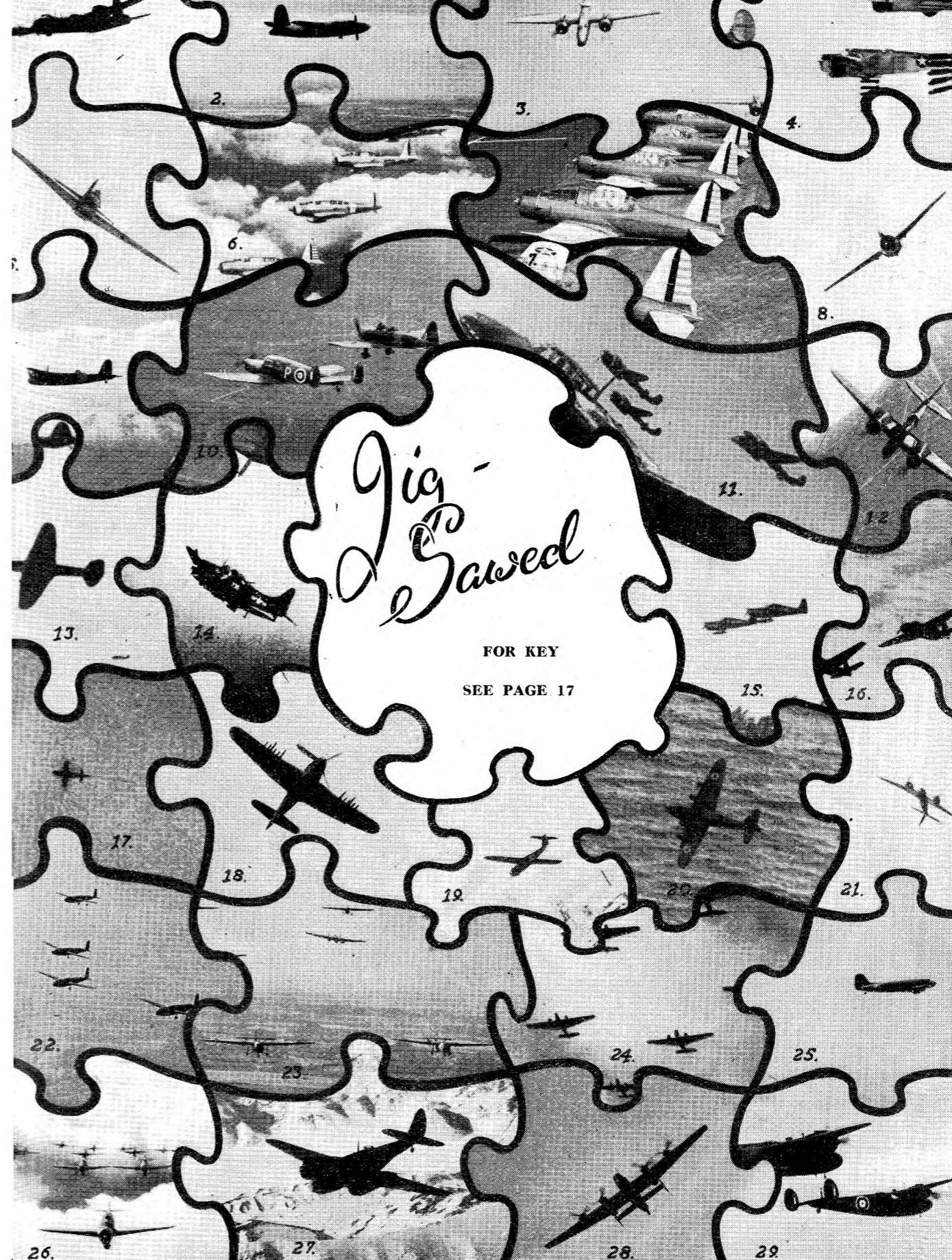

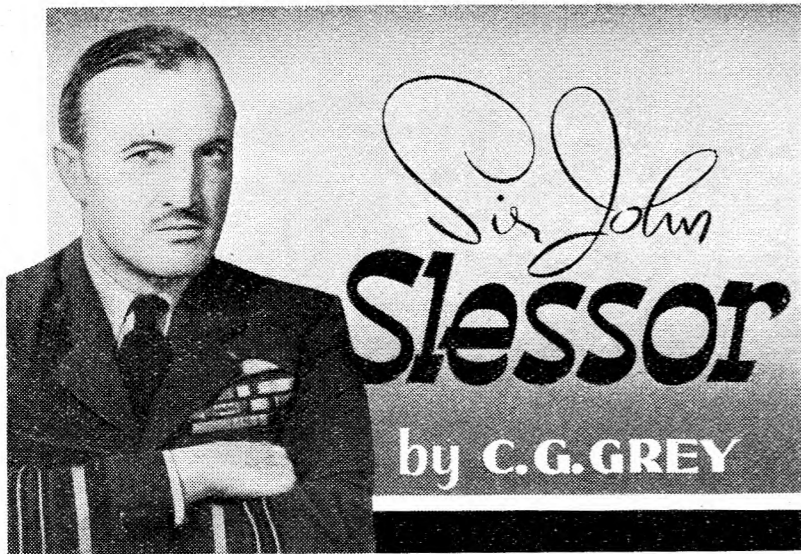

AIR MARSHAL Sir John Slessor, K.C.B., D.S.O., M.C., is, so far as I can discover, the only officer of his rank in the R.A.F. who has never been in the other Services. All the others were in the Navy or the Army before joining the R.N.A.S. or the R.F.C. before or during the war of 1914-18.

John Cotesworth Slessor was born at Rhaniket in India on June 3rd, 1897, so he is only 46, which is young for his rank. He was educated at Haileybury—which has given us Sir Trafford Leigh-Mallory, A.O.C.-in-C. Invasion Air Forces, among many other distinguished officers—and he was only a few weeks over 17 years of age when war broke out on August 4th, 1914. But as soon as he reached military age he joined up, and was appointed 2nd lieutenant (on probation) in the Royal Flying Corps, Special Reserve, on July 6th, 1915, four weeks and a few days after his eighteenth birthday. Actually, he was "posted" to Brooklands, then an elementary flying training school, on June 16th, a fortnight after his birthday.

After four weeks at Brooklands and a month at Gosport (then an E.F.T.S.), young Jack Slessor was appointed a flying officer and posted to No. 23 Squadron, R.F.C., but was soon transferred to No. 17 Squadron, Middle East—an experience which must be useful to him now. There he was wounded and invalided to Home Establishment—he has had a limp from that wound ever since. He was awarded the Military Cross, which was gazetted on January 1st, 1917. Also, he was mentioned in despatches in October 1916 for his work in the Sudan. He soon became fit again, for in December 1916, being then 19½ years of age, he was commanding a flight in No. 4 Reserve Squadron as a temporary cap-

tain. In February 1917 he was in No. 58 Reserve Squadron.

By May 1917 he was in France, commanding a flight in No. 5 Squadron, with the British Expeditionary Force. For his services he was made a Chevalier (Knight) of the Order of Leopold of Belgium—gazetted September 24th, 1917—and in March 1918 he was awarded the Belgian Croix de Guerre.

In July 1918 he went to the Central Flying School at Upavon on promotion to temporary major; the C.F.S. had by then become an establishment where instructors were taught how to instruct. A month later he went on a course to the School of Special Flying, which had been set up by Lieut.-Colonel Robert Smith-Barry, D.S.O., at Gosport. Its mission in life was to teach pilots who thought that they could instruct that they did not even know how to fly.

Today the whole system of flying training in this and in most other countries is based on a combination of the C.F.S. and Gosport principles. Instructors' "patter" today is the old C.F.S. patter brought up to date from time to time. The Gosport flying was all the more astonishing, because its inventor and leading performer, Robert Smith-Barry, was permanently lame because of a crash in 1914, a week or so after the start of the war. And he is still flying.

In 1923 he did a course at the R.A.F. Staff College. And then he took command of No. 4 Army Co-operation Squadron on promotion to squadron leader in April 1925. He did more than three years in that job, until in October 1928 he came back to the Directorate of Operations and Intelligence at the Air Ministry. Then he was at the R.A.F. Depot for five months before going to the School of Army Co-operation at Old Sarum, to

rewrite the Manual of Army Co-operation, one of the most important things he has done. He had already shown his ability to write by winning the Gordon Shephard Memorial Prize Essay for 1923.

Keeping to his Army Co-operation, Squadron Leader Slessor went on a course of a year to the Army Staff College at Camberley in January 1931, and stayed on there as an instructor on promotion to wing commander for three years. After which—typical of him—he went to the C.F.S. for a refresher course in flying.

After all that he went, in February 1935 to command No. 3 (Indian) Wing, and was in India for two years. While there the great earthquake happened at Quetta, where he commanded. He and his wife did splendid work during and after that upheaval, and won high official praise, besides winning the affection of R.A.F. troops and civilians and natives alike.

He came home in May 1937, after travelling at his own expense by way of Singapore, China, Japan and the U.S.A., and then went to the Air Ministry, to the Directorate of Intelligence as Deputy Director of Plans, and in December 1938, as a group captain, he became Director of Plans. He was promoted to air commodore in September 1939.

In October 1940 he was sent to the U.S.A. on a special mission. He had been there before, as shown above, and I will not offend his modesty by retailing the high opinions which certain of my friends in the States have expressed of his work there.

When he came back he was appointed in May 1941 as air vice-marshal (temporary) to be A.O.C. No. 5 Group. There he had the Manchesters and the very first of the Lancasters and the blockbusters. In April 1942 he was made Assistant Chief of the Air Staff in Charge of Policy.

In November of that year he was made A.O.C.-in-C., Coastal Command, with rank of air marshal (acting). While he was in command the R.A.F. definitely got the upper hand of the German submarine—and during the peak month of our ascendancy the aircraft of Coastal Command sank more than half the submarines destroyed.

Besides the honours and awards already recorded, Air Marshal Slessor was appointed Air Aide-de-Camp to the King on January 1st, 1939. He was made a Companion of the Bath on January 1st, 1942, and a Knight Commander of the Bath in June 1943.

In January 1944 he was appointed A.O.C.-in-C. Middle East, where his experience of Army Co-operation and of the Army, his previous service in that area, and his wide knowledge of the world will be of high value. If or when things blaze up in the Balkans, Air Marshal Slessor will be worth watching—and afterwards.

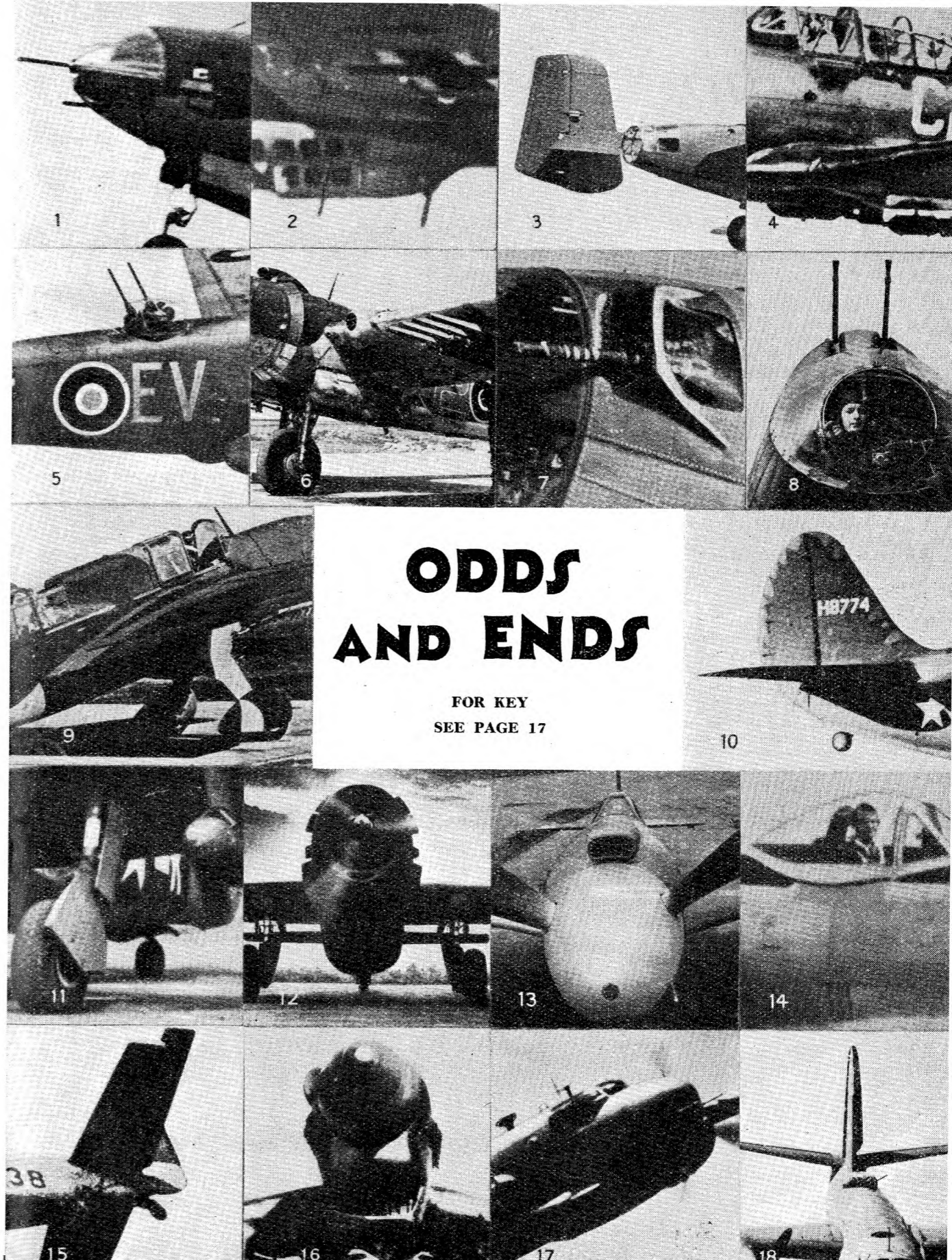

ODDS AND ENDS

FOR KEY
SEE PAGE 17

Flying Commentary

by The Editor

IN the dark days of 1940, the prayer on nearly everyones lips was for more aircraft, more aircrews, more squadrons, more bombs, more guns, more everything that would win the war in the air. Now we have got them and everyone rejoices that the Allied air forces are so strong, so well equipped and so highly trained that all the world is open to them, not entirely without opposition, but at least without any impossible barriers of enemy defence.

VICTORY FOR ALL

This enormous strength has been the result of the hard work and great sacrifice on the part of millions of people—the planners who planned so wisely and well, the workers who toiled night and day far from their homes, the ground staffs who did their duty at all times without the stimulus of flight or battle, and above all the splendid aircrews, who trained hard, fought hard, and sacrificed their lives or liberty without stint. There is still more hard work to be done and, unfortunately, still more lives to be lost. But our great strength and superiority over the enemy ensures that the casualties will not be so heavy as they have been or as they might have been. More of our friends will come home.

DISAPPOINTMENT FOR SOME

But the great achievement will bring some disappointment in its train. Many of the young men now

training for aircrew will find themselves for the time being at least, unwanted. It will be a bitter disappointment to many of them, that the flying career for which they are still striving should elude them, if only temporarily. But being intelligent and reasonable people they will accept the situation and treat this disappointment as their war sacrifice. Not one of them would wish to prolong the war by a day in order that he might take a part in it.

They have their counterpart and their example in an older generation which just missed the last war. That generation carried on during the years between the wars, getting little promotion and no glory, and then found itself just a little too old to achieve much promotion or many medals in this one. But they did their jobs and helped to build the foundation on which our air forces to-day are built. And in spite of their first disappointment they were not too unhappy in doing it.

THE NEED FOR CONTINUED TRAINING

They did something more. They formed the reserve which was never called upon, but which by its very existence was a pillar of our security. While war is possible, we shall need large numbers of young men ready to come to their country's defence, and though they may never be called up,

their efforts to train themselves for the hour of need will not be wasted. That is good enough reason, therefore, for continuing A.T.C. Training. The other good reason is that the Royal Air Force wisely continues to take at least some young men of each age group, so that ages throughout the Service are evenly balanced. You can be sure that it will prefer those who have shown their spirit and ability by training.

A GREAT SCHEME

Those who cannot get in the Air Force will welcome the news of the scheme now being launched by Air Commodore Sir Adrian Chamier, first Commandant of the A.T.C., and now Executive Controller of the Air League of the British Empire. It is called "Pennies for Planes." Briefly, the idea is that branches of the Air League should be formed all over this country and the Empire and people will be asked to subscribe to a great flying fund, which will enable nearly everyone to have some flying training. Sir Adrian sees post-war flying not merely as a matter of air transport and queues of air line passengers, but as a great upsurge of wings in which every young man (and many young women) will have the opportunities of flying themselves. The air over the Empire is wide. The need for air travel will be great. There will be room in it for everyone. It is a great idea and one in which every reader of this Gazette must be personally interested. Give it all the support you can. As you may want to help, I may mention that the address of the Air League is 1a Pall Mall East, London, S.W.1. Flying for everybody is a great idea, but great ideas need a great deal of money and organisation and a great number of enthusiastic workers. Count yourself among them.

The Spitfire P.R. XI.

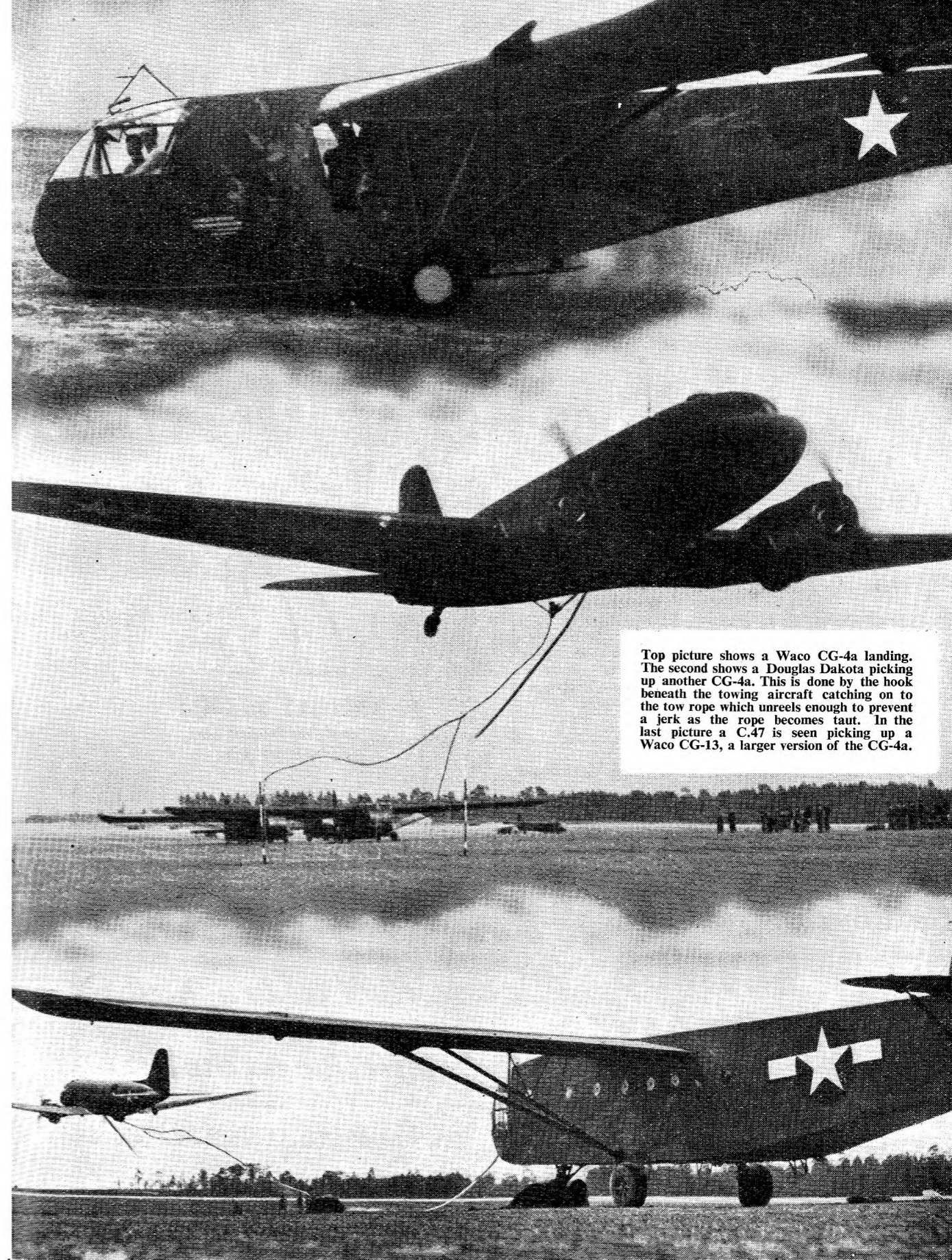
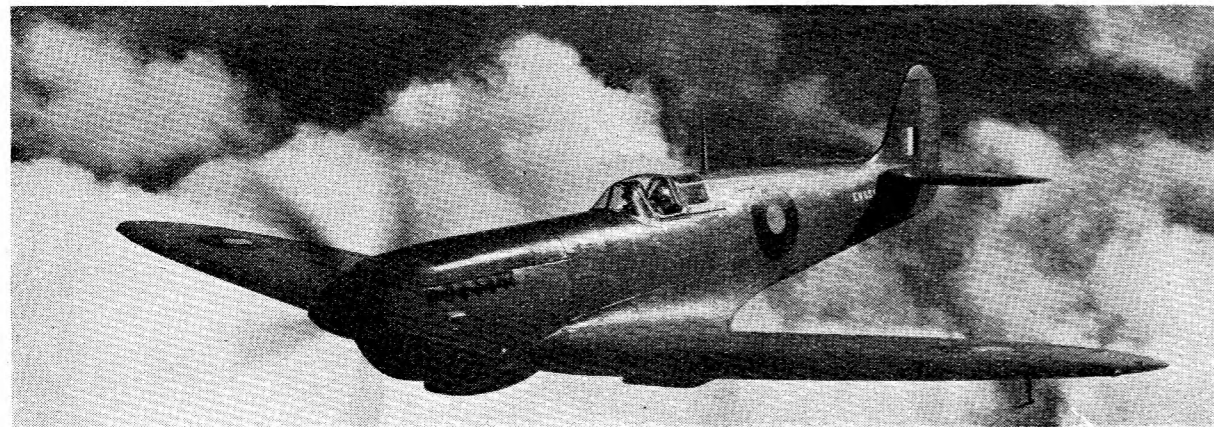

Top picture shows a Waco CG-4a landing. The second shows a Douglas Dakota picking up another CG-4a. This is done by the hook beneath the towing aircraft catching on to the tow rope which unreels enough to prevent a jerk as the rope becomes taut. In the last picture a C.47 is seen picking up a Waco CG-13, a larger version of the CG-4a.

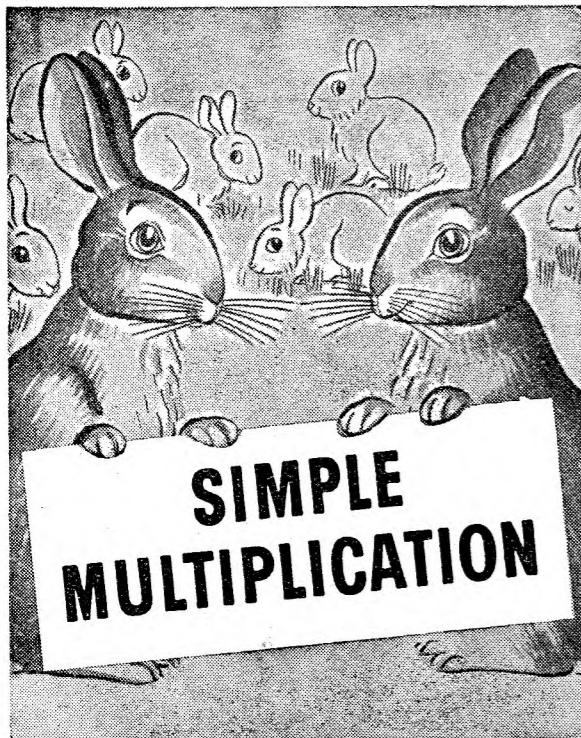

Take 15/- (the price of a Savings Certificate)—add 10 years (the period of its maturity) — result, 20/6. Multiply 15/- by 500 and the answer is £375. In 10 years £375 invested in Savings Certificates becomes £512.10.0—a profit, free of tax, of £137.10.0. . . . Why not let your savings multiply themselves this simple way ?

If you already hold your quota of 500 Certificates (issued at any price under £1) you can still save the Certificate way by acquiring up to 250 £1 Certificates.

Buy and hold NATIONAL SAVINGS CERTIFICATES

You can cash your Certificates at any time by giving a few days' notice.

Issued by the National Savings Committee

GIVE YOUR TEETH A SHINE WITH

Gibbs DENTIFRICE

7 1/2d

REFILLS 7d & 11 1/2d
(Including Purchase Tax)
Prices U.K. only.

NO MESS

NO WASTE

the last brushful is as effective as the first

D. & W. GIBBS LTD., LONDON, E.C.4. GD 236M



★ Vote of Confidence

THE CREAMIER LONG-LASTING LATHER OF PALMOLIVE SHAVING CREAM

*Softens the toughest beard
Smooths the way for razors
Soothes the tenderest skin*



★ WORLD'S LARGEST SALE 1/6 and 2/6 INCLUDING TAX



*Do you look lovely
when you smile?*

the Answer's on the tip of your tongue

Use Pepsodent. Then feel with your tongue how its super-cleansing Irium has flushed stain-collecting film clean away.

1/3 and 2/2 Including Tax
Also made in Powder Form

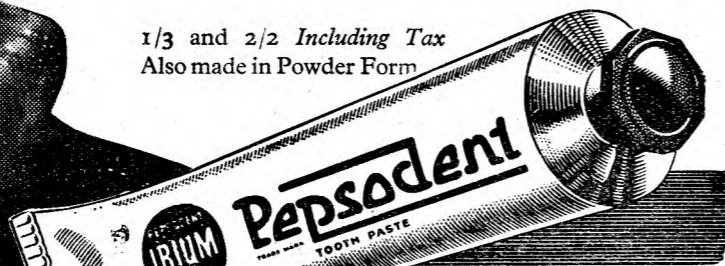

Thank goodness I always bought

'Viyella' SERVICE SHIRTS

Cool when it's hot—

warm when it's not



Comfortably soft to the skin, 'Viyella' Service Shirts have been on active service for half a century, and are still right for any battlefield, any climate. Made in regulation khaki, Air Force Blue and white.

A Guide to YOUTH LEADERSHIP

By C. R. HUMPHRIES

and

JOHN HUTCHESON

A BOOK WITH A PRACTICAL APPROACH Starting with an analysis of the qualities of leadership, the authors then proceed to give to the young cadet, to the leader-in-training and to the Training Officer, specific directions and working methods, suggestions and exercises.

The authors have a wide experience of handling their subject, and their writings are already well known to the cadets of pre-Service organisations.

1/3 net

METEOROLOGY for the Airman

By

JAMES PATON

A lucid treatment of the elementary physical principles required for an understanding of the weather processes. With many diagrams, charts and maps.

3/6 net

**UNIVERSITY OF LONDON
PRESS**

BICKLEY, KENT



Close Shave! The Standard Gillette Blade is an expert in getting to grips wherever the enemy is thickest. It makes smooth tracks through the heaviest going. It is made of fine steel — worthily carrying on the peace-time tradition of the famous Blue Gillettes.

Gillette in battledress

Gillette "Standard" and "Standard Thin" Blades (plain steel) 2d each, including Purchase Tax. Fit all Gillette razors, old or new.

If you can't always get them, remember they're worth trying for! Production still restricted.

PREPARING TO-DAY



FOR TO-MORROW



Healthy White Teeth

You're counting the days when you will be leaving the A.T.C. for the R.A.F. But there is that all-important 'medical' to get through. Are you sure your teeth will say the right things about you?

Remember: Teeth made white and gleaming with PHILLIPS' DENTAL MAGNESIA reveal clean, regular habits, regard for health and appearance. You need these qualities in the Service. But, even more important, teeth cleaned with PHILLIPS' DENTAL MAGNESIA mean a healthy mouth, consequently a sound digestion and 'top-notch' efficiency.

NOW is the time to start using PHILLIPS' DENTAL MAGNESIA. Get a tube today and use it night and morning.



Sold everywhere
1/1 & 1/10+

*Milk of Magnesia is the trade mark of Phillips' Preparation of Magnesia.

PITMAN BOOKS

AIRCRAFT MECHANIC'S POCKET BOOK

By John T. Henshaw, A.F.R.Ae.S. Provides ready reference to essential aircraft engineering data for mechanics, ground engineers, inspectors, and R.A.F. personnel engaged on maintenance duties. Sections covered include Materials, Drilling, Tapping and Reaming, Adhesives and Sealing Compounds, etc. 2s. 6d. net.

STAR RECOGNITION

By Joseph I. Fell, B.Sc.(Hons.). A book suitable for the aircraft student and navigator, rendering him capable of knowing the positions of the brightest stars, even though they might not always be visible. 2s. net.

MAPS AND ELEMENTARY METEOROLOGY FOR AIRMEN

By W. Myerscough. An excellent introduction for aircrews. Much attention is paid to the plotting of positions, and four large-scale plotting charts are supplied for practical work. The book is fully illustrated, and a number of self-examination questions are appended. Second Edition. 4s. 6d. net.

ELEMENTARY MATHEMATICS FOR WIRELESS OPERATORS

By W. E. Crook. Covers arithmetic, algebra, geometry and trigonometry, graphs and mechanics. Second Edition. 3s. 6d. net.

ENGLISH FOR AIRMEN

By A. R. Moon, M.A. Simple, practical instructions and exercises in English for pre-entry training for Air Force Cadets. Second Edition. 3s. net.

COMPLETE MORSE INSTRUCTOR

By F. Tait. A complete course for Service Trainees by an experienced operator. 2s. net.

BASIC CALCULATIONS FOR FITTER TRADES

By A. E. Druett, B.Sc.(Eng.) Lond., A.M.I. Mech.E. Applies to fitters and flight mechanics. 3s. 6d. net.

BASIC CALCULATIONS FOR RADIO, WIRELESS AND ELECTRICAL TRADES

By A. E. Druett. A companion volume to the foregoing. 3s. 6d. net.

FREE!

Please send me your free catalogue of Aeronautical Books (111 titles).

Name

Address

SEND THIS AT ONCE TO

PITMAN'S 39 PARKER STREET
KINGSWAY, W.C.2

Bj44

Training Cadets.

Involves a colossal amount of work, a large proportion of which, has to be duplicated. An Ellams Duplicator is an absolute necessity if time, labour and money are to be saved and efficiency kept at the high peak so vital to our Air Force of tomorrow

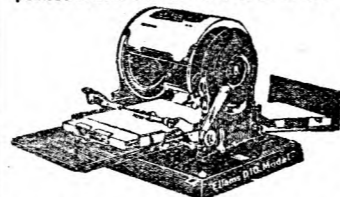

From one hand or typewritten original an Ellams duplicator will run off perfect copies of any Form, Letter, Document, etc., and can be relied upon to give long service and satisfaction.
WRITE FOR FULL PARTICULARS



ELLAMS DUPLICATOR CO., LTD.
Astor House, Aldwych, W.O.2 (Holborn 5388)
Bushy Hall Rd., Bushy, Herts. (Wat. 4211/4)
Makers of British Duplicating Equipment 50 years

MATRICULATION

brings Success & Security

Whatever your age, you can now study for the all-important Matriculation Examination at home on "NO PASS—NO FEE" terms. "MATRIC" is the accepted passport to all careers, and opens up opportunities which would otherwise be completely closed to you. Ensure the future success and security of you and yours by writing for our valuable "Guide to Matriculation" Immediately—FREE and post free.

B.T.I. (Dept. 311)

356, OXFORD STREET, LONDON, W.1

AERO MODELLERS

SEND

3d.

FOR LIST OF OVER

100 PLANS

of Aircraft, Ships and "OO" Railway features, and particulars of "Planbooks," including "Making Miniature Aircraft" and "Making Identification Models."

Enclose unstamped addressed envelope.

MODEL CRAFT LIMITED
77 (AT) Grosvenor Rd., London, S.W.1



Most aircraft are allotted to air forces. The Boeing Super Fortress (B-29) had an air force created for it. The U.S. Twentieth Air Force has been formed to organise the activities of this 141 ft. wing-span bomber now being produced in six of the largest U.S. factories. The four 2,200 h.p. Wright Cyclone engines give all-round improved performance, but landing speed is about the same as that of the Fortress. Chief recognition feature is the high aspect ratio wing, which will no doubt soon become familiar to the Japs in the Pacific, where the Twentieth will operate.

