

**As you are now the owner of this document which should have come to you for free, please consider making a donation of £1 or more for the upkeep of the (Radar) website which holds this document. I give my time for free, but it costs me around £300 a year to bring this document to you. You can donate here <https://blunham.com/Radar>, thank you.**

**Do not upload this copyright pdf document to any other website. Breaching copyright may result in a criminal conviction and large payment for Royalties.**

This document was generated by me, Colin Hinson, from a document held at R.A.F. Henlow Signals Museum which is believed to be out of copyright or Crown Copyright. It is presented here (for free) under the Open Government Licence (O.G.L.) if under Crown Copyright and this version of the document is my copyright (along with the Crown Copyright) in much the same way as a photograph would be. It should be noted that most of the pages are identifiable as having been processed by me. If you believe the original document to be under copyright, please contact me.

The document should have been downloaded from my website <https://blunham.com/Radar>, or any mirror site named on that site. If you downloaded it from elsewhere, please let me know (particularly if you were charged for it). You can contact me via my Genuki email page: <https://www.genuki.org.uk/big/eng/YKS/various?recipient=colin>

**You may not copy the file for onward transmission of the data nor attempt to make monetary gain by the use of these files. If you want someone else to have a copy of the file, point them at the website (<https://blunham.com/Radar>). Please do not point them at the file itself as it may move or the site may be updated.**

---

I put a lot of time into producing these files which is why you are met with this page when you open the file.

In order to generate this file, I need to scan the pages, split the double pages and remove any edge marks such as punch holes, clean up the pages, set the relevant pages to be all the same size and alignment. I then run Omnipage (OCR) to generate the searchable text and then generate the pdf file.

Hopefully after all that, I end up with a presentable file. If you find missing pages, pages in the wrong order, anything else wrong with the file or simply want to make a comment, please drop me a line (see above).

If you find the file(s) of use to you, you might like to make a donation for the upkeep of the website – see <https://blunham.com/Radar> for a link to do so.

*Colin Hinson*

*In the village of Blunham, Bedfordshire, UK.*

# TELEPRINTER AUTO-TRANSMITTER MODELS 6S/6 and 6S/6-M

## MAINTENANCE INSTRUCTIONS

(Issued April 1959)

*Creed & Company Limited*

TELEGRAPH HOUSE  
CROYDON, ENGLAND

*Telegraphic Address:*  
CREDO, TELEX, CROYDON

*Telephone:*  
MUNICIPAL 2424

*Telex:* 28836



## CONTENTS

	Page
INTRODUCTION .....	7
CHAPTER	
I    TECHNICAL DATA .....	8
II   NOTES ON INSTALLING AND OPERATING	
A.  Installing	
1.  Effects of transport .....	11
2.  Lubrication .....	11
3.  Connections .....	11
4.  Earths .....	11
5.  Testing .....	11
B.  Operating	
6.  Width of tape .....	11
7.  Inserting the tape .....	12
8.  Starting up .....	12
9.  Automatic controls and indicators .....	12
10.  Re-set mechanism .....	12
III  TESTING INSTRUCTIONS	
A.  Model 6S/6-M (magnetically-controlled clutch) .....	13
B.  Model 6S/6 (mechanically-controlled clutch) .....	13
IV   MAINTENANCE INSTRUCTIONS	
1.  After each 300 hours' working .....	14
2.  After each 900 hours' working .....	14
3.  After each 3,600 hours' working .....	14
V    DISMANTLING AND ASSEMBLING	
A.  To dismantle the machine into units .....	16
B.  To reassemble the units to the machine .....	17
C.  To dismantle the units into parts .....	17
D.  To reassemble the units .....	21
VI   UNIT ADJUSTMENT INSTRUCTIONS	
A.  Transmitter Head (all machines)	
1.  Peckers .....	22
2.  Start-stop lever .....	22

	Page
3. Tape gate .....	23
4. Tape gate latch .....	23
5. 'Gate-open' interlock .....	24
6. Tape guide .....	24
7. Tape-feed sprocket .....	24
8. Tape-feed pawl .....	25
9. Common selector lever (first setting) .....	25
10. Striker dart .....	26
11. Transmitting contacts .....	26
12. Common selector lever (final setting) .....	26
13. Jockey roller .....	27
14. Striker-operating arm .....	27
15. Tape-seeker lever .....	28
16. Tape-out latch lever .....	28
17. Tape-out latch control lever .....	28
18. 'Gate-open' trip arm spring .....	28
<b>B1. Tape Control Unit (all machines)</b>	
19. Clutch spindle bearing block .....	29
20. Gear wheel .....	29
21. Retention lever pivot .....	29
22. Retention roller pressure .....	30
23. Send-receive switch (if fitted) .....	30
24. Clutch pawls .....	31
<b>B2. Tape Control Unit (6S/6-M only)</b>	
25. Electromagnet .....	31
26. Electromagnet-mounting bracket .....	31
27. Electromagnet armature .....	32
28. Clutch detent .....	32
<b>B3. Tape Control Unit (6S/6 only)</b>	
29. Detent-mounting bracket .....	32
30. Detent-operating arm .....	33
<b>VII MACHINE ADJUSTMENT INSTRUCTIONS</b>	
<b>A. All Machines</b>	
31. Tape arm .....	34
32. Transmitter coupling .....	34
33. Clutch torque .....	35
34. Tape-out plunger and switch .....	35
<b>B. 6S/6-M (magnetically-controlled) machines</b>	
35. Taut-tape switch .....	35
<b>C. 6S/6 (mechanically-controlled) machines</b>	
36. Detent-operating lever .....	36

	Page
VIII MOTOR AND GOVERNOR INSTRUCTIONS	
A. Maintaining the Motor	
1. After each 300 hours' working .....	37
2. After each 900 hours' working .....	38
3. After each 3,600 hours' working .....	38
B. Dismantling and Reassembling the Motor	
1. Dismantling .....	39
2. Reassembling .....	40
C. Motor Adjustment Instructions	
37. Brush rocker .....	41
38. Brush boxes .....	41
39. Governor brushes .....	42
40. Governor contacts .....	42
41. Motor speed .....	42
IX LUBRICATING INSTRUCTIONS	
1. Lubricants .....	44
2. After each 300 hours' working .....	44
3. After each 900 hours' working .....	44
4. On dismantling after each 3,600 hours' working .....	45
X SPRING TENSIONS .....	46
XI CIRCUITRY	
1. Signal plug .....	49
2. Motor and governor circuit .....	49
XII LIST OF ITEMS .....	51

## ILLUSTRATIONS

Plate 1	Model 6S/6-M, covered
" 2	" " uncovered
" 3	" " underview
" 4	Transmitter head, front covers removed
" 5	" " rear cover removed
" 6	Model 6S/6, control unit
Fig. 1	Transmitter head, front view
" 2	" " rear view
" 3	} 6S/6 and 6S/6-M, tape-control unit adjustments
" 4	
" 5	
" 6	
" 7	
" 8	Tape-control unit
" 9	Send-receive switch
" 10	} 6S/6, tape-control unit adjustments
" 11	
" 12	} 6S/6 and 6S/6-M, machine adjustments
" 13	
" 14	
" 15	
" 16	Motor and governor diagrams
" 17	6S/6-M, circuit schematic diagrams
" 18	6S/6-M, electrical components diagrams

## INTRODUCTION

This 10th edition of Instruction Book No.33 deals with the latest models of the Creed striker-type automatic transmitter, the 6S/6 and the 6S/6-M. In the former, the clutch is mechanically controlled while, in the latter, it is magnetically controlled.

The main standard and optional features of the two models are outlined in chapter I.

The Book gives full information on maintaining the machines in good running order together with notes on installing and operating. Motor instructions are given in the three sections of chapter VIII, separate from those for the rest of the machine.

The layout of the Book is based on the machine maintenance instructions in chapter IV. These consist of three schedules giving respectively the work to be done after working periods of 300, 900 and 3,600 hours. Lubricating (chapter IX) and motor (chapter VIII) instructions are also divided in the same way and, in each maintenance schedule, reference is made to the sections of the adjustment, lubricating and motor instructions relevant to that schedule.

Thus after, say, the first period of 900 hours' working, all that is needed is to refer to section 2 of chapter IV and to the parts of chapters V, VI, VII, VIII and IX mentioned in that section. This arrangement avoids the repetition of detailed instructions common to different maintenance schedules.

Dismantling and assembling instructions are grouped in the four sections of chapter V into those relating to the removal from and replacement on the machine of complete units and those concerning the stripping down of units into their constituent parts and the reverse process.

Similarly, adjustment instructions are grouped into unit adjustments, chapter VI and inter-unit (machine) adjustments, chapter VII. Within these chapters there are sub-groupings covering the 6S/6 and 6S/6-M machines and adjustments common to both models.

Adjustment instructions are in the form of check/actions. In each particular case action need only be taken if the relevant check is unsatisfactory.

The two sections of chapter III contain testing instructions for application after installing and maintenance.

In chapter X there is a table of spring tensions so that springs can be tested freely if their functional response is not up to adjustment checks. Replacement springs can also be checked by the table.

Chapter XI gives a brief description of the internal circuitry of the 6S/6-M machine. This is similar to the 6S/6 but with the addition of the taut-tape micro-switch and the clutch magnet. Fig. 18 is a layout diagram of the electrical components with the items and their terminal points numbered. These numbers also appear on the schematic diagrams of Fig. 17 so that, by using the two figures together, it is a simple matter to trace and test the machine circuits.

In chapter XII there is a complete list of items (components, lubricating points etc.) mentioned and illustrated in the manual. Each item bears its own reference number throughout the text and illustrations. The list indicates the illustrations in which items are shown.

## I. TECHNICAL DATA

### A. MODEL 6S/6 (MECHANICALLY-CONTROLLED CLUTCH)

#### 1. Tape Width

Standard feature: An adjustment for handling either 11/16 in. (17.5 mms.) or 7/8 in. (22.2 mms.) tape.

#### 2. Transmission

(a) Standard feature: 7½-unit, 50 bauds, 1,500 r.p.m. motor, 10-stripe governor, 125 v.p.s. strobe.

(b) Optional features:

(i) 7½-unit, geared for 45.52 bauds, 1,500 r.p.m. motor, 10-stripe governor, 125 v.p.s. strobe.

(ii) 7½-unit, 75 bauds (uses 50-baud gears), 2,250 r.p.m. motor, 10-stripe governor, 125 v.p.s. strobe.

(iii) 7-unit, 50 bauds, 1,500 r.p.m. motor (geared for 7-unit), 10-stripe governor, 125 v.p.s. strobe.

#### 3. 'Tape-out' and 'Gate-open' indicator (Kit T.11)

Optional feature: Operates a microswitch which gives an electrical warning indication when the tape runs out or the tape gate is inadvertently opened.

#### 4. 'Taut-tape' arm

Standard feature:

(a) Used for starting and stopping the transmitter manually and,

(b) Automatically stops the transmitter if the tape is about to come under strain.

#### 5. Quick pick-up clutch

Standard feature: Cuts down the time delay between the dropping of the tape arm and the starting up of the transmitter.

#### 6. Send-receive switch (Kit C.4)

Standard feature for 7½-unit transmission. Can be used as phasing contacts.

#### 7. Chassis-mounted plugs

Standard feature: 12-pin signal plug, 4-pin power plug.

#### 8. Power Cord

Standard feature: With 3-pin 5A., G.E.C. plug at far end.

9. Signal Cord

Standard feature: Detachable either with:

- (a) B.P.O. 9-pin plug No. 903 at the far end or,
- (b) Painton 12-pin plug at the far end.

10. Radio interference suppression

Standard feature: B.P.O. improved, covering 200 Kc/s to 200 Mc/s.

11. Fuse

Standard feature: For motor protection.

12. Motor

Standard feature: Type KBE, either:

- (a) Ref. 510, 200/250V. DC/AC, 50 c/s and 160V. DC or,
- (b) Ref. 510, 100/125V. DC/AC, 50 c/s.

B. MODEL 6S/6-M (MAGNETICALLY-CONTROLLED CLUTCH)

13. Tape width

As in 1 above.

14. Transmission

As in 2(a) and 2(b) above.

15. 'Tape-out' and 'Gate-open' arrest (Kit T11)

Standard feature: Operates a microswitch which energises the clutch magnet and stops the transmitter when:

- (a) the tape runs out or,
- (b) the tape gate is inadvertently opened during transmission.

16. 'Taut-tape' arm

As in 4 above. Clutch control is via a microswitch and the clutch magnet.

17. Quick pick-up clutch

Standard feature:

- (a) As in 5 above and,
- (b) Cuts down time lag in pulse operation.

- 
18. **Send-receive switch (Kit C.4)**  
Optional feature: See 6 above.
  19. **Chassis-mounted plugs**  
See 7 above.
  20. **Power cord**  
As in 8 above.
  21. **Signal cord**  
Standard feature: as in 9(b) above.
  22. **Radio interference suppression**  
As in 10 above.
  23. **Fuse**  
As in 11 above.
  24. **Motor**  
As in 12 above.

## III. NOTES ON INSTALLING AND OPERATING

### A. INSTALLING

Note: All machines are properly lubricated, adjusted and tested before they leave the factory. They should, however, be checked before being placed in circuit to make sure they have not been affected by transport, storage or unpacking. Special attention should be given to the points below.

#### 1. Effects of transport

Check the machine carefully to make sure it has not been damaged in any way during transport. All machines are packed to withstand normal shocks but it is advisable to check this point.

#### 2. Lubrication

Check that lubrication is in accordance with the instructions in chapter IX.

#### 3. Connections

3.1 Check the fitting of and connections to all plugs and sockets. Check the clamping of cord sleeveings.

3.2 Make a general check of connections to electrical components and terminal blocks.

#### 4. Earths

Check that the safety and signal earths are effective and free from external noise.

#### 5. Testing

5.1 Turn the machine by hand and make a visual check of operation.

5.2 Carry out routine tests in chapter III relating to the type of machine in use

Note: Any necessary readjustments should be done as in chapters VI, VII and VIII.

### B. OPERATING

#### 6. Width of tape

6.1 The machine can be adjusted to take either 11/16 or 7/8 in. tape, as follows:-

6.2 For 7/8 in. tape, the flange of the tape-arm roller (138), Fig. 15, lies outwards and for 11/16 in. it lies inwards. If necessary, remove nut (137), withdraw the roller spindle and position the outer roller as required.

6.3 Similar action is taken in respect of flange (139), Fig. 14, or bracket roller (125).

- 6.4 For the wider tape, guide pin (17), Fig. 1, is pulled forward; for the narrower tape, it is pushed back.

## 7. Inserting the tape

- 7.1 Open the tape gate (14), Fig. 1, and raise the tape arm (113) to its latched position as shown in Fig. 11. Run the free end of the tape over bracket rollers (125), Fig. 14, undertape-arm rollers (134), (138), Fig. 15, and so on to the pecker guide plate (1), Fig. 1, inside pin (17).

Note: The right side up of the tape is that which puts the feed holes to the left of centre, looking from the free end.

- 7.2 Locate the feed holes over the tape-feed sprocket wheel and close and latch the tape gate (14).

## 8. Starting up

- 8.1 Start the transmitter by closing the motor switch (205), Fig. 18, and unlatching and lowering the tape arm to its 'run' position.

## 9. Automatic controls and indicators

### Taut-tape control (all machines)

- 9.1 If the tape tends to get dangerously tight, it lifts arm (113), Fig. 8, which arrests the clutch sleeve and stops the transmitter.
- 9.2 On model 6S/6 the clutch sleeve is arrested mechanically through lever (115), Fig. 10. On model 6S/6M the clutch sleeve is arrested magnetically through switch (128), Fig. 15, and magnet armature (97), Fig. 6.

### 'Tape-out' and 'gate-open' controls (6S/6M only)

- 9.3 If the tape runs out or the tape gate is accidentally unlatched during transmission, the transmitter can be stopped automatically through the action of plunger (112), Fig. 13, microswitch (123) and magnet armature (97), Fig. 6. Alternatively, item (123) can complete the circuit of a warning device.

### 'Tape-out' and 'gate-open' warnings (6S/6 only)

- 9.4 Instead of automatically stopping the transmitter, the action of plunger (122), Fig. 13, and switch (123) can be used to give an aural or visual indication of the 'tape-out' or 'gate-open' condition.

## 10. Re-set mechanism

- 10.1 When the conditions mentioned in 9.3 above have been rectified or attended to, the depression of button (119), Fig. 12, will cause arm (122) to latch down and re-set the transmitter or discontinue the warning.

### III. TESTING INSTRUCTIONS

Note: These tests should be made when the machine is installed and after any maintenance work has been done. If results are not satisfactory, appropriate action should be taken in accordance with the machine and/or unit adjustment instructions.

#### A. MODEL 6S/6M (MAGNETICALLY-CONTROLLED)

1. Insert a test length of punched tape in the transmitter and switch the motor on. Unlatch and lower the tape arm (113), Fig. 8. The transmitter should now run.
2. Put an increasing manual drag on the tape below the tape guide bracket (133), Fig. 14, and check that the transmitter stops when the tape arm is lifted to the taut-tape position.
3. Check that the tape can be drawn back by at least one feed-hole pitch from the 'stop' position before the tape arm touches the spring latch (126).
4. Let the tape run out and check that the transmitter stops automatically. Insert the tape again, close the tape gate and check that the transmitter re-starts when button (119), Fig. 12, is latched down.
5. Open the tape gate while the transmitter is running and check that it stops automatically. Close the tape gate and check that the transmitter re-starts when button (119) is latched down.

#### B. MODEL 6S/6 (MECHANICALLY-CONTROLLED)

6. Carry out tests 1, 2 and 3 above.
7. Let the tape run out and check that microswitch (123), Fig. 13, operates and the warning indicator (if connected) works. Rethread the tape, close the tape gate and latch down button (119), Fig. 12. Check that the switch de-operates and the warning ceases.
8. Open the tape gate while the transmitter is running. Check that switch (123) operates and the warning indicator (if connected) works. Close the tape gate and latch down button (119). Check that switch (123) de-operates and the warning stops.

Note: Tests 7 and 8 above are conditional upon the 'tape-out' optional facility being fitted.

## IV. MAINTENANCE INSTRUCTIONS

### 1. After each 300 hours' working

1.1 Remove the covers and dust the machine. Brush out paper dust from the transmitter head.

1.2 Clean and burnish the transmitting and send-receive contacts.

Note: If the contacts are pitted, they may be re-faced with a superfine file and a burnisher. Abrasives must not be used.

1.3 Check the jockey roller (29), Fig. 1, pressure and neutrality to paragraph 13, section A, chapter VI.

1.4 Carry out motor and governor instructions, paragraph 1, section A, chapter VIII.

1.5 Carry out lubricating instructions as in 2.1 of chapter IX.

1.6 Carry out routine tests in chapter III.

### 2. After each 900 hours' working

2.1 Carry out instructions 1.1 to 1.3 above. Renew the contacts if necessary.

2.2 Carry out all adjustments instructions in chapters VI and VII relating to the type of machine in use.

2.3 Carry out motor and governor instructions in paragraph 2, section A, chapter VIII.

2.4 Carry out lubrication instructions as in 3.1 and 3.2 of chapter IX.

2.5 Carry out routine tests in chapter III.

### 3. After each 3,600 hours' working

3.1 Dismantle the machine into units (section A, chapter V).

3.2 Dismantle the transmitter head and control unit into parts (section C of chapter V).

3.3 Thoroughly clean all parts and inspect them for wear. Obtain the necessary replacements.

Note: Worn parts should be replaced when reassembling instructions are being carried out.

#### Transmitter head

3.4 Carry out instruction 1.2 above or, if necessary, replace the contacts and tongues.

3.5 Replace the oil pad (57), Fig. 2, of the tape feed cam and of the transmitter cam (44), Fig. 1, if they show signs of wear.

N.B.: New pads must be impregnated in accordance with the lubrication instructions, section 4, chapter IX.

- 3.6 Replace the jockey roller (29), Fig. 1, if necessary.
- 3.7 Carry out reassembling instructions in section D of chapter V and the adjustment instructions in section A of chapter VI.
- 3.8 Carry out the lubrication instructions in section 4 of chapter IX.

#### Tape control unit

- 3.9 Reassemble the unit in accordance with the instructions in section D of chapter V and in sections B1 and B2 or B3 of chapter VI relevant to the type of machine in use. Renew, as necessary, any worn parts.
- 3.10 Carry out the lubrication instructions in section 4 of chapter IX.

#### Motor

- 3.11 Carry out motor and governor instructions in section A.3 of chapter VIII.

#### Complete machine

- 3.12 Carry out machine assembly instructions in accordance with section B of chapter V and adjust up to the instructions in chapter VII relevant to the type of machine in use.
- 3.13 Carry out the routine tests in sections A or B of chapter III according to the type of machine in use.

## V. DISMANTLING AND ASSEMBLING

N.B.: Red-painted screws should not be disturbed unless there is an instruction to do so.

### A. TO DISMANTLE THE MACHINE INTO UNITS

#### 1. Transmitter head, Plates 1, 2 and Figs. 1, 2, 4

1.1 Slacken the clamping screw (215), Plate 1, and withdraw the transmitter head (220) from its stand (121).

1.2 Remove the loose coupling disc (83), Plate 2.

N.B.: When replacing the transmitter head it is *most important* that the retention roller (85), Fig. 4, should be fully bedded in its recess in the clutch sleeve as shown and that the transmitter cam should be in the rest position with all the peckets down and the coupling dog vertical as in Fig. 2.

This precaution is necessary to ensure that the tape control unit and the transmitter are in phase.

#### 2. The motor, Plates 1, 2

2.1 Remove the machine cover (217), Plate 1, and the base cover (218).

2.2 Remove the guard over the governor brushes (233), Plate 2. Slacken the screws only.

2.3 Remove the governor (237).

2.4 Remove the guard over the driving gears (81) - two long and one short screws.

2.5 Remove the guard (230) around the governor contact block (three screws).

2.6 Remove the two screws securing the mounting block (231) of the drive-end motor support plate.

2.7 Remove the two 3/8 in. screws (228) fixing the governor-end motor support plate.

2.8 Lift and remove the motor (224) complete with support plates and block (231).

2.9 Slacken the clamping screws (223), (226) and remove the support plates from the motor.

#### 3. Tape control unit, Plate 2 and Figs. 8, 9, 15

Note: Instructions 3.1 and 3.2 apply to 6S/6-M (magnetically-controlled machines) only.

3.1 Unsolder the leads from microswitch (128), Fig. 15, noting their connecting points for reassembling.

- 3.2 Unsolder the two coil leads of magnet (140), Fig. 8.
- 3.3 Uncleat and disconnect the three leads (222), Plate 2, from the send-receive switch, Fig. 9 (if fitted), noting the connecting point of each wire for reassembling.

N.B.: As the terminal nuts of two of the leads also lock the contact screws, care must be taken not to disturb the setting of the contacts when removing or replacing the leads.

- 3.4 Remove the two securing screws and four washers and lift the tape control unit from the main base, paying the three send-receive switch wires (if fitted) carefully through the bushed hole in the base of the unit.

#### 4. Transmitter stand, Plate 1

- 4.1 Remove the two screws and clamping plate securing the 3-spring contact block to the transmitter stand, leaving the block supported by its leads.
- 4.2 Withdraw from the underside of the main base the two screws (219), Plate 1, securing the transmitter stand. Remove the stand and any shims between it and the base, noting the quantity for reassembling.

### B. TO REASSEMBLE THE UNITS TO THE MACHINE

5. Follow out the dismantling instructions in reverse, with particular attention to the passages dealing with reassembling. Carry out the machine adjustment instructions.

### C. TO DISMANTLE THE UNITS INTO PARTS

#### 6. Transmitter head, Plates 1, 2 and Figs. 1, 2

- 6.1 Remove the clip-on front cover (216), Plate 1.
- 6.2 Remove the rear cover plate (221), Plate 2.
- 6.3 Remove nut and washer (15), Fig. 1, and slide off the tape gate (14).

Note: If there are any shims on the tape gate hinge pin, note their positions and quantity for correct replacement when reassembling.

- 6.4 Take out the two screws (61), Fig. 2 (nuts in front), and remove the contact block (33), Fig. 1, complete.
- 6.5 Slacken the set screw (142), Fig. 2, in the tape-feed cam and withdraw the cam.
- 6.6 Extract the four screws (55), (62), (63) and (67), Fig. 2, and remove the front cover guide (34), Fig. 1.
- 6.7 Take off nut and washers (18), Fig. 1, and remove adjustable tape guide pin (17) together with its angle plate and 'S' spring (16).

- 6.8 Withdraw the sliding spindle (not shown) of the tape guide pin.
- 6.9 Take out the two fixing screws in pecker guide plate (1), Fig. 1, and remove the plate.

Note: To reassemble the pecker guide plate to the transmitter head, proceed as follows:

- (a) Place the pecker guide plate (1), Fig. 1, on its support blocks (3) and (13) and enter the right-hand fixing screw loosely. Centre the feed sprocket and the tape seeker in the slot in the plate.
  - (b) Keep a light pressure on the left-hand end of the guide plate and, using a springhook, enter the peckers in their respective holes.
  - (c) When all the peckers are in place, firmly press the guide plate on to its support blocks, and secure it with its fixing screws.
- 6.10 Remove spring (26), Fig. 1.
  - 6.11 Take off the retaining collar of striker lever (39) and remove the lever complete.
  - 6.12 Remove spring (25).
  - 6.13 Slacken the clamping screw (51), Fig. 2, in tape-feed ratchet wheel (52) and withdraw the wheel.
  - 6.14 Unanchor spring (54) and slacken collar (56). Remove feed-cam lubricator (57) complete with collar and spring.
  - 6.15 Remove screw pin (12), Fig. 1, and plate (2) - (two counter-sunk screws).
  - 6.16 Remove the 'gate-open' trip block and arm (19) and compression spring (20).

Note: When reassembling items (2), (12), (19) and (20) to the transmitter head, proceed as follows:-

- (a) Assemble the 'gate-open' trip block and arm (19) so that the top of the block lies just under the square cut-away in guide plate (1) and the arm lies under the tape-out lever. Take care not to displace the tape-seeker from its slot. See note 6.9(a) above.
- (b) The tape-out plunger (122), Fig. 13, which either stops the transmitter or gives a warning signal, is worked both by the tape-seeker lever and the 'gate-open' trip arm. If either rises due (i) to the absence of tape over the peckers or (ii) to the tape gate opening, the tape-out plunger is operated.
- (c) Mount the compression spring (20), Fig. 1, on its pin in the camshaft bearing plate (45) and assemble the plate to the unit, locating the spring under the block (19) while holding the block in its approximate position. Tighten up the securing screws of plate (45).

- (d) Still holding block (19) in its approximate position, assemble plate (2), Fig. 1, to the unit. Insert and tighten up guide pin (12) in block (19). Insert and tighten up the fixing screws of latch plate (2). Test the action of the 'gate-open' trip mechanism.
- (e) Turn the transmitter camshaft in its normal direction and test the action of the peckers and the tape seeker.

- 6.17 Withdraw the tape-feed sprocket wheel and spindle complete.
- 6.18 Release springs (65) and (66), Fig. 2, from their anchor pins.
- 6.19 Slacken collar screw (60) retaining feed pawl lever (64) and retention lever (50) and remove the levers, springs and collar.
- 6.20 Withdraw the two cheese-headed screws securing the transmitter cam bearing plate (45), Fig. 1, and remove the plate (for reassembling, see note to 6.16 above).
- 6.21 Release the spring of the tape-seeker lever (21), Fig. 1, from its anchor.
- 6.22 Remove the Anderton clip retaining the transmitting cam lubricator (309), Plate 4, and withdraw the lubricator.
- 6.23 Remove the block (13), Fig. 1 (one 1-3/8 in. screw).
- 6.24 Remove the tape seeker (not shown), together with its lever and springs.
- 6.25 Slacken the collar retaining the common selector lever assembly (22) and remove the assembly complete including the collar and lubricating washer.
- 6.26 Slacken the screw securing the pocker-spring anchor block (3), Fig. 1, and unhook the springs from the block.
- 6.27 Slacken the set screw in the body of the transmitting cam (44) and withdraw the camshaft. Lift out the cam.
- 6.28 Remove the spring clip (43) retaining the pecker levers on their common spindle.
- 6.29 Remove the two screws holding the pecker lever guide (40) and remove the guide.
- 6.30 Withdraw from their spindle, one by one, the five pecker levers (42) with their peckers and springs and the start-stop lever (23) (third from rear) with its spring.

Note: Mark the levers as they are removed as it is important they should be replaced in their original order when reassembling.

Remove the spacing washer behind the rearmost lever.

- 6.31 Remove block (3), Fig. 1 (one 1-3/8 in. screw).
- 6.32 Slacken the screw (31) of stop plate (30) and remove the plate.

- 6.33 At the rear of the transmitter head, remove springs (70) and (47).
- 6.34 Withdraw the Anderton clips retaining the tape-out levers (69) and (49) and remove the levers.

#### 7. Tape control unit (6S/6-M - magnetic), Figs. 3-9 and 15

- 7.1 Remove the spring (112), Fig. 8, and the Anderton clip round pivot bar (118). Withdraw the tape arm (113).
- 7.2 Remove the rear nut (127), Fig. 15, locking the pivot bar and, using a tommy pin in the holes provided, unscrew the bar.
- 7.3 Extract the two screws (131) and remove the mounting plate (130) together with microswitch (128).

Note: The two screws are of different lengths. Note their positions for reassembling.

- 7.4 Extract the two screws (101) and (108), Fig. 9, and remove mounting plate (103) together with the send/receive switch and its insulating pad.
- 7.5 Remove the tension spring (105), Fig. 9, and the Anderton clip retaining the retention arm (111), Fig. 4. Withdraw the arm from its pivot pin.
- 7.6 Slacken screw (87), Fig. 4, and withdraw the eccentric pin (88) from the casting.
- 7.7 Remove the screw (95), Fig. 7, and washers and the screw-in spring anchor (94). Remove plate (96) complete with the electro-magnet (140), Fig. 8, and the clutch detent lever (86).
- 7.8 Extract the large single screw (79), Fig. 3, holding the clutch spindle bearing block (78) to the casting (82) and remove the block and clutch.
- 7.9 Remove the magnet armature spring (98), Fig. 6. Extract the two screws (92) and remove the electro-magnet and its clamping plate.
- 7.10 Remove the Anderton clip (143) and free the clutch detent lever (86) from its spring (100), Fig. 8. Remove item (86) and then (100).

N.B.: When carrying out instructions 7.11 to 7.16 below, carefully note the number and positions of any shims removed so that they may be correctly replaced when reassembling the unit.

- 7.11 Slacken clamp screw (144), Fig. 5, and withdraw the driving arm (97) of the clutch gear wheel.
- 7.12 Withdraw the gear wheel (81), Fig. 3, from the clutch shaft. Withdraw the clutch (77), the felt oiling washer (145) and the clutch spindle from the bearing block (78).
- 7.13 Extract the three 6BA screws holding the bearing boss (146) to block (78) and remove the boss.
- 7.14 Extract the clutch hand (135), Fig. 5, from the gear wheel.

7.15 Temporarily re-clamp driving arm (97), Fig. 5, on the clutch shaft and use it as a grip to extract screw (147), Fig. 7. Withdraw the clutch sleeve (77) from the shaft.

7.16 Withdraw the twin ratchet wheel from the clutch sleeve.

8. Tape-control unit (6S/6 - mechanical), Figs. 10 and 11

8.1 Remove springs (112) and (136), Fig. 10, and Anderton clip (148). Withdraw the tape arm (113) together with detent operating arm (115).

8.2 Carry out 7.2 above.

8.3 If a send-receive switch is fitted, carry out 7.4 above.

8.4 Carry out 7.5 and 7.6 above.

8.5 Remove screw (95), Fig. 10, together with washers, and withdraw screw-in anchorpin (94). Remove plate (96) complete with clutch detent lever (86).

8.6 Carry out 7.8 above.

8.7 Remove clip (143), Fig. 11, and withdraw the clutch detent lever (86).

8.8 Note the N.B. preceding 7.11 above.

8.9 Carry out 7.11 to 7.16 above.

D. TO REASSEMBLE THE UNITS

9. Follow out the dismantling instructions in reverse, paying particular attention to the notes dealing with reassembling. Carry out the unit adjustment instructions.

## VI. UNIT ADJUSTMENT INSTRUCTIONS

Note: These adjustments are for the individual units of the machine. If it is necessary to remove a unit, follow the relevant dismantling, assembling and machine adjustment instructions. Do not disturb red-painted screws unless there is an instruction to do so.

### A. TRANSMITTER HEAD (ALL MACHINES)

#### 1. Peckers, Fig. 1

##### Check

- 1.1 Remove the front and rear covers and open the tape gate.
- 1.2 Turn the cam (44) in its normal direction until pecker No. 1 is fully raised.
- 1.3 Set a pre-set spring tension gauge to 180 gms. and apply the end of the arm to the top of the pecker.
- 1.4 Press the pecker downwards and check that the gauge arm does not lift from its stop until the pecker is fully down.
- 1.5 Set the gauge to 165 gms. and fully depress the pecker with the gauge arm.
- 1.6 Slowly lessen the pressure and check that the gauge arm does not touch its stop as the pecker begins to rise.

##### Action

- 1.7 If either or both checks 1.4 and 1.6 are not satisfied, adjust the innermost screw (46) as necessary, turning it clockwise to increase the pecker tension and vice versa.
- 1.8 Repeat the above check/actions with peckers Nos. 2, 3, 4 and 5, adjusting the relevant screw (46) as necessary.

#### 2. Start-stop lever, Fig. 1

##### Check

- 2.1 Turn the cam (44) until the start-stop lever (23) - the third from the rear - is fully depressed by its track.
- 2.2 Temporarily remove spring (26) and striker lever assembly (24).
- 2.3 Set the pre-set gauge to 165 gms. and apply the tip of the arm to the end of lever (23).
- 2.4 Press downwards and check that the lever (23) parts from the cam before the gauge arm lifts from its stop.
- 2.5 Set the gauge to 150 gms. and depress lever (23) with the gauge arm.

- 2.6 Slowly release the pressure and check that the gauge arm does not touch its stop before the lever touches the cam.

#### Action

- 2.7 If either or both checks 2.4 and 2.6 are not satisfied, carry out action 1.7 above to the third screw (46) from the rear of the unit.

N.B.: If there is undue difficulty in getting the above adjustments, it will probably be due to excessive friction at the pecker lever fulcrum or fouling of the tension springs. If necessary, these points should be checked and remedied.

The pecker spring tensions given are for use with standard tape supplied by Creed & Company. If some other kind of tape is used, the tensions will be different.

### 3. Tape gate, Fig. 1

#### Check

- 3.1 Unlatch the tape gate (14) and, keeping the latch (5) away from its pin (7), hold the gate firmly closed with the fingers.
- 3.2 Check that the clearance between the grill on the underside of the tape gate and the pecker guide plate (1), i.e. distance 'a', is .010 to .012 in. (.25 to .30 mm.).

#### Action

- 3.3 If this is not so, unlock screw (8) and adjust it to give a gap of .011 in. (28 mm.). Re-lock screw (8).

### 4. Tape gate latch, Fig. 1

#### Check

- 4.1 Unlatch the tape gate (14) and fully depress screw pin (12).
- 4.2 Hold the unit upright and raise the tape gate to an angle of 45<sup>0</sup>.
- 4.3 Release the gate and check that it latches securely under its own weight.

#### Action

- 4.4 If it does not, proceed as follows:-
  - (a) Slacken the nut at the rear of the eccentric latch pivot (6) and, with the tape gate closed, adjust the pivot so that the hook of the latch lever engages pin (7). Re-tighten the pivot lock nut.
  - (b) Hold the screw pin (12) fully depressed. Unlatch the tape gate and, with the unit held upright, allow the latch lever (5) to rest against the pin (7). Slacken screw (10) and adjust the stop plate (11) so that the centre of the 'D' of the lever touches pin (7). Retighten screw (10).
  - (c) Repeat check and refine action if necessary.

## 5. 'Gate-open' interlock, Figs. 1 and 2

Note: This device prevents the transmitter working when the tape gate is open.

### Check

- 5.1 Latch the tape gate and turn the transmitter cam (44), Fig. 1, until the tape-seeker lever (21) - shown broken - is fully depressed by its cam track.
- 5.2 Unlock screw (9) and turn it slowly anti-clockwise.
- 5.3 Check that after one-and-a-half turns the lever (69), Fig. 2, disengages from the lower step in lever (49) and falls against the upper step.

### Action

- 5.4 If this is not so, hold the lever (49) partly depressed in the direction of the arrow and adjust screw (9), Fig. 1, so that lever (69), Fig. 2, just catches the lower step of lever (49).
- 5.5 Turn the screw (9), Fig. 1, a full turn clockwise (inwards) and relock it.
- 5.6 Repeat the check and refine the action if necessary.

## 6. Tape guide, Fig. 1

### Check

- 6.1 Check that a clearance 'b', i.e. .015 in. (.38 mm.), exists between the foot of the tape guide plate (4) and the pecker guide plate (1).

### Action

- 6.2 If this is not so, slacken the two screws holding the tape guide (4) and, using a .015 in. feeler gauge, adjust it for the required clearance. Re-tighten the fixing screws.

## 7. Tape-feed sprocket, Fig. 2

### Check

- 7.1 Turn the transmitter cam in its normal direction until all the peckers are down.
- 7.2 Insert a piece of 'all-mark' tape in the unit and latch the tape gate.
- 7.3 Check by eye that, when the tape-feed wheel (52) is located by the retention lever (50), the tape perforations are centrally over the pecker holes.

### Action

- 7.4 If they are not, slacken clamping screw (51) and gently pull on the tape to get the required conditions. Re-tighten screw (51).

## 8. Tape-feed pawl, Fig. 2

### Check

- 8.1 Turn the transmitter cam in its normal direction until all the peckers are down and the coupling dog and set screw (142) are lying in the directions shown.
- 8.2 Check that there is a gap of .032 to .047 in. (.81 to 1.2 mms.), i.e. clearance 'c', between the feed pawl and the tooth face.

### Action

8.3 If this is not so, proceed as follows:-

- (a) Slacken screw (59) and push feed pawl (48) as far to the right as it will go.
- (b) Hold the lubricator arm (57) aside and insert a .021 in. (.53 mm.) feeler gauge between the feed cam (53) and the follower (58).
- (c) Press the follower (58) against the feeler gauge and move the pawl (48) to the left until it is fully bedded between two teeth of the ratchet (52). Retighten screw (59).

Note: The above action is designed to give the condition specified in 8.2 above.

## 9. Common selector lever (first setting), Fig. 1

### Check

- 9.1 Turn the cam by hand in its normal direction until two adjacent peckers protrude equally above guide plate (1), thus bringing the selector lever (22) to the midpoint of its travel.
- 9.2 Check by eye that the upturned end of stop plate (30) is lying central to the longer axis of slot (28).

### Action

- 9.3 If this is not so, slacken screw (31) and adjust stop plate (30) as required. Re-tighten screw (31).

### Check

- 9.4 Turn the transmitter cam in its normal direction till all the peckers are down and the striker dart (27) is fully withdrawn from tongue (37).
- 9.5 Check that the force needed to lift the end of lever (22) from the pecker levers against the pull of spring (25) is 60 to 70 gms.

### Action

- 9.6 If this is not so, and no mechanical defect is present, change spring (25).

## 10 Striker dart, Fig. 1

### Check

- 10.1 With the conditions as in 9.1 above, unanchor spring (36) and swing the jockey roller arm (29) clockwise.
- 10.2 Unlock contact screws (35) and (38) and adjust them so that they lightly clamp the knife edge of transmitting tongue (37) directly in line with that of the striker dart (27).
- 10.3 Check that the clearance between the two knife edges is .007 to .010 in. (.18 to .25 mm.).

### Action

- 10.4 If this is not so, slacken screw (41) and swivel striker plate (24) to get the required clearance. Re-tighten screw (41).
- 10.5 Open out the 'space' contact (38) to give a gap between it and the tongue contact (when the tongue is resting against contact screw (35) ) of .003 in. (.08 mm.).
- 10.6 Open out the 'mark' contact screw (35) to give a gap between it and the tongue contact (when the tongue is resting against contact screw (38) ) of .006 in. (.15 mm.). Re-lock both the contact screws.

## 11. Transmitting contacts, Fig. 1

### Check

- 11.1 Check that the contact screws (35) and (38) are adjusted to the gaps given in 10.5 and 10.6 above.

### Action

- 11.2 If they are not, slacken the clamping screws to friction tightness and do the necessary adjustments, taking care to adjust both contact screws by equal amounts so that, in its mid-position, the tongue (37) is in line with the striker dart (27).

- 11.3 Re-clamp the contact screws

## 12. Common selector lever (final setting), Fig. 1

### Check

- 12.1 Punch a length of tape with the letter 'Y' (1-3-5) and insert it in the transmitter head. Turn the cam slowly in its working direction and note that the dart (27) strikes equally on both sides of the tongue (37).

### Action

- 12.2 If it does not, slacken the screw (31) and refine the position of stop plate (30) to get the required conditions.

Note: To equalize the strikes, the plate (30) should be moved towards the side of the tongue which is receiving the shallower strike.

12.3 Re-tighten screw (31).

### 13. Jockey roller, Fig. 1

#### Check

13.1 Return the jockey roller arm (29) to its working position and refit the spring (36), taking care that it lies in its anchor grooves.

13.2 Turn the camshaft by hand until the dart (27) is fully withdrawn from the tongue (37) and check that the pressures needed to move the tongue from 'mark' to 'space' and vice versa do not differ by more than 5 gms., measured at the tip of the tongue.

#### Action

13.3 If this is not so, slacken the clamp screw of eccentric pivot (32) and adjust the position of the jockey roller to get the required conditions. Re-clamp the pivot.

Note: To equalize the pressures, move the jockey roller in the direction of the lighter pressure.

#### Check

13.4 Check that the force needed to move the tongue from one contact to the other is between 100 and 120 gms.

#### Action

13.5 If it is more than 120 gms. screw in both contacts *equally*. If it is less than 100 gms., screw both contacts out *equally*.

Note: Equal adjustment of both contact screws is essential in order to preserve the mid-position alignment of the tongue and the striker dart.

The total contact gap must not be less than .005 in. (.13 mm.) or more than .006 (.18 mm.) and the change-over forces must satisfy 13.2 above.

13.6 If conditions 13.2 and 13.4 cannot be satisfied by the above actions, change spring (36) and repeat the adjustments.

### 14. Striker-operating arm, Fig. 1

#### Check

14.1 Turn the transmitter cam in its normal direction till the cam-following point of striker lever (24) has just dropped off a tooth and moved the tongue (37) against the 'mark' contact (35).

14.2 Check that the force required to move the striker dart (27) away from the tongue is 90 to 120 gms. measured at the striker end of lever (24).

#### Action

14.3 If this is not so, and no mechanical defect is present, change the spring (26).

15. Tape-seeker Lever, Fig. 1

Check

- 15.1 Turn the cam to its rest position (all peckers down and tape-feed action just ended).
- 15.2 Check that the force required to move the seeker lever (21) - shown broken - away from the cam, measured at point A, is 70 to 110 gms.
- 15.3 If this is not so, and no mechanical defect exists, change the tension spring (not shown) of lever (21).

16. Tape-out latch lever, Fig. 2

Check

- 16.1 With the tape-seeker probe down, the tape gate closed and the levers (49) and (69) engaged as shown, check that a force of 45 to 65 gms., applied at 'B' in the direction of the arrow, is needed just to disengage the levers.

Action

- 16.2 If this is not so, and no mechanical defect is present, change spring (70).

17. Tape-out latch control lever, Fig. 2

Check

- 17.1 Depress lever (49) just enough to lift the lower step from the end of lever (69).
- 17.2 Check that a force of 13 to 25 gms., applied at point 'D' in the direction of the arrow, is needed to move lever (69) away from lever (49).

Action

- 17.3 If this is not so, and no mechanical defect exists, change spring (47).

18. 'Gate-open' trip arm spring, Fig. 1

Check

- 18.1 Latch the tape gate and mark with a pencil on plate (2) the position of screw pin (12). Open the tape gate.
- 18.2 Check that a force of not less than 250 gms., applied perpendicularly to the top face of block (19), is needed to depress the screw pin (12) to the pencil mark.

Action

- 18.3 If this is not so, and no mechanical defect is present, change compression spring (20).

## BI. TAPE CONTROL UNIT (ALL MACHINES)

### 19. Clutch-spindle bearing block, Fig. 3 and Fig. 9

#### Check

- 19.1 Place a straightedge across the coupling-end face of the clutch and check that the face protrudes 1.053 to 1.059 ins. (26.75 to 26.90 mms.) beyond the face of the control unit casting, i.e. distance 'd'.

#### Action

- 19.2 If it does not, remove the send/receive switch (if fitted), slacken screw (79), Fig. 3, securing the bearing block (78) to the casting (82) and adjust the position of the block to give the required distance, taking care to keep it pressed firmly against face 'E' of the casting. Re-tighten screw (79).

Note: To remove the send/receive switch, remove screws (101), Fig. 9, and (108) and remove the switch complete with its mounting plate.

- 19.3 Replace the send/receive switch (if fitted).

### 20. Gear wheel, Figs. 3 and 5

#### Check

- 20.1 Check that there is a clearance of .002 to .008 in. (.05 to .20 mm.) between the bearing boss (80) and the gear wheel (81).

#### Action

- 20.2 If this is not so, slacken the clamping screw (144) of the driving arm (97) and insert a .005 in. (.13 mm.) feeler gauge between the bearing boss and the gear wheel.

- 20.3 Press the clutch sleeve (77) from the coupling and against the bearing block (78) and hold the gear wheel firmly against the feeler gauge.

- 20.4 Move the driving arm (97) hard up against the boss of the gear wheel and tighten up clamp screw (144). Remove the feeler gauge.

N.B.: There are two .005 in. (.13 mm.) shims (110) between the driving arm and the gear wheel. Make sure these are in place before completing the adjustment.

### 21. Retention-lever pivot, Fig. 4

#### Check

- 21.1 With the detent lever (86) in the rest position, turn the clutch sleeve in its normal direction until the retention roller (85) is fully bedded in the recess on its cam track.

- 21.2 Hold the clutch sleeve rigid in this position by pressing hard on the retention roller, and push the pawls (89) as far away from the detent as they will go. Check that the clearance between the pawls and the detent is .002 to .004 in. (.05 to .10 mm.), i.e. distance 'g'.

Action

21.3 If this is not so, slacken screw (87) and, using a 3/16 in. spanner, adjust the eccentric pivot (88) of the retention arm (111) so that the required conditions are obtained. Retighten screw (87).

22. Retention-roller pressure, Fig. 8

Note: If a send/receive switch is fitted, remove screws (101) and (108) and the switch, together with its mounting plate (103). Re-fit it when the adjustment is done.

Check

22.1 Turn the clutch sleeve so that the retention recess (99) is away from the retention roller (85) as shown.

22.2 Check that a force of 320 to 450 gms., applied to the retention lever at and in the direction of the arrow, is needed to lift the roller from the cam.

Action

22.3 If this is not so, and no mechanical defect exists, change the spring (105).

23. Send-receive switch (if fitted), Figs. 8 and 9

Check

23.1 With the retention roller (85) fully bedded in its recess, check that the gap between the tongue (106) and the 'Send' contact (107) is .008 to .010 in. (.20 to .25 mm.).

23.2 With the recess (99) turned away from the roller as shown, check that the gap between the tongue and the 'Receive' contact (104) is also .008 to .010 in.

Action

23.3 If either or both the above checks are not satisfied, proceed as follows:-

(a) Slacken off the locknuts (102) and (109) and partly retract the contact screws (104) and (107).

(b) Turn the clutch sleeve till item (99) is away from item (85).

(c) Adjust contact (107) so that it just touches the tongue contact. Temporarily lock contact (107).

(d) Adjust contact (104) for a gap of .020 in. (.51 mm.) between it and the tongue contact. Lock item (104).

(e) Turn the clutch sleeve until the roller (85) is fully bedded in recess (99). Unlock 'Send' contact (107) and adjust it for a gap of .008 in. (.20 mm.) between it and the tongue contact. Lock item (107).

## 24. Clutch pawls, Fig. 8

### Check

- 24.1 Turn the clutch sleeve (77) in its normal direction till the pawls (89) are uppermost as shown. Check that a force of 71 to 92 gms., applied to each pawl at and in the direction of the arrow, is needed to press the pawl backwards to its stop.

### Action

- 24.3 If this is not so, and no mechanical fault is present, change the pawl spring.

## B2. TAPE CONTROL UNIT (6S/6-M ONLY)

## 25. Electromagnet, Fig. 6

### Check

- 25.1 Turn the clutch sleeve so that the pawls are away from detent (86) and the detent lever is at rest against its stop pin (91).
- 25.2 With the electromagnet armature in its unoperated position as shown, check that the clearance 'h' between the heel of the detent and the armature roller (93) is .012 to .017 in. (.30 to .43 mm.).

### Action

- 25.3 If this is not so, slacken the screws (92) and move the magnet away from the detent arm. Insert a .015 in. (.38 mm.) feeler gauge between the heel of the detent and roller (93) and position the magnet to a .015 in. clearance under the required conditions.
- 25.4 Re-tighten screws (92) and withdraw the gauge. Re-check the adjustment and refine if necessary.

## 26. Electromagnet-mounting bracket, Fig. 7

### Check

- 26.1 Turn the clutch sleeve (77) in its normal direction till it is arrested by the detent (86). Operate the electromagnet armature by hand.
- 26.2 Check that the clearance 'j' between the pawls (89) and the detent (86) is .001 to .004 in. (.03 to .10 mm.).

### Action

- 26.3 If this is not so, remove spring (112), if not already done, and slacken screw anchor pin (94) and screw (95). Swivel plate (96) about screw (95) so that, measured with a feeler gauge, a clearance of .003 in. (.08 mm.) is obtained under the required conditions. Re-tighten items (94) and (95), remove the feeler gauge and replace spring (112).

27. Electromagnet armature, Fig. 6

Check

27.1 Operate detent (86) by hand and check that a force of 20 to 30 gms., applied to the roller (93) of the armature (71) in the direction of the arrow, is needed to move the armature from its rest position.

Action

27.2 If this is not so, and no mechanical defect exists, change spring (98).

28. Clutch detent, Fig. 8

Check

28.1 Turn the clutch sleeve (77) in its working direction till the pawls (89) are clear of the detent (86).

28.2 Check that a force of 20 to 35 gms., applied at and in the direction of the arrow, is needed to lift the detent arm from its stop (91).

Action

28.3 If this is not so, and no mechanical defect exists, remove the detent and change spring (100).

28.4 Replace the detent and repeat check/action as necessary.

B3. TAPE CONTROL UNIT (6S/6 ONLY)

29. Detent-mounting bracket, Fig. 10

Check

29.1 Lower the tape arm (113) so that the detent (86) is touching the lower side of stop pin (91).

29.2 Turn the clutch sleeve (77) till the pawls (89) are in the position shown and check that clearance 'k' is .001 to .004 in. (.3 to .10 mm.).

Action

29.3 If this is not so, remove spring (112) and slacken screw anchor pin (94) and screw (95). Swivel mounting bracket (96) about screw (95) so that, measured with a feeler gauge, a clearance of .003 in. (.08 mm.) is obtained under the required conditions.

29.4 Re-tighten items (94) and (95), withdraw the feeler gauge and replace spring (112).

30. Detent-operating arm, Figs. 10 and 11

Check

- 30.1 Latch the tape arm (113) as shown so that the detent arm (86) is touching the top side of stop pin (91). Turn the clutch sleeve so that the pawls (89) are away from the detent.
- 30.2 Check that the roller of arm (115) is just touching the upper cam face of the detent arm, i.e. without arresting it.

Action

- 30.3 If this is not so, slacken nut (114) and adjust the eccentric pivot of the roller to get the required conditions. Re-tighten nut (114).

Check

- 30.4 Check that the arm (115) moves freely up and down without side play at the pivot.

Action

- 30.5 If this is not so, slacken set screw (116) and adjust collar (117) to get the required conditions. Re-tighten screw (116).

## VII. MACHINE ADJUSTMENT INSTRUCTIONS

Note: These inter-unit adjustments are for the assembled machine.

Do not disturb red-painted screws unless there is an instruction to do so.

### A. ALL MACHINES

#### 31. Tape arm, Figs. 8 and 15

##### Check

31.1 Check that the tape arm (113) moves freely up and down without end play at the pivot.

##### Action

31.2 If this is not so, slacken the locknut (127) at the rear of pivot rod (118) and, using a tommy pin in the holes provided, adjust the pivot rod as necessary. Re-tighten the lock nut.

##### Check

31.3 Check that the following forces, applied at and in the direction of the arrow, are needed to lift the tape arm (113), Fig. 15, from the stop bracket (133):-

(a) For magnetically-controlled machines, 35 to 55 gms.

(b) For mechanically-controlled machines, 45 to 65 gms.

##### Action

31.4 If this is not so, and no mechanical defect exists, change the spring (112), Fig. 8.

#### 32. Transmitter coupling, Fig. 3

##### Check

32.1 Check that, with the coupling disc (83) abutting the clutch sleeve coupling dog (77), there is a gap of .002 to .008 in. (.05 to .20 mm.) between item (83) and the transmitter coupling dog (84).

##### Action

32.2 If this is not so, locate the transmitter head in its stand to get a gap of .005 in. (.13 mm.) measured with a feeler gauge. Re-tighten the transmitter clamping screw securely.

33. Clutch torque, Fig. 5

Check

- 33.1 Turn the motor by hand in its normal direction and check that a force of 1500 to 2600 gms. (2300 to 4000 gm./cms.), applied to the outer end of driving arm (97) and tangential to the arc of movement, is needed to prevent the arm turning.

Action

- 33.2 If this is not so, and no mechanical fault is present, remove the clutch band (135) and either set it or change it to get the required torque.

34. Tape-out reset plunger and switch, Figs. 12 and 13

Check

- 34.1 With the button (119) and plunger (122) latched down in the 'run' position, check that a gap 'm' of 1/64 in. (.40 mm.) exists between stop screw (120) and transmitter stand (121).

Action

- 34.2 If this is not so, slacken the clamping nut (not shown) of eccentric screw (120) and turn the screw to get the required gap. Re-tighten the lock nut.

Check

- 34.3 With check 33.1 satisfied, open the tape gate so as to unlatch plunger (122).
- 34.4 Insert feeler gauges of 1/64 in. and .015 in. (.40 - .38 mm.) between items (120) and (121). Depress button (119) slowly and check that screw (120) touches the upper gauge before microswitch (123) operates.
- 34.5 Release the plunger and remove the .015 in. gauge. Again slowly depress button (119) and check that switch (123) closes before the screw (120) touches the 1/64 in. feeler gauge.

Action

- 34.6 If these checks are not satisfied, slacken screws (124) to friction tightness and position switch (123) to get the required conditions. Re-tighten the screws.

Note: When the microswitch operates contacts 10 and 11 of the 12-point plug will be short-circuited.

**B. 6S/6-M (MAGNETICALLY-CONTROLLED) MACHINES**

35. Taut-tape switch, Figs. 14 and 15

Check

- 35.1 Insert a 1/4 in. (6.4 mms.) gauge between tape arm (113) and 'stop' bracket (133) and slowly lower the tape arm. Check that the microswitch (128) operates before the arm touches the gauge.

- 35.2 Place a 1/32 in. (.80 mm.) feeler gauge on top of the 1/4 in. gauge and again lower the tape arm. Check that it touches the uppermost gauge before the switch operates.
- 35.3 Put a length of punched tape into the transmitter head, engaging it with the feed sprocket and a pecker. Loop the free end under rollers (134), (138) and over roller (125).
- 35.4 Pull on the free end of the tape, lifting arm (113), until switch (129) operates. Go on pulling and check that the tape can be drawn back two more feed-hole pitches before the tape arm touches the latch spring (126).

**Action**

- 35.5 If either or both these checks are not satisfied, slacken screws (129) and ensure that the switch is lying as low as possible on bracket (130). Re-tighten the screws.
- 35.6 Slacken screws (131) and move bracket (130) to left or right so that the required conditions are obtained. Re-tighten screws (131).
- 35.7 If necessary, re-set cam plate (132) to permit the above adjustment to be done.

**C. 6S/6 (MECHANICALLY-CONTROLLED) MACHINES**

**36. Detent operating lever, Fig. 10**

**Check**

- 36.1 Remove the transmitter head and lower the tape arm (113) against its stop bracket (133). Check that a force of 30 to 50 gms. applied to the end of lever (115) is needed to move it in the direction of the arrow.

**Action**

- 36.2 If this is not so, and no mechanical fault is present, change spring (136).

## VIII. MOTOR AND GOVERNOR INSTRUCTIONS

### A. MAINTAINING THE MOTOR

#### 1. After each 300 hours' working, Fig. 16

1.1 Remove the brush box covers (150), (153) and withdraw the motor springs and brushes, noting the boxes, track and aspects they occupied. If the brushes have a life of less than 400 hours, i.e. if they are less than 3/8 in. (9.5 mms.) long, renew them as follows:-

(a) Slacken the brush-box clamping screws (154), slide out the boxes slightly and slip one end of a strip of fine glasspaper 12 to 18 ins. (30 to 43 cms.) long between the commutator and one of the boxes, with the abrasive surface facing the box. Push in the box until it is just clear of the glasspaper and retighten screws (154).

(b) Fit a new brush and spring in the position of the old one and replace the box cover.

Note: To get the longest life from a new brush, the spring should be renewed at the same time.

(c) Holding the strip of glasspaper tight against the commutator, draw it past the brush in the direction of normal rotation of the motor. Repeat this several times, *in the same direction*, so that the surface of the brush takes up the contour of the commutator. Remove the glasspaper.

(d) Repeat actions (b) and (c) with the other brush box.

(e) Remove the two new brushes, noting the position and aspect of each for replacement in 1.6 below.

1.2 Brush all dust from between the segments of the commutator and remove all surface dust with a clean, dry rag. No attempt should be made to remove the black, glazed surface of the commutator.

1.3 Remove all carbon dust from the base of the governor moulding, between the slip rings and between the inner slip ring and the boss. A soft cloth should be used to prevent damage to the anti-tracking varnish.

1.4 Check the condition of the governor contacts. These should only be touched if they are badly worn or if the correct governed motor speed cannot be obtained. In such cases the contacts should be cleaned and burnished or changed.

Note: If the contacts are cleaned or replaced, adjust as in paragraph 40, section C, of this chapter.

1.5 Adjust the brush boxes as in paragraph 38, section C, of this chapter. Tighten up screws (154).

1.6 Fit the old or new brushes and springs in the same aspect but *in the other* track from which they were withdrawn. Replace the box covers (150), (153).

1.7 Lubricate as instructed in section 2 of chapter IX.

1.8 Run the motor and check its speed as in 41.1 in section C of this chapter. If necessary, take action as in 41.2, section C of this chapter.

2. After each 900 hours' working, Fig. 16

2.1 Carry out instructions 1.1 to 1.7 above.

2.2 Turn the motor by hand and listen for any sign of roughness in the bearings. If any is audible, take action as in paragraph 3 below relating to bearing maintenance.

2.3 Inspect the governor brushes for wear. If necessary, replace them and carry out adjustment 39, section C, of this chapter.

2.4 Lubricate as in section 2 of chapter IX.

3. After each 3600 hours' working, Fig. 16

3.1 Remove the motor from the machine as in section A of chapter V.

3.2 Carry out maintenance instructions in 1.1 above relating to the motor brushes.

3.3 Dismantle the motor as in section B of this chapter.

**Governor**

3.4 Carry out instruction 1.3 above.

3.5 Remove the governor cover and carry out 1.4 and 2.3 above.

**Cleaning**

3.6 Thoroughly dust and clean all parts of the motor except the bearings (see below).

N.B.: Do *not* remove the black glazed surface of the commutator.

**Bearings**

3.7 Soak the bearings in white spirit and remove the old grease.

3.8 Inspect the bearings for wear and end-play between the races. If necessary, obtain replacements and wash them out with white spirit.

3.9 Pack the old or new bearings with Creed No. 4 lubricant - do not use oil.

**Sealing gaskets**

3.10 Inspect gaskets (162), (176), (178), (182). If there are signs of damage, obtain replacements.

3.11 Lightly smear the gasket surfaces with Creed No. 4 lubricant.

## Commutator

3.12 Check the condition of the commutator. If it is pitted or badly worn, proceed as follows:-

- (a) 'Skim up' the commutator in a lathe, using a sharp, pointed tool.
- (b) Check that the mica insulation between the segments is .015 to .025 in. (.38 to .64 mm.) below the surface of the segments.

Note: This may be done by laying a piece of .015 in. gauge wire between the segments. If it protrudes above the surface, the mica needs undercutting.

3.13 To undercut the mica, proceed as follows:-

- (a) Keep the armature in the stationary lathe and shave down all micas with a thin square-edged tool. Cut to a depth of .025 in. (.64 mm.) below the segment surfaces as measured with a piece of wire of that gauge.
- (b) Take a light finishing cut off the commutator as in 3.12(a) above and then remove any burrs which have arisen.
- (c) Polish the commutator with fine glasspaper. Get as high a polish as possible as this keeps down brush wear.

N.B.: Emery cloth and grinding stones should *not* be used.

## Reassembling

3.14 Reassemble the motor as in section B(2) of this chapter.

3.15 Re-fit the motor on the machine as in section B of chapter V.

3.16 Lubricate as in section 4 of chapter IX.

## B. DISMANTLING AND REASSEMBLING THE MOTOR

### 1. Dismantling, Fig. 16

1.1 Slacken the screw (152) securing the drip-proof commutator cover and remove the cover.

1.2 Slide off the brush box covers (150), (153) and extract the brushes.

Note: Note the position and aspect of each brush for reassembling.

1.3 Slacken the four screws (154) securing the brush boxes and slide out the boxes (166), (181), leaving them suspended on their leads.

1.4 Withdraw the two screws holding the fan-end plate (170) to the motor body.

1.5 Extract the three screws (155) which hold the external trefoil clamp plate (160) to the internal clamp ring (165). Remove item (160) and gasket (162).

- 1.6 Using a hide or wooden mallet, gently tap out the armature shaft and bearing (164) from the commutator end plate (163) and withdraw the armature complete with fan-end plate assembly.
- 1.7 Withdraw the three screws (175) holding plate (173) to ring (168).
- 1.8 Remove item (173), gasket (176) and special spring washer (172).
- 1.9 Using the mallet (see 1.6 above) on end (174) of the shaft, tap out bearing (177) from end plate (170).
- 1.10 Slacken the two set screws (169) of lock ring (171) and withdraw the ring.
- 1.11 Using a bearing extractor, draw off bearings (164) and (177).
- 1.12 Remove gaskets (182), (178) and rings (165), (168).
- 1.13 Withdraw the four screws (184) and remove the end plate (163) from the motor body, taking care not to damage the brush box leads while doing so.

## 2. Reassembling, Fig. 16

- 2.1 Lay the gaskets (178), (182) on their respective clamp rings (168), (165), registering the screw holes of each gasket/ring pair. Replace them over the armature shaft.
- 2.2 Replace bearings (164), (177) on their respective ends of the shaft.
- 2.3 Replace lock ring (171), pressing it hard up against bearing (177) before tightening its set screws (169).
- 2.4 Obtain a piece of 6.BA screwed rod about 3 ins. (7.6 cms.) long and engage it a few turns in one of the screw holes of ring (168).
- 2.5 Smear a little Creed No. 4 lubricant on the housing of bearing (177). Hold the armature upright, commutator end downwards.
- 2.6 Lower end plate (170) into position on the shaft, passing the 6.BA rod through one of the screw holes.
- 2.7 Replace washer (172) on bearing (177).
- 2.8 Replace gasket (176) and plate (173), passing the rod through a screw hole.
- 2.9 By means of the screwed rod, lift gasket (178) and ring (168) against end plate (170) and insert two of the screws (175) to hold them in place.
- 2.10 Remove the rod and insert the third screw. Tighten the three screws in turn, a little at a time.
- 2.11 Pass the rod through a screw hole in gasket (182) and screw it a few turns into clamp ring (165).
- 2.12 Replace the armature (179) into the body of the motor and assemble commutator-end plate (163) to the other end of the motor body, passing the 6.BA rod through one of the screw holes.

- 2.13 Enter bearing (164) into its housing and press both end plates into close engagement with the motor body (156), ensuring that the tongues (183) fit into the slots in the motor body.
- 2.14 Secure the two end plates to the motor body with their screws, tightening the latter in turn a little at a time.
- 2.15 Replace gasket (162) and trefoil plate (160), passing a screw hole over the 6.BA rod. Repeat 2.9 and 2.10 at the commutator end of the motor.
- 2.16 Test the armature for free-spinning. If there is any stiffness, tap one end of the shaft with the mallet. If this is not effective, tap the other end.
- 2.17 Reassemble the brush boxes to the recker plate (159), adjusting them in the slots to clear the commutator by .015 in. (.38 mm.), i.e. distance 'n', as measured with a feeler gauge.
- 2.18 Replace the brushes in the same positions and aspects from which they were taken (see 1.2 above).
- 2.19 Replace the drip cover.

### C. MOTOR ADJUSTMENT INSTRUCTIONS

Note: The adjustment serial numbers follow on from section C of chapter VII.

#### 37. Brush rocker, Fig. 16

##### Check

- 37.1 Check that screw (151) is tight and that the positioning marks on the rocker (159) and end plate (163) are in registration.

##### Action

- 37.2 If this is not so, slacken screw (151) and turn the brush rocker to the correct position. Re-tighten screw (151).

#### 38. Brush boxes, Fig. 16

##### Check

- 38.1 Check that the screws (154) are tight. Slide off lids (150), (153) and withdraw the brushes. Check that the clearance 'n' between the brush box and the commutator is .010 to .015 ins. (.25 to .38 mm.).

##### Action

- 38.2 If this is not so, slacken screws (154) and, using a feeler gauge, adjust the brush boxes for a clearance of .015 in. from the commutator.
- 38.3 Remove the feeler gauge, re-tighten screws (154) and replace the brushes in their original positions and aspects.

### 39. Governor brushes

#### Check (for new brushes)

- 39.1 Remove the governor and check that the tip of the back of the governor brush spring is  $3/4$  in. (1.9 cms.) from the motor support plate.
- 39.2 Check also that the governor brush backing spring lies flat against the brush spring.

#### Action

- 39.3 If either of these conditions is absent, set the springs to satisfy them.
- 39.4 Replace and secure the governor, taking care to push it as far on to the shaft as it will go.

#### Check (if the brushes are worn)

- 39.5 Check that a force of  $4\frac{1}{2}$  to  $5\frac{1}{2}$  ozs. (128 to 156 gms.), applied at the tip of the governor springs, is needed to lift the brushes from the slip rings.
- 39.6 If this is not so, remove the governor and set the brush springs to get the required pressure, taking care to push the governor fully on to the shaft for each trial.
- 39.7 Do 39.2 above.

### 40. Governor contacts, Fig. 16

#### Check

- 40.1 Press moving contact (208A) away from fixed contact (208B) so that arm (75) is just touching stop spring (74).
- 40.2 Check that the gap 'p' between the two contacts is .015 to .020 in. (.38 to .51 mm.).

#### Action

- 40.3 If this is not so, slacken screw (73) and adjust contact (208B) to the required gap. Re-tighten screw (73).

Note: When doing 40.3, use the governor adjusting clamp TA.1110 to get the condition in 40.1.

- 40.4 Remove the adjusting clamp.

### 41. Motor speed, Figs. 16, 17, 18

#### Check

- 41.1 Switch on the motor and run the transmitter. Using the 125 dv/S fork strobe, check that the motor speed is correct, i.e. that the white stripes on the governor cover seem to be stationary.

Note: If the stripes seem to drift in the direction of the motor rotation, the speed is too high. If they drift the other way the speed is too low.

**Action**

41.2 If the speed is incorrect, take the following actions in the order given until the correct speed is obtained.

- (a) Check the supply voltage.
- (b) Latch up the tape arm to stop the transmitter and short the governor brush springs. There should be a marked increase in motor speed.
- (c) Switch off the motor, remove the short, take off the governor and switch on again. There should be a marked decrease in motor speed.
- (d) If (b) and (c) are not satisfactory, test the governor circuit (see chapter XI on circuitry and Figs. 17 and 18).
- (e) Adjust the governor setting by turning screw (72) clockwise (viewed from above) to increase the governed speed and vice versa.

Note: To do (e) use a narrow-bladed screwdriver on the head of screw (72) through the hole in the rim of the governor cover.

## IX. LUBRICATING INSTRUCTIONS

1. The following lubricants are recommended and may be obtained from Creed and Company Ltd.:-

No. 2 Lubricant - medium oil, such as:-

- (a) Talpa Oil 30 (Shell Oil C.T.2).
- (b) Wakefield Castrol XL.
- (c) G.P.O. Oil No. 14.

No. 4 Lubricant - grease, such as:-

- (d) Shell Nerita grease 3 (Shell VW).

No. 5 Lubricant - grease, such as:-

- (e) Mobilgrease No. 2.

2. After each 300 hours' working:-

No. 2 oil: Apply a small quantity to the following points, taking care that none gets on the contacts:-

Transmitter head, Fig. 1 and Plate 4

- (a) Jockey roller and pivot (305), Plate 4.
- (b) Tip of striker cam foller (39), Fig. 1.
- (c) Striker dart guides (27), Fig. 1.
- (d) Rubbing surfaces between striker dart and its operating arm (303), Plate 4.
- (e) Rubbing surfaces between common selector lever (22), Fig. 1, and stop plate (30).

Tape control unit Plate 6

- (f) Retention lever cam track (319).
- (g) Pivot of tape arm (316).
- (h) Pivot of retention lever (317).
- (j) Retention roller (318).

No. 5 grease:

- (a) Apply a little to the motor pinion and gear wheel (314), Plate 6.
- (b) Smear a little on the striker dart (27), Fig. 1, and tongue (37) knife edges.

3. After each 900 hours' working:-

Carry out 2 above.

No. 2 oil: Apply a small quantity to the following points, taking care that none gets on to the contacts:-

Front of transmitter head, Plate 4

- (a) End bearing of transmitting cam spindle (308).
- (b) Pecker lever pivot bar (307).

- (c) Pecker lever guide plate (306).
- (d) Common selector lever pivot (301).
- (e) Transmitter tongue pivot (304).
- (f) Striker lever pivot (302).
- (g) Tape-seeker lever pivot (300).

Rear of transmitter head, Plate 5

- (h) Retention roller pivot (310).
- (j) Feed pawl pivot (313).
- (k) Retention and feed lever pivot (312).

4. On dismantling after each 3,600 hours' working

Carry out 2 and 3 above.

No. 2 oil, Plates 4, 5 and 6:

- (a) Apply a little to all rubbing surfaces (except contacts) not dealt with in 2 and 3.
- (b) Apply a few drops to the two oil holes in the top of the transmitter head.

Note: These oil holes feed the Oilite bearing bushes of the transmitter cam and the tape-feed sprocket.

- (c) Saturate the lubricating pads of the transmitter cam (309) and the tape-feed cam (311).
- (d) Saturate the clutch sleeve lubricating ring (315).

No. 4 grease:

- (a) Lubricate the motor bearings as in 3.7 to 3.9 of section A, chapter VIII.

No. 5 grease, Fig. 3:

- (a) Smear both sides of the loose coupling disc (83).

## X. SPRINGS

SPRING FOR	FIG. REF. NO.	PART NO.	DETAILS
Tape Gate latch	1       -	1550/382	-
'Gate-open' trip arm	1       (20)	PG.5147	Compression spring. See adjustment 18.
Adjustable tape guide pin	1       (16)	1550/679	'S' leaf spring
Tape-seeker	(not shown)	PG.7070	Force needed to extend spring from 15/32 to 29/32 in. (11.9 to 23.0 mms.) is 3 to 3½ ozs. (85 to 99 gms.).
Tape-seeker lever	(not shown)	PG.7208	Force needed to extend spring from 1/2 to 37/64 in. (12.7 to 14.7 mms.) is 2¼ to 2½ ozs. (64 to 71 gms.). See adjustment 15.
Common selector lever	1       (25)	PG.7374	Force needed to extend spring from 5/8 to 7/8 in. (15.9 to 22.2 mms) is 8 to 10 ozs. (227 to 284 gms.). See adjustment 9.
Striker lever	1       -do-	-do-	-do-       -do- See adjustment 14
Jockey lever	1       (36)	PG.7377	Force needed to extend spring from 19/64 to 9/16 in. (7.5 to 14.3 mms.) is 4 to 4¼ lbs. (1.812 to 2.152 Kgs.). See adjustment 13.
Pecker levers	(not shown)	PG.7376	Force needed to extend spring from 11/16 to 13/16 in. (17.5 to 20.6 mms.) is 581 to 751 gms.
Tape feed retention lever	2       (65)	PG.7226	Force needed to extend spring from 23/32 to 1 in. (18.3 to 25.4 mms.) is 26 to 30 ozs. (738 to 850 gms.).

SPRING FOR	FIG. REF. NO.	PART NO.	DETAILS
Feed pawl lever	2 (66)	PG.7196A	Force needed to extend spring from 23/32 to 1-1/32 ins. (18.3 to 26.2 mms.) is 7¼ to 8¾ ozs. (220 to 248 gms.)
Feed pawl	2 (68)	PG.7054	Force needed to extend spring from 19/32 to 1-17/32 ins. (15.1 to 38.9 mms.) is 4 to 4½ ozs. (113 to 128 gms.)
Tape-out latch lever	2 (70)	PG.7100	Force needed to extend spring from 5/8 to 27/32 in. (15.9 to 21.4 mms.) is 2½ to 4 ozs. (71 to 113 gms.). See adjustment 16.
Tape-out latch control lever	2 (47)	PG.7176	Force needed to extend spring from 15/32 to 29/32 in. (11.9 to 23.0 mms.) is 2 to 2½ ozs. (57 to 71 gms.). See adjustment 17.
Electromagnet armature	6 (98)	PG.7300	Force needed to extend spring from 1-7/16 to 1-13/16 ins. (36.5 to 46 mms.) is 5½ to 6½ ozs. (156 to 187 gms.). See adjustment 27.
Tape arm	8 (112)	PG.7100	Same as item (70) above. See adjustment 31.
Clutch retention lever	8 (105)	PG.7457	Force needed to extend spring from 1 to 1-3/8 in. (25.4 to 34.9 mms.) is 3 to 4¼ lbs. (1.359 to 1.925 Kgs.). See adjustment 22.
Clutch detent arm	8 (100)	PG.3110	Force needed to pinch arms of spring to an angle of 45° is 30 to 50 gms. See adjustment 28.
Clutch pawls	(not shown)	PG.3022B	See adjustment 24.
Tape-arm latch	14 (126)	1550/671	-

SPRING FOR	FIG. REF. NO.	PART NO.	DETAILS
Detent operating arm	10 (136)	PG.7075	Force needed to extend spring from 43/64 to 1-1/8 ins. (17.1 to 28.6 mms.) is 1 3/4 to 2 1/4 ozs. (50 to 64 gms.).
Take feed cam oil pad	2 (54)	PG.7373	-

## XI. CIRCUITRY

- Note:
- (i) The use of Figs. 17 and 18 together makes it possible to trace and check the internal circuits of the machine. Figs. 1, 8, 9, 13, 15 and 16 and Plate 3 also show electrical components.
  - (ii) In Fig. 17, the junction of a straight and a curved (or two curved) wires points towards their common connecting point. Thus the leads from terminals 3 of (209) and 2 of (201) meet at terminal 6 of (202) and the leads from terminals 1 of (205) and 1 of (203) meet at terminal 3 of (202).
  - (iii) The information on the signal circuit is based on the use of the standard 12-way plug (190) as illustrated.

### 1. Signal plug, Fig. 17

- 1.1 Tags 1, 2 and 3 cater for the transmitting contacts assembly (33) with its suppressors (191), (192) and (194) and its limiting resistor (196). The final leads to the contact block (194) are from terminals 4, 5 and 8 of block (197). The three 5 uH., 1A. inductors are sealed in these final leads.
- 1.2 Tags 4, 5 and 6 serve the send-receive switch (103) - if fitted - with its suppressors (191), (193) and (222). The final leads to the switch are from terminals 1, 2 and 3 of block (197). The three 5 uH., 1A. inductors (222) are sealed in these final leads.
- 1.3 Tags 7, 8 and 9 are connected to the clutch relay (140) and the taut-tape microswitch (128). When the tape is becoming strained, it lifts arm (134), Fig. 15, and mechanically operates microswitch (128). This conducts current to the clutch magnet (140) which operates, arrests the clutch sleeve and stops the transmitter.
- 1.4 Tags 10, 11 and 12 go to the 'tape-out' microswitch (123) which is mechanically operated by the 'tape-out' and 'gate-open' levers in the transmitter. By external connections the switch can be used either to work the clutch magnet and stop the transmitter or to give a warning indication of the 'tape-out' or 'gate-open' condition.

### 2. Motor and governor circuit, Fig. 17

- 2.1 Links (210) or (211) are set to suit the type and voltage of the mains supply. The mains are then connected to plug (200).

Note: Link (211) is the two links (210) in parallel.

- 2.2 When switch (205) is closed, the mains voltage is applied to the motor via resistors (198) and governor contacts (208). The motor quickly runs up to its required speed.
- 2.3 Any further increase in speed causes governor contacts (208) to open and brings resistor (204) into circuit. This reduces the speed and the contacts close again.
- 2.4 The repeated opening and closing of the governor contacts keeps the r.p.m. around the required value. Capacitor (199) helps to quench sparking at the contacts.

- 2.5 Filter unit (201), inductors (207) and capacitor unit (209) provide effective radio and TV interference suppression.

Note: The mains filter unit (201) is a sealed inductor-capacitor network. It should show high conductivity between terminals 1 and 2 and between terminals 5 and 5. There should be high insulation resistance between terminals 1, 2 and 5, 6 and between 1, 2, 5, 6 and 3, 4.

If the unit is judged to be faulty, it should be changed.

- 2.6 If there is an external mains switch and the motor is to be run for long periods, internal switch (205) may be shorted out by link (202).

## XII LIST OF ITEMS ILLUSTRATED

Note: This list enables every numbered item to be immediately identified and indicates all illustrations in which it appears.

Item No.	Figure (F) and Plate (P) Nos.	Name
1	F.1	Pecker guide plate
2	"	Tape-gate latch plate
3	"	Pecker-spring anchor block
4	"	Tape guide plate
5	"	Tape gate latch
6	"	" " " pivot screw
7	"	" " " pin
8	"	" " adjusting screw
9	"	'Gate-open' arm adjusting screw
10	"	Latch-stop clamping screw
11	"	" " plate
12	"	'Gate-open' trip block guide screw
13	"	Pecker guide plate support block
14	"	Tape-gate assembly
15	"	Tape-gate hinge nut and washer
16	"	Tape-guide pin 'S' spring
17	"	Adjustable tape-guide pin
18	"	" " " " " nut and washers
19	F.1, P.4	'Gate-open' trip block and arm
20	" "	" " " " " spring
21	F.1	Tape-seeker lever
22	"	Common selector lever assembly
23	"	Start-stop lever
24	"	Striker lever assembly
25	"	Common selector lever return spring
26	"	Striker lever return spring
27	"	Transmitter striker dart
28	"	Slot in selector lever assembly
29	"	Jockey roller arm
30	"	Common selector lever stop plate
31	"	" " " " " " screw
32	"	Jockey arm pivot
33	F.1, 17, 18	Transmitter contact block CP
34	F.1	Transmitter head front cover guide
35	"	'Mark' contact screw
36	"	Jockey lever spring
37	"	Transmitter tongue
38	"	'Space' contact screw
39	"	Striker lever cam follower
40	"	Pecker lever guide
41	"	Striker arm plate adjusting screw
42	"	Pecker lever
43	"	Pecker levers retaining clip
44	"	Transmitting cam
45	"	Camshaft bearing plate
46	"	Pecker spring adjusting screw
47	F.2	'Tape-out' latch lever spring

Item No.	Figure (F) and Plate (P) Nos.	Name
48	"	Tape-feed pawl
49	"	'Tape-out( plunger operating lever
50	"	Tape-feed retention lever
51	"	Tape-feed ratchet wheel clamping screw
52	"	Tape-feed ratchet wheel
53	"	Tape-feed cam
54	"	Feed cam lubricator spring
55	"	Front cover guide fixing screw
56	"	Feed cam lubricator collar
57	"	Feed cam lubricator
58	"	Tape-feed cam follower
59	"	Tape-feed pawl adjusting screw
60	"	Tape-feed levers collar
61	"	Transmitting contacts block securing screws
62	"	See item (55)
63	"	" " "
64	"	Tape-feed pawl lever
65	"	Tape-feed retention lever spring
66	"	" " pawl lever spring
67	"	See item (55)
68	"	Tape-feed pawl spring
69	"	'Tape-out' latch lever
70	"	" " plunger lever spring
71	F.6	Electromagnet armature
72	F.16	Governor adjusting screw
73	"	" fixed contact lock screw
74	"	" moving contact stop spring
75	"	" " " arm
76	"	" spring
77	F.3,4,7,9,10,11	Clutch sleeve
78	F.3	Clutch spindle bearing block
79	"	" fixing screw
80	"	" bearing boss
81	F.3, P.2	" gear wheel
82	F.3	Control unit casting
83	F.3, P.2	Nylon coupling disc
84	F.3	Transmitter coupling dog
85	F.4, 9	Clutch retention roller
86	F.4,6,7,10,11	" detent lever
87	F.4	" retention arm pivot clamping screw and pellet
88	"	" " " eccentric pivot
89	F.7,10,11	" pawls
90	-	- - -
91	F.6,10,11	Detent lever stop pin
92	F.6	Electromagnet fixing screws
93	"	" armature roller
94	F.7, 10	Screw-in spring anchor
95	" "	Electromagnet mounting plate fixing screw
96	" "	" mounting plate
97	F.5	Clutch driving arm
98	F.6	Electromagnet armature spring
99	F.8,9	Clutch retention roller recess

Item No.	Figure (F) and Plate (P) Nos.	Name
100	F. 8	Clutch detent lever spring
101	F.9	Send-receive switch mounting plate fixing screws
102	"	" " " contact lock nut
103	F.9,17,18	" " " mounting plate
104	F.9	" " " 'receive' contact
105	"	Clutch retention arm spring
106	"	Send-receive switch tongue
107	"	" " " 'send' contact
108	"	See item (101)
109	"	" "a (102)
110	F.5	Shims between driving arm and gear wheel
111	F.4	Clutch retention roller arm
112	F.7,8, 10	Tape-arm return spring
113	F.8,10,11,14,15	Tape arm
114	F.11	Detent operating roller eccentric pivot
115	F.10,11	" " arm
116	F.11	" retention collar set screw
117	"	" " "
118	F.8,11,15	Tape arm pivot bar
119	F.12	'Tape-out' re-set button
120	"	" plunger arm eccentric stop screw
121	F.12, P.1	Transmitter stand
122	F.12	'Tape-out' plunger arm
123	F.13,17,18	" " microswitch
124	F.13	" " " fixing screws
125	F.14	Bracket-mounted tape roller
126	"	Tape-arm latch spring
127	F.15	" " pivot bar locknut
128	F.8,15,17,18	Taut-tape microswitch
129	F.8, 15	" fixing screws
130	" "	" mounting plate
131	" "	" " " fixing screws
132	" "	Tape arm cam plate
133	F.10,14,15	Tape roller and latch spring bracket
134	F.15	Tape arm roller (inside)
135	F.5	Clutch band
136	F.10	Spring for detent-operating arm
137	F.15	Tape arm roller pivot nut
138	"	" " " (outside)
139	"	Flange of bracket tape roller
140	F.8,17,18	Electromagnet
141	F.13, 17,18	'Tape-out' plunger stop screw nut
142	F.2	Tape-feed cam set screw
143	F.6, 11	Detent lever retaining clip
144	F.5	Driving arm clamp screw
145	F.3	Clutch oiling washer (felt)
146	"	Clutch spindle bearing boss
147	F.7	Clutch sleeve retaining screw
148	F.10	Tape arm retaining clip
149	-	- - -
150	F.16	Brush box cover
151	"	Brush rocker clamp screw

Item No.	Figure (F) and Plate (P) Nos.	Name
152	F.16	Commutator cover screw
153	"	See item (150)
154	"	Brush box fixing screws
155	"	Bearing clamp plate screws
156	"	Motor Body
157	"	Brush rocker guide pins
158	"	Motor connecting plug
159	"	Brush rocker
160	"	Bearing clamp plate (external)
161	F.16,17,18	Field strapping block
162	F.16	Small gasket
163	"	Commutator-end plate
164	"	" " bearing
165	"	" " clamp plate (internal)
166	"	Brush box
167	"	Fan
168	"	See item (165)
169	"	Lock ring grub screw (2 off)
170	"	Fan-end plate
171	"	Bearing lock ring
172	"	Special spring washer
173	"	See item (160)
174	"	Armature shaft
175	"	See item (155)
176	"	" " (162)
177	"	Fan-end bearing
178	"	Large gasket
179	"	Armature
180	F.16,17,18	Commutator
181	F.16	See item (166)
182	"	Large gasket
183	"	Tongue on commutator end plate
184	"	Commutator end plate securing screw
185)		
to	-	- - -
188)		
189	F.17,18	Capacitor, 0.1 uF.
190	F.17,18, P.2,3	12-point signal plug
191	F.17,18	Transmitter suppressor unit (6 x 0.5H)
192	F.17,18, P.3	Transmitter capacitor unit
193	F.17,18	Send-receive switch capacitor unit
194	" "	Transmitter stand contact plate (3 x 5 uH, RF, 1A.)
195	" "	Link (wire)
196	F.17,18, P.3	Resistor, 220 ohms
197	" " "	8-way terminal block
198	" " "	Governor RIS resistors (2 x 6.8 ohms)
199	" " "	" " capacitor (0.1 uF.)
200	" " "	4-point power plug
201	" " "	Mains filter unit
202	F.17,18	Motor connecting block
203	" "	Fuse (0.35A.)
204	" "	Motor series resistor (2,000 ohms)

Item No.	Figure (F) and Plate (P) Nos.	Name
205	F.17,18, P.3	Motor ON/OFF switch
206	F.17,18	Motor unit
207	" "	Inductors RIS (2 x 5 uH, RF, 2A.)
208	F.16,17,18	Governor contacts
209	F.17,18, P.3	Delta RIS capacitor unit (total 470 pF)
210	F.17,18	Motor field links (200-250 AC, 160 DC)
211	" "	" " link (200-250 DC)
(Note: Item (211) is made up of both items (210))		
212)		
to	-	- - -
214)		
215	P.1	Transmitter head clamping screw
216	"	" " front cover
217	"	Machine cover
218	"	Base cover plate
219	"	Transmitter stand fixing screw
220	"	" head
221	P.2	" rear cover plate
222	F.17,18, P.2	Send-receive switch leads (including RIS inductors)
223	P.2	Motor end-plate clamp screw
224	"	Motor
225	-	- - -
226	P.2	See item (223)
227	-	- - -
228	P.2	Motor end plate fixing screw
229	-	- - -
230	P.2	Governor brush block cover
231	"	Motor end plate mounting block
232	F.17,18	Motor brushes
233	F.17,18, P.2	Governor brushes
237	F.16,17,18, P.2	Governor
<b>Lubricating Points</b>		
300	P.4	Pivot of tape-seeker lever
301	"	" " common selector lever
302	"	" " striker lever
303	"	Rubbing faces of striker dart and operating arm
304	"	Pivot of transmitting tongue
305	"	Jockey roller and pivot
306	"	Pecker lever guide plate
307	"	Pivot bar of pecker levers
308	"	Front end bearing of transmitter cam spindle
309	"	Transmitting cam oiling pad
310	P.5	Pivot of retention roller
311	"	Feed cam oiling pad
312	"	Pivot of retention and feed levers
313	"	" " feed pawl
314	P.6	Gear wheel
315	"	Clutch sleeve lubricating ring
316	"	Pivot bar of tape arm
317	"	Pivot of retention lever
318	"	Retention roller
319	"	Retention lever cam track

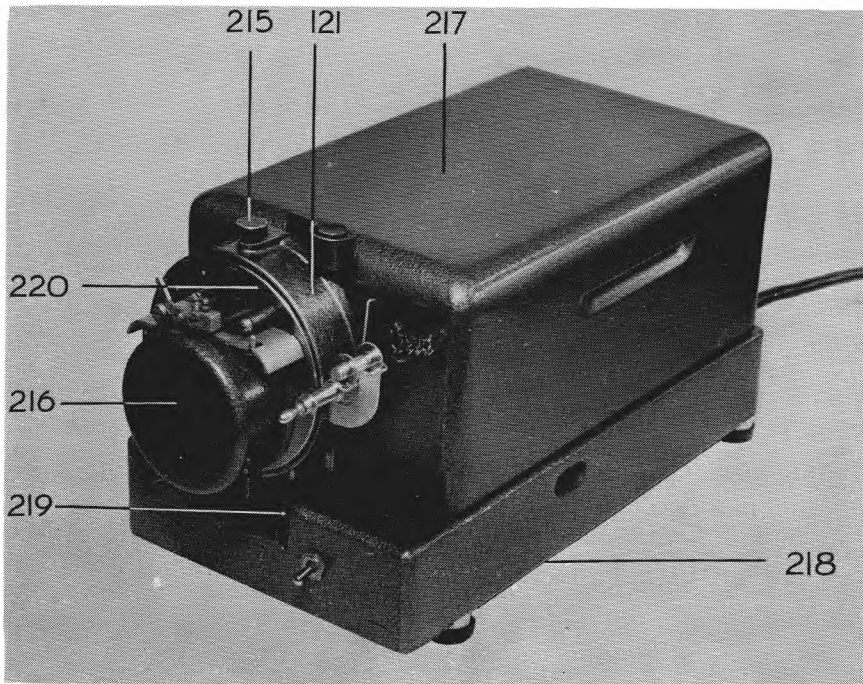

PLATE 1 MODEL 6S/6-M AUTOMATIC TRANSMITTER

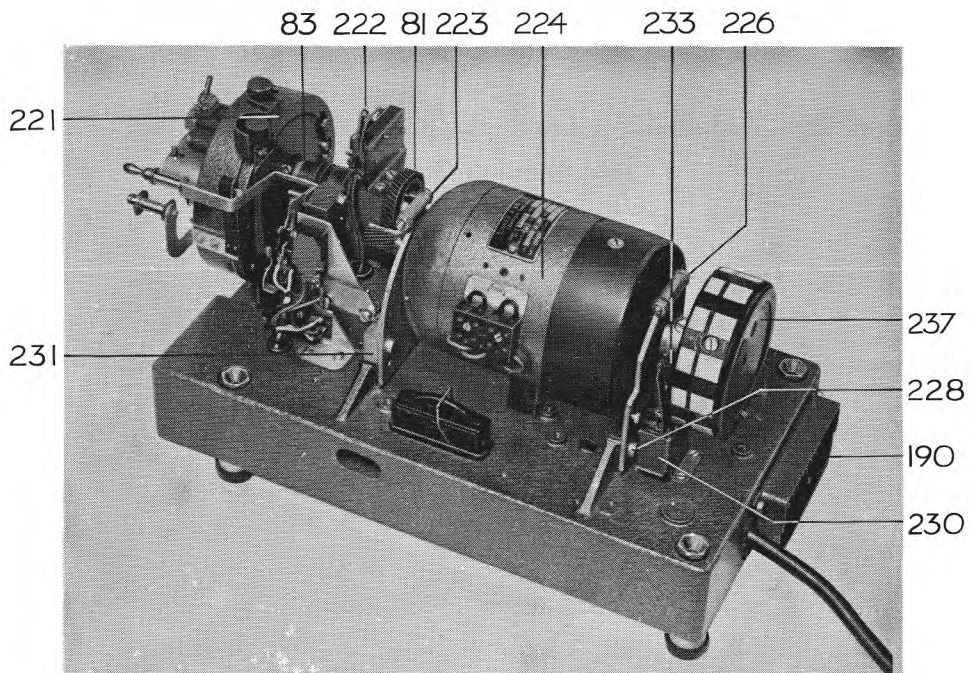

PLATE 2 MODEL 6S/6-M, COVER REMOVED

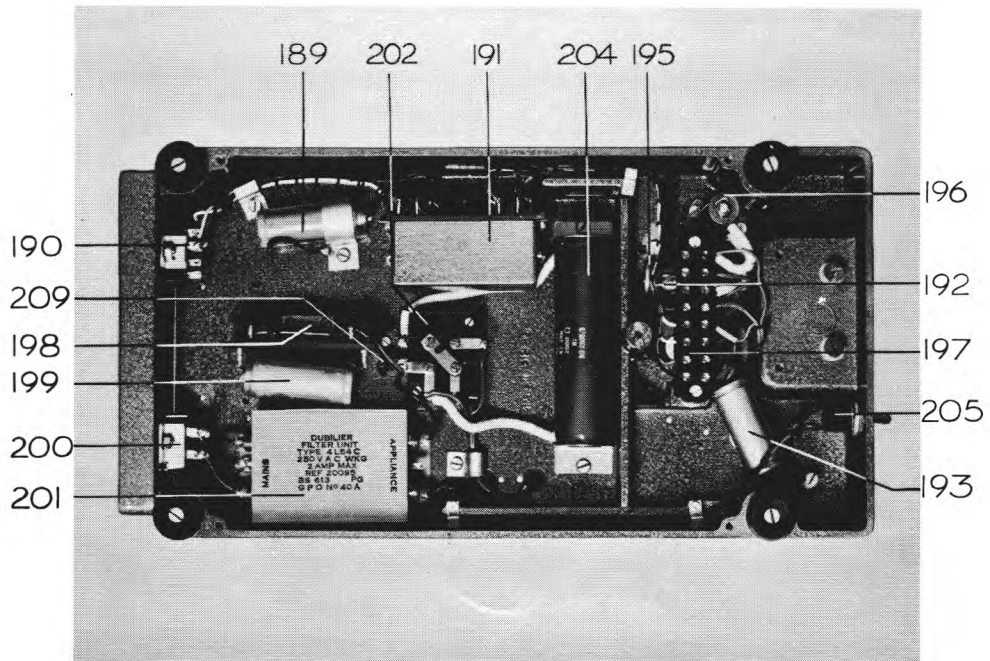

PLATE 3 MODEL 6S/6-M, UNDER-VIEW  
(BASE COVER OFF)

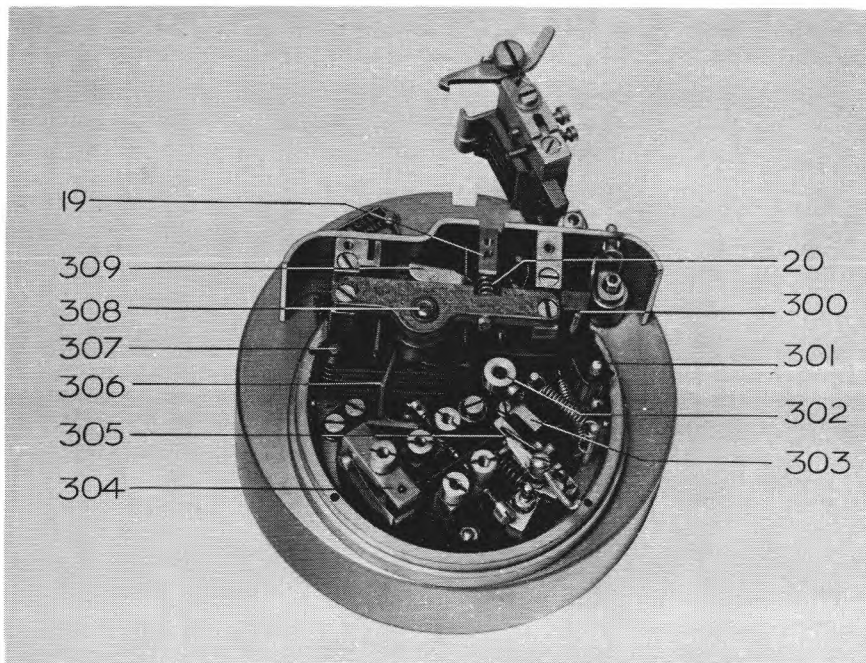

PLATE 4 TRANSMITTER HEAD, FRONT  
COVER REMOVED

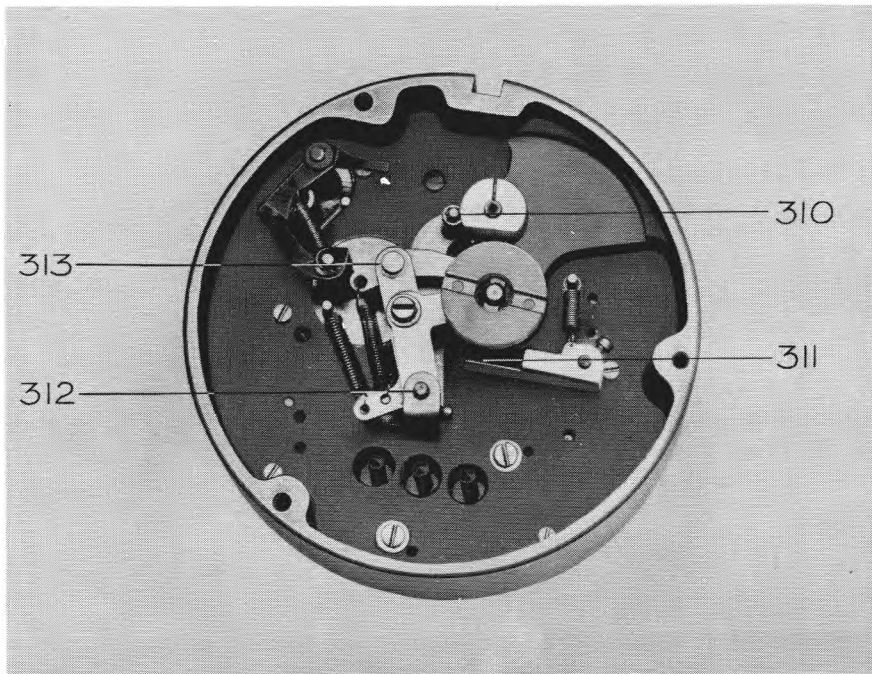

PLATE 5 TRANSMITTER HEAD, REAR  
COVER REMOVED

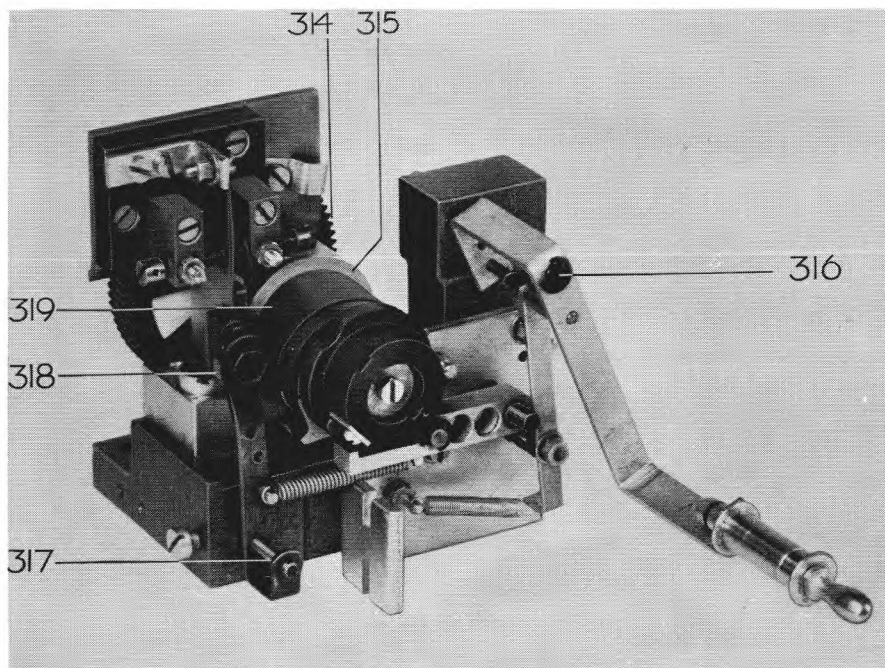

PLATE 6 MODEL 6S/6 CONTROL UNIT

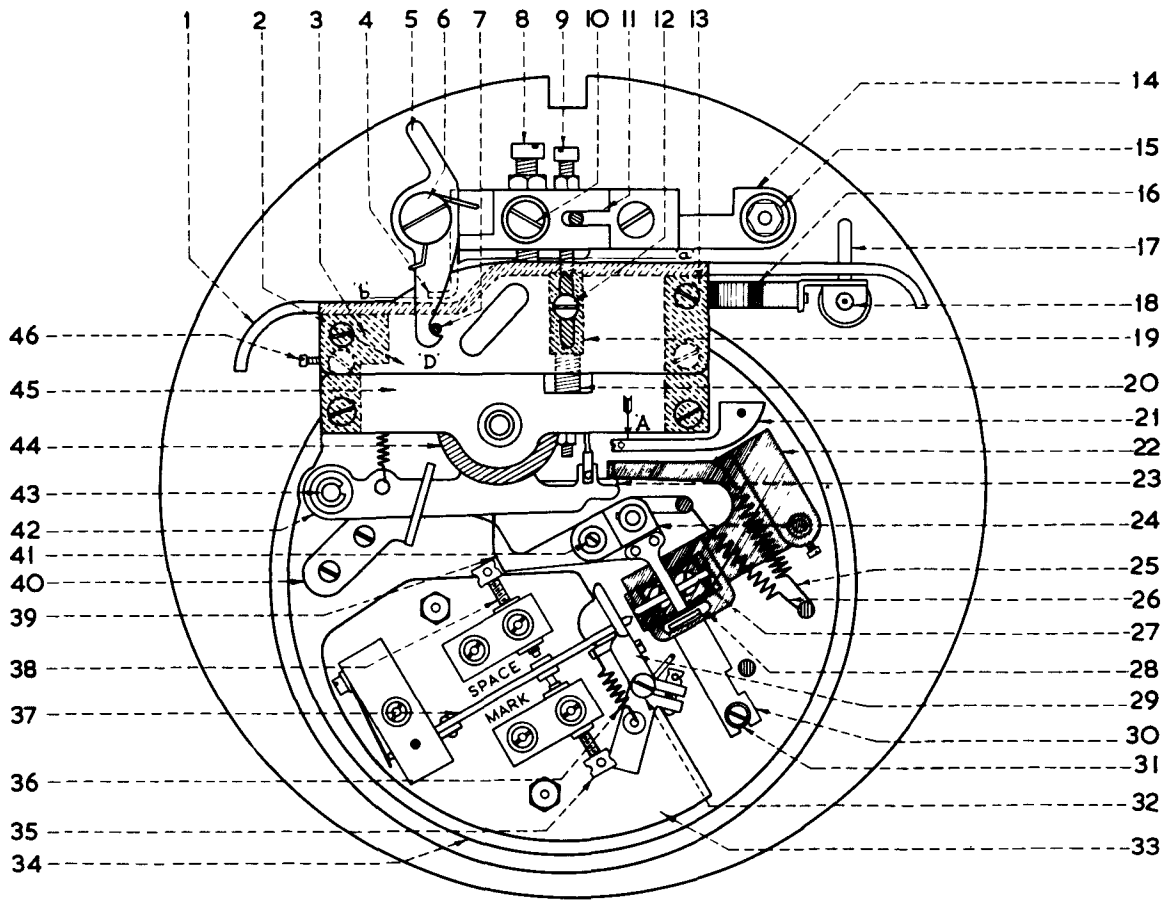

FIG. I TRANSMITTER HEAD, FRONT VIEW

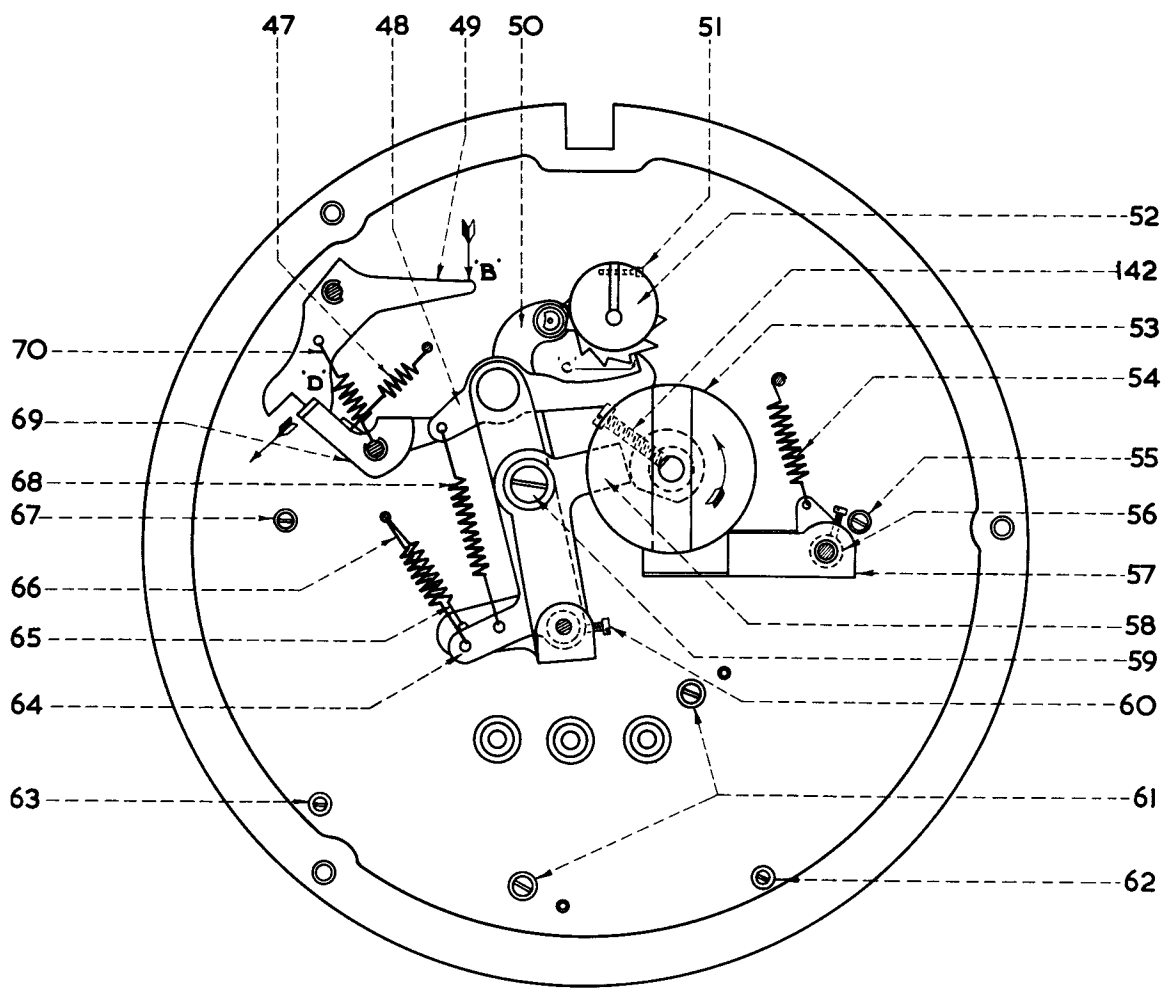

FIG. 2 TRANSMITTER HEAD, REAR VIEW

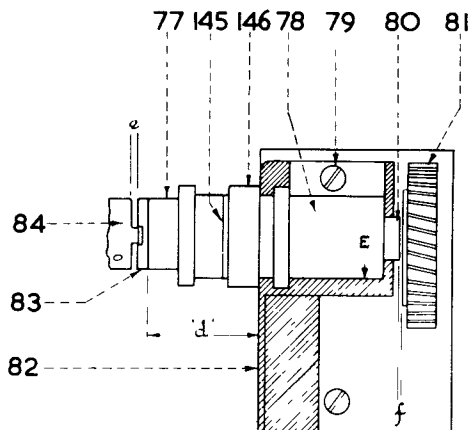

FIG. 3

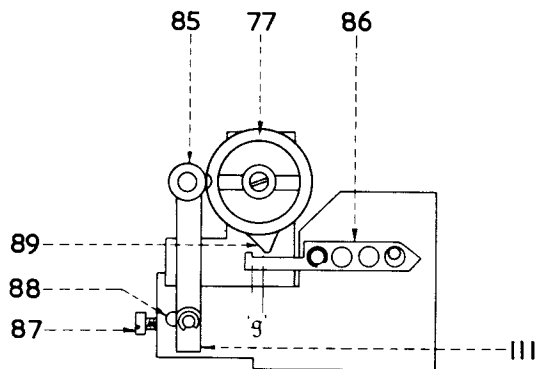

FIG. 4

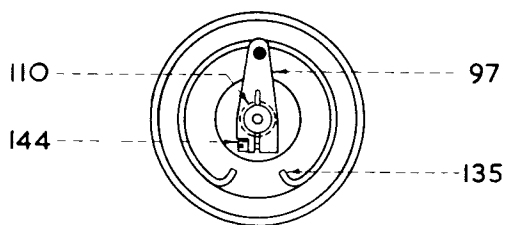

FIG. 5

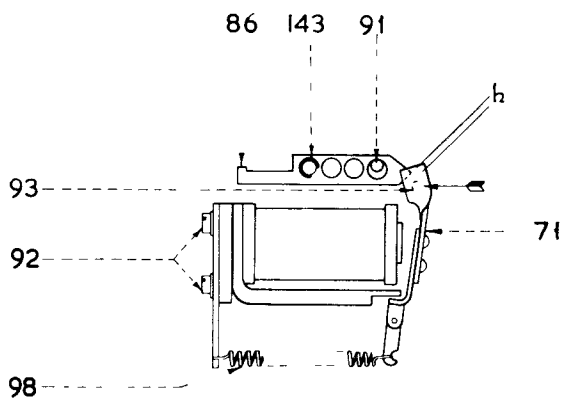

FIG. 6

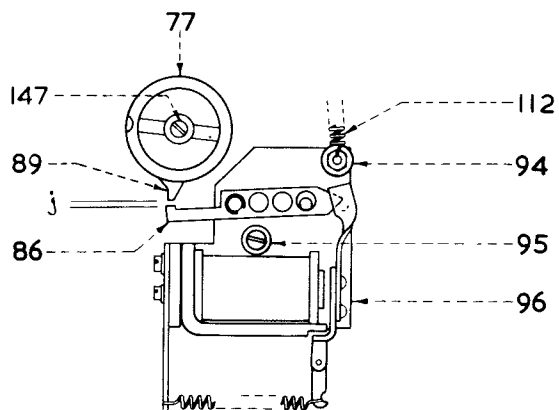

FIG. 7

6S/6 & 6S/6 M TAPE CONTROL UNIT ADJUSTMENTS

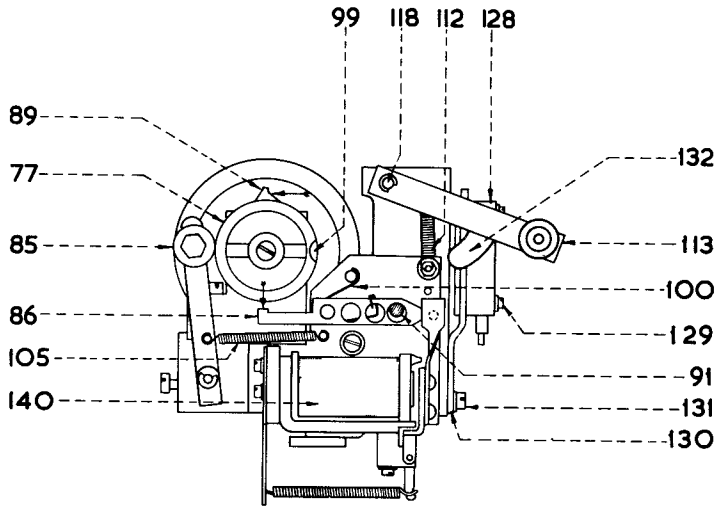

FIG. 8

TAPE CONTROL UNIT

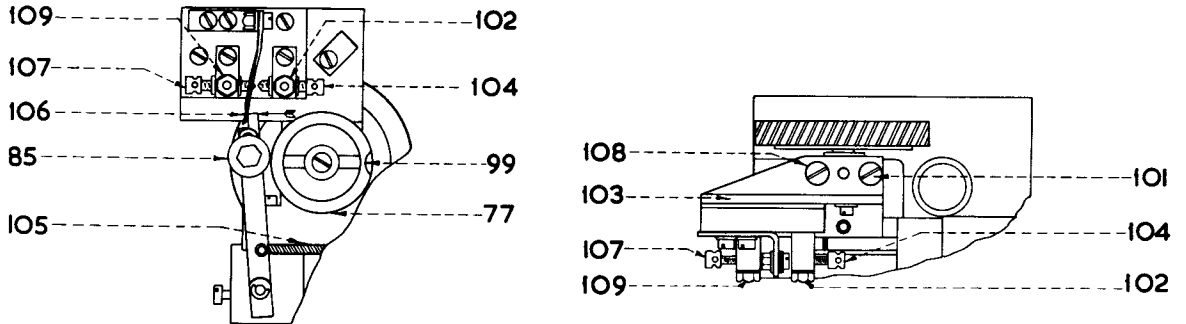

FIG. 9

SEND-RECEIVE SWITCH

MODEL 6S/6 M AUTO TRANSMITTER

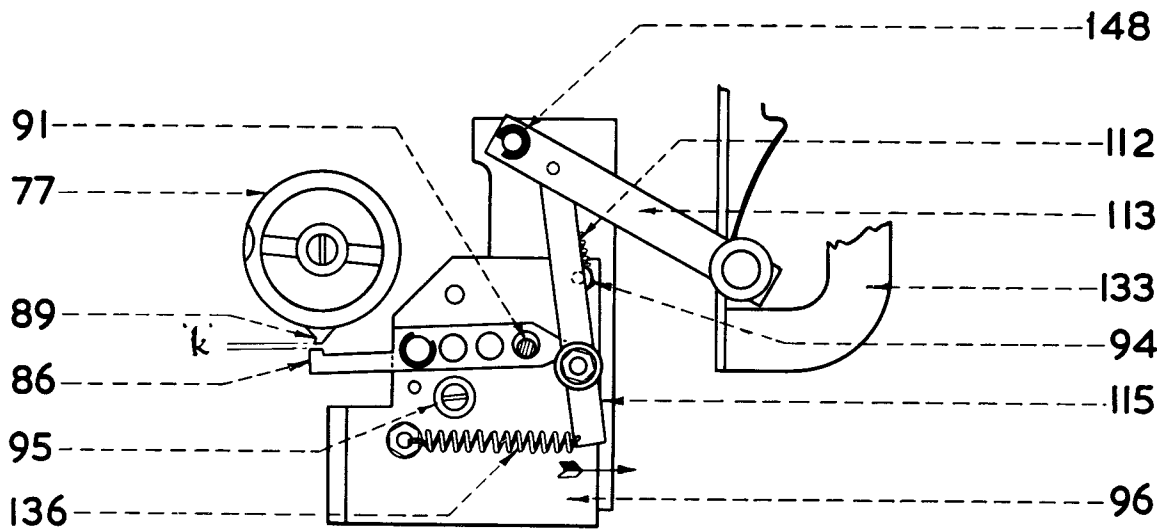

FIG. 10

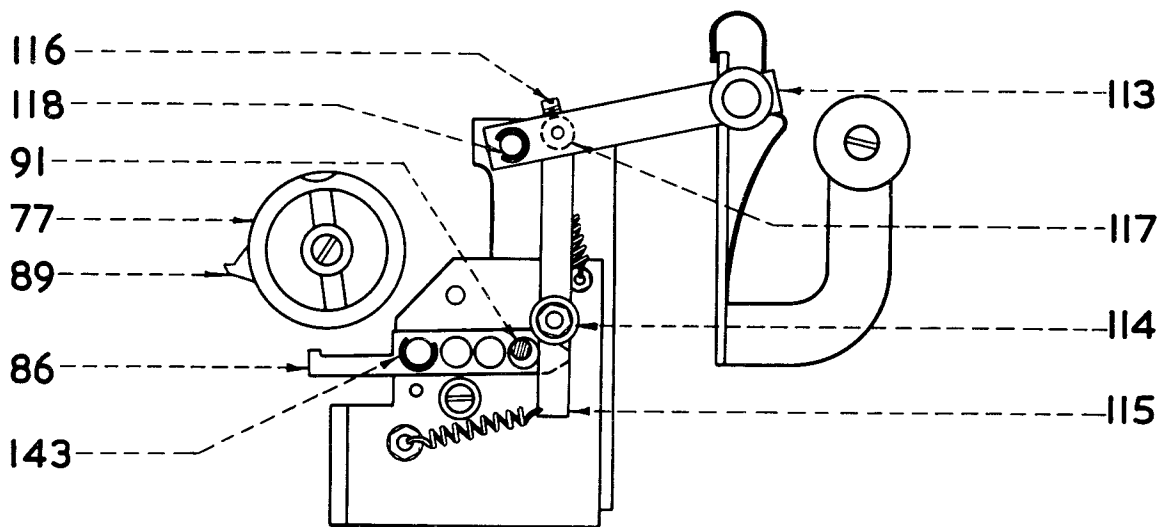

FIG. 11

6S/6 TAPE CONTROL UNIT ADJUSTMENTS

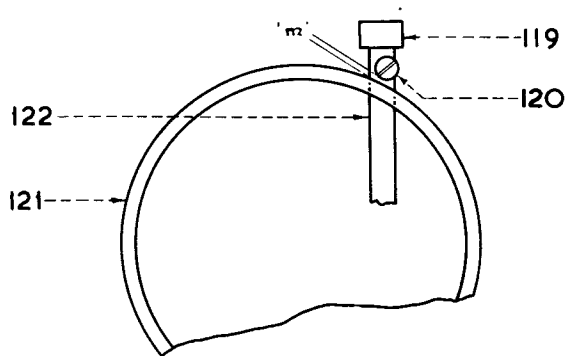

FIG. 12

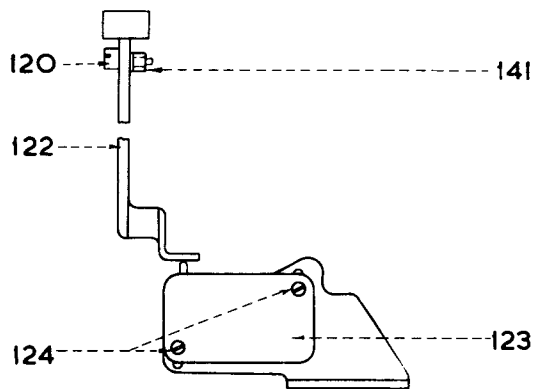

FIG. 13

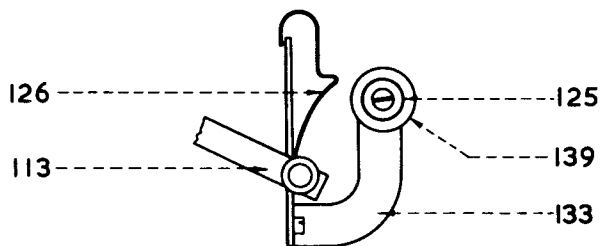

FIG. 14

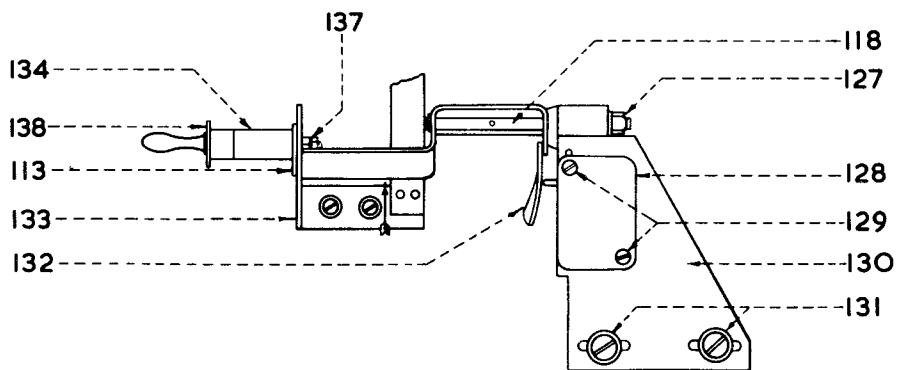

FIG. 15

6S/6 & 6S/M MACHINE ADJUSTMENTS

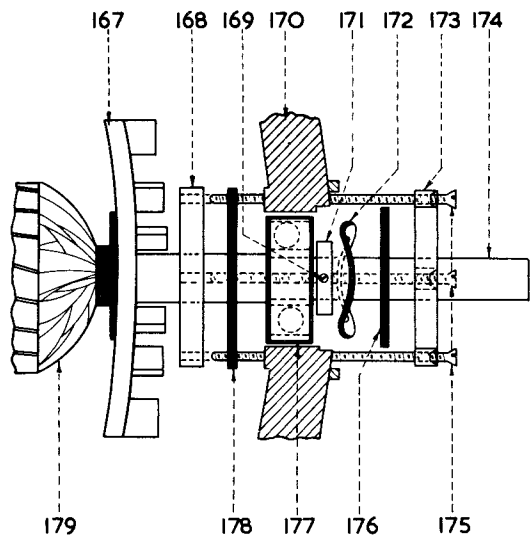
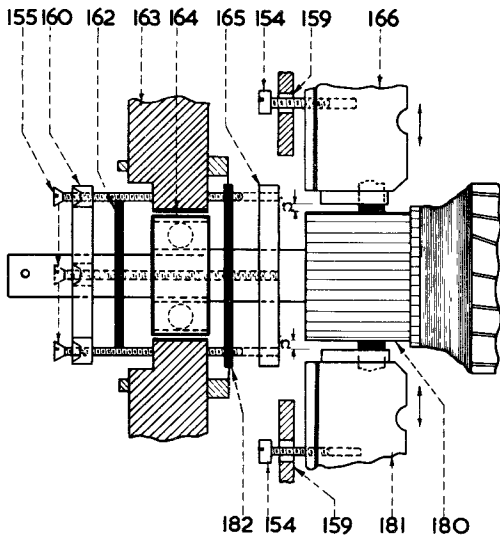
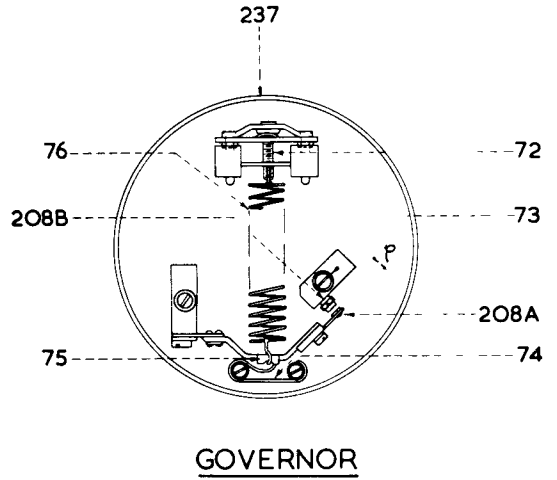
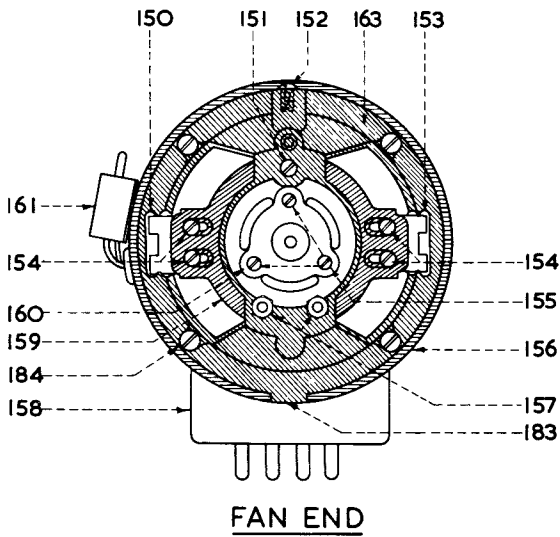
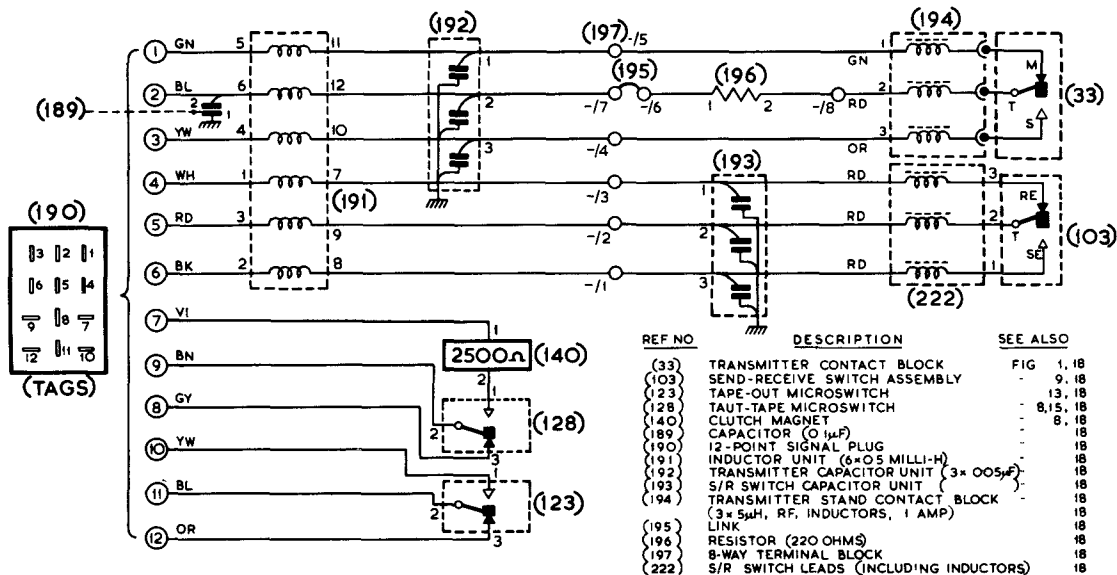
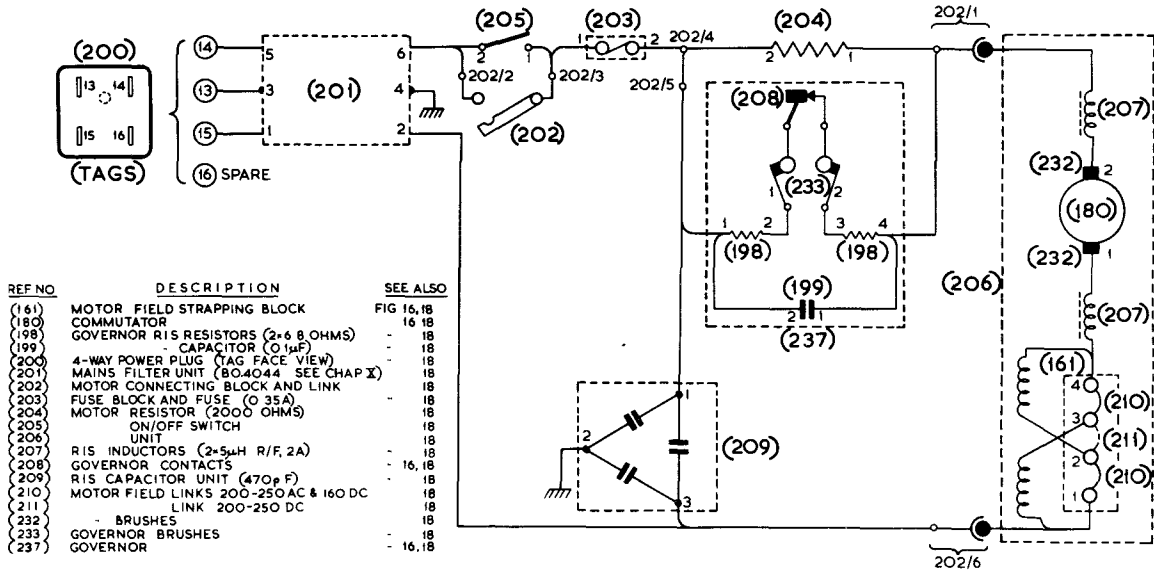

FIG. 16 MODELS 6S/6 & S/6 M MOTOR DIAGRAMS



### A SIGNAL CIRCUIT SCHEMATIC

(NOTE FOR CIRCUIT TRACING & FAULT FINDING THESE DIAGRAMS SHOULD BE USED WITH THOSE IN FIG 18)



### B. MOTOR CIRCUIT SCHEMATIC

FIG. 17 6S/6 & 6S/6-M CIRCUIT SCHEMATICS

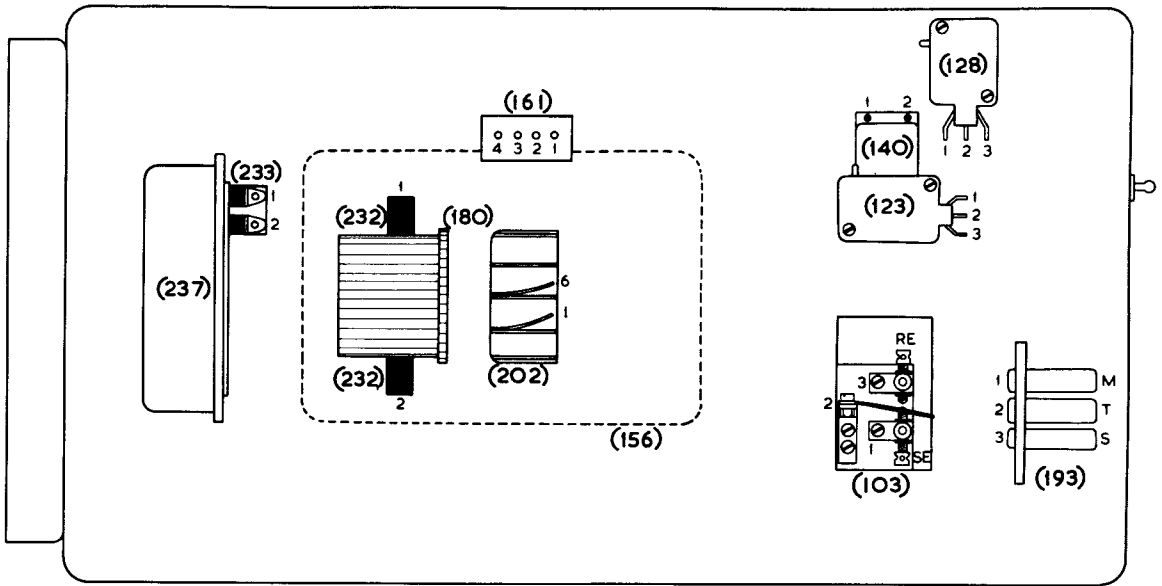

TOP

(NOTE: FOR CIRCUIT TRACING & FAULT FINDING THESE DIAGRAMS SHOULD BE USED WITH THOSE IN FIG 17)

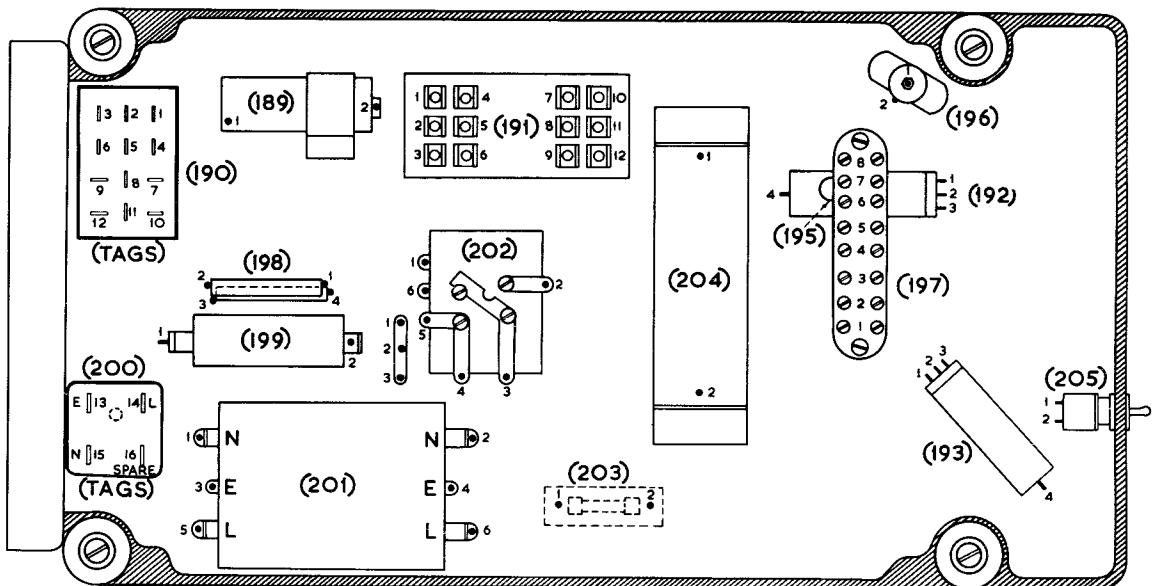

BOTTOM

FIG. 18 6S/6-M ELECTRICAL COMPONENTS  
(FOR KEY SEE FIG. 17)

**AMENDMENTS TO INSTRUCTION BOOK No.33 (10th Ed.)**

**Note:** This Technical Information Supplement deals with amendments to the above book to cover the 75-baud (100 w.p.m.) version of the Model 6S/6 Auto-Transmitter.

**A. SPRING TENSIONS**

**1. Common selector lever**

Page 25, para. 9.5, read: "40 - 60 gms." instead of "60 - 70 gms."

Page 46, para. 6, col. 3, read: "PG.7397" instead of "PG.7374"

Col 4, read: "Force needed to extend spring from  $4\frac{1}{4}$  to  $\frac{7}{8}$  in. (16.3 to 22.2 mms.) is 6 to  $8\frac{1}{2}$  ozs. (170 to 241 gms.). See adjustment 9, page 25."

**2. Striker lever**

Page 27, para. 14.2, read: "160 - 190 gms." instead of "90 - 120 gms."

Page 46, para. 7, col. 2, read: "(26)" instead of "-do-"

Col. 3, read: "PG.7375A" instead of "PG.7374"

Col. 4, read: "Force needed to extend spring from  $\frac{1}{2}$  to  $2\frac{7}{32}$  in. (12.7 to 21.4 mms.) is  $11\frac{1}{4}$  to  $13\frac{1}{2}$  ozs. (319 to 383 gms.). See adjustment 14, page 27."

**B. LUBRICATION**

Pages 44 and 45

Delete sections 2 and 3 and insert the following:-

**"2. AFTER EACH 100 HOURS' WORKING**

**Mobilube GX.140**

Apply a small quantity of oil to the following parts, taking care that no oil reaches the contacts:-

- (a) Felt lubricator for sequential cams )
- (b) Nose of striker cam follower )
- (c) Oil hole in striker cam follower bearing block )
- (d) Rubbing face of striker cam follower retaining collar )
- (e) Guides for striker dart )
- (f) Operating faces between striker dart and its operating lever ) Transmitter Head
- (g) Working faces of common lever stop plate )
- (h) All other accessible pivots and working surfaces on the transmitter head other than those mentioned in the following paragraph )