

**As you are now the owner of this document which should have come to you for free, please consider making a donation of £1 or more for the upkeep of the (Radar) website which holds this document. I give my time for free, but it costs me around £300 a year to bring this document to you. You can donate here <https://blunham.com/Radar>, thank you.**

**Do not upload this copyright pdf document to any other website. Breaching copyright may result in a criminal conviction and large payment for Royalties.**

This document was generated by me, Colin Hinson, from a document held at R.A.F. Henlow Signals Museum which is believed to be out of copyright or Crown Copyright. It is presented here (for free) under the Open Government Licence (O.G.L.) if under Crown Copyright and this version of the document is my copyright (along with the Crown Copyright) in much the same way as a photograph would be. It should be noted that most of the pages are identifiable as having been processed by me. If you believe the original document to be under copyright, please contact me.

The document should have been downloaded from my website <https://blunham.com/Radar>, or any mirror site named on that site. If you downloaded it from elsewhere, please let me know (particularly if you were charged for it). You can contact me via my Genuki email page: <https://www.genuki.org.uk/big/eng/YKS/various?recipient=colin>

**You may not copy the file for onward transmission of the data nor attempt to make monetary gain by the use of these files. If you want someone else to have a copy of the file, point them at the website (<https://blunham.com/Radar>). Please do not point them at the file itself as it may move or the site may be updated.**

---

I put a lot of time into producing these files which is why you are met with this page when you open the file.

In order to generate this file, I need to scan the pages, split the double pages and remove any edge marks such as punch holes, clean up the pages, set the relevant pages to be all the same size and alignment. I then run Omnipage (OCR) to generate the searchable text and then generate the pdf file.

Hopefully after all that, I end up with a presentable file. If you find missing pages, pages in the wrong order, anything else wrong with the file or simply want to make a comment, please drop me a line (see above).

If you find the file(s) of use to you, you might like to make a donation for the upkeep of the website – see <https://blunham.com/Radar> for a link to do so.

*Colin Hinson*

*In the village of Blunham, Bedfordshire, UK.*

72  
**RESTRICTED**

AIR PUBLICATION

**115N-0200-1**

(Formerly A.P.2527R, Vol. 1)

**MARKER UNIT (VIDEO MAP)  
TYPE 30 AND 30A**

BY COMMAND OF THE DEFENCE COUNCIL

*L. T. Dunnett*

Ministry of Defence

FOR USE IN THE  
ROYAL AIR FORCE

(Prepared by the Ministry of Technology)

A.L.16, Mar. 69

**RESTRICTED**

**AMENDMENT RECORD SHEET**

To record the incorporation of an Amendment List in this publication, sign against the appropriate A.L. No. and insert the date of incorporation.

A.L.No.	AMENDED BY	DATE
1	Ch Smith	12.5.54
2	Ch Smith	28/8/54
3	Ch Smith	28/8/54
4	Ch Smith	30/8/54
5	Ch Smith	4.12.54
6	Ch Smith	29/11/54
7	Ch Smith	29/11/54
8	Ch Smith	4.12.54
9	Ch Smith	15.2.55
10	Ch Smith	15.2.55
11	J. Davis	22/12/59
12	H. Jones	3/3/64
13	H. Jones	8/10/64
14	H. Jones	26/10/66
15	B. Friend	28/10/66
16	Emchere	14-1-70
17	S. Brodow	6.4.73
18	T. Daniels	15.5.79
19	R. Manning	31.4.81
20	L.J. Hedgesock	10.12.80
21		
22		
23		
24		
25		
26		
27		
28		
29		
30		
31		
32		
33		

A.L.No.	AMENDED BY	DATE
34		
35		
36		
37		
38		
39		
40		
41		
42		
43		
44		
45		
46		
47		
48		
49		
50		
51		
52		
53		
54		
55		
56		
57		
58		
59		
60		
61		
62		
63		
64		
65		
66		

(Continued overleaf)

# DANGER-HIGH VOLTAGE

An earthing stick is provided. After switching off, use this stick to earth any points which were previously at high potential, before handling.

The CRT anode operates at 15,000 volts. Use great caution when testing with the cabinet door open and the indicating unit swung outward.



**APPARATUS IS SAFE - ONLY IF YOUR APPROACH IS CORRECT**

**RESTRICTED**

NOTE TO READERS

The subject matter of this publication may be affected by Defence Council Instructions, Servicing schedules (-4 or -5) or 'General Orders and Modifications' leaflets in this A.P., in the associated publications listed below, or even in some others. If possible, Amendment Lists are issued to correct this publication accordingly, but it is not always practicable to do so. When an Instruction, Servicing schedule or leaflet contradicts any portion of this publication, the Instruction, Servicing schedule or leaflet is to be taken as the overriding authority.

The inclusion of references to items of equipment does not constitute authority for demanding the items.

Each leaf, except the original issue of preliminaries, bears the date of issue and the number of the Amendment List with which it was issued. New or amended technical matter will be indicated by triangles, positioned in text thus:— ◀ . . . . . ▶ to show the extent of amended text, and thus:— ▶ ◀ to show where text has been deleted. When a Part, Section, or Chapter is issued in a completely revised form, the triangles will not appear.

◀ The reference number of this publication was altered from A.P.2527R, Vol. 1 to A.P.115N-0200-1 in Mar. 69. No general revision of page captions has been undertaken but the code number appears in place of the earlier A.P. reference on new or amended leaves issued subsequent to that date. ▶

LIST OF ASSOCIATED PUBLICATIONS

	<i>A.P.</i>
<i>Information generator for radar stations</i> . . . . .	2527C
<i>Test equipment for mobile and static radar stations</i> . . . . .	2527D
<i>Information generation and distribution for static radar stations</i> . . . . .	2527E

## NOTE TO READERS

The subject matter of this publication may be affected by Air Ministry Orders, or by "General Orders and Modifications" leaflets in this A.P., in the associated publications listed below, or even in some others. If possible, Amendment Lists are issued to correct this publication accordingly, but it is not always practicable to do so. When an Order, or leaflet contradicts any portion of this publication, the Order, or leaflet is to be taken as the overriding authority.

The inclusion of references to items of equipment does not constitute authority for demanding the items.

Each leaf, except the original issue of preliminaries, bears the date of issue and the number of the Amendment List with which it was issued. New or amended technical matter on new leaves which are inserted when the publication is amended will be indicated by triangles, positioned in the text thus :—◀ —————▶ to show the extent of amended text, and thus :—▶▶ to show where text has been deleted. When a Part or Chapter is issued in a completely revised form, the triangles will not appear.

## LIST OF ASSOCIATED PUBLICATIONS

	A.P.
<i>Information generator for radar stations</i> .. .. .	2527C
<i>Test equipment for mobile and static radar stations</i> .. .. .	2527D
<i>Information generation and distribution for static radar stations</i> ..	2527E
<i>Static radar stations Type CHEL</i> .. .. .	2527F

**RESTRICTED**

## LAYOUT OF A.P.2527R

### MARKER UNIT (VIDEO MAP) TYPE 30 and 30A

*Heavy type indicating the books being issued under this  
A.P. number ; when issued they will be listed in A.P.113*

<b>VOLUME 1, Part 1</b>	<b>Leading particulars and general information</b>
<b>VOLUME 1, Part 2</b>	<b>Technical information</b>
VOLUME 1, Part 3	Fault diagnosis ( <i>undecided</i> )
VOLUME 1, Part 4	( <i>Application to be decided later</i> )
<b>VOLUME 2</b>	<b>General orders and modifications</b>
VOLUME 3, Part 1	Schedule of spare parts ( <i>undecided</i> )
<i>VOLUME 3, Part 2</i>	<i>Inapplicable</i>
<b>VOLUME 3,</b> <b>Parts 3 and 4</b>	<b>Scales of unit equipment and servicing spares</b>
VOLUME 4	( <i>Application to be decided later</i> )
VOLUME 5	( <i>Application to be decided later</i> )
<i>VOLUME 6, Part 1</i>	<i>Inapplicable</i>
VOLUME 6, Part 2	( <i>Application to be decided later</i> )
<i>VOLUME 6, Part 3</i>	<i>Inapplicable</i>

**RESTRICTED**

**PART I**

**LEADING PARTICULARS AND GENERAL INFORMATION**

**LIST OF CHAPTERS**

*Note.*—A list of contents appears at the beginning of each chapter

- 1 General description**
- 2 Setting-up instructions**

*The above list indicates the ultimate contents of the part. The present contents are listed on the page which follows the contents marker card*

**RESTRICTED**

## Chapter 1

### GENERAL DESCRIPTION

#### LIST OF CONTENTS

General principles	Para.	Photo-electric cell ... ..	Para.
<i>Introduction</i> ... ..	1	<i>Electron multiplier photo-cells</i> ... ..	18
<i>Development of video map technique</i> ... ..	4	<b>General description</b> ... ..	23
<i>Principle of operation</i> ... ..	7	<i>Scanning assembly</i> ... ..	29
<i>Video cartography</i> ... ..	11	<i>Optical system</i> ... ..	30
			42

#### LIST OF ILLUSTRATIONS

	Fig.		Fig.
<i>Video map, basic principle</i> ... ..	1	<i>Marker unit with indicating unit partly swung back</i> ... ..	5
<i>Photo-electric multiplier, basic principle</i> ... ..	2	<i>Indicating unit (c.r.t.) Type 33, upper portion</i> ... ..	6
<i>Photo-electric multiplier, CV337, electrode arrangement</i> ... ..	3	<i>Marker unit, schematic diagram</i> ... ..	7
<i>Marker unit (video map) Type 30 (operating position)</i> ... ..	4		

### GENERAL PRINCIPLES

#### Introduction

1. When the p.p.i. display of radar information was first introduced, the position of a target was generally reported in terms of bearing (azimuth) and distance (range) from the radar station. Range markers in the form of concentric circles, and azimuth markers in the form of radial lines (both types having the origin of the p.p.i. scan as centre) were found to be desirable, and were at first provided by a suitably engraved transparent window fitted closely over the face of the c.r.t.; eventually however it became possible to display such markers directly upon the c.r.t. screen by comparatively simple electronic techniques.

2. When these markers are in use, in order to determine an exact position in terms of map references, it is necessary to plot the distance and bearing of the target, with relation to the geographical position of the radar station, on the appropriate section of a gridded map of the area covered by the station. It was soon realized that considerable operational advantages would be obtained if the position of the target could be shown directly upon a map of this kind, since its location then becomes merely a matter of direct observation.

3. Since the introduction of electronic range and azimuth markers, a gridded map is sometimes provided on a p.p.i. display by placing a transparent window, with the map engraved upon it, in front of the c.r.t. screen, the markers being used to adjust the scale of the display to that of the map. This however gives rise to errors in reporting owing to the presence of parallax; the latter may be eliminated by discarding the window, and painting the map directly upon the face of the c.r.t. Both these methods suffer from the obvious disadvantage that any particular map of the area covered by the station

is of use only so long as the station remains static. Should the station be moved, either a new window must be fitted, or a new map must be painted upon the c.r.t. face.

#### Development of video map technique

4. The marker units (video map) Type 30, and the extra-long-range-version, Type 30A, have been developed to provide such a map directly upon the p.p.i. display by electronic means. The resulting display (and the means of its production) is known as a "video map." The video map unit was intended primarily for use with console Type 60A, but its use has been extended to other p.p.i. consoles, e.g. Type 64.

#### ◀ Note . . .

*For certain applications where a special repeater amplifier is required (Part 2, Chap. 4, App. 1) the video map cabinet has been given the nomenclature 'cabinet electrical equipment Cat. No.5975-99-970-2307'. This allows greater flexibility in the make-up of units which form the video map. The units housed in the cabinet thus cease to be part of the assembly and any combination of units required may, be assembled in the cabinet without further modification, providing the cabinet wiring is unchanged.*

5. The video mapping system provides facilities whereby quite considerable changes on the location of the station can be provided by a simple adjustment. The map shown on the display can thus be moved so that the map is re-centred on the new position of the station.

6. Both the window system and the painted map suffer from severe limitations, when, as is normally the case, the main p.p.i. display is broken up into a number of expanded sector displays. Using the video map system, however, the map is an integral part of the complete

**RESTRICTED**

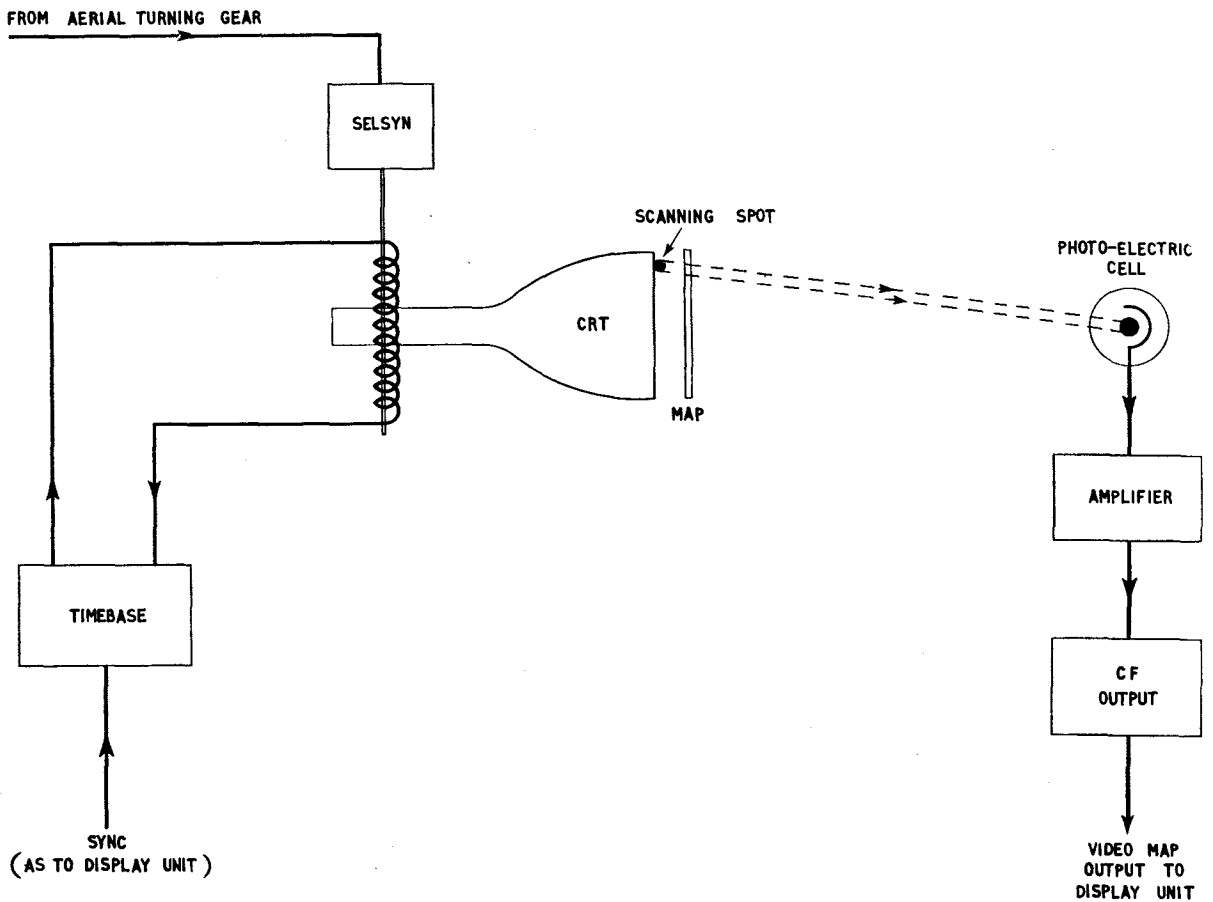

Fig. 1. Video map, basic principle

p.p.i. display display, and when a section of the display is transferred (as an expanded sector display) on to a separate tube, the portion of the video map associated with that sector is transferred with it, on the appropriate scale, and the appropriate portion of the map will appear automatically upon the c.r.t. screen.

#### Principle of Operation

7. The basic principle of the method of generating the video map is shown in the schematic diagram (fig. 1). The deflection coils of a projection-type c.r.t. are fed, from a timebase, synchronized from the same source as the p.p.i. display timebase. Further, the deflection coils are rotated round the neck of the c.r.t. by a receiving selsyn controlled by a transmitting selsyn on the aerial turning gear, the system in effect being a duplicate of the scan selsyn system on the p.p.i. console. As a result, a rotating radial trace (synchronized and aligned in azimuth with the scan on the p.p.i. console) appears on the mapping c.r.t. This trace is not modulated by signals as in the p.p.i. display, but appears as a continuous bright line.

8. A photo-electric cell (para. 18-28) is placed where the light from the c.r.t. trace can fall upon it, and a facsimile of the map which it is desired to produce upon the p.p.i. display is placed between it and the tube face. This map takes the form of a photographic negative, in which the detail of the map is formed of transparent lines upon an opaque background. The photo-

electric cell is illuminated only when the transparent sections of the map pattern are scanned by the rotating beam; the output of the photo-electric cell will therefore consist of a series of pulses whose amplitude is proportional to the intensity of the light passing through any given point on the map at the instant when that point is scanned by the rotating beam. Since the map consists only of clear lines upon a very opaque background, the pulses will all be of sensibly equal amplitude.

9. The video output of the photo-electric cell is amplified and passed to the p.p.i. console, where it is applied as positive-going pulses to the control-grid of the p.p.i. tube. The video map, an exact copy of the actual map being scanned, will now appear on the p.p.i. display.

10. Two principles not in general application are thus used in the video mapping system; these are (a) the production of suitable maps for this purpose, and (b) the production of a video signal by means of a photo-electric device. As these may not be familiar, they are discussed briefly in the following paragraphs.

#### Video cartography

11. To provide the glass-slide maps necessary for this equipment, a special technique has been evolved; the design and production of these maps has been conveniently termed "video cartography." In the brief description that follows it is intended to explain the basic methods used for the production of the maps.

12. The first stage of the process is the drawing of a master map ; this must satisfy certain requirements which are found from practical experience to be essential. For example, the map must be accurately drawn, the thickness of the lines being within certain specified limits, and showing all the necessary detail such as coast-lines, reference lines and reference letters. With the two map-scales used, the maximum line width is equivalent to 0.25 miles in the case of the 120 mile scan, and 0.5 mile in the 240 mile scan.

13. The original master map is drawn to cover as wide an area as possible, in order to obtain maximum utility with the smallest number of masters. There are limits in this respect owing to operational requirements and the particular projection used, but this matter is outside the scope of this Chapter.

14. Master glass maps (which are of the correct scale and form permanent reduced copies of the original basic drawing) are produced from the drawn master map. It is at this stage that most of the precision work is required, since the master glass maps are produced by photographic means so that they appear as a photographic positive. They are composed of dark lines on a clear background, and the contrast must be as great as possible. The individual station maps are contact-printed from these glass master maps.

15. A standard  $3\frac{1}{4}$  in. projector slide is used for the individual station map. A border of  $\frac{1}{4}$  in. wide around the edges of the slide is allowed for protective binding, so that the effective working area is  $2\frac{3}{4}$  in. square. As has been said, these maps are directly contact-printed from the master glass map and the finished map must possess the greatest possible contrast between black and white. The ideal would be complete transparency in the clear areas with complete light obstruction in the opaque area. When making the contact print, the glass slide is centred on the desired point on the master, and arranged so that its edges are aligned parallel to the reference lines of the master. In this way an individual station map, covering an area centred on any given point on the master, is produced.

16. This system provides flexibility of use even in the case of a mobile station. Movement of the station location within limits of +90 miles or  $\pm 180$  miles, dependent upon the scale in use, can be compensated for by movement of the map already in use by the adjustments provided in the optical system. When the station location is changed outside these limits a new map, centred on the new station position, can be produced from the master glass map.

17. An advantage of this system is that any kind of information in the form of clear areas on an opaque background, may be distributed via the scanning head should the occasion arise. Maps showing such information as meteorological data are one example. Such information might be required to be changed rapidly, and the design of

the scanning head is such that any change may be carried out easily and quickly.

#### Photo-electric cell

18. When a conductive material absorbs electromagnetic radiation in the visible, infra-red or ultra-violet range of the spectrum, one (or more) of the following three effects may be observed, viz., (i) the incident radiation may cause an emission of electrons from the surface of the material, (ii) the conductivity of the material may change, or (iii) an EMF may be set up in it. These phenomena are known as the photo-emissive effect, the photo-conductive effect, and the photo-voltaic effect, respectively ; only the former need be considered for the present purpose.

19. The photo-emissive effect is observed on the surface of metals or metal compounds. The simplest possible type of photo-electric cell using this principle consists of a photo-sensitive cathode, with an anode electrode, enclosed in an evacuated glass envelope. The anode is given a positive potential with respect to the cathode ; when light is directed on the cathode, electrons are emitted from its surface and are accelerated toward the anode by the electrostatic field. Anode current will flow, proportional to the intensity of the light falling upon the cathode. Fluctuations of light intensity will be accompanied by corresponding variations of anode current.

20. The value of the anode current is not, however, only dependent upon the intensity of the radiation falling upon the photo-sensitive cathode ; the response of a photo-electric cell varies considerably with the wavelength of the incident radiation, and the range of light wavelengths over which the photo-cell gives maximum response is determined by the material of which the cathode is constructed.

21. The earliest types of photo-cathodes were made from pure metals such as zinc and aluminium. These were superseded in time by alkali metal and alkali-hydride cathodes. The modern photo-cathode is, however, generally one of two types known as "composite cathodes" and "alloy cathodes" respectively. The silver-oxygen-caesium (Ag—O—Cs) cathode is an example of the composite type, and the antimony-caesium cathode (Sb—Cs) is an example of the alloy type.

22. The response of these two types of cathode may be given as an example of the way in which sensitivity varies with cathode material. The Ag—O—Cs cathode has a maximum response in the long-wave, almost infra-red, portion of the spectrum at about 8,000 Angstrom, and a further peak response in the ultra-violet at about 3,500 Angstrom. The Sb—Cs cathode has its maximum sensitivity in the visible portion of the spectrum and it is most sensitive to blue light at about 4,600 Angstrom. This type of cathode is generally used for applications such as the system used in the video mapping unit.

Note . . .

For practical purposes an Angstrom unit may be taken as  $10^{-8}$  cm.

### Electron multiplier photo-cells

23. Since the initial electron current produced from the surface of the photo-sensitive cathode of a photo-electric cell is very minute, considerable amplification is necessary before the output from the photo-electric cell can be put to practical use. Such amplification may be carried out by a series of valve amplifier stages, but a method has been developed, based upon the secondary emission effect, which permits amplification of the electron current within the cell itself by electronic multiplication. Such a device is known as a photo-multiplier.

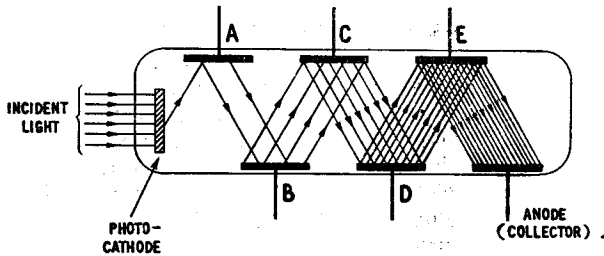

Fig. 2. Photo-electric multiplier, basic principle

24. When primary electrons are made to strike a target they may liberate secondary electrons from it. The yield of the secondary electrons, i.e. the average number of secondary electrons released by each primary electron, is called the secondary emission coefficient. This quantity depends upon the energy of the primary electrons, the material of which the target (often known as a "dynode") is constructed, and the angle of incidence of the primary electrons. The same materials are used for the targets as for the photo-sensitive cathodes, since they have a high secondary emission yield.

25. The general method involved is to allow the initial electron stream to impinge on a target which has been sensitized for secondary emission. In fig. 2 target electrodes A, B, C etc. represent a number of plane targets, and these electrodes are connected to successively higher potentials. The stream of electrons to be multiplied is directed against A, giving rise to secondary electrons which are directed at B where in turn tertiary electrons are emitted. This process can be repeated with a series of targets until the desired amplification is produced by the multiplication process, and the electrons are then collected by the anode "collector" electrode. The amplification of such an arrangement is high; if the secondary emission co-efficient is  $K$  and the number of targets  $n$ , the overall amplification will be given by  $K^n$ .

26. The simplified arrangement of fig. 2 would, however, be of little practical use. With such an arrangement the electrons leaving any target would

not go to the next target but would travel down the tube directly to the anode. The targets must not only have a high secondary emission coefficient but some means must be provided to focus the electrons on to each target and to draw away secondary electrons from one target preparatory to focusing them on the next. A variety of methods are used in different designs of multiplier, using both magnetic and electro-static focusing. An excellent example of one such system is that used in the CV337, the tube used in this equipment.

27. The CV337 is a nine-stage photo-multiplier tube having its maximum response in the blue region of the spectrum. Cathode, anode and the nine dynodes are contained in an evacuated glass envelope, with an 11-pin base. The tube must always be mounted in an upright position, the incident light being directed to the centre of the cathode through an aperture of dimensions 0.8 in. by 0.2 in. In the optical assembly of the video mapping unit an adjustable mirror is provided so that the maximum possible amount of light falls upon the photo-cathode via this aperture.

28. An illustration of the internal electrode construction of the CV337 is given in fig. 3; this is sometimes known as the "zig-zag" type of multiplier. Focusing of the electron stream is achieved by a geometrical arrangement of specially shaped dynodes, their potentials increasing in equal steps above the cathode potential; the effect of the electrode shape and the resultant combined electrostatic field is to guide the electrons emitted from the photo-cathode O to the first dynode (1) so that they impinge at the optimum angle for maximum secondary emission, and then to collect the emitted electrons of dynode 1

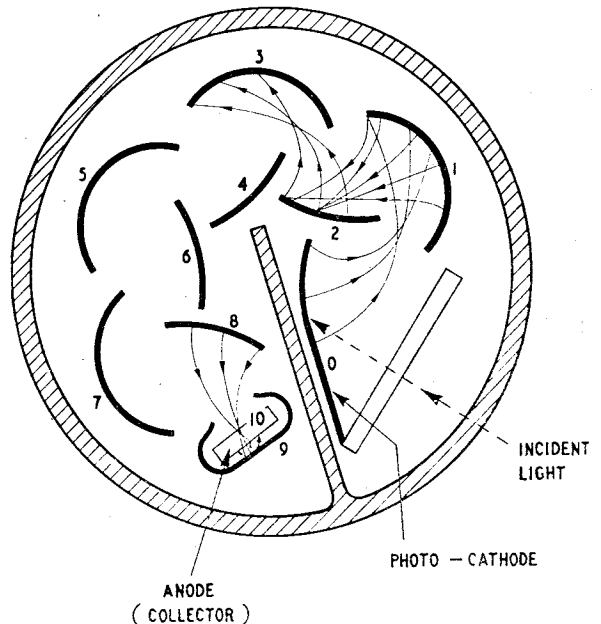

Fig. 3. Photo-electric multiplier, CV337, electrode arrangement

for transmission to dynode 2. This process is repeated in a zig-zag manner (shown in fig. 3) so that the electron stream is focused from dynode to dynode until the electrons reach the collector electrode (10). This system gives the CV337 a gain of some  $10^5$ , using a final cathode-anode potential of 1,000 volts.

### GENERAL DESCRIPTION

29. The marker unit (video map) Type 30 is developed from the basic arrangement described in para. 7-10. The Type 30A is the extra-long-range version the only difference being that the Type 30A is fitted with a modified timebase unit, Type 137A instead of the normal timebase unit

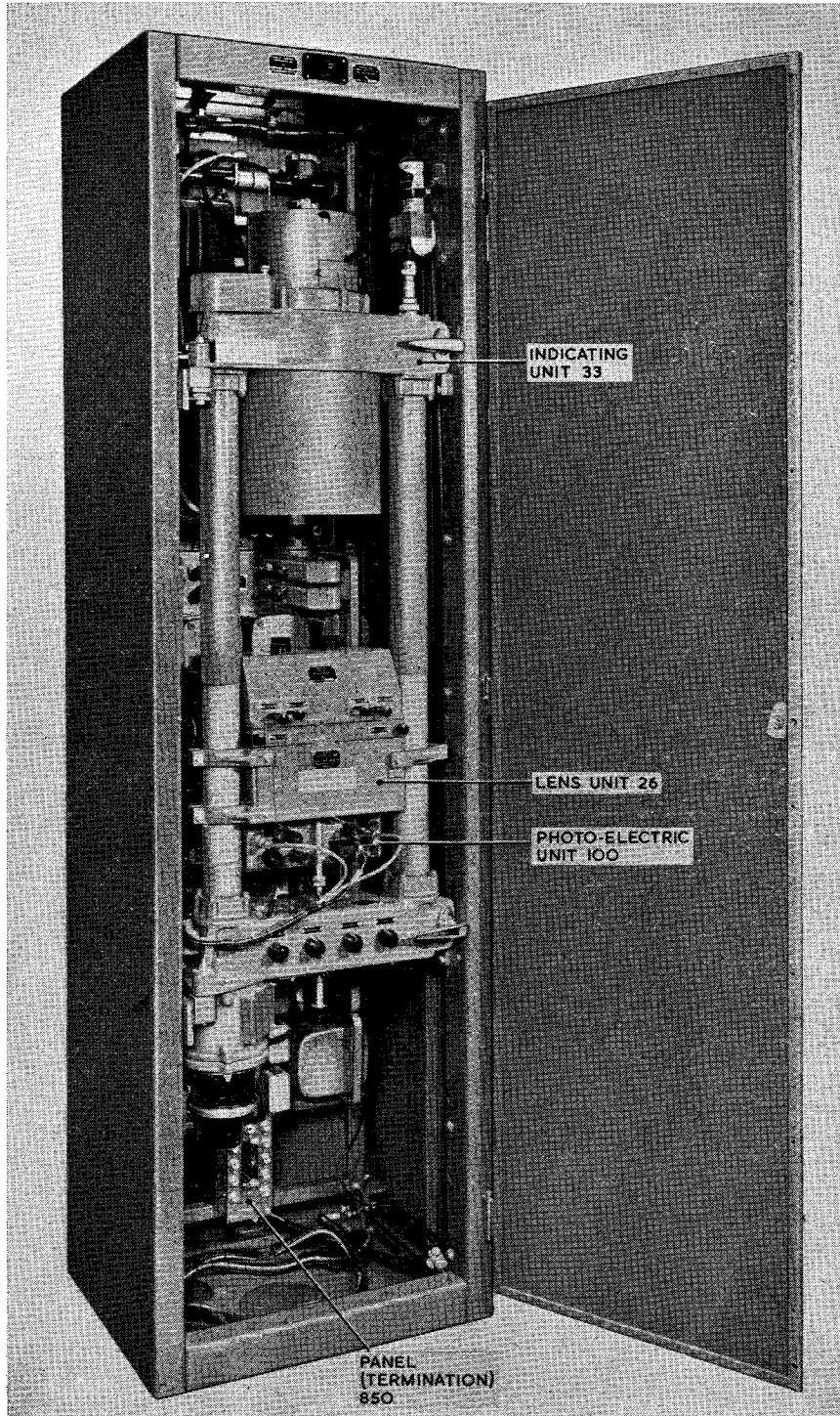

Fig. 4. Marker unit (video map) Type 30 (operating position)

**RESTRICTED**

Type 137. The marker unit is a self-contained unit built into a steel cabinet as shown in fig. 4 and 5. Fig. 4 shows the Type 30 unit in its operating position except that the front door is open for inspection. The large unit in the front will be referred to for brevity as the scanning assembly ; it consists of the indicating unit (CRT) Type 33, the lens unit Type 27, and the photo-electric unit Type 100, the latter being bolted to the underside of the lens unit, so that the two form a single assembly which is bolted to the two support tubes which form part of the indicating unit. The principal features of the marker unit will be described with reference to fig. 4, 5, 6 and 7, the latter being a schematic diagram showing the optical path from the CRT to the photo-electric multiplier, and also the broad principles of the power distribution system. This must not be regarded as a circuit or wiring diagram, however ; these are given in Part 2 of this Volume.

### Scanning assembly

30. The indicating unit consists basically of two light alloy castings, called the top and bottom castings, which are joined by the two support tubes to form a rectangular structure which is attached to the left-hand side of the cabinet by massive hinges and when in the operating position, is locked in that position by catches with car-type handles. When swung forward for access to the interior of the cabinet, the unit is retained in position by a spring-loaded catch.

31. The indicating unit contains the projection CRT, with deflection coil, centring coil, focusing coil, auto-align cam, deflection coil rotating system, and CRT controls, the latter being mounted on the vertical side of the casting which holds the support tubes at the bottom of the unit.

32. The CRT is a 7 in. projection tube (CV2897) having a flat face. All electrical connections to the tube, with the exception of the EHT supply and the brightening pulse, are made through the base cap, which is carried on the end of a branch of the main cable loom. The EHT supply is at 15kV, derived from the EHT unit.

33. The deflection coil waveforms, and the brightening pulse, are derived from the timebase unit ; the former is fed into the indicating unit at sockets SK.3, SK.4 and thence to the coil through spring contacts and slip-rings. The brightening pulse is applied to the cathode and is fed into the unit at SK.5. The points are shown on the photograph of the upper portion of the unit (fig. 6). The deflection coil itself is wound on a tube forming part of an assembly which is rotated through a gear train driven by the receiving selsyn. The latter can be seen at the bottom of the left-hand support tube in fig. 4 and 5. The drive is taken by a light alloy shaft fitted in the interior of the support tube with ball bearings at top and bottom. The speed is reduced in a ratio of 30 to 1 by a gear train housed under the removable gearing cover, so labelled in fig. 6.

34. An auto-aligning device is associated with the deflection coil assembly in the form of a metal

cam ring, which is circular except for a projection at one point. This projection closes a pair of contacts once per revolution of the deflection coil, causing the operation of a relay mounted on the inner side of the bottom casting. If the CRT trace is out of azimuthal alignment with the aerial, the receiving selsyn is disconnected from line and short-circuited upon itself in such a manner that it is rigidly locked until the aerial rotates into line with the bearing upon which the trace is stationary ; at this point the relay is released, and the trace continues to rotate in synchronism with and lined up to the aerial. Details of the auto-align system are given in Part 2, Chap. 2 of this Volume.

35. The CRT is magnetically focused, the focus coil being mounted in gimbals carried by a plate which can be moved to and fro in both N-S and E-W directions, and also tilted in two mutually perpendicular directions. These adjustments are made by screws accessible through the upper screening can (fig. 6). The fine focusing is carried out by varying the current in the focus coil, the control being mounted on the lower casting. A pentode V2, located on the inner side of the bottom casting, acts as a constant-current device to maintain the focus coil current at the desired value as set by the focus control.

36. Centring is provided by coils fed from the +300-volt and -300-volt sources, and brilliance control from the -300-volt source. The four controls just mentioned, viz. BRIGHTNESS, CENTRING 1, CENTRING 2, and FOCUS, are those seen on the bottom casting in fig. 4. The connections to the indicating unit are made through two Jones plugs A and B, mounted on the inner side of the bottom casting, and visible in fig. 5. The whole of the wiring, except for coaxial leads and the EHT connector, is carried in a cable-form which extends from PL.B. through the right-hand support tube, and extends to the valve cap on the CRT stem. A branch of this is connected through a socket SK.P and plug PL.B to terminal blocks for the focus coil, centring coils and auto-align contacts.

37. The lens unit contains the field lenses, map carriages carrying the glass map slides, and mirrors for the deflection of the scanning beam on to the photo-electric cells. The photo-electric unit contains the photo-electric cells (which are so mounted as to be inside the lens unit) and a head amplifier. The output of the latter is a video signal which is fed into the amplifying unit (video) Type 298.

38. Fig. 5 shows the scanning assembly swung partly forward, so exposing the front panels of the various ancillary units. These are labelled in the photograph. The power unit (EHT) provides the EHT supply for the projection CRT. The timebase unit Type 137 provides the deflection wave-form and a brightening pulse for the CRT during the forward stroke of the timebase. The amplifying unit (video) Type 298 accepts the video output of the head amplifier in the photo-electric unit, and provides (for each map) five parallel outputs from which that number of PPI displays may be fed.

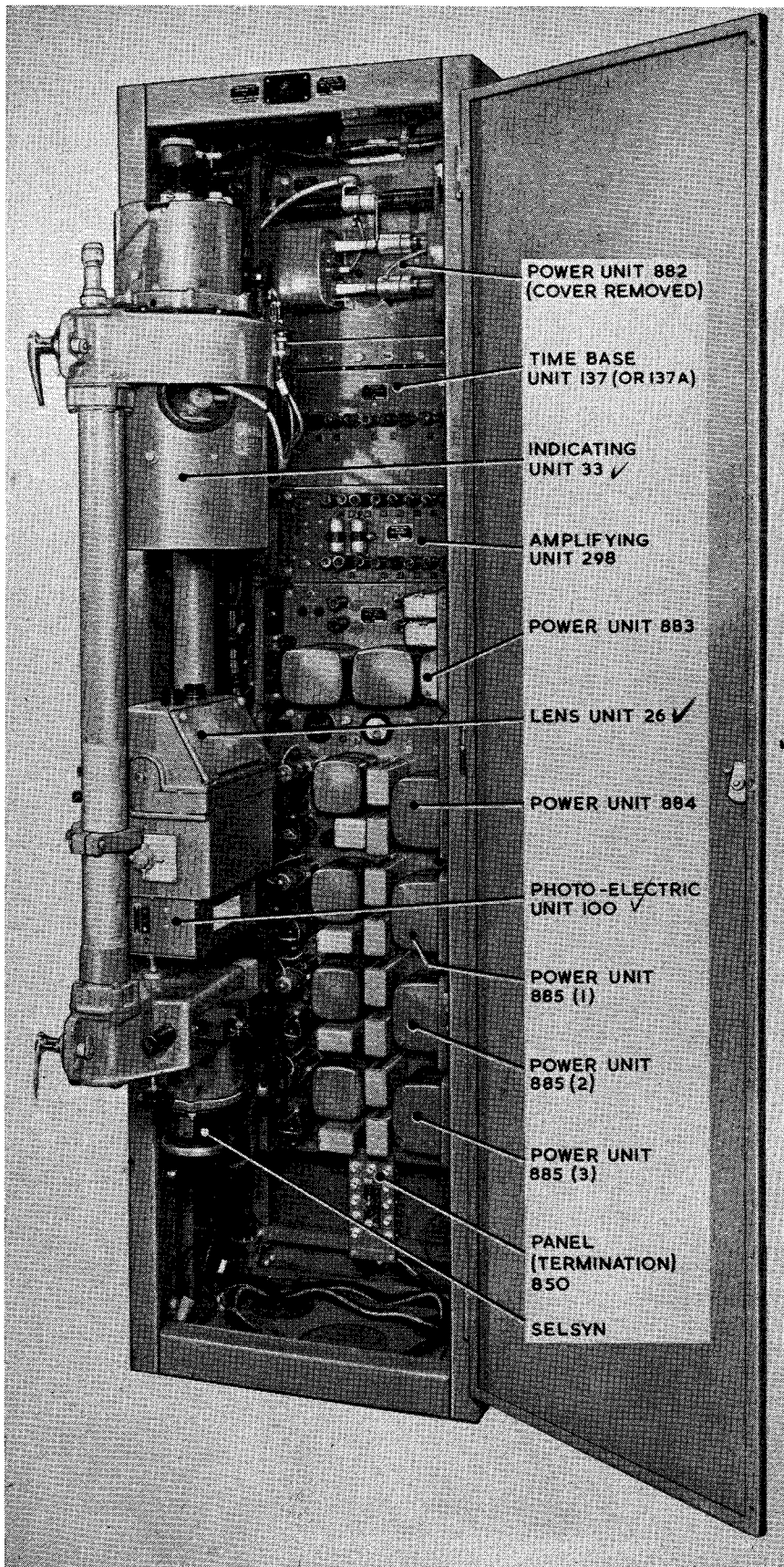

Fig. 5. Marker unit with indicating unit partly swung back

**RESTRICTED**

39. The power unit (MHT) Type 883 provides a —1,000-volt supply for the operation of the photo-electric multiplier, and the power unit (—300V) Type 884 provides negative bias voltages for all other units as required. The three power units (300V) Type 885 provide HT supplies for the various valves in the ancillary units.

40. A small relay panel known as switch unit Type 504 is mounted on the left-hand side of the cabinet behind the scanning assembly, so that it is

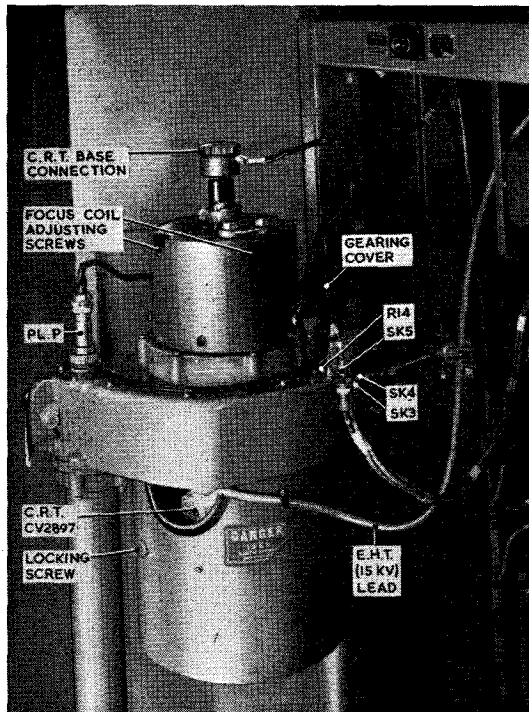

Fig. 6. Indicating unit (CRT) Type 33, upper portion

only accessible after the latter has been swung outward. This relay system ensures that power supply to the EHT power unit is not completed until the negative bias rectifier is developing its full output.

41. The external requirements for the operation of the marker unit are

- (1) a 230-volt, 45–65 c/s AC mains supply,
- (2) driving power for the receiving selsyn, and
- (3) a sync pulse from the same source as the associated PPI timebases. The selsyn driving power is obtained from a transmitting selsyn fitted on one of the synchronously-rotating aerial heads.

#### Optical system (fig. 7)

42. The lens unit Type 26 contains two separate and complete optical systems, each consisting of a field lens (mounted on top of the unit as shown in fig. 4), a glass map in its slide on the map carriage, and a condenser lens which projects the light pulses

on the cathode of the photo-electric cell. A plane metal mirror is fitted to turn the beam through approximately 90 deg. so as to permit a convenient means of mounting the photo-electric cell, the cathode window of which is at the side. The light from the moving spot on the CRT trace is focused by the field lens to pass through the map, and the light is projected on to the cathode of the cell by adjustment of the mirror. The procedure is given in the following chapter.

43. The wide-angle characteristic of the field lenses permits the two maps to be scanned simultaneously by the one rotating radial scan. This permits two maps to be available for display at any time ; for example, one may carry “coarse” and the other “fine” detail of the same area, so that the operator may maintain a general watch over the area covered by the map, using coarse detail. When it is required to report an actual plot. the map can be changed to show fine detail.

44. Suitable maps for scanning, prepared as described in para. 11-17 must be inserted in the slides of the map carriages. The ranges scanned are :

- (1) Short range 100-140 miles
- (2) Long range 220-260 miles
- (3) Extra long range 300-340 miles

Under normal condition, 120-mile or 240-mile scans will be used, with maps photographed on a scale of 120 miles or 240 miles per inch respectively. With the extra-long-range version, Type 30A, a 320-mile scan is used. The scale of the map in this case is 320 mile per inch. The two maps can be adjusted in their own plane by means of the map carriage settings ; in this way the scan can be centred on any desired point on the map (usually the station location) within the range of adjustment. For the 120-mile scan, this is  $\pm 90$  miles, and for the 240-mile scan it is  $\pm 180$  miles.

45. The whole assembly consisting of the lens unit Type 26 and photo-electric unit Type 100 can be moved in relation to the CRT face by sliding up (or down) the supporting tubes. The lens unit is fitted with three stirrup brackets for this purpose, one on the left and two on the right-hand side (fig. 4). These brackets are normally clamped tightly to the tubes by bolts. When the latter are slackened off, however, and the assembly is free to move up or down, the image of the CRT trace can be focused on either of the maps by using the focusing screw which passes downward through the bottom casting and is fitted with a fluted head for ease of adjustment. Locking nuts are fitted to this screw so that the focus, once obtained, shall be preserved.

46. Since the field lenses of the two separate optical systems are accurately matched, both systems are focused simultaneously by this adjustment ; this ensures the equal magnification of the images. This equal magnification is essential if two maps on the same scale, but of different complexity, are to be scanned.

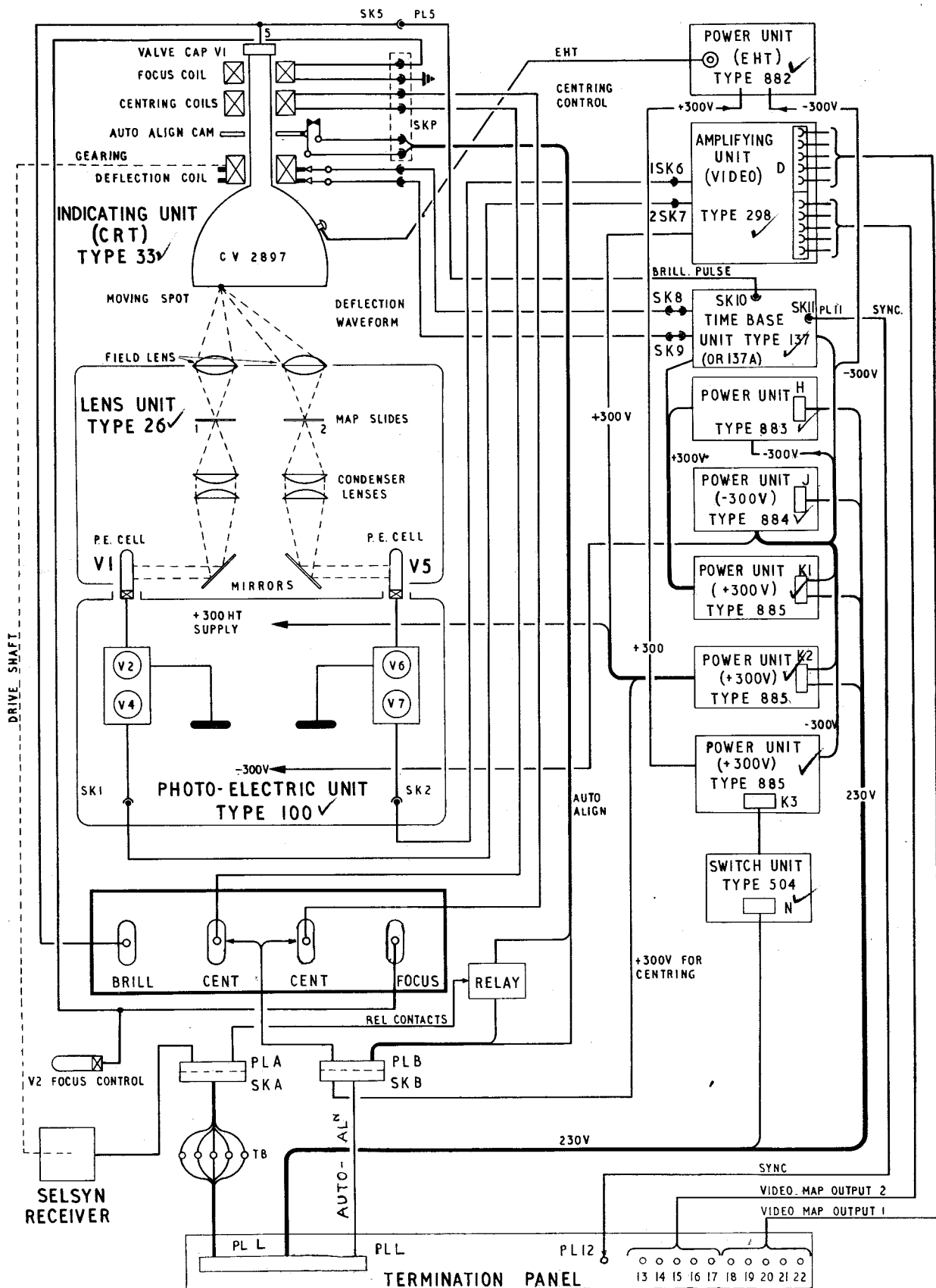

Fig. 7. Marker unit, schematic diagram

RESTRICTED

Chapter 2

SETTING-UP INSTRUCTIONS

LIST OF CONTENTS

	<i>Para.</i>		<i>Para.</i>
<i>Introduction</i> ... ..	1	<i>Timebase ranges</i> ... ..	15
<i>Complete setting-up</i> ... ..	2	<i>Photo-electric unit, lens unit and video amplifier</i> ...	16
<i>Preliminary</i> ... ..	3	<i>Functional tests</i> ... ..	18
<i>Power units</i> ... ..	6	<i>120-mile range</i> ... ..	20
<i>General check on c.r.t.</i> ... ..	7	<i>240-mile range</i> ... ..	22
<i>Photo-electric unit Type 100</i> ... ..	8	<i>320-mile range</i> ... ..	23
<i>Data mile</i> ... ..	10	<i>Preparation for operating</i> ... ..	25
<i>Test slide</i> ... ..	11	<i>Changing the c.r.t.</i> ... ..	29
<i>Focus control</i> ... ..	13	<i>Optical focus</i> ... ..	32
<i>Centring</i> ... ..	14		

LIST OF ILLUSTRATIONS

	<i>Fig.</i>
<i>12-ring test slide pattern, enlarged</i> ... ..	1
<i>Test slide pattern waveform on oscilloscope</i> <i>Type 13A</i> ... ..	2

**Introduction**

1. The setting-up instructions given in this Chapter are intended to cover both the standard and the extra-long-range versions (Type 30 and Type 30A). Although the text mainly refers to the standard version a similar setting-up procedure is required for the Type 30A. The procedure for setting the 320-mile range markers is described in para. 23.

**Complete setting-up**

► **Note ...**

When replacing a selsyn receiver, or in cases where the auto-align system is suspect, reference should be made to the appropriate alignment procedure detailed in AP115H-2201-1 Vol. 1, Sect. 1, Chap. 5.

2. The complete setting-up procedure is necessary only when the marker unit has been out of use for a considerable period, or on restoration to service after repair. Once this procedure has been carried out, the marker unit should remain in alignment, subject to the functional checks detailed in Para. 18-23 which should be applied periodically as laid down in Station or Unit Orders.

*Preliminary*

3. Before commencing to set up, ensure that all valves are inserted, the gearing clamp released, and the BRIGHTNESS and FOCUS controls on the indicating unit set fully counter-clockwise. The control RV1 on the e.h.t. power unit must also be set fully counter-clockwise.

4. Ensure that selsyn supplies from an aerial head are available, together with 230-volt mains supplies. These are fed into the marker unit at PL1 on the termination panel. A sync. pulse from one of the variants of rack assembly Type 181 or 182 (master trigger unit) must be fed to SKT12 on the termination panel, and thence to PL11 on the timebase unit Type 137. The sync. pulse should be approximately 250 c/s.

5. Check the time delay of No. 3 (bottom) power unit (+300V) Type 885, by means of the lamps fitted across the input. This unit is switched on automatically by the switch unit Type 504; the delay should be approximately 15 seconds. This power unit supplies the h.t. voltage for the e.h.t. power unit Type 882.

◄ **WARNING ...**

Before removing the cover of the e.h.t. power unit or touching the anode cap of the c.r.t., the bottom power unit must be switched off, and the anode cap of the c.r.t. earthed by means of the earthing stick provided.

*Power units*

6. The power units should then be set up as follows:-

(1) *Power unit (-300V) Type 884.* Set the multimeter 12889 (Ref. No. 5QP/17227) to the 1000-volt range and connect between pin 11 of plug PL1 and earth. Adjust RV1 on the power unit for an output of -300 volt. After setting, check on the 1000-volt range of the meter.

(2) *Power unit (+300V) Type 885.* Set the multimeter 12889 to the 1000-volt range and connect between pin 9 to PLK (on the top +300V power unit) and earth. Adjust RV2 on the negative 300V power unit for an output of 300 volts. After setting, check on the 1000-volt range of the test meter.

(3) Check the middle +300V power unit in the same manner, adjusting by RV3 on the negative 300V power unit.

(4) Set the bottom +300V power unit in the same manner, adjusting by RV5 on the negative power unit.

(5) *Power unit (MHT) Type 883.* A voltmeter reading up to at least 1500 volts is required for this test; a multimeter 12889 on the 2500-volt range is suitable. Before connecting the meter, the power should be switched off, and the smoothing filter condensers discharged. Then switch on again and wait for the bottom +300V power unit to operate. Adjust the output of the MHT power unit to -1000 volts by means of RV4 on the negative power unit.

(6) *Power unit (EHT) Type 822.* A test meter Type 100 (electrostatic voltmeter, 18.5kV) is used (see Note). Switch off the power supply, discharge the smoothing condensers in the power unit by means of the earthing stick, and connect the voltmeter to the output terminal of the power unit (or to the anode cap of the c.r.t. with the e.h.t. lead connected). Switch on the power supply and wait for the e.h.t. unit to warm up. Adjust RV1 on the e.h.t. power unit for an output of 15kV. When satisfactory, switch off the power supply and disconnect the test set. Check that the h.t. connector is correctly fitted between power unit and anode cap before switching on the power supply.

**WARNING . . .**

The cable used to connect the test meter Type 100 must be adequately insulated for the voltages likely to be encountered. Personnel must stand clear of the meter and cable during this test.

(7) Check the readings obtained on meter M1 of the negative power unit. These should be as follows:-

<i>Switch position</i>	<i>Meter reading</i>
EHT	1.85 to 3.15
MHT	1.8 to 2.2
A.V.	2.85 to 3.15
T.B.	2.85 to 3.15
-300V	2.85 to 3.15

*General check on c.r.t.*

7. Turn up the BRIGHTNESS control and inspect the c.r.t. face (using the mirror assembly if necessary) to ensure that a trace is being produced. Then reduce the brilliance and allow the equipment to run for at least ten minutes with the selsyn rotating to warm up.

*Photo-electric unit Type100*

8. Monitor the anode current of the following valves in the photo-electric unit; these should lie between the limits quoted:-

<i>Monitor point</i>	<i>Valves</i>	<i>Current limits</i>
X2 and X5	V2 and V6 (with RV1 and RV2 in MINIMUM position)	2-10mA
X3 and X6	V4 and V7	2-5mA
X1 and X4	V1 and V5	zero (or slightly negative)

9. After the foregoing checks have been made, the marker unit may be set up as detailed in the following paragraphs. In all tests calling for a stationary trace on the c.r.t., the brilliance must be reduced to the lowest possible level at which the tests can be performed. This is necessary to avoid burning the screen of the c.r.t.

*Data mile*

10. The data mile (2000 yd) system has replaced the nautical mile (2027 yd) system (which was previously employed). The data mile test slides are stowed in a holder mounted on the inside surface of the front door of the marker unit.

*Test slide*

11. Test slides are provided for use during the setting-up operations. These are fitted in the map carriages of the lens unit Type 26. The pattern displayed by the 12-ring (120/240 mile) test slide is shown in fig. 1. The 320-mile test slide employs only eight rings. The pattern consists of a series of concentric circles (range markers) by which the scale of the display on the c.r.t. may be made to coincide with the scale of the p.p.i. timebase, as shown by the normal p.p.i. calibration marks. The concentric circles on the test slide are broken at four places, the breaks occurring at N, E, S and W, to facilitate the setting of the map carriage with respect to the N-S axis of the indicating unit c.r.t.

12. The test slide pattern also includes four squares filled with fine diagonal lines, for testing the resolving capability of the assembly. These are referred to as 'resolution lines'. These lines are made use of in setting the optical focus of the lens unit as described later. Note that there are both fine (50-line) and coarse (36-line) squares.

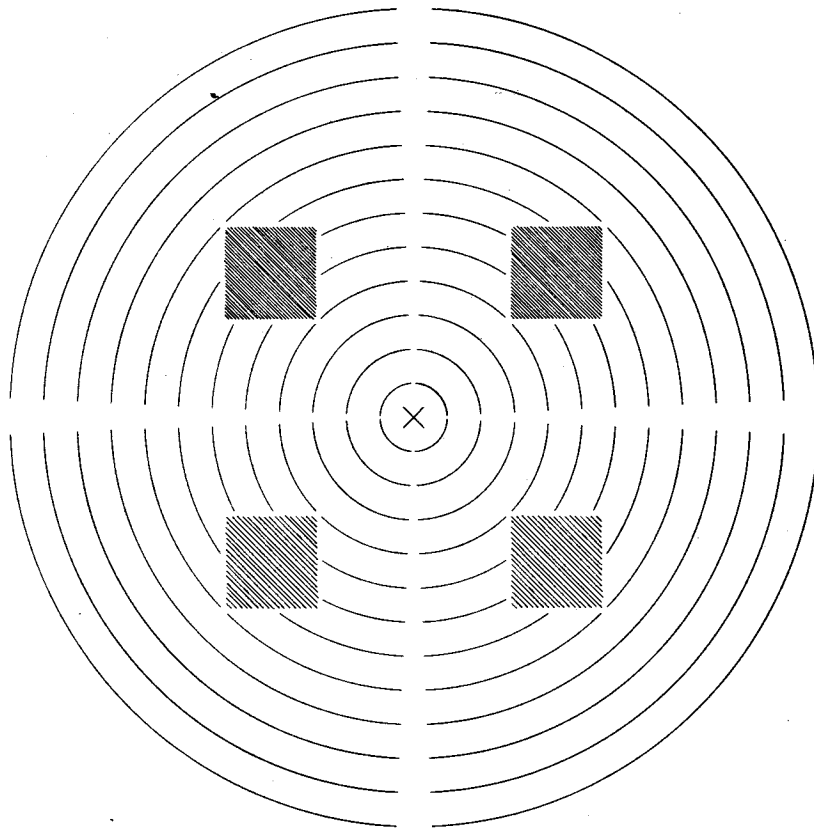

Fig. 1. 12-ring test slide pattern, enlarged

#### Focus control

13. The procedure for adjusting the focus control is as follows :—

- (1) Insert a test slide in each map carriage in the lens unit Type 26.
- (2) Remove the sync pulse from the time-base by removing plug PL11 from timebase unit Type 137.
- (3) Remove plug PLP from the socket SKTP on the indicating unit Type 33 (this is the plug and socket at the top of the right-hand support tube). Connect the plug to the appropriate socket attached to the test oscillator Type 101. Switch on the test oscillator Type 101. Fit the mirror assembly to one of the support tubes on the indicating unit, and adjust the reflecting surface until the c.r.t. window can be seen in the mirror from a position in which the focus coil adjustment screws are easily accessible for setting up.
- (4) Turn up the BRIGHTNESS control until the spot on the c.r.t. is just visible. Unless the focus coil is already correctly positioned, the spot will probably take the form of an unfocused crescent.
- (5) Slacken off the focus coil locking screws, which are adjacent to the screws which actually adjust the position of the coil. There are four adjusting screws, one giving horizontal shift in the N-S direction, one giving hori-

zontal shift in the E-W direction, one giving N-S tilt, and one giving E-W tilt. The horizontal shift screws are accessible through apertures in the side of the top screen, and the tilt screws through apertures in the top of the screen.

(6) Adjust the four screws until the crescent shape disappears and the spot becomes circular ; it will still be unfocused, having a bright centre with a more or less hazy surrounding circle.

(7) Turn down the BRIGHTNESS control, tighten the locking screws associated with the focus coil adjustment screws and switch off the test oscillator. Remove the test oscillator lead and reconnect plug PLP with socket SKTP.

(8) Turn up the BRIGHTNESS control until the spot is just visible, and turn the FOCUS control through its full travel. This adjustment should cause no movement of the spot. (These controls are potentiometers on the bottom casting of the indicating unit.)

(9) Set the FOCUS control to the position of optimum focus, and check that this position is not near either of the limits of adjustment.

#### Centring control

14. Rotate both centring controls (potentiometers between the FOCUS and BRIGHTNESS controls)

and check that a movement of the spot, of not less than 2 cm., is obtained in each direction. Then adjust so that the spot is exactly in the centre of the c.r.t. screen, as indicated by the small circle on the perspex window.

#### *Timebase ranges*

15. The final adjustment of the FOCUS control cannot be made upon a stationary spot, and it is therefore now necessary to run the timebase unit, the procedure being as follows :—

- (1) Turn the BRIGHTNESS control fully counter-clockwise and restore the sync pulse to the timebase unit. Adjust the BRIGHTNESS control until the rotating trace is just visible (the selsyn having been left running, para. 7). Readjust the FOCUS control as necessary to obtain the finest possible trace.
- (2) Inject 10-mile calibration markers from the marker unit (range) Type 27 into socket X1 on the indicating unit (i.e. into the control-grid of the c.r.t.) and adjust the 120-mile range control RV2 on the timebase unit (with a switch SW1 on that unit in the appropriate position) until a trace of the correct duration is obtained.
- (3) Adjust the sweep control RV4 until the trace is slightly more than 3 in. in length. Readjust the 120-mile range control as necessary.
- (4) When satisfactory, disconnect the lead from the marker unit (range) Type 27 at socket X1.

#### *Photo-electric unit, lens unit and video amplifier*

16. When the c.r.t. focus is satisfactory, it is necessary to adjust the optical and video system so that a satisfactory output is obtained. If the output of either head amplifier is inspected upon an oscilloscope Type 13A, the test slide will give a series of pulses as the trace crosses the circles on the slide. The procedure is as follows :—

- (1) Set RV1 and RV2 of the photo-electric unit to give current readings at X1 and X8 of 8mA or to the maximum obtainable if below this value.
- (2) Inspect the outputs at SKT1 and SKT2, using the oscilloscope Type 13A. These will not be equal in amplitude. Adjust the potentiometer on the section giving the greatest output, so bringing the level of the two outputs to equality.
- (3) Set the BRIGHTNESS control to give 1 volt output at each of the output sockets SKT1, SKT2.
- (4) Adjust the appropriate mirror tilting screws until the amplitudes of the chains of pulses as seen on the oscilloscope are approximately constant when the trace is aligned in each of the four quadrants in turn.
- (5) When the optimum positions for the two mirrors have been determined, adjust the brilliance compensation control RV1 on the timebase unit until all pulses on a given trace are of the same amplitude. Check this in each of the four quadrants.

#### **Note . . .**

*Operations (4) and (5) are best carried out by disconnecting the selsyn input at PLA on the bottom casting of the indicating unit Type 33, and then rotating the selsyn drive shaft by hand. This is done by turning the Oldham coupling between the selsyn and the vertical shaft ; this coupling can be reached by removing the inspection cover on the selsyn housing at the bottom of the left-hand support pillar of the indicating unit.*

- (6) The mirror adjustment (4) will change the level of the pulses at SKT1 and SKT2 as set at (3). RV1 and RV2 must therefore be readjusted to give 1 volt output at each socket, increasing the brilliance of the trace if necessary to obtain this level.
  - (7) Check the currents at X2 and X5 on the photo-electric unit after the level has been adjusted. These should not exceed 8mA.
17. Adjust the video amplifying unit as follows :—
- (1) Reduce the c.r.t. brilliance and reconnect PLA on the indicating unit Type 33.
  - (2) Adjust the BRIGHTNESS control to give outputs at SKT1 and SKT2 of approximately 0.75 volt, and ensure that these signals appear at SKT6 and SKT7 on the amplifying unit (video) Type 298.
  - (3) Adjust RV1 and RV2 on this unit to give outputs from the cathode followers V4-V8 and V12-V16 of  $1.0 \pm 10$  per cent (0.9 to 1.1 volt).
  - (4) Reduce the brilliance until the pulses viewed are just limiting.
  - (5) Measure the beam current of the c.r.t. by connecting a test meter Type CT.38 on the 50 microamp range to point X1 on the power unit (EHT) Type 882. This should not exceed 10 microamp.

#### **Functional tests**

18. The following tests are carried out only on the range upon which the marker unit is required to operate, i.e. 120, 240 or 320 miles. These tests are performed in conjunction with a p.p.i. console of the type upon which the map is to be displayed.

19. Switch on the p.p.i. console and allow it to warm up for at least 10 minutes, the output from one of the sockets on the termination panel of the marker unit being fed into the console. Normally this is already effected via the head selector unit associated with the console used for the test. The picture presented on the console should be well-defined and clearly focused. All the lines in the resolution squares should be clearly and separately painted.

#### *120-mile range*

20. The range markers should then be displayed on the console, and the circles derived from the test slide should be made to coincide with them. The centre of the video map pattern should be first set to the centre of the p.p.i. display by means of

the map carriage controls on the lens unit Type 26, the following adjustments being then made on the timebase unit Type 137. Ensure that a trace of slightly more than 3 in. is obtained (adjusting the sweep control RV4 if necessary) then adjust RV2, the 120-mile range control, until the outer rings are coincident. The controls RV2, RV4, and RV5 are to a certain degree interdependent, and several slight adjustments of each in turn may be necessary to obtain optimum results. It may not be possible to adjust the innermost circle (10-mile mark on 120-mile range) to coincide exactly with the appropriate range marker when the optimum setting is obtained, but the remainder should coincide within 1 per cent., i.e. 1 mile on 120-mile range.

**Note . . .**

*The circles on the 12-ring test slide correspond with 10-mile range marks on 120-mile range, and are 20 miles apart on 240-mile range. The 8-ring test slide is used for setting-up the 320-mile range, and the rings are 40 miles apart. On the console, either 5-mile or 10-mile range marks are available, and this must be borne in mind when aligning the marks.*

**21.** When the inner and outer marks are coincident to within the tolerance quoted, check for eccentricity of the two sets of markers. Such eccentricity may be introduced if the origin of the trace on the marker unit is not perfectly centred, and this point should be verified during and after the procedure given in para. 20.

**240-mile range**

**22.** Set the switch SW1 in the timebase unit Type 137 (or 137A) to the 240-mile (or NORMAL) position. Adjust the 240-mile range control RV3 and the sweep control RV4 to give a trace 3 in. in length and 240 miles in duration, by injecting calibration markers into the control-grid of the marker unit c.r.t. as in para. 15(2). Then adjust the BRIGHTNESS control to the point which just gives limiting of the output signals from amplifying unit Type 298 as in para. 17(4). Adjust the brilliance compensation control if necessary. Finally obtain coincidence of range marks as in para. 20-21.

**320-mile range**

**23.** Set the switch SW1 in the timebase unit Type 137A to the L.R. position. Adjust the 320-mile range control RV2 and the sweep control RV4 to give a trace 3 in. in length and 320 miles in duration, by injecting calibration markers into the control-grid of the marker unit c.r.t. as in para. 15(2). Adjust the BRIGHTNESS control and the brilliance compensation control as previously described, if necessary. Finally obtain coincidence of range marks (40 miles between rings) as in para. 20-21.

**24.** On all ranges the picture on the console should be clear and well-defined. All lines in the resolution squares should be clearly and separately painted.

**Preparation for operating**

**25.** Ensure that each of the ten output cathode followers on the amplifying unit (video) Type 298 (i.e. V4-V8 and V12-V16) produce equally good results on the console display.

**26.** Turn down the BRIGHTNESS control and remove the test slides from the lens unit Type 26. Fit into each map carriage the slide which is to be used on the channel concerned.

**27.** Adjust the BRIGHTNESS control until all pulses are just limiting as in para. 17. Then adjust the map carriage controls until the centre of the map is lying exactly in the centre of the display c.r.t. and the "North" mark on the map is directly above it.

**Note . . .**

*Explicit instructions for obtaining true N-S alignment of the map on the p.p.i. cannot be given, since it depends upon the type of console used for display. On console Type 60 or 60A an azimuth ring is fitted, and a North marker signal can be displayed, so that there is no difficulty. These may not be available, however, on other types of console. Without such aids to alignment, the trace on a fixed-coil console can be made to paint a N-S line by removing the horizontal deflection component. While this line is still persistent, restore the rotational scan, display the video map, and adjust the map carriage rotation controls until the map North is in line with the after-glow N-S line.*

**28.** The indicated range of certain selected geographical features on various bearings from the site (previously determined from a suitable map) should be checked on the displayed video map, by comparison with the range marker calibration. To do this the video map should first be displayed on the p.p.i. to leave an afterglow picture and then removed, the console range marks (calibrator) being then switched on instead.

**Changing the c.r.t.**

**29.** Although not strictly a part of the setting-up procedure, the following information is included here to facilitate reference in the event of a tube failure being discovered when bringing an equipment into service after a period of disuse.

- (1) Ensure that the power supply is disconnected at PLL on the termination panel.
- (2) Momentarily earth the c.h.t. terminal on the c.r.t. with the earthing stick provided, to ensure that no charge remains. Then remove the anode cap of the valve, and the valve base connector from the c.r.t. base.
- (3) Slacken off and remove the clamp round the neck of the c.r.t.
- (4) Slacken off the knurled lock-nut, and the knurled screws, near the bottom of the lower c.r.t. screen; this screw secures the outer locking ring which holds the tube face.

(5) Turn the outer locking ring (complete with inner locking ring) through about 90 deg., so releasing the bayonet joint between the c.r.t. screen and the locking ring. The pressure of the spring-loaded upper seating ring will tend to force the tube downwards as soon as the joint is free to disengage. Then gently lower the locking ring, together with the perspex window and the c.r.t. standing upon it. As soon as the window is below the level of the lower edge of the mu-metal screen, grasp the flare of the c.r.t. firmly with the first and second fingers of each hand, while holding the locking ring between the thumbs and remaining fingers.

(6) Keeping the c.r.t. vertical, lower it (still held upon the window) until the stem is clear of the deflection coil assembly. Holding both c.r.t. and ring firmly, with the c.r.t. standing upon the window, cant slightly to allow the tube to be withdrawn over the top of the lens unit.

(7) The tube should be placed immediately in its crate, if available, otherwise stood upright upon its face, preferably in a corner, and suitably protected to prevent damage.

**30.** To replace the c.r.t., proceed as follows:—

(1) Before fitting, the glass round the anode cap of the valve must be greased with silicone grease for an area of about 1 in. radius all round. No grease other than that specified may be used for this purpose. The object is to eliminate corona effects in the vicinity of the anode cap.

◀(2) Slacken off the inner locking ring, which holds the perspex window with its recessed side uppermost, until it is held only by three or four turns of the thread. ▶

(3) Stand the c.r.t. upon the window, and lift the tube and locking ring assembly together, grasping the ring with the thumbs and fourth fingers of each hand, and the flare of the tube with the remaining fingers. The anode cap should be towards the body, so that it will face the aperture in the mu-metal screen when inserted.

(4) With the indicating unit turned fully back from the cabinet, lift the locking ring, with the tube held upon it as above, and cant slightly so that the c.r.t. can be lifted over the lens unit and its stem inserted into the mouth of the deflection coil assembly. This is done from the right-hand side of the indicating unit, i.e. that which faces the inside of the cabinet.

(5) When the locking ring touches the inner fixed ring of the bayonet joint, rotate slightly as required until it is felt that the joint can be engaged, then engage and turn through 90 deg. to lock it. The outer locking ring should then be immediately secured by the knurled locking screw and lock-nut, care being taken that the locking screw engages

with the slot cut for this purpose in the locking ring.

(6) Support the tube and window in one hand, pressing the flare of the tube against the upper seating ring.

(7) Check that the anode cap of the tube is accessible through the aperture provided, for the attachment of the anode cap, without any tension on the lead, and no strain on the anode cap. This type of c.r.t. is somewhat vulnerable at this point, and great care is necessary to avoid any strain upon the cap. Do not, as yet, fit the anode cap.

(8) Support the perspex window and tube ring, screwing up until there is a gentle pressure between the flare of the tube and the upper seating ring. The springs holding the latter should not however be placed in extreme compression.

(9) Fit the anode cap on the tube, noting the precautions in (7).

(10) Set up the clamp on the stem of the tube and replace the valve base cap VI.

**31.** It will be necessary to check over the setting-up procedure (para. 8-27) on all points in which the c.r.t. itself is concerned. The power units, lens unit, and video amplifier should not be affected by the change; slight readjustments may be necessary to the photo-electric unit and indicating unit controls.

### Optical focus

**32.** The lens unit is set up for optimum focus during its final tests at the maker's works, and as this is not very critical it is rarely necessary to refocus. Accordingly, this should not be undertaken unless the lens unit has been removed from the support tubes for some reason, or unless a serious deterioration of performance throws suspicion upon the optical focus.

**33** The lens unit is held upon the support tubes by collars surrounding the tubes; these collars are secured in the position of optimum focus by nuts and bolts. When the latter are slackened off, the lens unit can be moved up or down the support tubes for focusing purposes by the focusing screw. The latter has a large finger-fluted knob, and passes upwards through the bottom casting of the indicating unit, being secured in the optimum focus position by a holding nut and a lock-nut, the lens unit being then held firmly in this position by tightening the nuts on the bolts holding the collars on the support tubes.

**34.** If there is reason to suspect the optical focus, focusing is carried out as detailed in the following paragraphs. It is not necessary to check the focus of both maps, since the design is such that both are focused simultaneously, but test slides should be inserted in both map carriages, because if the photo-electric unit and/or lens unit are in fact out of adjustment, one map may at the outset be the better of the two and will require less time to bring the optimum focus.

Also, both test slides will be required in the overall check which must follow upon refocusing.

35. The procedure is as follows :—

- (1) Check over the initial setting-up procedure as laid down in para. 9-15, to ensure that the electrical conditions are suitable for correcting the optical focus.
- (2) Set RV1 (or RV2) of the photo-electric unit to give a current reading at X1 (or X8) of 8mA or to the maximum obtainable if below this value.
- (3) Disconnect the selsyn input by removing PLA on the indicating unit Type 33.
- (4) Turn the selsyn by hand (para. 16, Note to operation (5) refers) until the c.r.t. trace is cutting perpendicularly across the lines on one of the fine-resolution squares. Inspect the output of the photo-electric unit at SKT1 (or SKT2) on oscilloscope Type 13A. This should be set to 0.75 volt, or to the maximum if below this figure. If both outputs are low with adequate c.r.t. brightness, mirror adjustment may be necessary (para. 16).
- (5) Apply the above output to SKT5 (or SKT6) on the amplifying unit (video), and inspect the output of the latter on the oscilloscope. Adjust the output to approximately 1 volt by RV1 (or RV2), and then reduce the c.r.t. brightness until the pulses on the oscilloscope are just limiting.

36. As the trace sweeps across the test slide, it passes from the centre cross over four 10-mile range rings, and then over the numerous lines in the fine resolution square, after which it sweeps over five 10-mile range rings. The output from the video amplifying unit should be a clear and well-defined pulse for each range ring, with a number of very closely spaced pulses while the resolution square is being swept. If the focus is incorrect, the portion of the picture corresponding with the resolution square will be an approximately

square wave with short, closely-spaced pulses along the top, as shown in fig. 2(a). When the focus is correct, the appearance of the pulses on the oscilloscope should be somewhat as shown in fig. 2(b), i.e. the fine, closely-spaced pulses due to the resolution lines should rise directly from the base line.

37. If the focus is not sufficiently sharp, it should be adjusted as follows :—

- (1) Slacken off the nuts on the optical focusing screw.
- (2) Slacken off the nuts on the bolts holding the lens unit on the support tubes.
- (3) Raise or lower the whole lens unit by means of the focusing screw while viewing the picture on the oscilloscope. When the bases of the fine pulses descend so that they break out from the baseline of the trace as in fig. 2(b), lock the focusing screw and the side nuts on the support tubes.
- (4) Ensure that the focusing screw holding nut and lock-nut, and the nuts on the support tube brackets, are fully tightened.

38. It is possible that the picture on the oscilloscope, when inspecting the output of the photo-electric unit at SKT1, may be of low amplitude owing to incorrect potentiometer adjustment, or to bad mirror alignment. In this event, the output from SKT2 may be tried. If neither is of use for optical focusing, it will be necessary to adjust the mirrors as described in para. 16 before obtaining a final optical focus, the optimum results being obtained by performing the operations in para. 16 and para. 36 alternately, until the correct picture is obtained.

39. In any event, when the focus is satisfactory, the whole of the procedure described in para. 16-28 should be carried out on both video map channels before reporting the marker unit as ready for operational use.

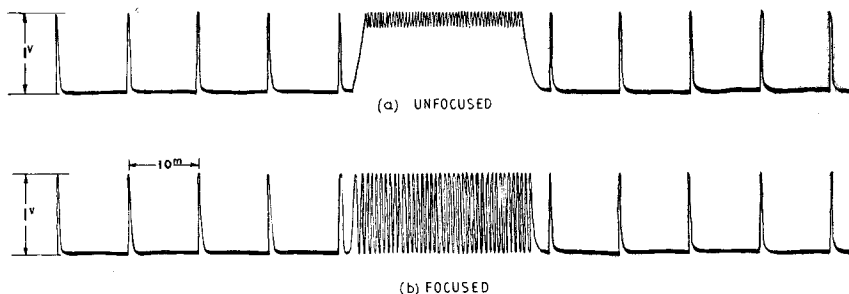

Fig. 2. Test slide pattern waveforms on oscilloscope Type 13A

**PART 2**  
**TECHNICAL INFORMATION**

**LIST OF CHAPTERS**

Note. — *A list of contents appears at the beginning of each chapter.*

- 1 Cabinet and cabling. Appendix 1, Cabinet electrical equipment 5975-99-954-8498.
- 2 Indicating unit (CRT) Type 33.
- 3 Lens unit Type 26 and Photo-electric unit Type 100.
- 4 Amplifying unit (video) Type 298. Appendix 1. Amplifier video 5840-99-946-7733.
- 5 Timebase units Type 137 and 137A. Appendix 1. Generator sweep 5840-99-954-8363.
- 6 Power units (-300V) Type 884 and (+300V) Type 885.
- 7 Switch unit Type 504.
- 8 Power units (EHT) Type 882 and (MHT) Type 883.

## Chapter 1

## CABINET AND CABLING

## LIST OF CONTENTS

	<i>Para.</i>
<i>Construction</i> ... ..	1
<i>Cabling</i> ... ..	7

## LIST OF ILLUSTRATIONS

	<i>Fig.</i>
<i>Marker unit, rear view of cabinet</i> ... ..	1
<i>Marker unit with indicating unit swung back</i> ... ..	2
<i>Main cable-form details</i> ... ..	3

## ◀ LIST OF APPENDICES

	<i>App.</i>
<i>Cabinet electrical equipment 5975-99-954-8498</i> ...	1 ▶

**Construction**

1. The two types of marker unit (video map), Type 30 and Type 30A, are basically similar. The extra-long-range version, Type 30A, is fitted with a modified timebase unit Type 137A instead of the normal timebase Type 137. For certain applications a special repeater amplifier is required. Where this special amplifier is required the cabinet of the video map, complete with wiring, has been identified as a 'cabinet electrical equipment, Ref. No. 5970-99-970-2307.' The marker unit is completely enclosed in a steel cabinet approximately 7 ft. high, 23½ in. wide, and 21 in. deep, which totally encloses the equipment. Two doors are provided, one at the front and one at the rear of the cabinet, to permit easy inspection or adjustment of the unit. An indicating lamp is fitted on each side, above the door; these lamps glow when the power supply to the e.h.t. unit is completed.

2. The mechanical arrangement within the cabinet divides the unit into two parts, viz. (a) the scanning assembly and (b) a rack at the rear of the unit containing the ancillary units. The scanning assembly includes the whole of the optical system, i.e. the lens unit Type 26 and photo-electric unit Type 100, bolted together and mounted on the support tubes of the indicating unit (c.r.t.) Type 33.

3. The rack containing the ancillary units is behind the scanning assembly when looking at the unit from the front door. These ancillary units are made up of simple vertical panels, with handles on each side, which are mounted vertically one above the other; each is secured to the rack by four fixing bolts.

4. The components of the various units are fixed directly on to these panels or on the insulated tag-panels mounted on the unit, whilst the valves of the units are mounted on the other side of the vertical panel. The individual units are mounted in the rack in such a manner that their components are accessible by opening the rear door of the cabinet (*fig. 1*). The interconnection of these ancillary units is mainly effected by means of Jones plugs and sockets, the sockets being part of an inter-unit cable-form. In addition, separate coaxial connectors are used where required, e.g. for the deflection and brightening pulse waveform, the sequence from top to bottom of the rack being as follows:—

- (1) Power unit (e.h.t.) Type 882
- (2) Timebase unit Type 137 (or 137A)
- (3) Amplifying unit (video) Type 298
- (4) Power unit (m.h.t.) Type 883
- (5) Power unit (−300V) Type 884
- (6) } Power units (±300V) Type 885
- (7) } suppling units (1), (2) and (3)
- (8) } above.

5. This arrangement within the cabinet is designed to give easy access to any part of the equipment, particularly the scanning assembly. The indicating unit framework is attached to the left-hand side of the front of the cabinet by hinges which allow the whole assembly to be swung out from the cabinet for the changing of map-slides, replacement of the cathode-ray tube, or any other servicing or adjustment which may be required. The assembly may be swung out whilst the equipment is in use, without affecting its operation in any way; it is retained in this position by a spring-loaded catch

## RESTRICTED

(fig. 2). The front of the ancillary units (the side of these units upon which the valves are mounted) is also made accessible in this way.

6. The hinges by which this assembly is fixed to the cabinet have been specially designed to give a certain amount of flexibility. Distortion of the cabinet for any reason (such as damage during transport) does not affect the indicating unit

framework. It is important that no distortion of this frame should occur under any circumstances since it would seriously affect the working of the optical system. To permit the frame to be swung out to the left of the cabinet, the front door is hinged on the right-hand side.

### Cabling

7. All input and output leads to this equipment

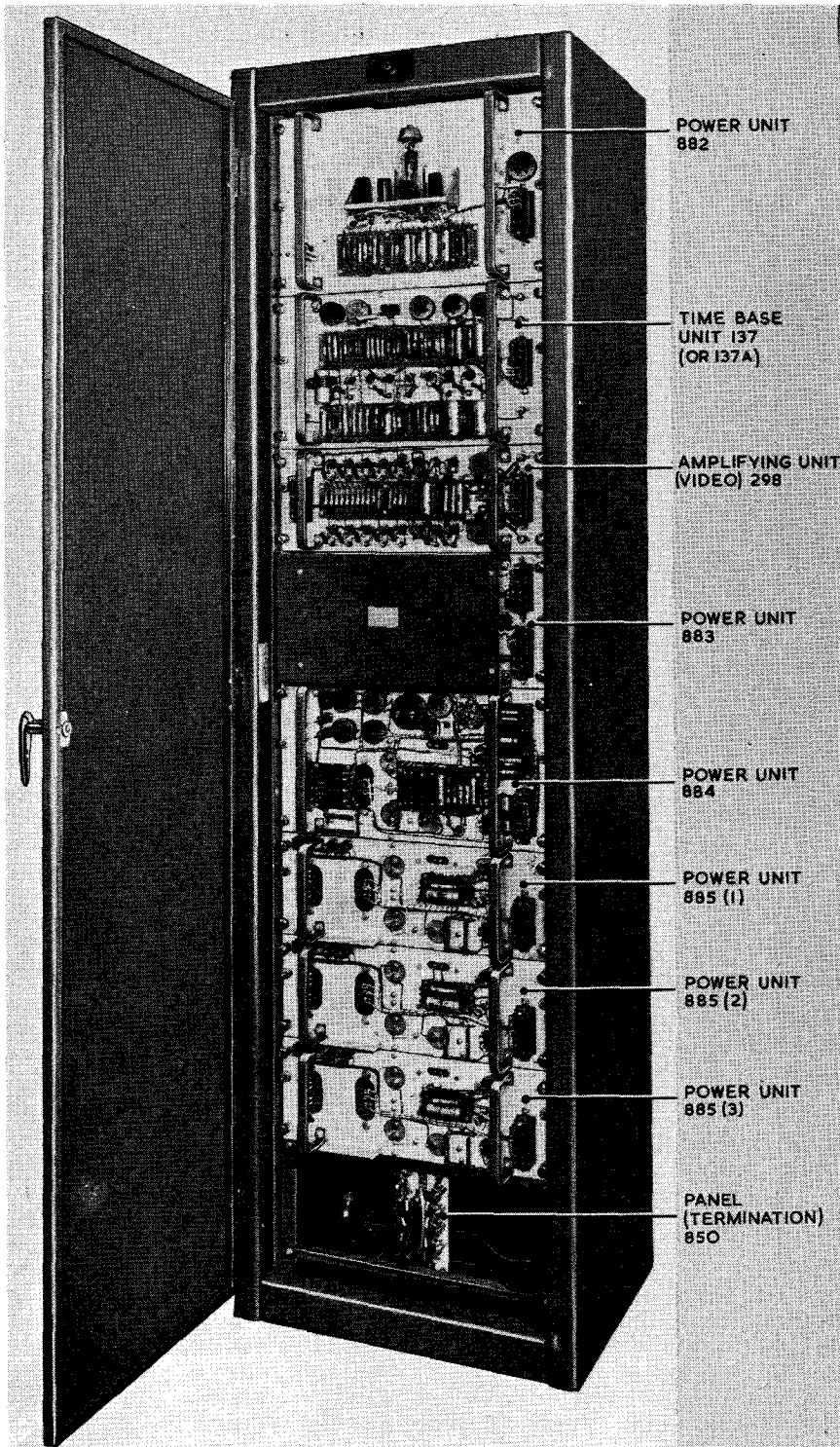
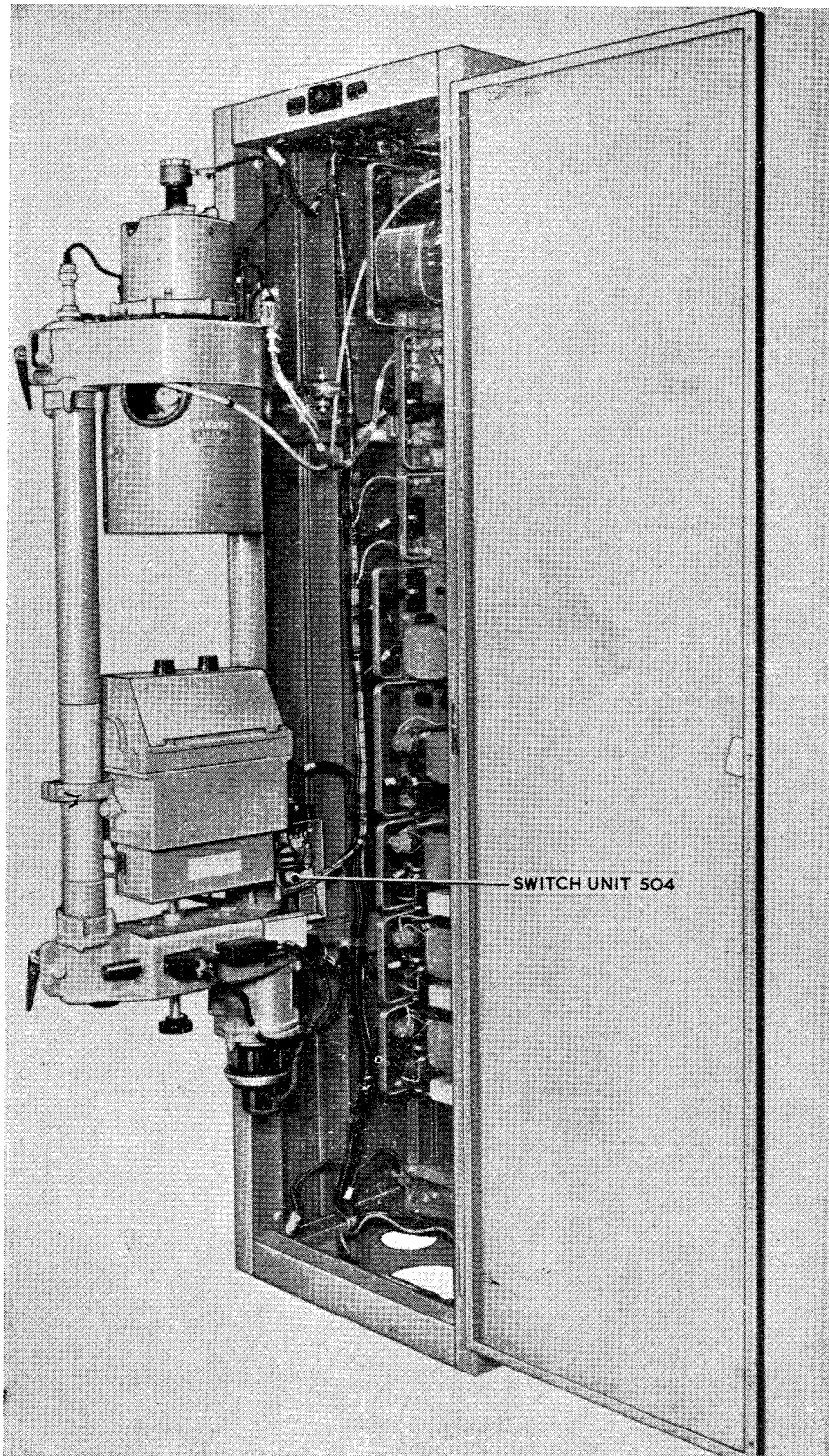

Fig. 1. Marker unit, rear view of cabinet

RESTRICTED



**Fig. 2. Marker unit with indicating unit swung back**

are brought to a small panel (panel termination Type 850) which is normally bolted to a pair of horizontal strips at the foot of the rack, below the ancillary units (*fig. 1*). This panel is movable so that if required it may be passed, with its associated leads, through holes provided in the base of the cabinet and taken to a similar video mapping unit.

In this way, when more than one marker unit Type 30 is being used, all ingoing and outgoing leads may be dealt with in the cabinet of one selected equipment by transferring the respective connector panels to that equipment. This simplifies the change-over of units should one unit require examination or servicing.

**RESTRICTED**

8. The termination panel carries one Jones plug, coded PL.L, and eleven sockets Type 783 (Stores Ref. 10H/19861) coded SK.12 to SK.22. The main cable-form originates upon this panel and is taken up the left-hand side of the front part of the cabinet in metal clips as shown in fig. 2, and terminates upon PL.D on the amplifying unit (video) Type 298. Between these points branches are taken as necessary to the three plugs PL.K on the first, second and third power units Type 885, to PL.B on the lower casting of the indicating unit framework, PL.M on the photo-electric unit, PL.N on the switch unit Type 504, PL.J on the power unit Type 884, PL.H and PL.G on the power unit Type 883, PL.C and PL.D on the amplifying unit (video) Type 298, PL.E on the timebase unit Type 137, and PL.F on the power unit (EHT) Type 882.

9. Various inter-connections between sockets Type 783 are also carried in this cable-form, i.e. PL.1 to PL.6 and PL.2 to PL.7, for the two video map outputs from the photo-electric unit to the video amplifying unit, and PL.12 to PL.11 for the sync input to the timebase unit. Ten coaxial leads carry the two multipole video outputs from PL.D on the amplifying unit to the termination

panel ; these terminate at SK.13-SK.17 for MAP 1, and at SK.18-SK.22 for MAP 2.

10. Earth leads are included in the cable-form, and these are connected to four separate earthing points at different levels on the cabinet. Some of these leads run between the different earthing points in order to provide low-impedance paths independent of the cabinet itself. Others are leads from chassis to earth.

11. The main cable-form connects with the indicating unit interior cable-form at five points. These connections (T1 to T5) are made upon a terminal board near the switch unit Type 504.

12. Details of the length of all cables in the cable-form are given in Table 1. Fig. 3 is a working diagram of the cable-form itself, and is intended for use in the event of any defects occurring. Sufficient information is given in this diagram and Table 1 to enable the cable-form to be stripped and re-made after repair. If this becomes necessary care should be taken to clip the cable-form in the original route ; all the various earth leads must be reconnected, otherwise noise or jitter may appear on the video output.

TABLE 1

Cable-form details

Connection	From	To	Length (in.)	Service
40/0076	LA1/1	LA2/2	44½	Pilot lamp
40/0076	LA1/2	LA2/2	44½	Pilot lamp
40/0076	LA2/3	K3/1	94	Pilot lamp
40/0076	LA2/4	K3/2	94	Pilot lamp
TELCON K.16	D.1	SK.18	217	Map 2, output
TELCON K.16	D.2	SK.19	217	Map 2, output
TELCON K.16	D.3	SK.20	217	Map 2, output
TELCON K.16	D.4	SK.21	217	Map 2, output
40/0076	D.5	Earth clip	1¼	Earthing
TELCON K.16	D.6	SK.22	217	Map 2, output
TELCON K.16	D.7	SK.13	217	Map 1, output
40/0076	D.8	Earth clip	1¼	Earthing
TELCON K.16	D.9	SK.14	217	Map 1, output
TELCON K.16	D.10	SK.15	217	Map 1, output
TELCON K.16	D.11	SK.16	217	Map 1, output
TELCON K.16	D.12	SK.17	217	Map 1, output
40/0076	Earth clip	E1/2	35	Earthing
UNIRADIO 70	PL.11	SK.12	212	
40/0076	E1/1	E2/1	32½	Interconnecting earths
40/0076	E2/2	E3/1	20	Interconnecting earths
40/0076	E3/2	E4/1	96	Interconnecting earths
40/0076	E3/3	F.12	22	EHT unit earth
40/0076	E3/4	E.12	32½	Time base unit earth
40/0076	E3/5	C.12	40½	Video amplifier earth
40/0076	E3/6	G.12	46½	MHT unit earth
40/0076	F.1	J.4	53	+300V from K3

RESTRICTED

TABLE 1

Cable-form details—*continued*

Connection	From	To	Length (in.)	Service
40/.0076	F.5	G.7	41	} 6.3V to V1, V2, V3, P.U.882
40/.0076	F.6	G.8	41	
40/.0076	F.3	G.1	41	} 6.3V to V6, P.U.882
40/.0076	F.4	G.2	41	
40/.0076	F.11	E.11	25	-300V
40/.0076	F.11	G.11	41	-300V
40/.0076	E.1	J.3	45	+300V from K1
40/.0076	E.7	G.5	28½	} 6.3V to V6, T.B.U.137
40/.0076	E.8	G.6	28½	
40/.0076	E.9	G.9	28½	} 6.3V to all valves except V6, T.B.U.137
40/.0076	E.10	G.10	28½	
40/.0076	E.11	C.11	22½	-300V
40/.0076	C.1	J.5	34½	300V from K2
No lead bears this number				
40/.0076	C.5	H.5	26	} 6.3V to V1-V8, A.U.298
40/.0076	C.6	H.6	26	
40/.0076	C.9	H.7	26	} 6.3V to V9-V16, A.U.298
40/.0076	C.10	H.8	26	
UNIRADIO 70	PL.6	PL.1	60	P.E. unit video to vid. amp. Map 1
UNIRADIO 70	PL.7	PL.2	56	P.E. unit video to vid. amp. Map 2
40/.0076	G.3	J.7	28½	Grid V4
40/.0076	G.4	J.3	28½	+300V
40/.0076	G.11	J.11	28½	-300V
40/.0076	H.1	J.1	24	230V supply
40/.0076	H.2	J.2	24	230V supply
40/.0076	H.3	B.5	64	} 6.3V to V2 (focus valve)
40/.0076	H.4	B.6	64	
40/.0076	H.9	B.7	64	} 6.3V to V1 (CRT)
40/.0076	H.10	B.8	64	
40/.0076	H.7	M.5	45	} 6.3V to V2, V4, V6, V7, P.E.U.100
40/.0076	H.8	M.6	45	
14/.0076	MHT. 1	MHT. 2	50	MHT supply to P.E. unit
40/.0076	J.1	K1.1	21	230V
40/.0076	J.2	K1.2	21	230V
40/.0076	J.3	K1.9	20½	+300V to J.3
40/.0076	J.4	K3.9	35½	+300V to J.4
40/.0076	J.5	K2.9	29	+300V to J.5
40/.0076	J.6	M.9	38	Bias regulation
40/.0076	J.8	K2.11	28½	-300V to K2
40/.0076	J.9	K3.11	35½	-300V to K3
40/.0076	J.10	K1.11	21	-300V to K1
40/.0076	J.11	B.11	51¼	-300V to indicator, centring
40/.0076	J.12	E4/2	48	Earthing
40/.0076	N.1	K3/7	44	230V
40/.0076	N.2	K3.8	44	230V
40/.0076	N.3	K3.1	44	} 230V from Switch Unit 504
40/.0076	N.4	K3.2	44	
40/.0076	N.6	K2.9	35	+300V to RL.1
TELCON K.16	N.10	B.3	60	} Relay contact, CRT cathode
TELCON K.16	N.11	B.4	60	
40/.0076	N.12	E4/5	54	Earthing
40/.0076	M.1	K2.9	45	+300V HT supply
40/.0076	M.11	B.11	66¼	-300V
40/.0076	M.12	E.12	66¼	Earthing

TABLE 1

Cable-form details—continued

Connection	From	To	Length (in.)	Service
40/.0076	K1.1	K2.1	24	230V
40/.0076	K1.2	K2.2	24	230V
40/.0076	K2.9	B.1	44	+300V centring and brill. control
40/.0076	K.12	E4/1	42	Earthing
▶ 40/.0076	B.9	L.9	131½	} Auto-align relay
40/.0076	B.10	L.10	131½	
40/.0076	N.12	E4/5	61½	Earthing
40/.0076	TB1/1	L1	103	} Selsyn rotor A1, A2
24/0.2	TB1/2	R1	A/R	
40/.0076	TB1/3	L3	103	} Auto-align contacts
40/.0076	TB1/4	L4	103	
40/.0076	TB1/5	L5	103	Selsyn stator F
24/0.2	TB1/6	R1	A/R	Selsyn rotor damping ◀
40/.0076	K2.1	K3.7	22	230V
40/.0076	K2.2	K3.8	22	230V
40/.0076	K2.12	E4/6	36	Earthing
40/.0076	K3.7	L.7	98	Mains in
40/.0076	K3.8	L.8	98	Mains in
40/.0076	K3.12	E4/7	28	Earthing
40/.0076	E4/8	L.12	91	Earthing

Note...

The following leads are not included in cable-form:

Timebase unit SK.8 to indicator SK.3, Deflection waveform 1.

Timebase unit SK.9 to indicator SK.4, Deflection waveform 2.

Timebase unit SK.10 to indicator SK.5, brightening pulse.

Power unit EHT Type 882, OUTPUT to indicator CRT cap.

▶ Wiring between TB1 and R1. ◀

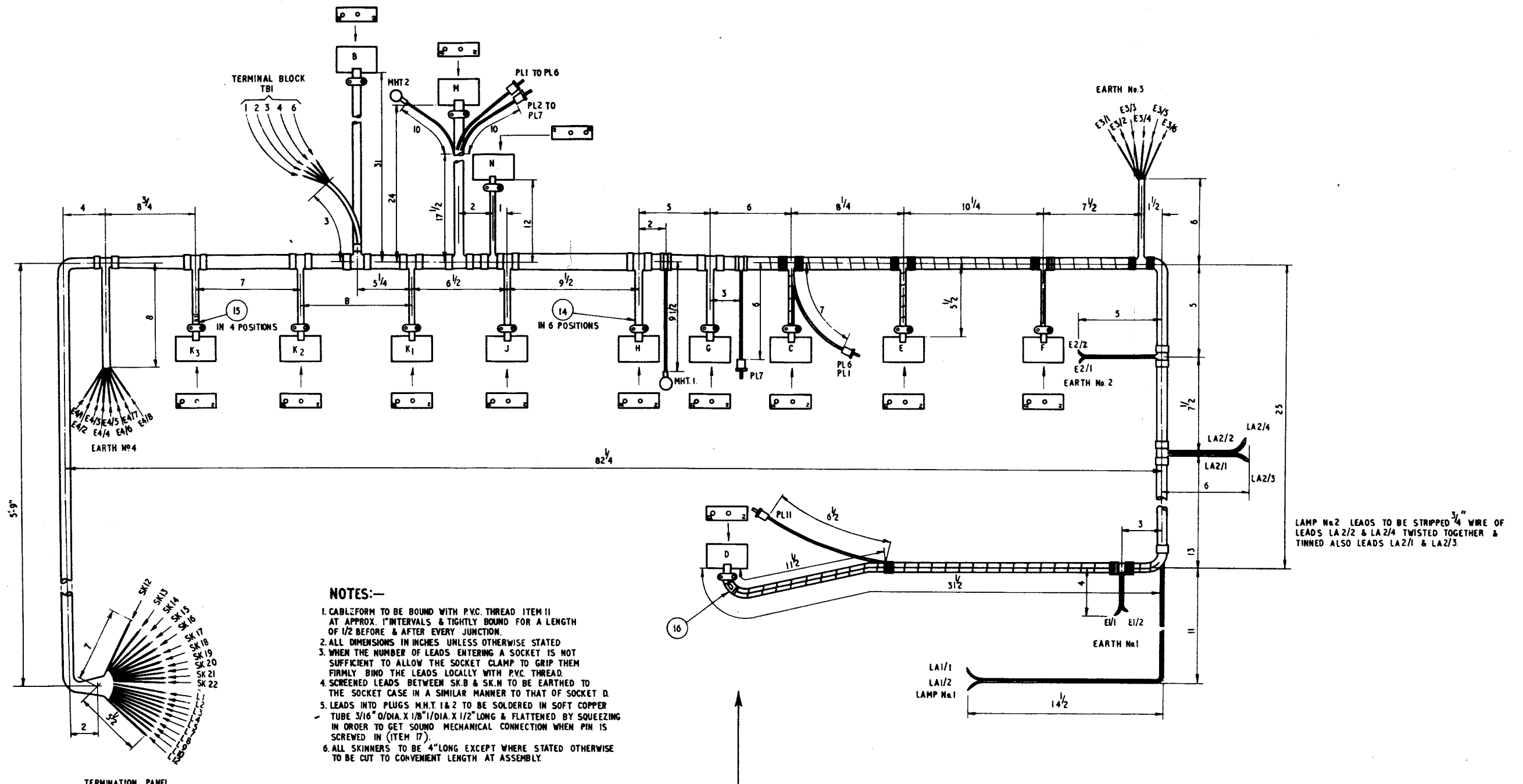

LEADS SK.12 TO SK.22 TO BE TERMINATED AS SHOWN IN FIG. 2. EARTH LEADS TO BE STRIPPED BACK AS SHOWN AT 3" TWISTED IN BANKS OF THREE & THEN TINNED. ALL OTHER LEADS STRIPPED BACK AS AT 1. STRANDED LEADS TO BE TWISTED AND TINNED.

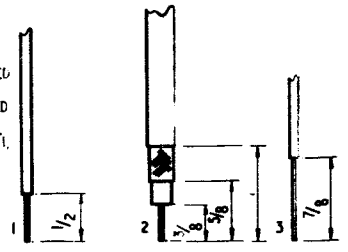

**WIRING OF SOCKET D:-**

1. BRAID EXPOSED FOR 2 1/2"
2. BRAID FORMED INTO PIGTAIL
3. POLYTHENE STRIPPED FROM CONDUCTOR FOR 3/8"
4. OUTER CASING REPLACED & CONDUCTOR SOLDERED IN POSITION.
5. BRAIDS, TOGETHER WITH THE TWO SHORT EARTH LEADS (OS & DB) & LEAD TO E1/2 BOUND NEATLY TOGETHER WITH 25 S.W.G. TINNED COPPER WIRE & SECURELY SOLDERED. ALL CABLES THEN BOUND TIGHTLY TOGETHER, USING THE 25 S.W.G. WIRE IN SUCH A POSITION THAT THE CLIP OF SOCKET CLAMPS TIGHTLY OVER THE WIRE AS SHOWN IN 6.

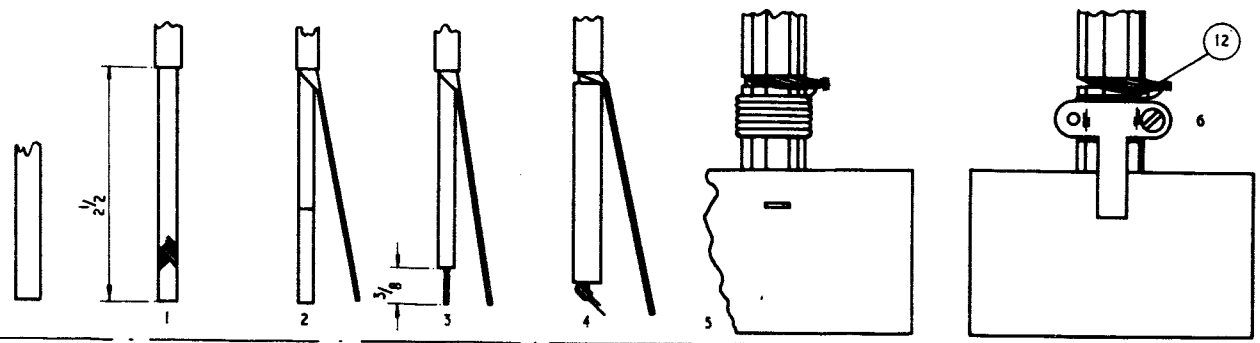

Fig. 3  
Feb. 80 (Amdt. 19)

Main cable-form details  
RESTRICTED

Fig. 3  
Chap. I  
Page 7/8

**Appendix 1**

**CABINET ELECTRICAL EQUIPMENT**

**5975-99-954-8498**

**CONTENTS**

	<i>Para.</i>
<b>Introduction</b> ... ..	... 1
<i>Panel termination</i> 5840-99-954-8501	... 2

**INTRODUCTION**

1. The cabinet electrical equipment 5975-99-954-8498 is similar to the marker unit (video map) 30A with the following changes. The panel termination assembly 850 is replaced by the panel termination 5840-99-954-8501 and the timebase unit 137A replaced by the generator sweep 5840-99-954-8363. Details of the generator sweep 5840-99-954-8363 are given in Part 2, Chap. 5, Appendix 1.

**Panel termination 5840-99-954-8501**

2. The panel termination 5840-99-954-8501 is a panel termination assembly 850 as detailed in Chap. 1, modified by the fitting of a socket SK24. When used in the C.E.E. 5975-99-954-8498 the cabinet cableform, connects SK24 to SK23 on the generator sweep.

## Chapter 2

### INDICATING UNIT (CRT) TYPE 33

#### LIST OF CONTENTS

	Para.		Para.
Introductory ... ..	1	Circuit description ... ..	44
Construction		Auto-align circuit ... ..	49
Principal features ... ..	3	Cableforms ... ..	54
Details of assembly ... ..	18		

#### LIST OF TABLES

	Table
Main cableform ... ..	1
PL.P cableform ... ..	2
Miscellaneous connections ... ..	3

#### LIST OF ILLUSTRATIONS

	Fig.		Fig.
Indicating unit, front view ... ..	1	Deflection coil housing and coil assembly ... ..	10
Indicating unit, rear view ... ..	2	Focus, centring, and deflection coil assemblies, exploded view	11
Top of indicating unit... ..	3	Main screening can showing CRT seating and locking rings...	12
Top of indicating unit (upper can removed)... ..	4	Selsyn, selsyn shaft, and bearings ... ..	13
Focus coil removed from body ring ... ..	5	Tag board and cableform prior to fitting ... ..	14
Focus coil, with and without cover plate ... ..	6	Indicating unit Type 33, circuit ... ..	15
Removal of centring coil ... ..	7	Auto-align system, simplified... ..	16
Deflection coil housing exposed ... ..	8	Cableform details ... ..	17
Top casting after removal of deflection coil housing...	9		

**Note.**—Keys to the photographs will be found at end of chapter.

#### Introductory

1. The indicating unit of the marker unit (video map) Type 30 is comparatively simple electrically, since the principal circuits are assembled in other units of the cabinet. The mechanical assembly, however, is somewhat complex. Many of the parts are interchangeable with others of the same type and may be replaced if they become defective; in order to do so, it is necessary partly to dismantle the indicating unit. The photographs illustrating

this chapter are intended as a guide in performing such operations.

2. On first assembly, all ball bearings and cage rings are lightly greased with DTD.825; this grease is also smeared on the inside of each bearing retaining plate to act as a dirt seal. A similar procedure should be adopted in the event of any bearing or bearing cage ring being renewed.

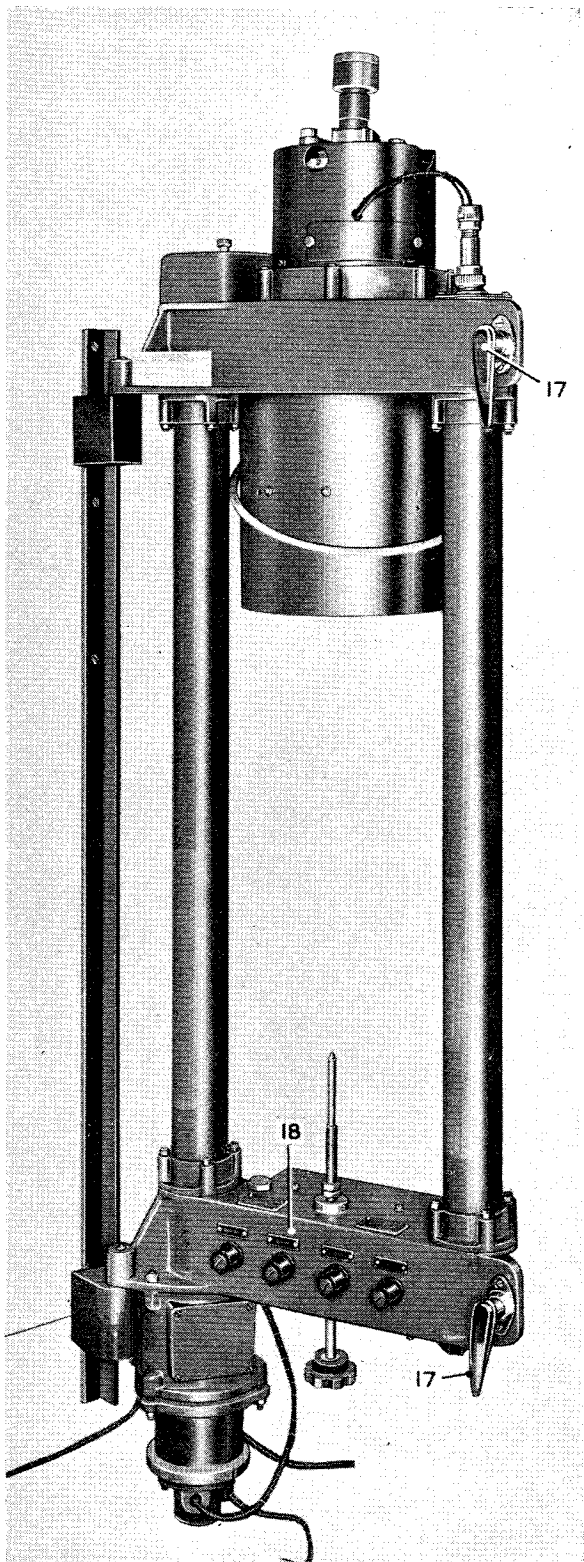

Fig. 1. Indicating unit, front view

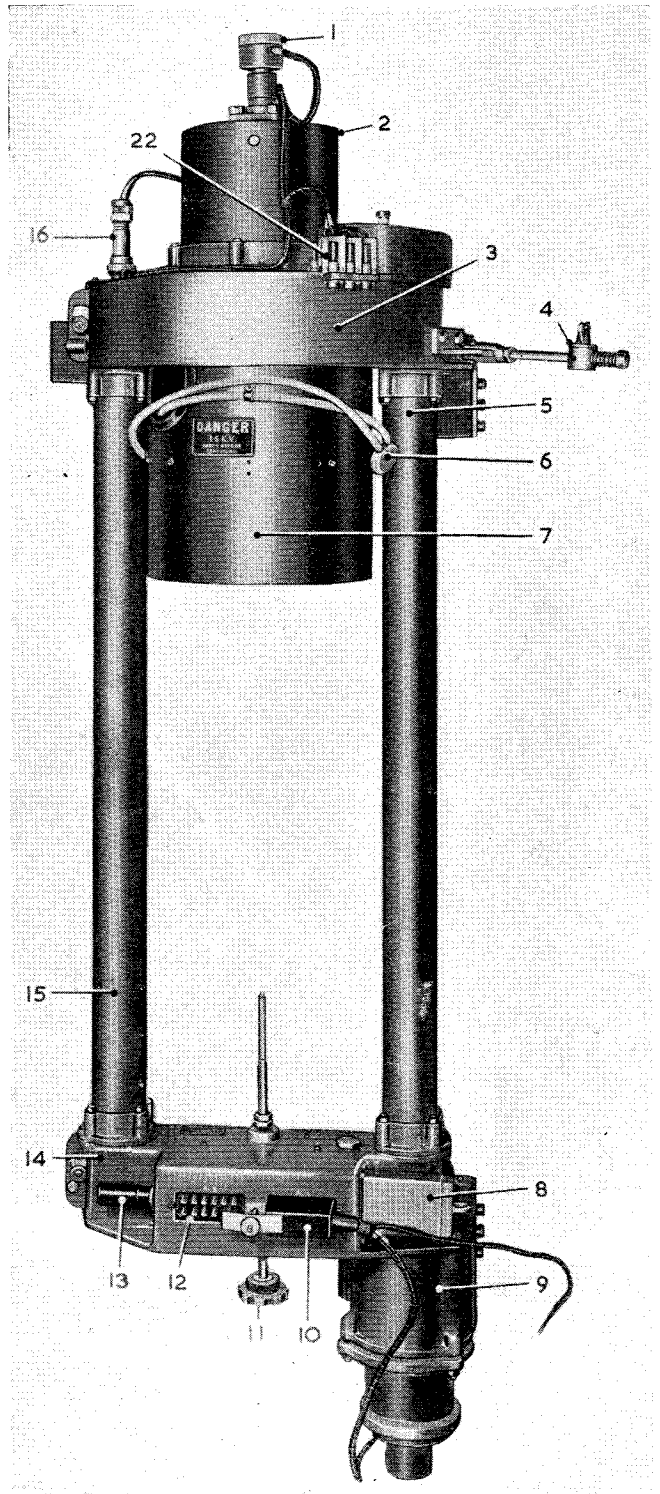

Fig. 2. Indicating unit, rear view

RESTRICTED

## CONSTRUCTION

### Principal features

3. The primary features of the indicating unit will be described with reference to fig. 1 and 2. The overall length is just under 5ft. 6 in., the width is 19 in., and the depth 11 in. It is hinged to the left-hand side of the cabinet as shown in fig. 1, and secured in the operating position by two car-type locking handles (17). These hinges allow the unit to be swung outwards for setting-up purposes, and also to give free access to the other units in the cabinet; a spring-loaded catch (4) is fitted to retain the unit in this position.

4. The standing part of each hinge is attached to the left-hand side of the cabinet; it consists of a bracket inside which is a cup bored out to take the hinge bolt, and having a hemispherical depression on its upper face. The hinge on the indicating unit has a similar but inverted cup. The hinge bolt passes through the two cups, and the weight of the unit is taken upon a hinge ball which is enclosed between the two hemispherical surfaces. A spring clip is fitted to prevent the hinge bolt from falling out when the nuts at the top are removed.

5. The unit consists basically of two light alloy castings, known as the upper casting (3) and the lower casting (14). The upper casting carries the CRT (CV.2897) together with the focus coil Type 100, centring coil, and deflection coil. The deflection coil, together with the final gear wheel of a train of gears by which it is rotated round the neck of the tube, is mounted in a pair (upper and lower) of ball bearings; the upper one, together with the coil itself, the auto-align cam, auto-align contacts, and final gear wheel, are all mounted in a detachable unit known as the deflection coil assembly Type 102, Stores Ref. 10Q/16212.

6. The centring coil is mounted upon an irregularly shaped plate (forming coil assembly centring, Stores Ref. 10Q/16214) which fits inside the upper body ring in such a manner that the lower face of the coil is about  $\frac{1}{4}$  in. clear of the top of the deflection coil; the greater part of its length is therefore inside the end of the tube carrying the upper ball race of the deflection coil. The latter coil is called coil deflecting Type 100, Stores Ref. 10Q/16216.

7. The CRT is mounted vertically in such a manner that its stem passes through the deflection coil, the centring coil, and the focus coil in succession, finally protruding through the top of the upper screening can (2), connection to the heater and cathode of the tube being made through the base contacts, which mate with a standard valve socket marked V1; the latter is attached to one end of the main cable loom. The CRT is secured in this position by a clamp carried upon a removable bracket. The face of the tube seats upon a perspex window carried in a removable ring fitted in the lower part (7) of the CRT screen. When so fitted,

the flare of the tube is held against a flexibly-mounted seating ring carried upon three studs.

8. The focus coil assembly is mounted in two gimbals, the inner gimbal being a ring, in which the coil itself is carried upon two grub screws fitted with lock nuts. This ring in turn is carried by pivots fitted in a stirrup-shaped member which is attached to the inner top plate of the upper body ring. This plate permits the focus coil to be moved in two mutually perpendicular directions, and the gimbals allow the coil to be similarly tilted. The screws by which these focusing adjustments are made are accessible through apertures in the upper screening can.

9. The lower casting (14) carries two Jones plugs PL.A(10) and PL.B(12), the optical focusing screw (11), the auto-align relay (8), the focus control valve (13), and the drive selsyn (9). Two centring controls and focus and brilliance controls, are mounted on the front as shown at (18) in fig. 1. A tagboard carrying the resistors and condensers pertaining to the focusing and centring circuits is housed inside the casting.

10. The upper and lower castings are mechanically connected by the two support tubes (5) and (15) which normally carry the lens unit Type 26 and photo-electric unit Type 100, assembled to make a single unit which can be moved up and down the support tubes for the purpose of optical focusing; the focusing screw (11) is used for this purpose. When the CRT trace is properly focused, the optical assembly is clamped to the support tubes.

11. The selsyn (9) is driven from the transmitter selsyn at the aerial head, the output shaft being connected by an Oldham coupling to a long shaft which is housed inside the left-hand support tube. Access to the coupling is necessary for certain setting-up operations, and is obtained through a rectangular aperture in the selsyn mounting; this is however, normally covered by a plate, as shown in fig. 1.

12. The shaft runs in ball bearings fitted at each end of the support tube, details of which are given later. The upper end of the selsyn drive shaft carries a clamping plate by which the shaft is locked in position during transit; this clamp must always be checked before putting into operation, to ensure that the shaft is free to rotate.

13. Above this plate, the first pinion of the deflection coil drive gear train is fitted. This drives an intermediate gear consisting of a large and a small gear wheel rigidly connected. These are mounted in ball bearings in a separate housing known as the intermediate gear housing, Stores Ref. 10AR/2124. In order to ensure interchangeability of this gear assembly, it is mounted upon a locating ring which is dowelled in position upon the casting. The intermediate gear drives the large

RESTRICTED

wheel forming part of the deflection coil housing, and so turns the deflection coil.

14. Beside the heater and cathode connections for the CRT itself, which are made through the valve cap V1, three sets of electrical connections have to be made to the coils surrounding the CRT neck, viz., the focus coil, centring coil, and deflection coil. In addition, connection must be made to the auto-align cam. Connection to the focus coil, centring coil, and auto-align cam is made through a short cableform connected to the main cableform (which runs through the right-hand support tube) by a plug PL.P(16) mating with a socket SK.P mounted upon the upper casting. This socket is connected to the appropriate leads of the main cableform as described later. The leads from PL.P to the focus coil are connected via a small tag block called TB2, and those for the centring coils via a small tag block called TB3. The leads to the auto-align contacts are connected directly to the contact soldering tags. These contacts are mounted upon a bracket to permit of movement round a small arc

of the travel of the auto-align cam, access to this bracket being obtained through an aperture fitted with a rectangular cover plate.

15. The connections to the deflection coil are made via three coaxial sockets (22) mounted on the top casting; two of these (SK.3, SK.4) carry the timebase waveform from the timebase unit Type 137. The other coaxial socket (SK.5) is used to carry a brightening pulse, also from the timebase unit. A resistor connected to a test point marked X1 is connected to the control-grid of the CRT.

16. When it becomes necessary to dismantle any considerable portion of the assembly carried by the upper casting, it is preferable to lay the indicating unit horizontally upon a table, or upon a wooden trestle especially made up to fit it. This is absolutely necessary if the deflection coil assembly has to be removed, otherwise, when replacing or renewing it, the ball race nips the ball bearings tightly and it is very difficult to fit the item correctly.

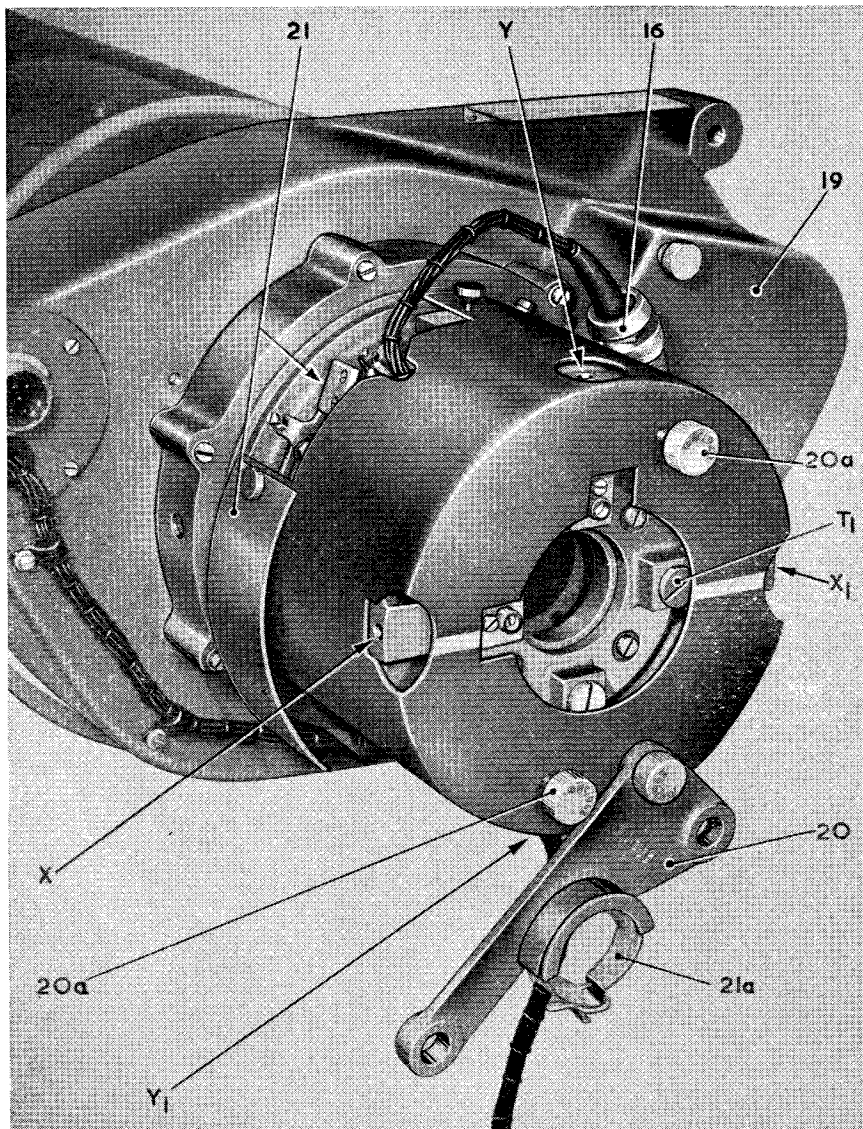

Fig. 3. Top of indicating unit

RESTRICTED

17. When replacing the auto-align cam, care must be taken that the cam ring, fits accurately upon the shoulder of its seating, all the way round, otherwise it becomes tilted and the securing ring cannot be screwed home.

#### Details of assembly

18. Fig. 3 is a top view of the upper portion of the indicating unit, showing the top screening can, and the tube clamp (20) which has been displaced to show the relative position of the tilt screws and focusing screws. In its normal position the tube clamp is swung round and is held on the two knurled screws (20a) in addition to the one by which it is secured in the photograph. ◀ The clamp pads (21a) are impregnated with a conducting substance and are used to ensure a good electrical contact between the graphite coating of the c.r.t. and earth. ▶ The positions and access to the focusing adjustments X, X1, Y, Y1, T, T1,

are shown here ; further reference is made in the following paragraph. The cover plate (21) gives access to the auto-align contacts for adjustment purposes. The gear access cover (19) is secured by captive screws with knurled heads, for ease of access to the gearing and to the gearing clamp.

19. Fig. 4 is a top view of the upper casting and details mounted thereon. The top screening can shown at (2) in fig. 2 has been removed, exposing the top body (27). This is mounted upon the deflection coil housing (28). The small gear wheel (24) is the one at the top of the drive shaft, referred to in para. 2. This drives the large intermediate gear wheel (25a) which is integral with the small gear wheel (25b), and the latter drives the actual deflection coil mounting which is fitted with a final gear wheel (26) it will be observed that a braking plate and clamp (23) are fitted in order to lock the shaft during transit. This clamp must be slackened off when the equipment is in use.

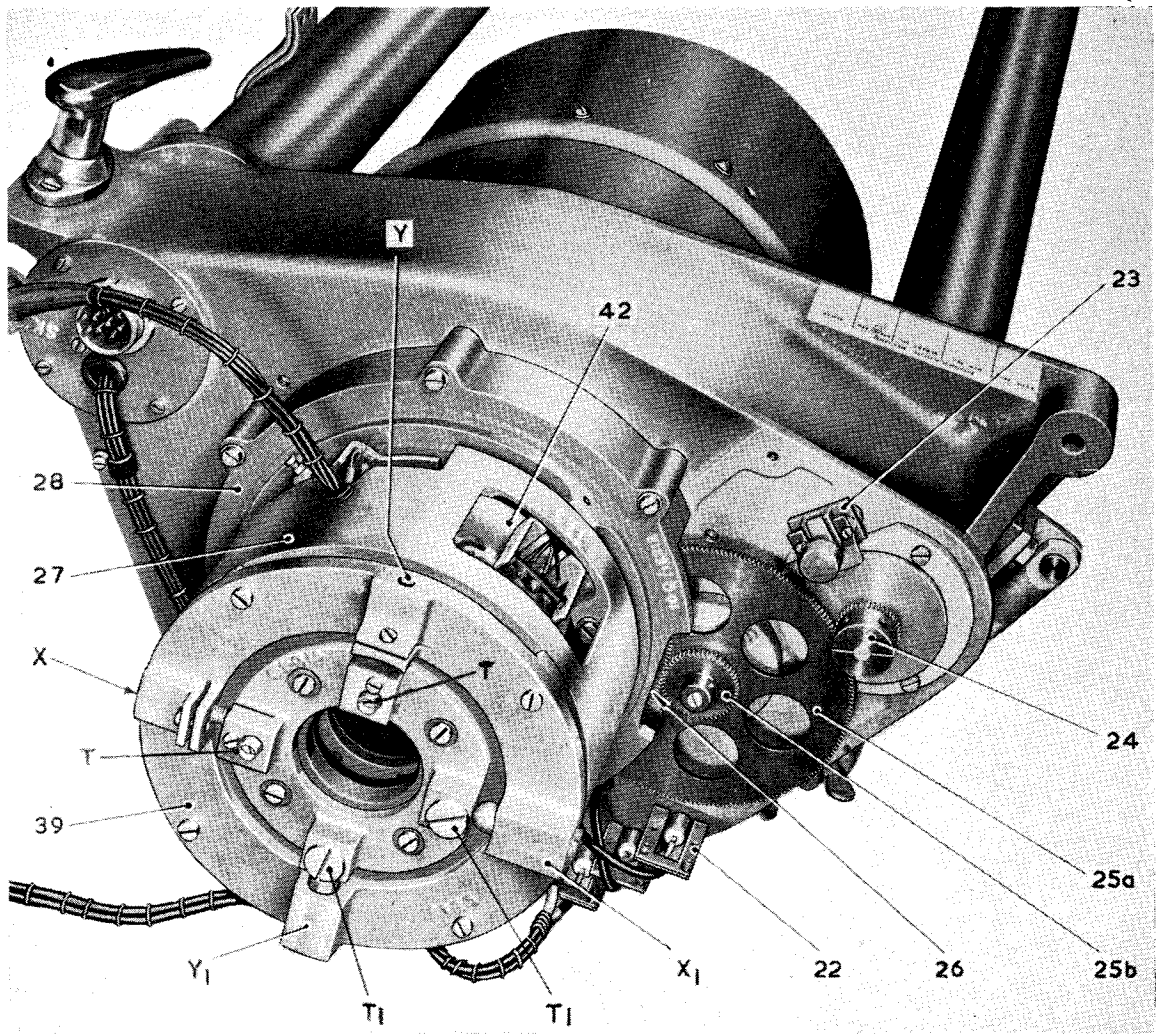

Fig. 4. Top of indicating unit (upper can removed)

**20.** The centring coil is fixed with relation to the central axis of the tube mounting, centring being performed by varying the currents in the north-south and east-west limbs of the coil. The focus coil however slides bodily in two perpendicular directions (N-S and E-W) and also tilts in the same directions. In the E-W direction, the adjustment is made by a set-screw Y, which slides the plate carrying the coil bodily against the action of a spring plunger mounted inside the projection Y1. Similarly, in the N-S direction, the plate is moved by the set screw at X against the spring plunger at X1. Tilt is obtained by the tilt screws T, T1, against the action of spring plungers T1, T1.

**21.** The plate (39) can be detached from the top body ring (27) by removing four screws. The appearance is then as in fig. 5, in which the focus coil (30) mounted in its gimbals has been withdrawn as far as possible without unsoldering the red and black leads from the focus coil tag block TB2 (31). One of the pivots by which the inner gimbal is carried upon the stirrup-shaped bracket is shown at (29). Just above the tag block (31) is one of the

grub screws (with locknut) by which the coil itself is carried by the inner gimbal ring. This view also shows the auto-align contacts and their mounting bracket (31).

**22.** The focus coil proper is mounted inside a light alloy housing 4 in. in diameter, in which it is secured by an end cover plate. The whole assembly is called coil focusing Type 100, Stores Ref. 10Q:16217; if the coil becomes defective, the whole assembly must be renewed.

**23.** When fitted in the unit, the focus coil has a top cover plate having a small hole through which focus coil leads have to pass, before being soldered to the terminal block TB2. This cover plate is not part of the focus coil assembly Stores Ref. 10Q:16217, the appearance of the latter being shown in fig. 6, on the right. It will be observed that the leads are held in place by a small saddle. When a defective focus coil is removed, together with the cover plate, the latter must be fitted to the new coil as shown in the left of fig. 6. The leads are released from the saddle, passed through the

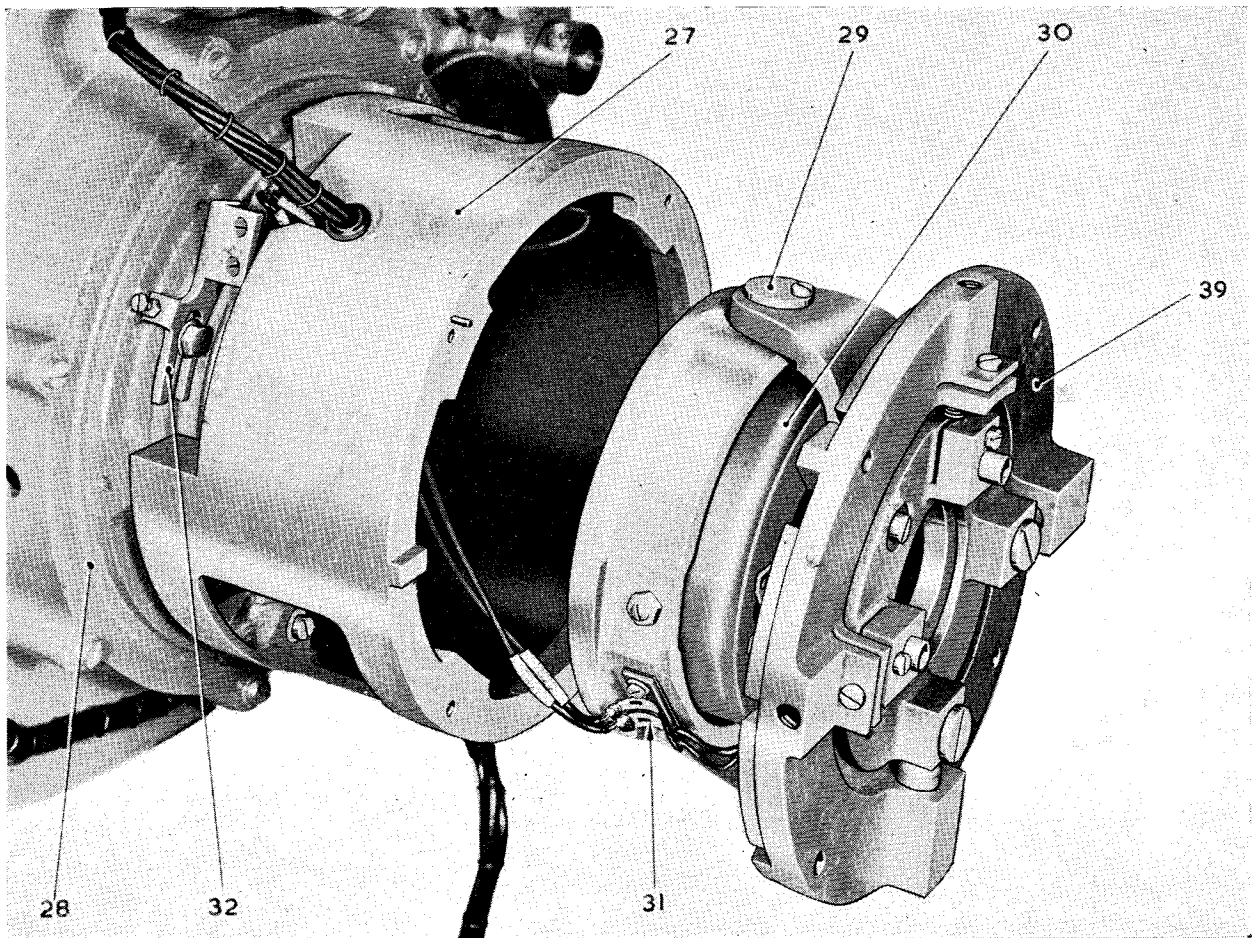

Fig. 5. Focus coil removed from body ring

hole in the plate, and brought up on the inside under the small rectangular guard plate, being finally secured again with the saddle at a suitable angle for attachment to TB2. This is done to prevent the leads being trapped in the outer gimbal.

24. After unsoldering the leads from TB.2, the whole of the top plate with focus coil attached can be entirely removed. This gives access to the interior of the body ring (27). Note that the correct orientation of the top plate with reference to the ring (27) is obtained by a dowel pin which is shown in fig. 7.

25. The plate (33) upon which the centring coil (34) is mounted fits inside the body ring (27), where it is fastened to the lower flange of the body by two studs which pass completely through the ring and engage with threaded holes in the deflection coil housing. This plate also carries the centring coil tag block (34a). After the two studs have been removed, the plate, with coil attached, must be turned through a small angle so that it clears the four lugs which project inwards at the top of the body ring, before it can be completely

withdrawn to the full length of the connecting leads as in fig. 7. The lead marked TB3.4 is from pin C on SK. P, and that marked TB3.6 is from pin D; when reconnecting these leads the former mates with the green lead to the coil, and the latter with the red lead. The black lead from the coil is the earthed one.

26. After the centring coil terminal block has been disconnected, the centring coil sub-assembly can be entirely removed, the appearance then being

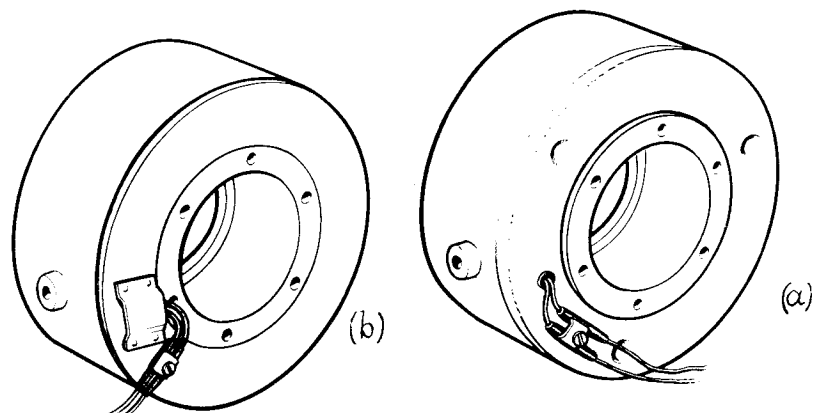

Fig. 6. Focus coil, with and without cover plate

RESTRICTED

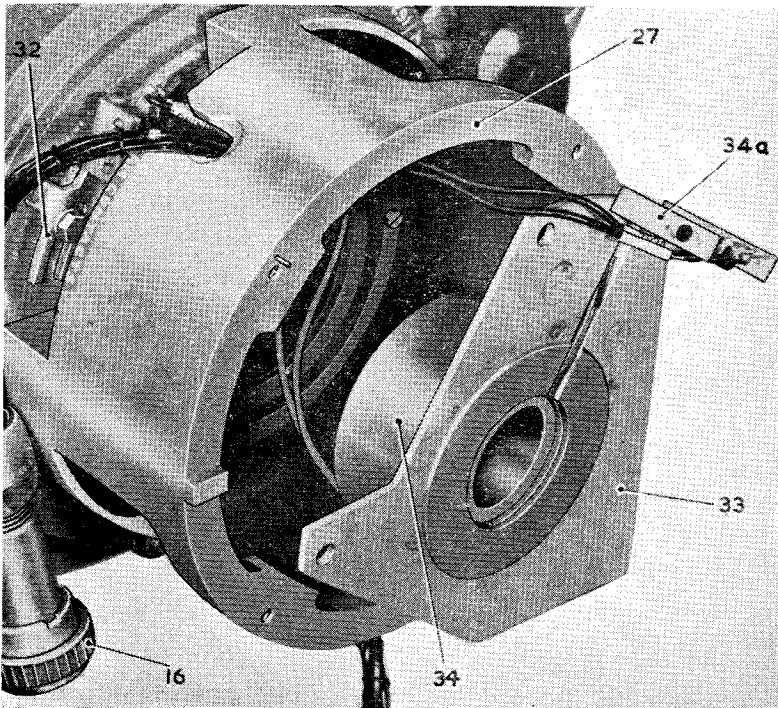

Fig. 7. Removal of centring coil

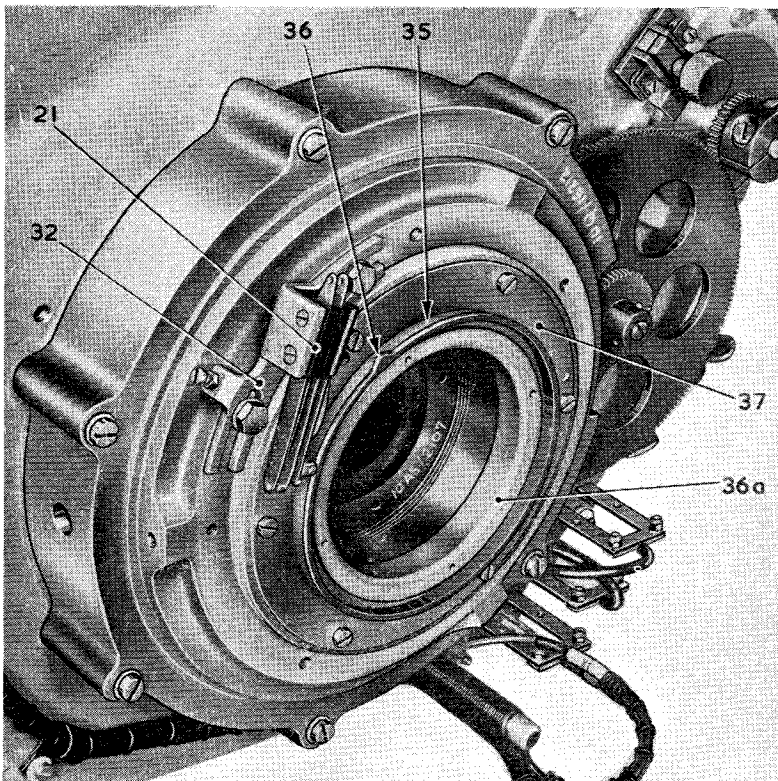

Fig. 8. Deflection coil housing exposed

as shown in fig. 8. Here (35) is the auto-align cam ring, locked in position by a flanged ring (36a). The cam itself is shown at (36), the auto-align contacts at (21), and the bracket carrying the contact assembly at (32). Note that the bracket is adjustable round a small arc by slacking off the hexagon-head bolts and sliding the bracket around, also that the roller on the innermost contact can be adjusted for pressure on the cam ring by a small set-screw with locknut.

**27.** The cam ring is anodized in a coloured finish ; it is removed from the sub-assembly by unscrewing the locking ring using a special pin spanner. On close examination of the locking ring it will be seen that there is a small collar immediately below the flange, upon which the cam ring seats. When replacing the cam, it is most important to ensure that the ring is properly seated upon this collar, otherwise the ring will be canted and the cam will not run truly. A dowel is fitted on the cam ring to ensure correct orientation.

**28.** The deflection coil housing assembly (28) can be removed as a complete unit by taking out six screws round the outside. To remove the upper bearings the auto-align contacts and auto-align cam should first be removed, and then the upper bearing is accessible by removing the retaining ring (37) (fig. 8). The lower bearing is mounted in a separate sub-assembly (bottom bearing, Stores Ref. 10AR/2140) as shown later. The position of the bottom bearing (38) with reference to the casting is seen in fig. 9. It will be seen that an annular lip on the lower screening can protrudes through the circular orifice in the casting so that the top of the lip is on approximately the same level as the top of the deflection coil, so that the screening of the latter is very nearly complete.

**29.** The illustration also shows the intermediate gears, and (through the holes in the large wheel) the top plate of the gear housing ; the latter is a complete assembly (gear assembly, intermediate, Type 132, Stores Ref. 10AR/2124). It is not mounted directly upon the casting, but

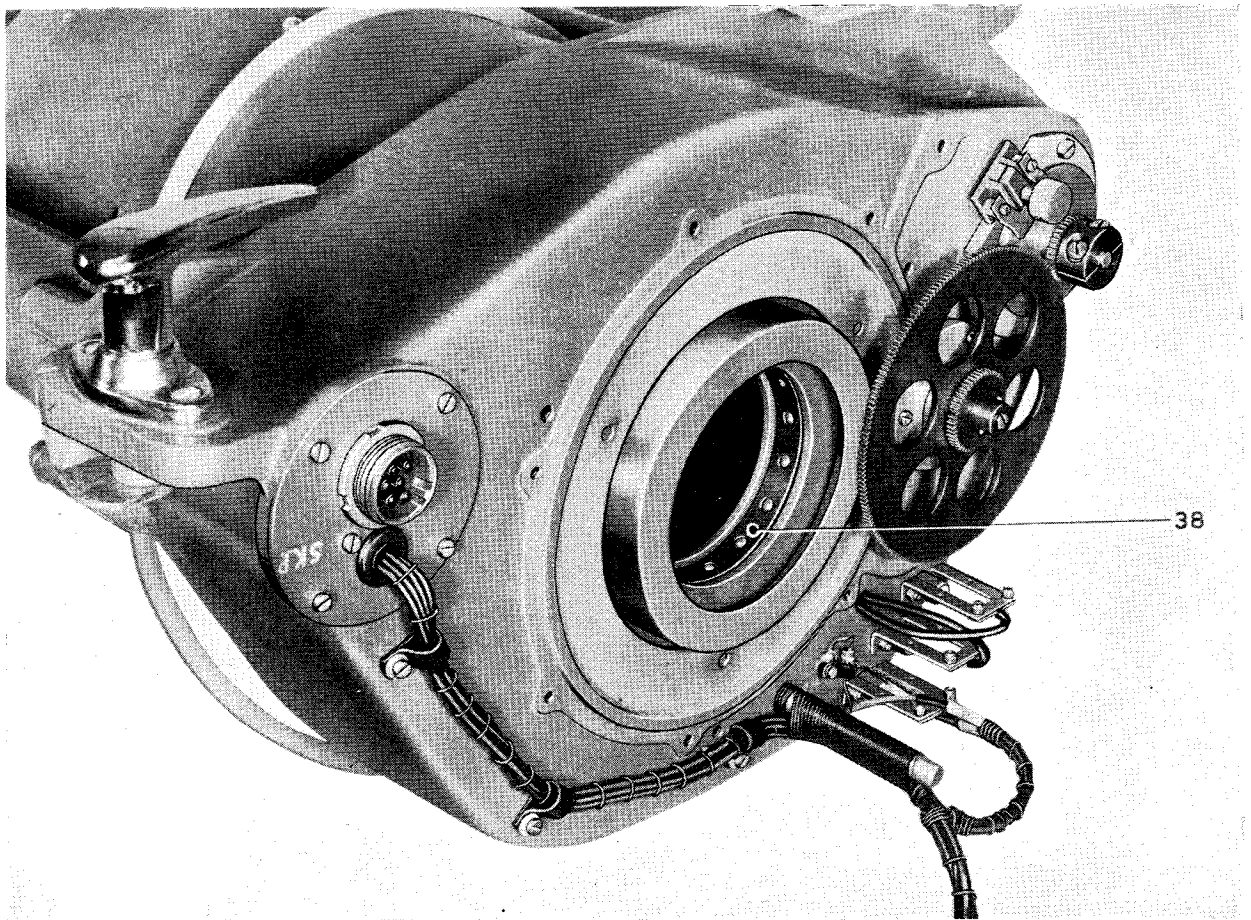

Fig. 9. Top casting after removal of deflection coil housing

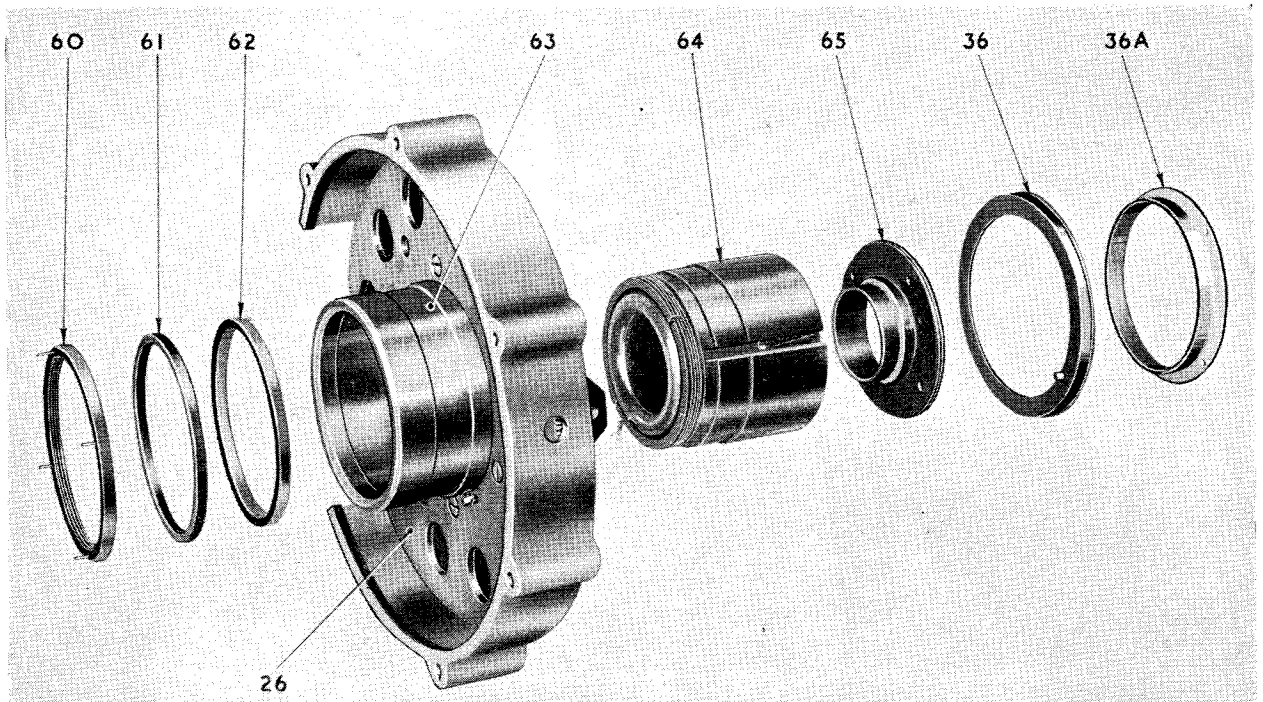

Fig. 10. Deflection coil housing and coil assembly

**RESTRICTED**

upon a mounting ring which is dowelled to the latter ; this procedure is adopted to facilitate the manufacture of interchangeable sub-assemblies.

**30.** Fig. 9 also shows how the cable form to X1 and SK.5 is secured to the top of the casting and finished by binding with p.v.c. cord to a metal post ; the extension of the cableform not shown in this illustration goes to the valve cap VI.

**31.** The manner in which the deflection coil (64) is fitted in the deflection coil mounting (63) (which is part of the deflection coil mounting assembly (28)) is shown in fig. 10. The two ends of the coil windings are soldered to small pins on the slip-rings (60) and (62) ; there are two pins on the latter, but only one is used for actual connection, and there are four pins on the former, of which only one is used. To remove the coil from its mounting, the two leads are first unsoldered from the pins with a very small iron, and the bottom ring (60) can then be unscrewed. The insulating ring (61) between the slip-rings then slides off the coil former, followed by the top ring (62). The coil (64) is finally removed by unscrewing the locking ring (65) using a suitable pin spanner, allowing the coil to be lifted out from the upper side of the housing as shown in the illustration.

**32.** The whole of the assemblies and sub-assemblies so far dealt with are shown in fig. 11, in their correct sequence. This illustration also shows the bottom bearing assembly (43) Stores Ref. 10AR/2140. This item is secured to the under side of the casting by three studs which also support the CRT locating ring. Each locating ring stud is fitted with a spring by which the ring is pressed down until held against a washer at the lower end of the stud. When the tube is correctly located, the spring is under compression owing to the upward pressure exerted by the CRT window in its mounting ring (*para.* 37-38).

**33.** The bottom bearing is held in the bearing plate by a retaining plate similar to that used on the top bearing. The deflection coil brush assembly (44) is mounted upon the bearing plate. The upper contact is wired to SK.3 and the lower one to SK.4, the leads being of Telcon, K16M cable.

**34.** The top of the screening can is between the under side of the casting and the bottom bearing plate, the studs referred to passing through clearance holes in the can ; thus the can is not held in position by these studs, but by three other studs, each of which is fitted with two pairs of washers. Each pair consists of one member which is convex on one side, and the other member of the pair has one side concave. The opposite sides of the two washers are flat. One of these washers is used on each side of the screening can where it is supported by the stud, the concave and convex sides being placed face to face in all cases.

**35.** The holes which take the screening can supporting bolts are visible in fig. 9, one being near the bottom of the casting, adjacent to the clip holding the cableform where it reaches the binding post. The other two are actually 120 deg. from this one. The ends of the three studs which hold the CRT locating ring are also seen in this illustration, one being in line with the screening can stud first mentioned.

**36.** Two views looking upward into the lower screening can are given in fig. 12. On the right, the perspex window (55) is in position. This window is flat on both sides, and is about  $\frac{1}{8}$  in. thick, but the thickness is reduced to approximately  $\frac{1}{16}$  in. over an annulus about  $\frac{1}{16}$  in. wide on the outer circumference. The side having the raised centre portion is the one which should be upwards, i.e. against the tube face.

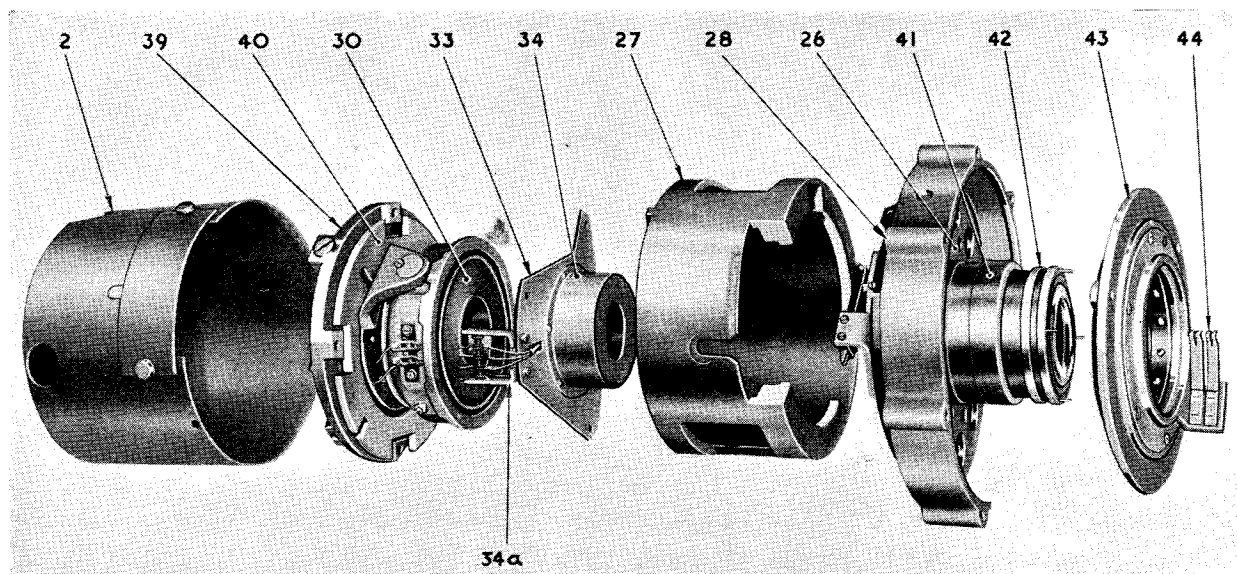

Fig. 11. Focus, centring, and deflection coil assemblies exploded view

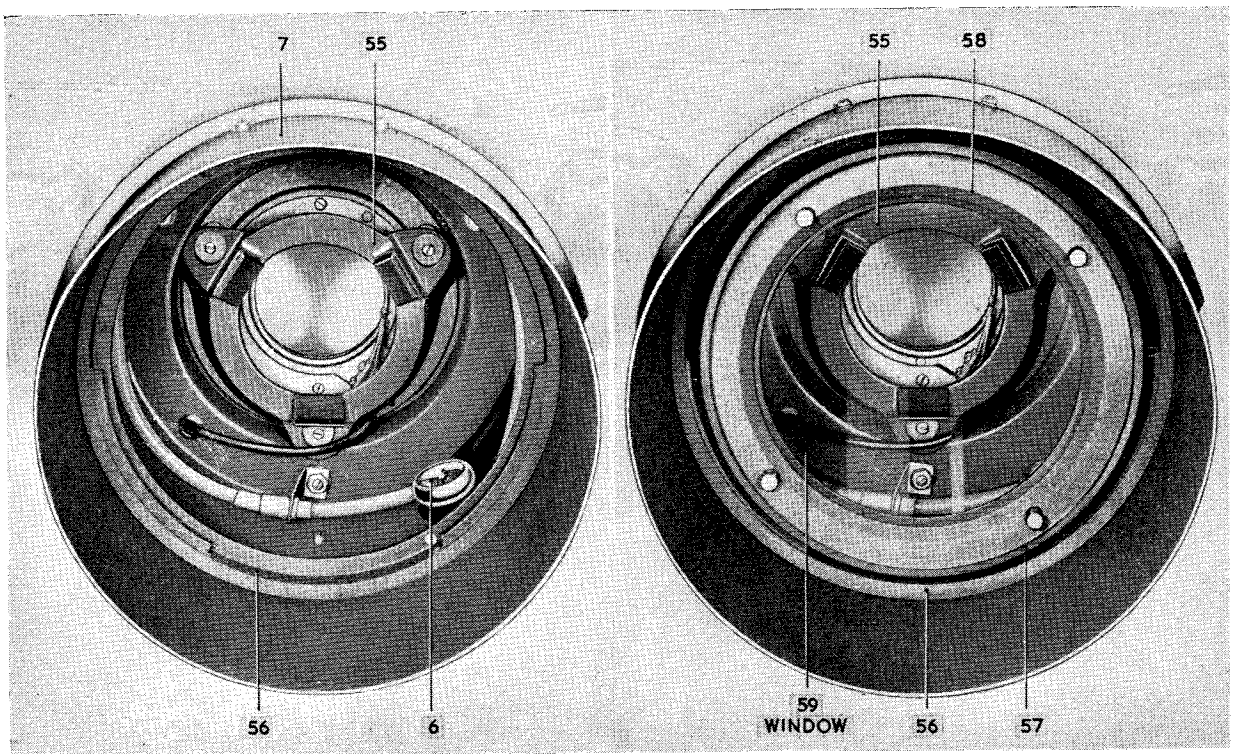

Fig. 12. Main screening can showing CRT seating and locking rings

37. The window is supported upon an inner ring (58) which is threaded round the edge, and screws into an outer ring (57), the four studs seen projecting from the latter being used to turn the inner ring. The inner ring has three sector-shaped projections which together with complementary portions on the support ring (56) form a bayonet-type joint by which the outer ring (57) is locked to the support ring (56).

38. The support ring is secured to the lower screening can by round-headed screws with washers. The inner ring, when in the operating position, is

secured there by a knurled nut with knurled lock nut, thus holding the CRT in position with the springs on the locating ring studs compressed. The CRT is removed by first slackening off the top clamp and removing the valve cap. The EHT connector must also be disconnected. The knurled locking and holding nut are then eased off, so that the outer ring can be turned through the angle (approximately 60 deg.) necessary to free it from the support ring (57). The springs will tend to force the tube downwards, and the latter must be held firmly upon the window with the fingers round the ring, holding the tube by the finger tips, until it can be firmly

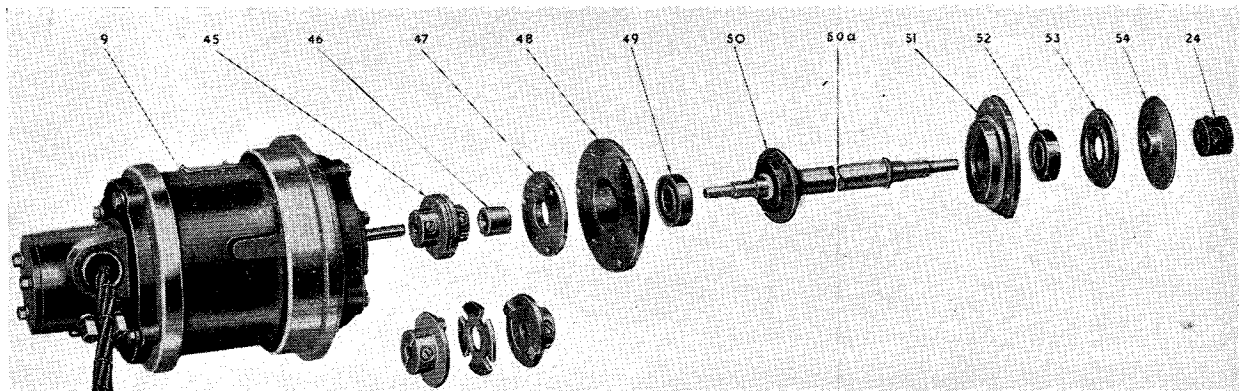

Fig. 13. Selsyn, selsyn shaft, and bearings

RESTRICTED

grasped and the stem lowered through the deflection coil and lower screen. Complete information on changing the CRT is given in Part 1, Chap. 2, of this Volume.

39. This illustration also shows the cable connecting the auto-align contacts to the sockets SK.3, SK.4 and the EHT connector.

40. Fig. 13 is a composite view of the parts comprising the selsyn (S1406B6 Stores Ref. 10P/2957), the selsyn drive shaft, and the various members of the drive up to and including the first gear wheel. The Oldham coupling is shown at (45), and the construction of the coupling can be seen from the dismantled spare one shown immediately below. The selsyn bottom bearing housing (48) holds the bottom ball bearing (49) which is retained by the plate (47). The collar (46) acts as a spacer and is pinned to the end fitting (50) of the shaft drive which passes through the bearing into the Oldham coupling.

41. The shaft proper (50a) is of light gauge duralium tube, in order to keep the inertia as low as possible. However, this means that it is somewhat fragile; and if it is removed from the indicating unit, great care must be taken in handling, otherwise there is a possibility of buckling it.

42. The upper end of the shaft runs in the bearing (52) which is carried in the housing plate (51) and retained by the cover plate (53). The clamp disc (54) is pinned to the top end of the shaft taking the place of the collar at the lower end. The first gear wheel (24) then follows, being attached to the shaft by a split collar, similarly to the Oldham coupling at the selsyn shaft.

43. Fig. 14 shows the main cableform, with its attachments to the two Jones plugs the various control potentiometers, and the main tag board; the latter is mounted inside the lower casting and is accessible after removal of a light cover plate. The six wires of the branch extending to the left are the connections to the valve V2, and those extending to the right are for the auto-align relay (fig. 2). The first branch along the main leg of the cableform is connected to SK.P, the next one to SK.5 and X1, and the final one to the valve cap V1. The small cableform connected to PLP is also shown, the leads from this plug run to TB2, TB3 and the auto-align contacts. In conjunction with the wiring diagram of the cableform (fig. 17) sufficient information is provided on this drawing for making any future modifications or repairs which may be necessary.

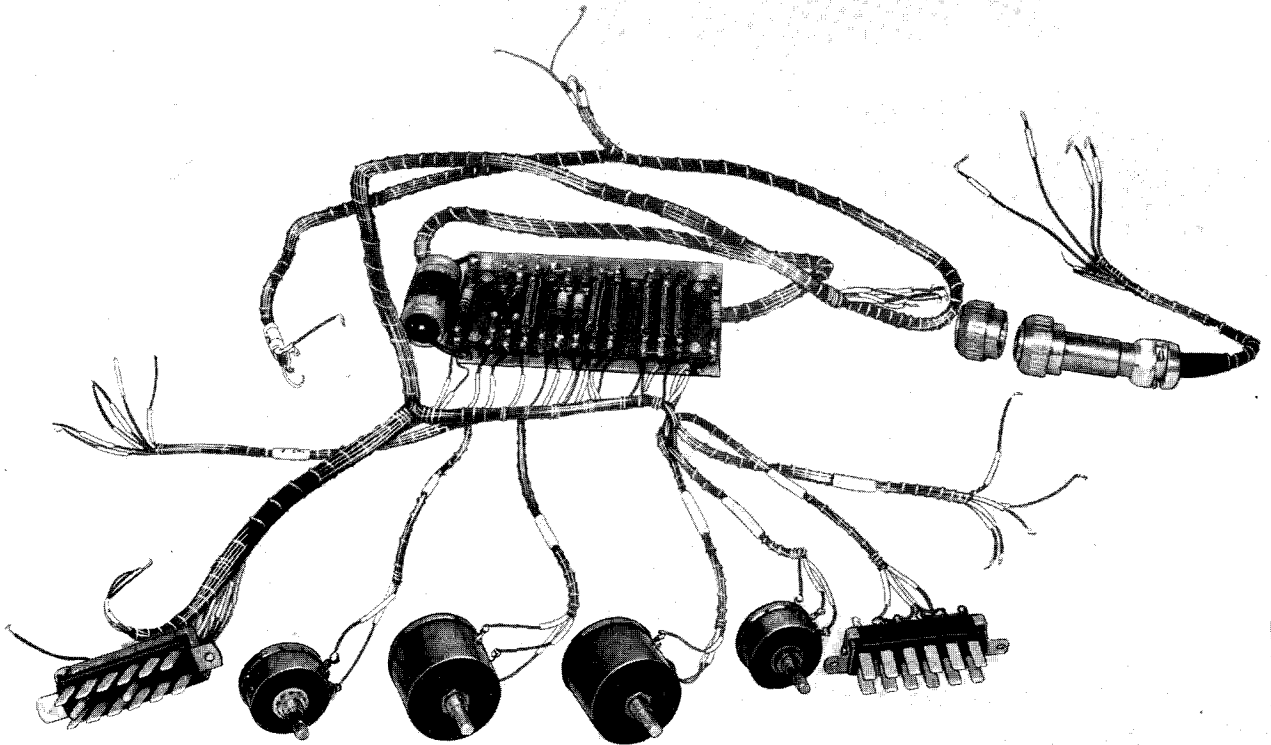

Fig.14 Tag board and cableform prior to fitting

CIRCUIT DESCRIPTION

44. The circuit diagram of the indicating unit Type 33 is given on fig. 15. The supplies for the CRT are brought in on PL.B, including the centring coil supply and that for the focus control valve V2. The selsyn circuits are brought in from the terminal block on the cabinet, connection to the auto-align relay contacts being made through PL.A.

45. The deflection coil system is rotated about the neck of the CRT through the gearing previously described, and the timebase input must therefore be applied through the slip-rings forming part of the coil assembly; these are connected to SK.3 and SK.4, the latter being fed from the timebase unit Type 137. The EHT supply is brought directly to the anode connection of the CRT from the power unit (EHT) Type 882; a thin layer of silicone grease is used upon the glass in the vicinity of the EHT cap in order to prevent corona discharge (*Part 1, Chap. 2 refers*).

46. The two pairs of centring coils have one coil of each pair connected to earth, the remaining two connections being made to the sliders of the potentiometers RV2 and RV3 respectively. These potentiometers are part of the two divider networks connected between the positive 300-volt and negative 300-volt lines on PL.B. Variation of the slider positions thus gives shift control to the CRT trace in both N-S and E-W directions.

47. Another divider network R2, RV1, is connected between the positive 300-volt line and earth, variation of RV1 varies the potential of the CRT cathode and hence controls the brilliance of the trace. At first sight it would appear that there is no connection between the cathode and this control, but actually this is made through the external circuit between PL.B (3) and PL.B (4); the latter are connected through PL.N (10) and PL.N (11) to the contacts of relay RL.2 in switch unit Type 504.

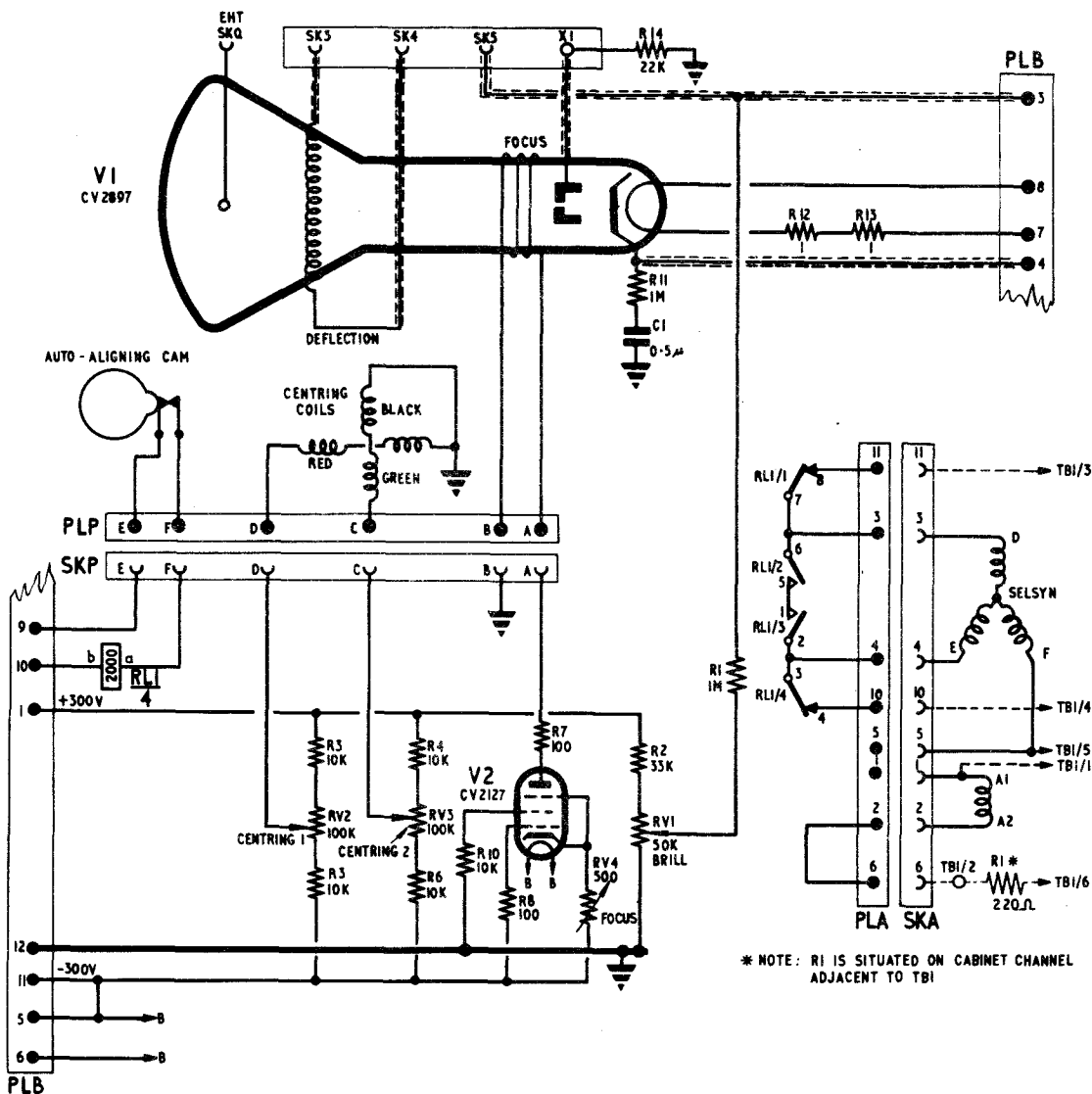

Fig.15 Indicating unit Type 33, circuit

48. The pentode V2 is used to control the current in the focusing coil, which under normal conditions is adjusted to give optimum focusing of the trace. The cathode is connected to the negative 300-volt supply, the focusing coil being connected in the anode circuit with one end earthed. Since the pentode is, when correctly adjusted, a constant-current device, any variations of supply voltage will cause negligible change in the anode current, and hence the current in the focus coil remains practically constant. Focus control is achieved by varying the current taken by the pentode, using the focus control potentiometer RV4. Note that one heater pin is connected to -300V, to prevent excessive heater-cathode potential.

**Auto-align circuit**

49. The auto-alignment circuits will be explained with reference to the simplified diagram, fig. 16. As already stated, the deflector coil drive is provided by a receiver selsyn M1, fig. 16, which is driven by a transmitter selsyn M2, mounted upon the rotating aerial system, so that the two rotate in synchronism. The direction of the timebase trace does not necessarily agree with the bearing upon which the aerial system is directed at any instant, however, because the two selsyns will lock in any one of the thirty positions of correspondence. The auto-align system ensures that the correct correspondence position is obtained, so that the

direction of the timebase trace agrees with the aerial azimuth. If for any reason (e.g., temporary failure of the AC supply to one of the selsyn rotors) the alignment is disturbed, it will be restored during the time taken by the next revolution of the aerial.

50. The cam shown on the left of fig. 16 is driven with a one-to-one ratio from the rotating aerial. The cam is circular in contour except for a projection at one point; this projection causes a pair of contacts to close momentarily once per revolution of the aerial. A similar cam (shown on the right of the diagram) is mounted in the rotating mechanism of the indicating unit, and rotates in one-to-one relationship with the deflection coils. So long as the aerial and timebase trace are in alignment, the contacts on the two cams open and close simultaneously.

51. The contacts of the cam in the aerial system are connected in series with the coil of relay A (fig. 16), on a 50-volt DC supply. Contact A1 of this relay is in series with the cam contact on the indicating unit, connected across PL.P(E) and PL.P(F) (fig. 15); this circuit includes the coil of a second relay B and a 50-volt DC supply. Relay B is fitted with two pairs of change-over contacts, B1 and B2, arranged in such a manner that when the relay operates, two phases of the receiving selsyn M1 are disconnected from their lines and short-circuited upon themselves.

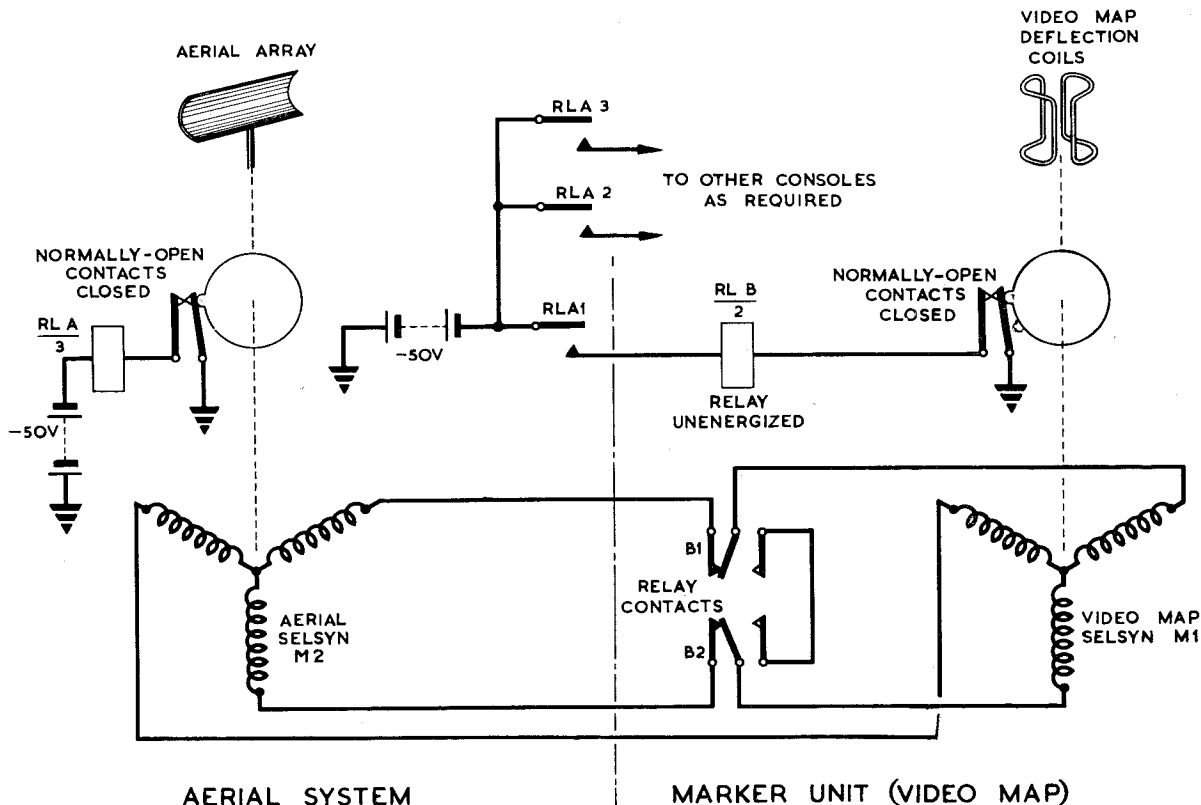

Fig. 16. Auto-align system, simplified

52. So long as the selsyns remain in alignment, the circuit to relay B is never completed because the relay A opens its normally-closed contacts when the cam contacts close. Suppose however that there occurs a short duration failure of the AC supply to the rotor of the receiving selsyn M1. This selsyn will stop, but will start to rotate again when the supply is restored, but it will not be in alignment with the aerial selsyn. The rotation of M1 will however continue only until the indicating unit cam contacts close ; at this instant the aerial cam is not in alignment with the indicating unit cam and therefore relay A is not energized. Consequently, contact A is closed and relay B is energized. The contacts of the latter disconnect two phases of M1 from the lines and short-circuit the selsyn phases upon themselves, so that the rotor of the indicating unit selsyn is rigidly locked in a stationary position with the cam contacts still closed.

53. This condition persists until the aerial reaches the position in which the aerial cam contacts close, at which instant the two selsyns are in alignment. Relay A contacts then open, releasing relay B. The receiver selsyn windings are then reconnected to their correct lines by the contacts B1, B2, and the two selsyns will then continue to rotate in synchronism with the alignment restored.

#### Cableforms

54. Fig. 17 shows the main cableform diagrammatically, and also shows the position of the various resistors on the tag board which is mounted inside the lower casting (18), fig. 1. The small cableform connecting PL.P to various terminal blocks is also included. The main point-to-point wiring is given in Table 1, that for PL.P in Table 2, and miscellaneous connections in Table 3.

TABLE 1

Main cable form

Wire type	From	To	Remarks
14/-0076	PL.B.1	TB.1.4	+300V
14/-0076	PL.B.3	TB.1.1	Brilliance
14/-0076	PL.B.4	TB.1.27	Cathode time constant
14/-0076	PL.B.5	V2.4	} Heater
14/-0076	PL.B.6	V2.5	
14/-0076	PL.B.9	SK.P.E	Auto-align contact
14/-0076	PL.B.10	RL.1.b	Auto-align relay
14/-0076	PL.B.11	TB.1.12	—300V focus control
TELCON K.16M	PL.B.3	SK.5	Brightening pulse
TELCON K.16M	PL.B.4	V1.8	Cathode switching
40/-0076	PL.B.7	TB.1.23	Heater resistor CRT
40/-0076	PL.B.8	V1.7	Heater CRT
40/-0076	TB.1.25	V1.2	Heater CRT
14/-0076	TB.1.21	V2.8	R10 to G2
14/-0076	TB.1.18	RV4.2	Focus potentiometer
14/-0076	TB.1.17	V2.2	R8 to G1
14/-0076	TB.1.15	V2.7	R7 to anode
14/-0076	TB.1.16	SK.P.A	Focus coil
14/-0076	TB.1.8	RV3.1	Centring
14/-0076	SK.P.C	RV3.2	Centring
14/-0076	TB.1.6	RV2.1	Centring
14/-0076	TB.1.2	RV1.2	Brilliance control
14/-0076	TB.1.3	RV1.3	Brilliance control
40/-0076	PL.A.4	RL.1.3	Auto-align
40/-0076	PL.A.3	RL.1.7	Auto-align
40/-0076	PL.A.10	RL.1.4	Auto-align
40/-0076	PL.A.11	RL.1.8	Auto-align
14/-0076	RL.1.a	SK.P.F	Auto-align relay coil
14/-0076	RV.2.2	SK.P.D	Centring coil
14/-0076	RV.2.3	TB.1.11	Centring
14/-0076	RV.3.3	TB.1.13	Centring
14/-0076	RV.4.1	V2.3	Focus
14/-0076	E.1	E.2	Earthing
TELCON K.16M	X.1	V1.5	Grid test point (CRT)
14/-0076	E.1	RV.1.1	Earthing
14/-0076	E.1	TB.1.E	Earthing

**TABLE 2**  
**PL.P cableform**

Wire Type	From	To	Remarks
14/·0076	PL.P.E	{ Auto-align Contacts	Direct connection
"	PL.P.F		
40/·0076	PL.P.A	TB.2.1	} Focus coil
"	PL.P.B	TB.2.2	
"	PL.B.C	TB.3.4	
"	PL.P.D	TB.3.6	

**TABLE 3**  
**Miscellaneous connections**

Connection	From	To	Remarks
	TB.3.5	Centring coil green	
	TB.3.3	Centring coil red	
	TB.3.1	Centring coil black	Earth
14/·0076	TB.3.2	E.4	Earth
40/·0076	RL.1.2	RL.1.3	
"	RL.1.6	RL.1.7	
"	RL.1.1	RL.1.5	
14/·0076	V2.3	V2.9	
"	PL.B.12	E.1	Earthing
"	PL.B.5	PL.B.11	Heater to -300V
"	PL.A.2	PL.A.6	Selsyn rotor A2
"	X.1	R.14	Test point
"	R.14	E.3	Earthing
TELCON K 16M	SK.3	Upper slip ring contact	} Direct connections
"	SK.4	Lower slip ring contact	
SELSYN TAIL	Selsyn A.1	SK.A.1	} Selsyn tails
"	Selsyn A.2	SK.A.2	
"	Selsyn D	SK.A.3	
"	Selsyn E	SK.A.4	
"	Selsyn F	SK.A.5	
40/·0076	SK.A.1	T.1	(Marked " 1 " at free end)
"	SK.A.11	T.3	(Marked " 3 " at free end)
"	SK.A.1	T.2	(Marked " 2 " at free end)
"	SK.A.10	T.4	(Marked " 4 " at free end)
"	SK.A.5	T.5	(Marked " 5 " at free end)
"	E.2	SK.P.B	Earthing
"	Anode V1	SK.Q	EHT supply
	TB.2.1	Focus coil red	} Direct connections
	TB.2.2	Focus coil black	

## KEY TO FIG. 1

- 17 LOCKING HANDLES
- 18 PANEL WITH FOCUS, BRIGHTNESS, AND CENTRING CONTROLS

## KEY TO FIG. 2

- 1 VALVE CAP (VI)
- 2 TOP SCREENING CAN
- 3 UPPER CASTING
- 4 SPRING LOADED CATCH
- 5 LEFT-HAND SUPPORT TUBE
- 6 EHT CAP
- 7 MAIN SCREENING CAN
- 8 AUTO-ALIGN RELAY
- 9 SELSYN
- 10 JONES PLUG A
- 11 OPTICAL FOCUS SCREW FOR LENS UNIT
- 12 JONES PLUG B
- 13 VALVE V2
- 14 LOWER CASTING
- 15 RIGHT-HAND SUPPORT TUBE
- 16 PL.P and SK.P
- 22 COAXIAL SOCKETS AND TEST POINT

## KEY TO FIG. 3

- 16 PL.P
- 19 GEARING ACCESS COVER
- 20 CRT STEM CLAMP HOLDER
- 20a SCREWS KNURLED 10AC/968
- 21 AUTO-ALIGN CONTACTS AND COVER PLATE
- ◀21a CLAMP PAD ▶

## KEY TO FIG. 4

- 23 GEARING CLAMP
- 24 FIRST GEAR WHEEL WITH CLAMPING DISC
- 25a LARGE WHEEL OF INTERMEDIATE GEAR
- 25b SMALL WHEEL OF DITTO
- 26 FINAL GEAR WHEEL
- 27 TOP BODY RING
- 28 DEFLECTION COIL HOUSING
- 39 TOP PLATE WITH FOCUSING SCREWS

## KEY TO FIG. 5

- 27 TOP BODY RING
- 28 DEFLECTION COIL HOUSING
- 29 OUTER GIMBAL OF FOCUS COIL MOUNTING
- 30 FOCUS COIL
- 31 FOCUS COIL TAG BLOCK TB2
- 32 AUTO-ALIGN CONTACT BRACKET
- 39 TOP PLATE WITH FOCUSING SCREWS

## KEY TO FIG. 7

- 16 SK.P
- 27 TOP BODY RING
- 33 CENTRING COIL PLATE
- 34 CENTRING COIL
- 34a CENTRING COIL TAG BLOCK TB3

## KEY TO FIG. 8

- 21 AUTO-ALIGN CONTACTS
- 32 AUTO-ALIGN BRACKET
- 35 AUTO-ALIGN CAM RING
- 36 AUTO-ALIGN CAM
- 36a LOCKING RING FOR ABOVE
- 37 UPPER BEARING RETAINING RING

## KEY TO FIG. 9

- 38 DEFLECTION COIL BEARING (LOWER)

## KEY TO FIG. 10

- 26 FINAL GEAR WHEEL
- 36 AUTO-ALIGN CAM
- 36a LOCKING RING FOR ABOVE
- 60 SLIP RING OUTER
- 61 SPACER TYPE 310 10B/17272
- 62 INNER SLIP RING
- 63 DEFLECTION COIL MOUNTING
- 64 COIL DEFLECTING TYPE 100 10Q/16216
- 65 RETAINER DEFLECTING COIL 10AS/2017

## KEY TO FIG. 11

- 2 TOP SCREENING CAN
- 26 FINAL GEAR WHEEL
- 27 TOP BODY RING
- 28 DEFLECTION COIL HOUSING
- 30 FOCUS COIL
- 33 CENTRING COIL PLATE
- 34 CENTRING COIL
- 34a CENTRING COIL TAG BLOCK TB3
- 39 TOP PLATE
- 40 FOCUS COIL MOUNTING PLATE
- 41 DEFLECTION COIL MOUNTING WITH COIL FITTED
- 42 DEFLECTION COIL WITH SLIP RINGS AND SPACER FITTED
- 43 DEFLECTION COIL BOTTOM BEARING PLATE
- 44 DEFLECTION COIL CONTACT ASSEMBLY

## KEY TO FIG. 12

- 6 EHT CAP
- 7 MAIN SCREENING CAN
- 55 CRT SEATING RING
- 56 FIXED RING OF BAYONET JOINT
- 57 INNER RING OF BAYONET JOINT
- 58 CRT LOCKING RING
- 59 WINDOW, PERSPEX

## KEY TO FIG. 13

- 9 SELSYN
- 24 FIRST GEAR WHEEL
- 45 COUPLING TYPE 323 10AC/967
- 46 SPACING COLLAR
- 47 RETAINING PLATE
- 48 BEARING PLATE
- 49 LOWER BEARING OF SHAFT
- 50 SHAFT WITH BOTTOM RETAINER
- 50a DURAL SHAFT
- 51 TOP BEARING PLATE
- 52 TOP BEARING
- 53 TOP BEARING RETAINER
- 54 SHAFT CLAMPING DISC



## Chapter 3

# LENS UNIT TYPE 26 and PHOTO-ELECTRIC UNIT TYPE 100

### LIST OF CONTENTS

	Para.
Optical assembly ... ..	1
Photo-electric unit Type 100 ... ..	14

### LIST OF ILLUSTRATIONS

	Fig.		Fig.
Lens unit Type 26, front view ... ..	1	Photo-electric unit Type 100, circuit... ..	5
Lens unit, showing map position controls ... ..	2	Photo-electric unit Type 100, front view ... ..	6
Lens unit, underside ... ..	3	Photo-electric unit Type 100, rear view ... ..	7
Details of mirror assembly ... ..	4		

#### Optical assembly

1. The complete optical system, comprising two identical arrangements of lens, glass map slide, map table, map carriage, and photo-electric multiplier is contained in a light-proof cast metal box known as lens unit Type 26. The photo-electric multipliers are actually part of the photo-electric unit Type 100, which is attached to the base of the lens unit so that in effect the two units form one assembly, the general appearance of the lens unit being shown in fig. 1, and that of the photo-electric unit in fig. 6.

2. The photo-electric unit Type 100 carries the two photo-electric multipliers upon its upper face so that they project into the lens unit case. It also contains the two head amplifiers for the video responses from the photo-electric multipliers, the other valves being mounted on the front outside the case (fig. 6).

3. The entire optical assembly is supported between the vertical support tubes of the indicating unit (CRT) Type 33 by three guides, two on the left-hand side, and one on the right, as viewed from the front when in the operating position. These guides are rigidly attached to the body of the lens unit, and each is fitted with a locking bolt so that the optical assembly can be locked in the position of optimum focus after the focusing operation has been performed. In order that the two optical systems can be focussed simultaneously, the operation is performed by moving the entire optical assembly with relation to the tube face.

#### Note . . .

*This optical focusing must not be confused with the electronic focusing of the CRT; the two are not related in any way. It follows that a deterioration of CRT focus cannot be corrected by adjusting the optical focus, or vice versa.*

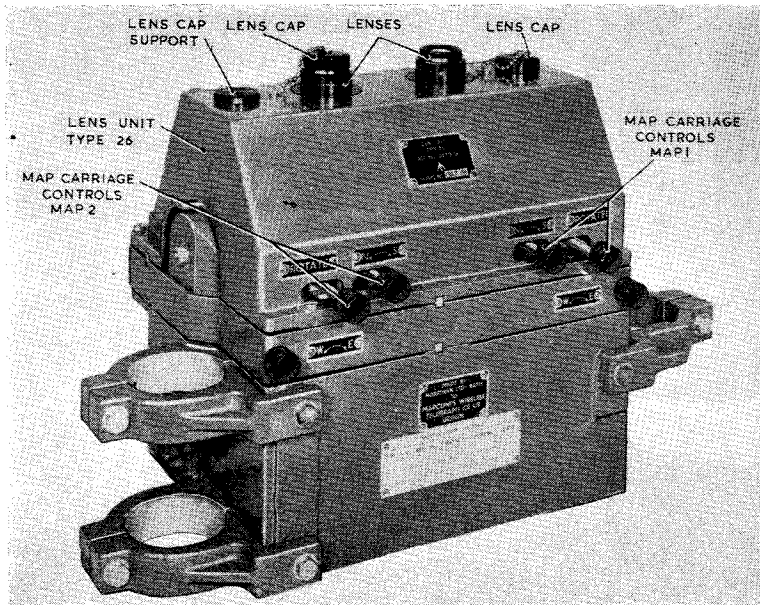

Fig. 1. Lens unit Type 26, front view

4. A threaded rod passes through the lower casting of the indicating unit, the upper end being rounded off to engage with a depression on the underside of the lens unit (*fig. 3*). When the locking bolts referred to in the preceding paragraph have been slackened off, the optical assembly may be moved upwards or downwards on the support tubes by turning the knurled knob of the threaded rod. When the correct focus is obtained, the threaded rod is locked in position by a holding nut and locking nut, after which the locking bolts should be tightened to prevent erratic performance due to vibration.

5. During its final tests at the maker's works, the optical assembly is positioned upon the support tubes in the position of optimum focus, and it should rarely be necessary to alter this position. Accordingly, this should not be undertaken unless the optical assembly has been removed from the support tubes for some reason, or unless a serious deterioration of performance throws suspicion upon the optical focus (*Note to para. 3 refers*). Full details of the manner of correcting this are given in Part 1, Chapter 2, of this Volume.

6. Referring to *fig. 1*, the two field lenses are mounted on top of the lens unit, each being sup-

ported in a special mounting. Cover caps are provided to protect the lenses during transit, and also to prevent the accumulation of dust during periods of disuse. They should always be used to cover the lenses during such periods. A captive chain and stowage position is provided for each cap.

7. The three controls for each of the map carriages are knurled knobs, marked W-E (West-East), N-S (North-South), and ROTATE respectively. The two former cause the map carriage to traverse linearly in the indicated directions, while the third causes the map table to slew about its centre so that the north of the map can be aligned with the North marker (or its equivalent) on the PPI (*Part 1, Chapter 2 of this Volume refers*).

8. The upper portion of the lens unit is secured to the lower portion by screws (the rear corner one and one of the front ones adjacent to the left-hand ROTATE control are seen in *fig. 1*). Before removing this cover it is necessary to remove the knobs of the ROTATE and N-S controls. Such removal is rarely necessary, however, since access to the map slides and map carriages is given by a hinged door forming the sloping rear side of the cover.

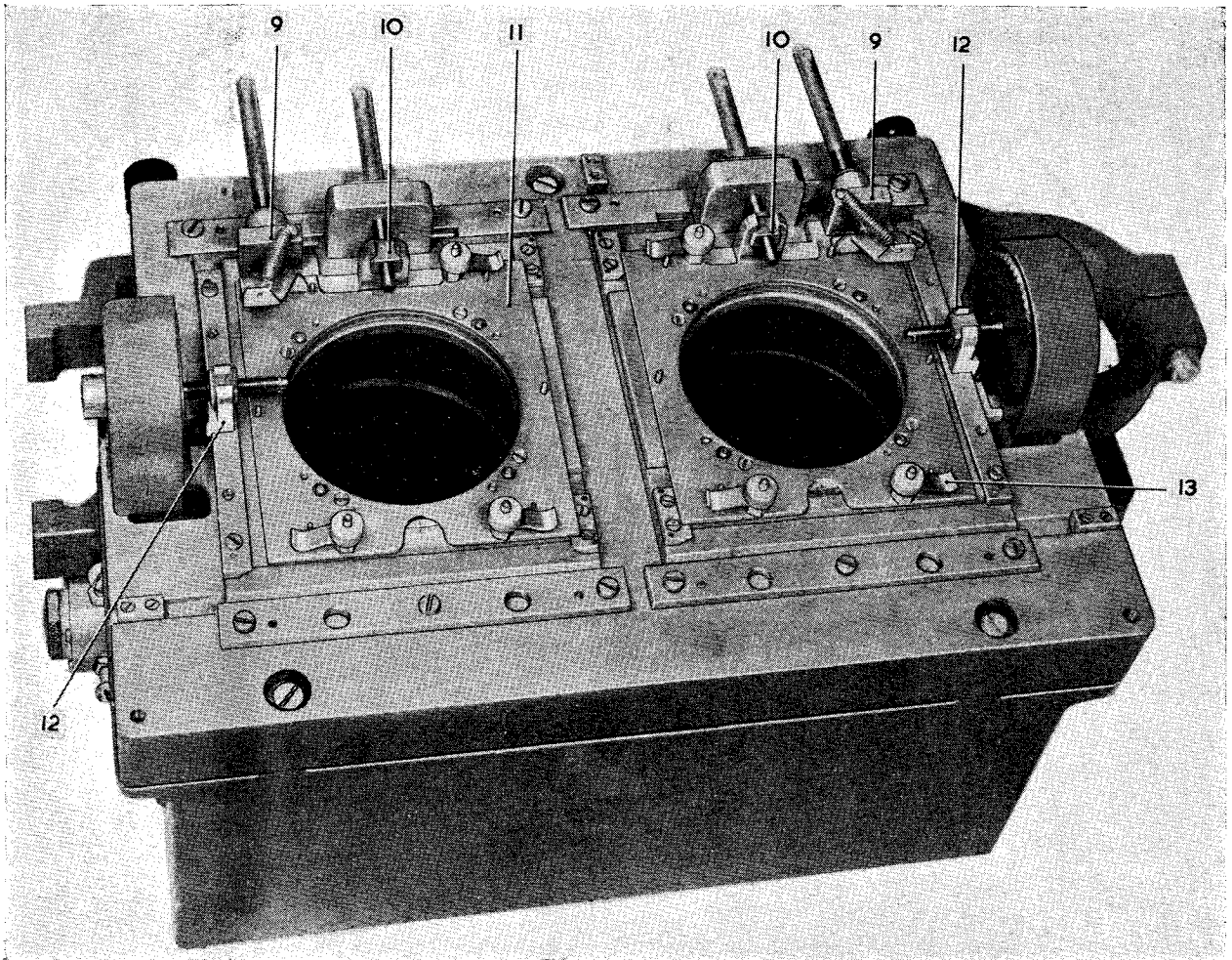

9 ROTATE ADJUSTMENT                      11 MAP SLIDE TABLE  
 10 N-S ADJUSTMENT                        12 E-W ADJUSTMENT  
 13 MAP CLIP

**Fig. 2. Lens unit, showing map position controls**

**9.** Fig. 2 shows the lens unit with the top cover removed. The manner in which the map carriage controls operate upon the map carriages can be seen in this illustration. It will be seen that the N-S control operates a threaded rod which passes through a threaded bush attached to the map carriage, so that by turning the control the carriage is moved towards or away from the reader. The E-W control however operates a worm driving a worm wheel, the latter turning a threaded rod passing through a corresponding bush on the carriage. The map slide table is fitted on the map carriage in such a manner that it can be slewed through a small angle by the ROTATE control bearing upon the small bracket at the corner of the table, against the action of a spiral spring.

**10.** The map slide (the glass slide carrying the map proper) fits upon the map slide table and is located by small pins which can be seen in the illustration. When in place, it is held by spring clips (13) which are lifted over the adjacent pins

so as to press lightly upon the glass near the edge. Below the circular orifice in each map slide table is the mounting for the condenser lens.

**11.** The top casting carrying the controls, etc., just mentioned can also be removed, being held by three screws whose heads are recessed into wells as shown. Fig. 3 is a view of the interior of the box taken from the under side, after the photo-electric unit Type 100 has been removed; the six tapped holes for the screws holding the latter are shown, round the edge of the rectangular aperture through which the top casting is seen. The condenser lenses (2) are mounted in cylindrical formers of laminated plastic material, the light passing through the map being directed upon the two mirrors (1). Each mirror is carried in a special ball and socket sleeve (3) with four adjusting screws on the outside of the lens unit, so that the mirror may be adjusted to correct relationship with reference to the condenser lens and the photo-electric multiplier.

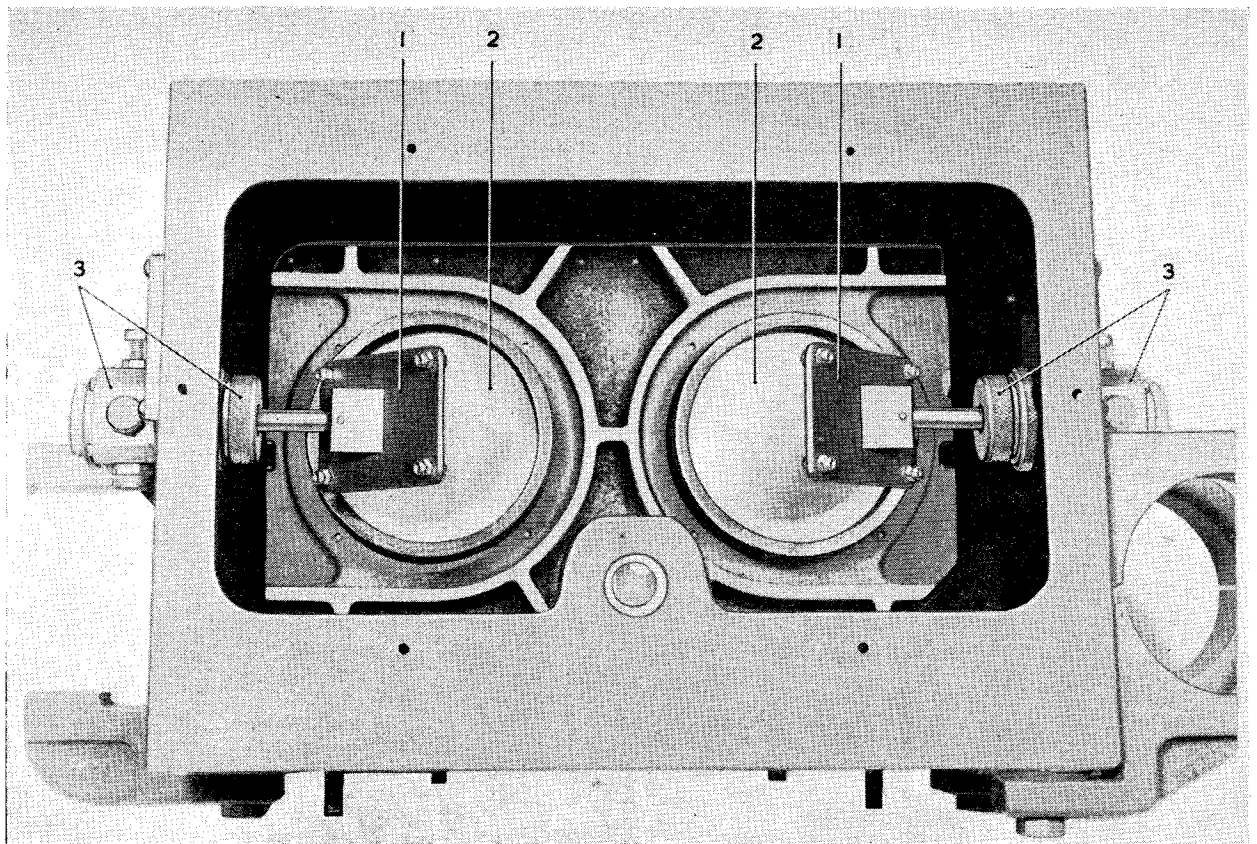

1 MIRROR      2 CONDENSER LENS      3 MIRROR ADJUSTMENT

**Fig. 3. Lens unit, underside**

**12.** Details of the mirror and mirror support are given in fig. 4. The support plate is attached to the outside of the box by screws, and the body of a socket passes through the plate, where it is held by a locking ring. The shaft carrying the mirror has a ball near its middle, and an enlarged end ground with four flat sides. The shaft is located in the socket formed between the adjusting ring (9) and the body.

**13.** Movement in any direction is controlled by two spring-loaded plungers (7) (8) held in position by caps (5), and two screws (4), the latter being fitted with locking nuts. The end cover cap (6) is clear of the end of the mirror shaft when screwed home, so that it does not impede the free movement of the shaft when being adjusted.

#### **Photo-electric unit Type 100**

**14.** As already stated, the optical system is duplicated in order to give two separate video outputs from the same assembly. It follows that the whole electronic system consisting of photo-electric multiplier, head amplifier, and video amplifier must also be duplicated. Both the head amplifiers, and the associated photo-electric multipliers, are shown in the circuit diagram of the photo-electric unit Type 100 (fig. 5).

**15.** The circuit consists of two photo-electric multipliers followed by amplifiers which are

identical, so that only one need be described. There is however a slight difference between the potential divider networks feeding the two photo-electric multipliers V1 and V5. The HT voltage ( $-1,000$  volts) for V1 is applied across a divider network R1 to R7, from which are tapped the electrode voltages for the first six dynodes, R1 being connected to earth. The arrangement for V5 is similar except that instead of being earthed, one end of the HT network R23 to R28 is taken via R29 and P.L.M to the control circuits in the 300-volt power unit. Further details of this control system will be found in Chapters 6 and 7 of this Part.

**16.** The three final dynodes, where the current drain is greatest, are supplied from the negative 300-volt power unit P.L.M(11). The potentials for these electrodes are tapped off the potential dividers R10, R11, R12 in the case of V1 and R32, R33, R34 in the case of V5, these chains being connected directly across the  $-300V$  supply.

**17.** Taking now the MAP 1 amplifier V1, V2, V3a, V4; the output from the anode of V1 is applied to the control-grid of V2 and appears in amplified form across R14, the anode load of V2. Negative current feedback is applied via the adjustable resistor RV1 (1K max.) partly to stabilize the amplifier, but also to provide a means for adjusting the gain (*para.* 20).

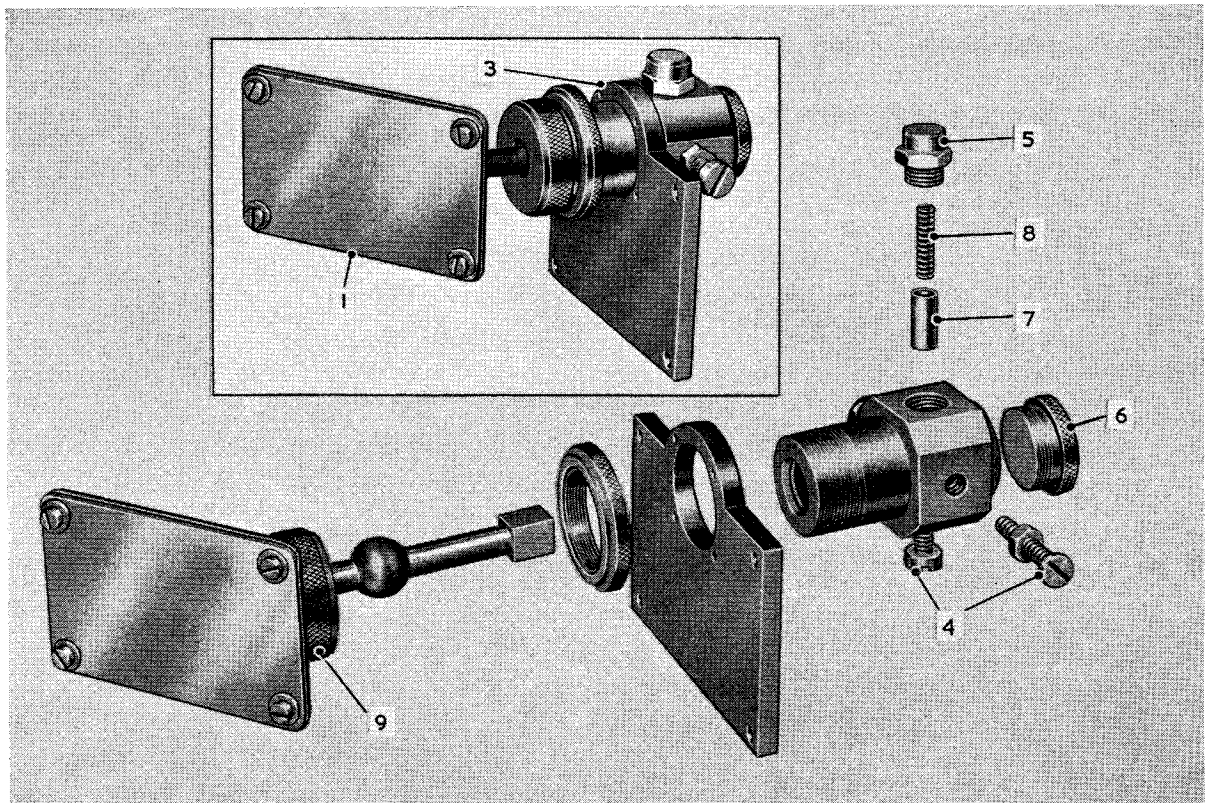

1 MIRROR                      3 MIRROR ADJUSTMENT      4 ADJ. SCREW                      5 CAP (TOP AND SIDE)  
 6 END CAP                      7 PLUNGER                      8 PLUNGER SPRING                      9 INNER ADJUSTING RING

**Fig. 4. Details of mirror assembly**

**18.** The output of V2 is applied via C1 to the control grid of the cathode follower V4, the video output being developed across R19 and R20. This output is taken via SK.1 to the amplifying unit (video) Type 298. The diode V3a provides DC restoration in the control-grid circuit of V4 to compensate for the charge and discharge time-constant of the circuits associated with C1. The pulses through C1 are positive-going, but at the end of each pulse a negative-going over-shoot occurs. To reduce this, the anode of V3a is connected to the bias tapping on the resistor chain R21, R22; the control-grid of V4 is normally held at a potential of -3 volts from this resistor chain, the cathode of the diode being connected to the top end of the grid leak resistor R17. Provided therefore that the negative overshoot at the control-grid of V4 is less than 3 volts, the anode is negative to the cathode and the diode does not affect the operation of the circuit. If the control-grid potential falls below the -3 volts, however, the diode becomes conductive and the control-grid is brought back to practically earth potential, owing to the low resistance of R21.

**19.** Test points X1, X3, etc., are provided, each being associated with a 4.7 ohm resistor. With VR1 at minimum, the current of V2 should be between 2 and 10mA. The current of V4, read at X3, should be between 2 and 5mA. The current of V1, read at X1, should be zero or slightly negative. Similar readings should of course be obtained for the MAP 2 amplifier.

**20.** The gain controls in the negative feedback chains of the two amplifiers are used primarily to equalize the gain of the two, so that no adjustments are necessary if the operator switches from one map to the other. This control is necessary to allow for variations in light sensitivity between different CV337 valves. When setting up, they should first both be set to give 8mA at the test point (or the maximum obtainable if less than this). The two outputs are then inspected upon an oscilloscope, and the greater of the two reduced to equality with the other by adjustment of the gain control, RV1 or RV2.

**RESTRICTED**

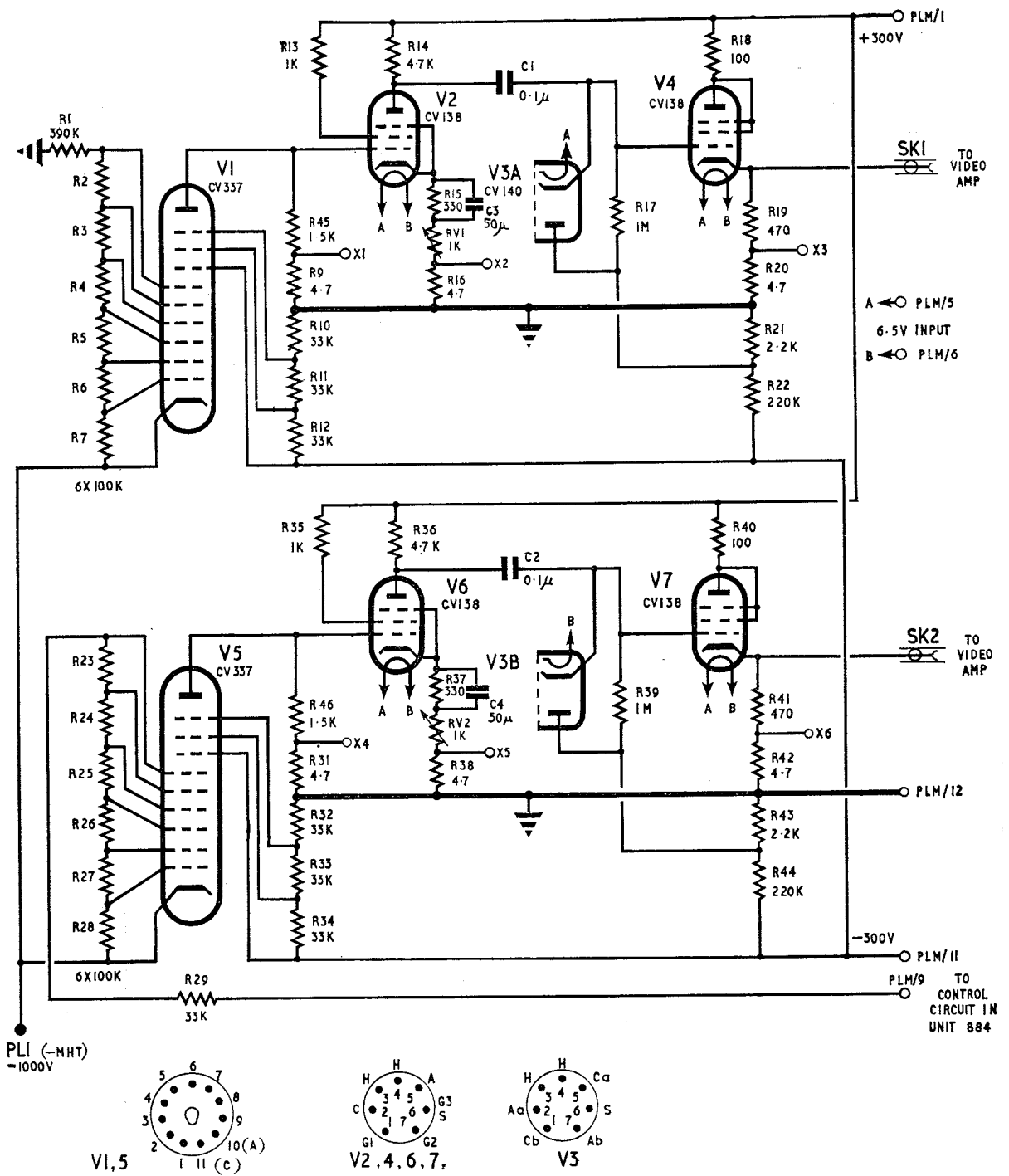

Fig. 5. Photo-electric unit Type 100, circuit

RESTRICTED

21. The general appearance of the photo-electric unit can be seen in fig. 6. The two multiplier tubes V1 and V2 (CV337) are normally mounted in the valve-holders shown on top of the unit, projecting into the lens unit. The amplifiers are arranged one at each end, with each output socket adjacent to its amplifier. The appropriate test points are grouped on each end of the box.

22. An underside view of the unit is given in fig. 7. It will be appreciated that the gain controls RV1, RV2 are accessible through holes in the underside of the dust case, when the unit is installed.

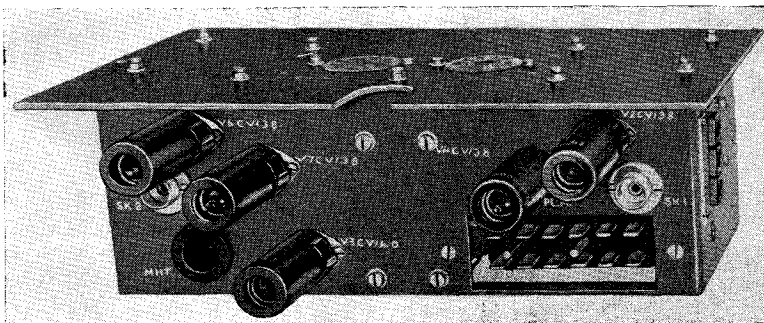

Fig. 6. Photo-electric unit Type 100, front view

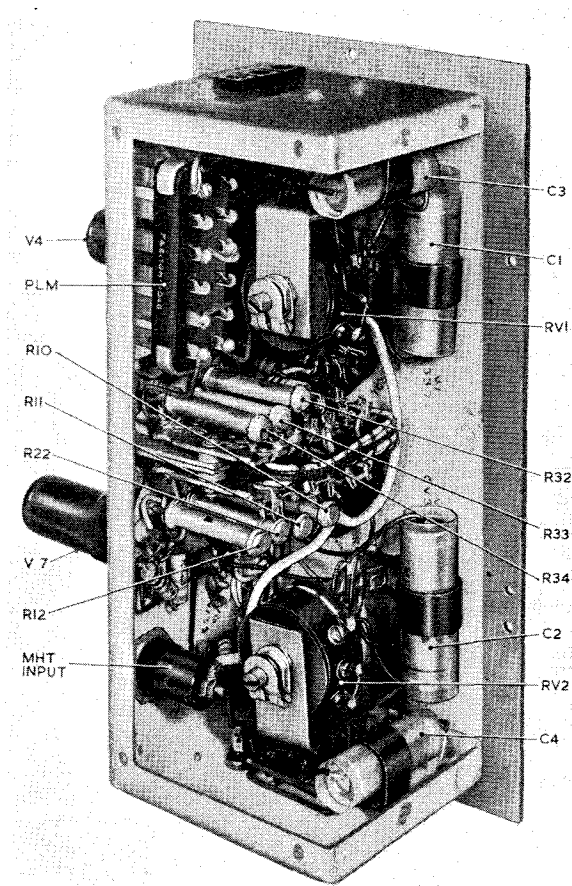

Fig. 7. Photo-electric unit Type 100, rear view

## Chapter 4

### AMPLIFYING UNIT (VIDEO) TYPE 298

#### LIST OF CONTENTS

	<i>Para.</i>
<i>Circuit description</i> ... ..	1
<i>Construction</i> ... ..	8

#### LIST OF ILLUSTRATIONS

	<i>Fig.</i>
<i>Components on rear of chassis</i> ... ..	1
<i>Amplifying unit (video) Type 298</i> ... ..	2
<i>Amplifying unit (video) Type 298, circuit</i>	3

#### ◀LIST OF APPENDICES

	<i>App.</i>
<i>Amplifier video 5840-99-946-7733</i> ...	1▶

#### Circuit description

1. The function of the video amplifying unit is to further amplify (or in some cases limit) the outputs from the two photo-multiplier head amplifiers in the scanning assembly. The complete unit is made up of two identical amplifier chains, not in any way inter-related, each being fed from one of the two outputs from the scanning assembly.

2. The circuit diagram (*fig. 3*) shows the two separate amplifiers, one consisting of the valves V2 to V8 and the other of valves V9 to V16. Since their operation is identical it will be necessary only to describe the amplifier V2 to V8.

3. The output from the scanning assembly head amplifier consists of a series of positive-going pulses; these are applied, via C1, to the control-grid of V2. The diode V1a, connected between this grid and earth, is a DC restorer to the input line. V2 itself is a buffer amplifier providing high-frequency compensation of the incoming signal by the use of a choke L1 connected in its anode circuit. The positive-going pulses applied to its control-grid appear as amplified negative-going pulses across the anode load made up of R4 and L1.

4. V3 is the limiter stage. Under quiescent conditions it operates under zero bias conditions, its anode current value being controlled by the screening-grid potentiometer RV1. When the negative-going pulse output from V2 is applied to

the grid of V3, this grid is driven negative. If any of the pulses exceed a given selected value the grid may be driven to cut-off point and beyond, and V3 anode current will cease to flow. Further increase in input above the selected value cannot produce any increase in output, and therefore positive-going limited pulses will appear across the anode load R8.

5. This output is fed via C4 to five cathode-follower stages V4 to V8, whose control-grids are connected in parallel. V11a is a DC restorer which holds the mean control-grid voltage of the cathode-follower at about  $-50$  volts. The five cathode-follower stages provide five separate output channels, the positive-going pulses being developed across the 100-ohm cathode resistor of each stage (R15, R19, R23, R28 and R32, respectively). The output from each stage is adjusted by the limiting stage to 1.5 volts.

6. Under static conditions, with no input to the cathode-followers, the grids of the five valves V4 to V8 are held at a negative potential of V11a. This negative voltage is derived from the potential divider R25, R11 connected across the  $-300$  volt supply. It has also been arranged that the anode current of V3 (under quiescent conditions) is approximately equal to the combined anode currents of V4 to V8 under working conditions, thus giving a certain amount of compensation for the varying current drawn from the HT supply.

RESTRICTED

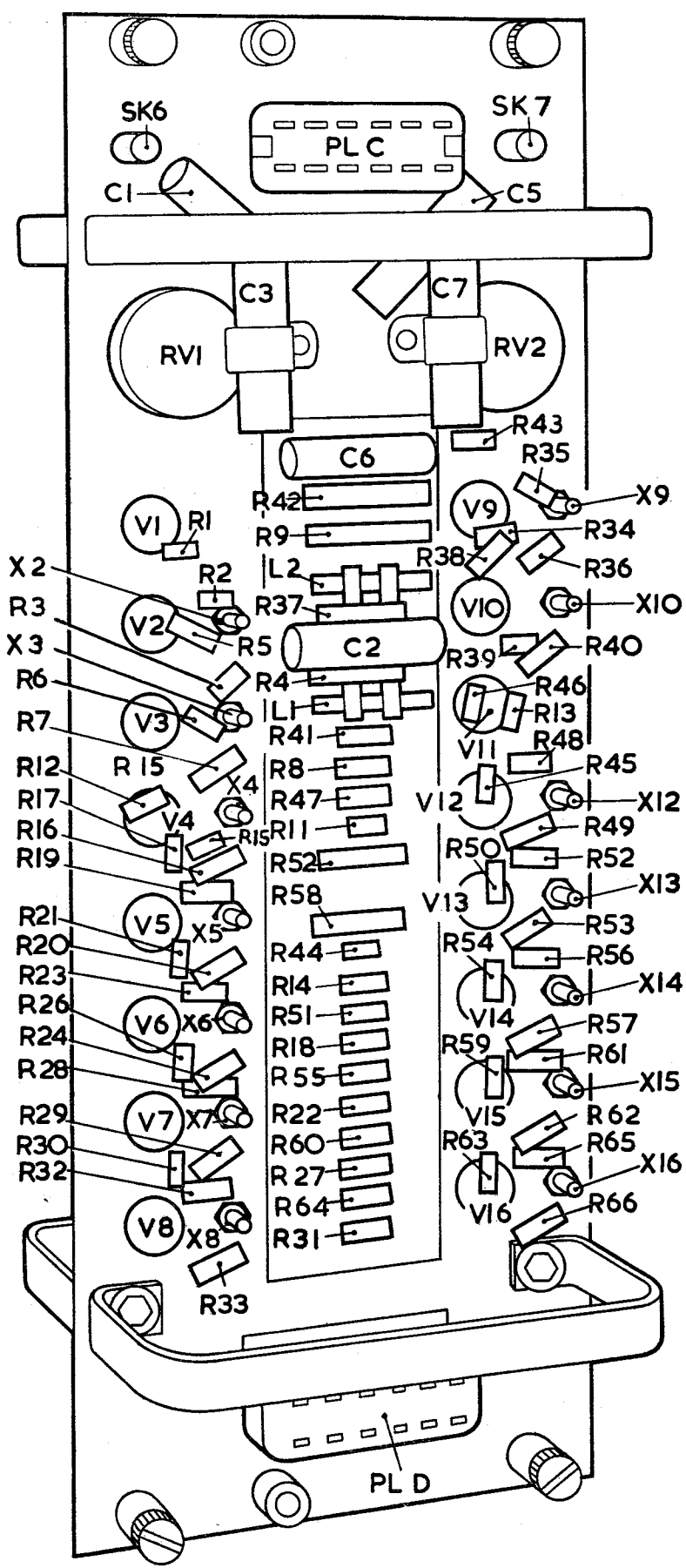

Fig. 1. Components on rear of chassis

RESTRICTED

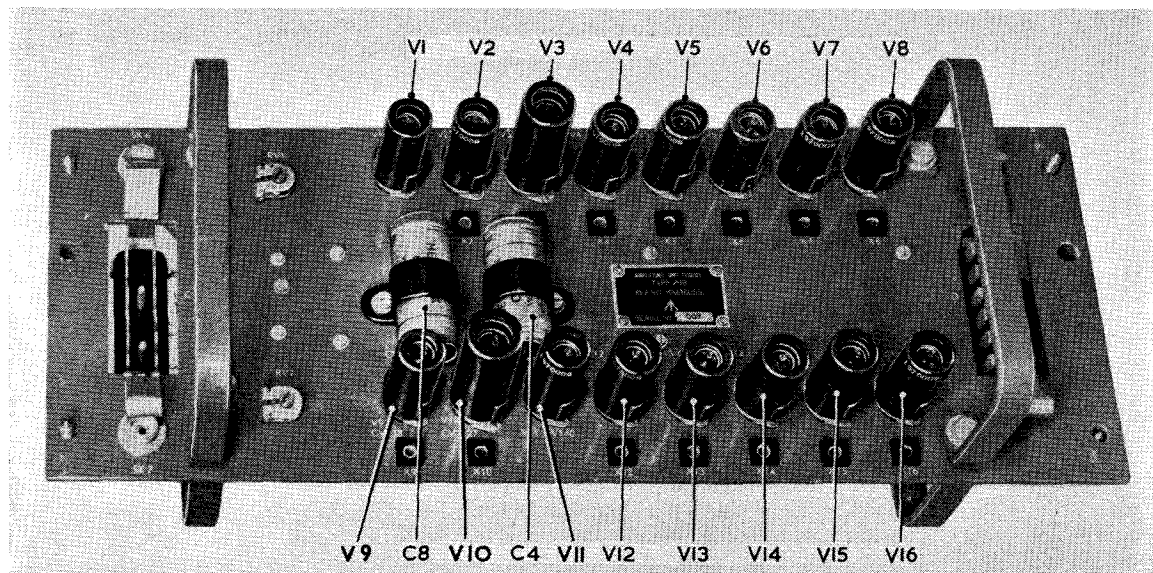

Fig. 2. Amplifying unit (video) Type 298

7. This unit also is provided with a series of test points X2 to X16 in the cathode circuits of the valves. Each test point has its associated shunt resistor of the correct value so that a single meter may be used for checking the operation of any stage. The two separate amplifier chains V1 to V8 and V9 to V16 respectively, are fed from separate heater supplies.

#### Construction

8. A front view of the amplifying unit is given in fig. 2 in which it is seen that all the valves in each amplifier chain are arranged in a row, the two chains being one above the other. The upper chain however includes the double-diode V1 which serves both chains. The two large coupling capacitors C4, C8 are also mounted on this side of the chassis. The test sockets are fitted in front of the appropriate valve.

9. Two coaxial sockets SK.6, SK.7 are provided for the video inputs to the two chains. Preset con-

trols are fitted on this side of the chassis for the gain control potentiometers RV1 and RV2.

10. The arrangement of the rear of the amplifying unit is shown in fig. 1. The majority of the small components are mounted on a group board between the two sets of valve bases. The resistors associated with each test socket, however, are mounted immediately adjacent thereto.

11. The two large capacitors C1 and C5 are the coupling capacitances from the input sockets to V2 and V9 respectively; C2 and C6 are the coupling capacitors between V2 and V3, and V9 and V10 on the respective chains. The electrolytic capacitors C3 and C7 are mounted adjacent to RV1 and RV2 respectively, and the coupling capacitors to the cathode-follower stages are mounted on the other side of the chassis as already shown.

12. The compensating chokes L1 and L2, with their series resistors R4, R37, are mounted adjacent to capacitor C2.

## Appendix 1

### AMPLIFIER VIDEO 5840-99-946-7733

#### LIST OF CONTENTS

	<i>Para.</i>
<i>Introduction</i> .. .. .	1
<i>Circuit description</i> .. .. .	3

#### LIST OF ILLUSTRATIONS

	<i>Fig.</i>
<i>Amplifier video 5840-99-946-7733 —circuit</i>	1

#### Introduction

1. Amplifying unit (video) 298 was designed to feed five outputs derived from each of the two video maps ('fine' and 'coarse') to a repeater amplifier, part of selector unit (head) 35, and variants. The input impedance of the amplifier in the selector unit is high, and the output stage of the amplifying unit (video) 298 was designed accordingly.

2. In certain applications, where other equipments are being temporarily integrated, it is necessary to feed the outputs of the video map to a low impedance input circuit of a display unit. The output

stages of the amplifying unit have therefore been re-designed.

#### Circuit description

3. The circuit of the re-designed amplifier (fig. 1) is identical to the circuit of the original amplifier up to the d.c. restorer V11. The re-designed amplifier has only three cathode follower stages in each amplifier chain. The cathode follower valves, V4 to V6, and V12 to V14, have been replaced (CV4055) and the cathode loads have been increased to provide outputs to match the low impedance inputs of the selector unit.

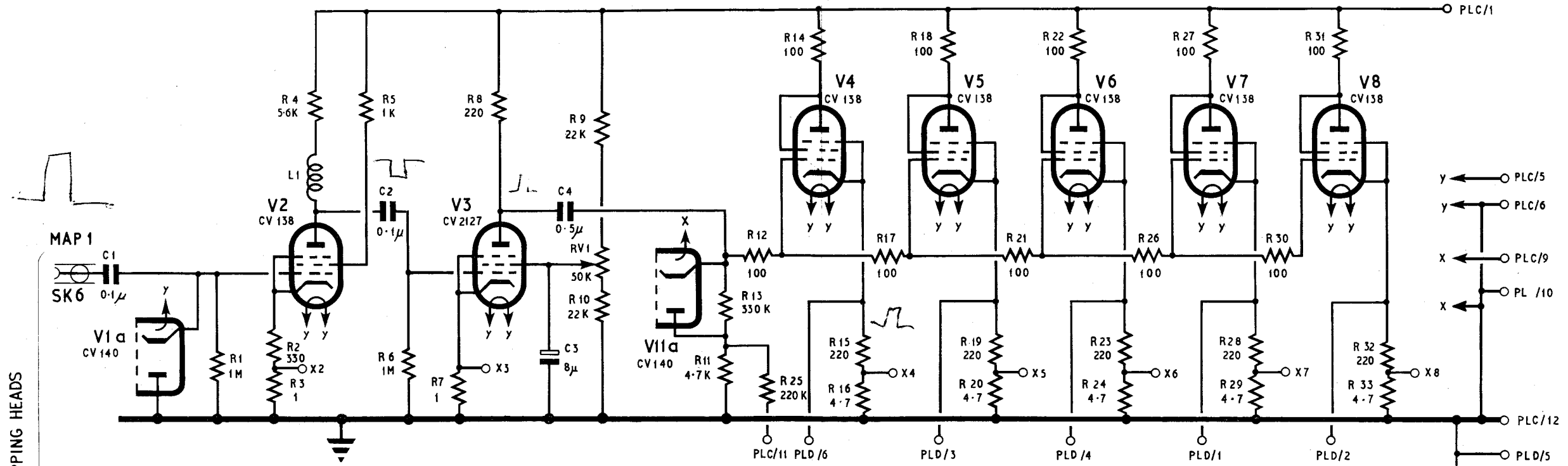

PLC

○ 2	10
○ 4	30
○ 6	50
○ 8	70
○ 10	90
○ 12	110

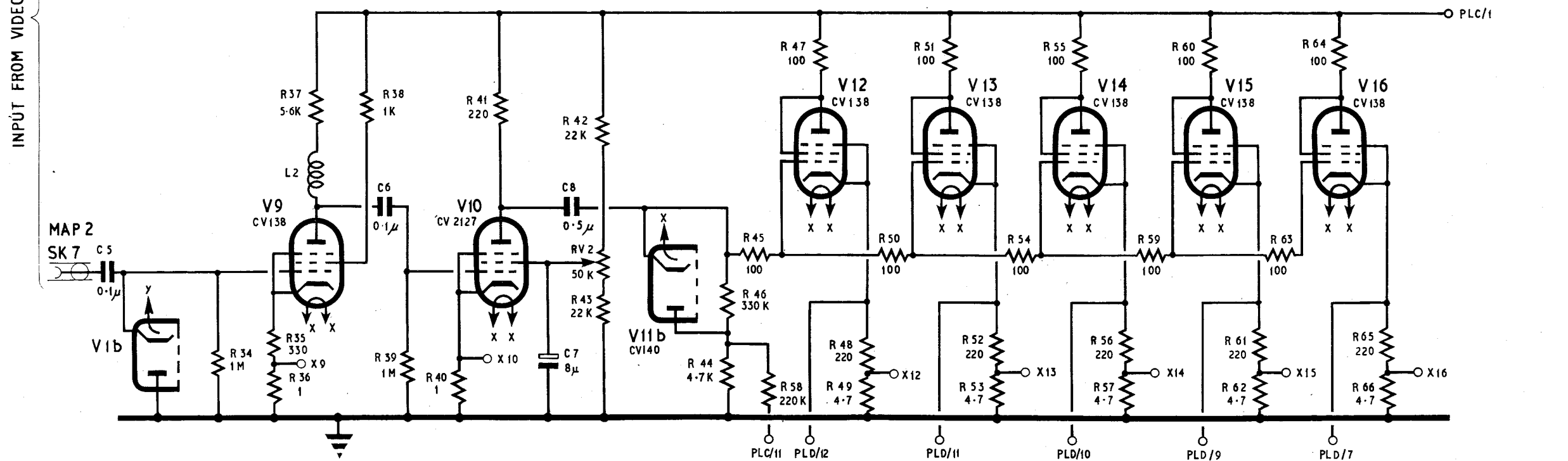
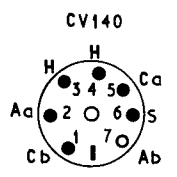
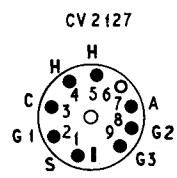
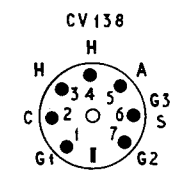

PLD

○ 2	10
○ 4	30
○ 6	50
○ 8	70
○ 10	90
○ 12	110

Fig. 3

Amplifying unit(video) Type 298 - circuit

Fig. 3

439533/48 02 750 6/54 B.B.Ltd. Gp. 979

RESTRICTED

A.L.3, May, 54

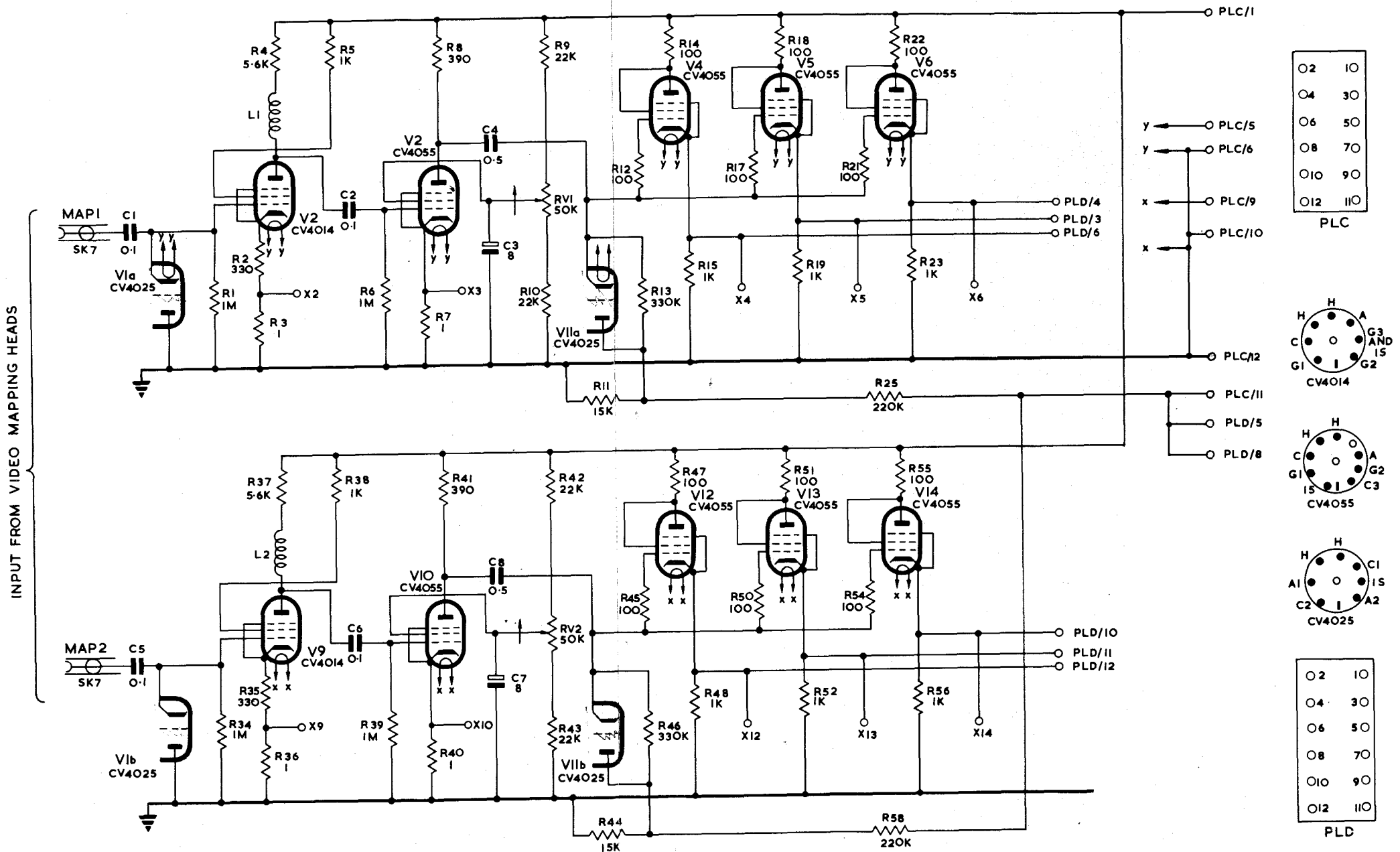

O2	10
O4	30
O6	50
O8	70
O10	90
O12	110

PLC

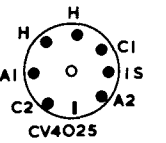
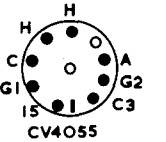
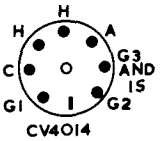

O2	10
O4	30
O6	50
O8	70
O10	90
O12	110

PLD

Fig.1

Amplifier video 5840-99-946-7733 - circuit  
RESTRICTED

Fig.1

Chapter 5

TIMEBASE UNIT TYPE 137 AND 137A

LIST OF CONTENTS

	Para.		Para.
Introduction ... ..	1	Voltage-to-current converter ... ..	22
Circuit description ... ..	2	Trace-brightening waveform generator ... ..	30
Buffer amplifier ... ..	7	Constructional details ... ..	36
Sanatron timebase generator ... ..	8		

LIST OF ILLUSTRATIONS

	Fig.		Fig.
Timebase unit Type 137 and 137A, block schematic ... ..	1	Timebase unit, Type 137 and 137A, front ... ..	4
Waveforms in sanatron... ..	2	Timebase unit Type 137 and 137A, components on rear ... ..	5
Trace brightener waveforms ... ..	3	Timebase unit Type 137 and 137A, circuit ... ..	6

◀LIST OF APPENDICES

	App.
Generator sweep 5840-99-954-8363 ... ..	1▶

Introduction

1. The purpose of the timebase unit is to produce the radial trace on the mapping c.r.t. The timebase unit Type 137 (fig. 6) provides sawtooth outputs

equivalent to 120 or 240 mile ranges. The timebase unit Type 137A (fig. 7) is used in the marker unit (video map) Type 30A to provide a sawtooth output for extra-long-range working. This is

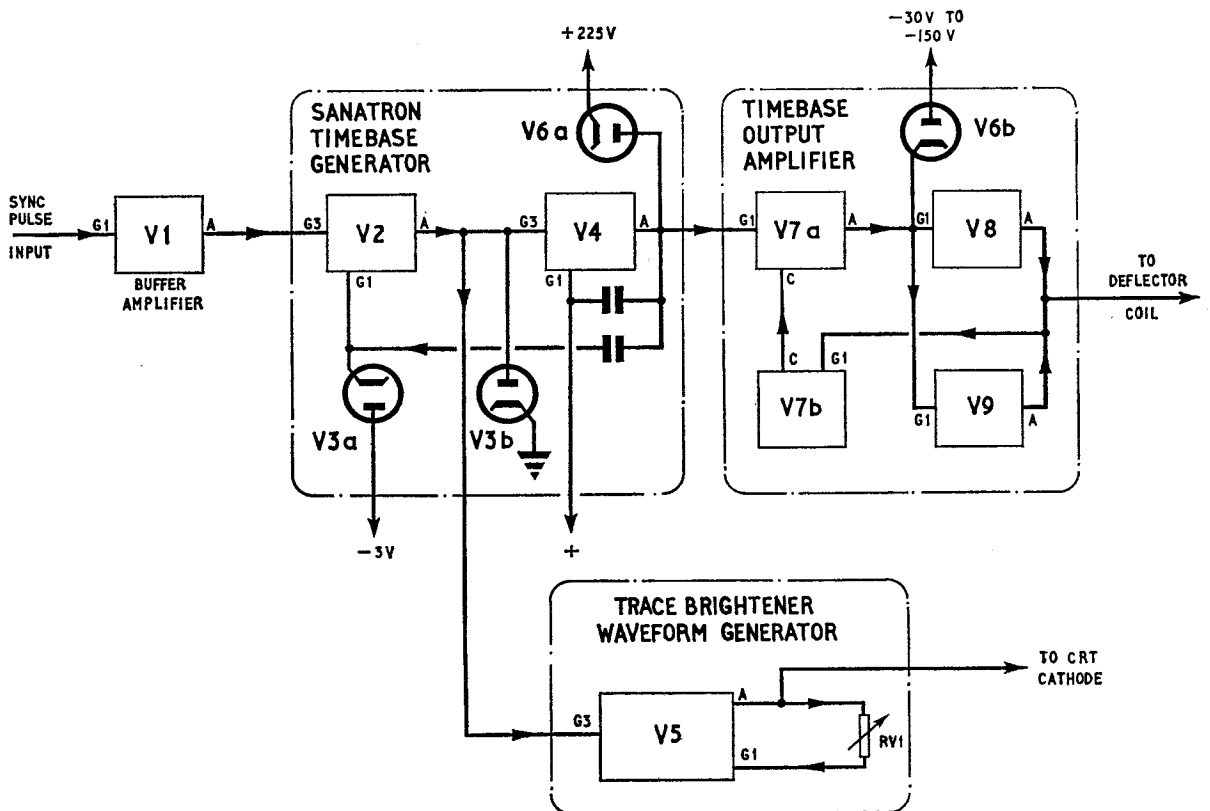

Fig. 1. Timebase unit Type 137 and 137A, block schematic

achieved by circuit changes which enable the controls to be set to give an output equivalent to a range of 320 miles. This output is at half the p.r.f. of the input sync p.r.f. of 250 c/s.

**CIRCUIT DESCRIPTION**

2. In the design of the timebase unit particular care has been taken to ensure the best possible linearity of sweep. The circuit of the timebase unit may be considered to consist of four sections, as indicated in the block schematic diagram, fig. 1.

3. V1 is a buffer amplifier which amplifies the incoming sync trigger pulse and also isolates V2 from the synchronizing source. The timebase generator proper is a sanatron circuit using V2 and V4, the latter being the Miller valve. Three diodes are also associated with this circuit. V3a and V3b are "clamping" diodes, limiting the potentials of the signal-grid of V2 and the suppressor-grid of V4 respectively, whilst V6a is a "catcher" diode which prevents the anode voltage of V4 from rising above a pre-determined value. The function of these diodes will become more apparent when the circuit is described.

4. The output from the timebase generator is applied to a circuit composed of V7, V8, and V9 which functions as a voltage-to-current converter. Its purpose is to convert the linear timebase voltage to a correspondingly linear current for feeding the deflector coil. V7a is a triode amplifier feeding V8 and V9, which are connected in parallel. A negative feedback circuit, using the triode V7b, ensures that the current fed to the deflector coil is a faithful copy of the timebase voltage waveform.

5. The fourth section of this unit is the trace brightening waveform generator V5, which is a type of Miller integrator circuit. It provides the means of brightening the CRT trace at the beginning of the timebase sweep, and also gives a gradual increase of spot brilliance as the spot moves outward from the centre of the screen. The degree of trace brightening is controlled by a potentiometer RV1; the output from V5, in the form of negative-going pulses, is applied to the cathode of the CRT.

6. The action of the timebase will be described with reference to the waveform diagrams, fig. 2 and 3, and the circuit diagram, fig. 6.

**Buffer amplifier**

7. The first stage V1 amplifies the incoming sync trigger pulse and also serves to isolate the timebase circuit from the synchronizing source. The positive-going sync pulse is applied via C1 to the control-grid and appears in amplified form, but with inverted polarity, across the anode load resistor R3. This negative-going pulse (*waveform (a), fig. 2*) is now applied to the suppressor-grid of V2 via condenser C2 and the grid stopper R6.

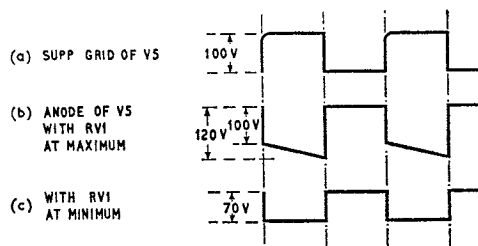

**Fig. 3. Trace brightener waveforms**

**Sanatron timebase generator (V2, V3, V4, V6a)**

8. The timebase waveform is produced by two CV138 pentode valves, V2 acting as an electronic relay controlled by the trigger pulse from V1 which is applied to its suppressor-grid, whilst V4, controlled by V2, produces the characteristic anode voltage "run-down" of the well-known Miller type timebases. This linear run-down of the anode voltage of V4 is used to provide the linear sweep of the timebase output waveform.

**Note . . .**

*In the description that follows, the switch SW1 is assumed to be in the position shown in the circuit diagram, fig. 6.*

9. When the circuit is in a quiescent condition both V2 and V4 are passing control-grid current, since they both connected to a point of positive potential derived from the potential divider RV3 connected across the HT supply. The anode voltage of V2 is "bottomed," i.e. has fallen below the bend in its  $I_a-V_a$  characteristics, whilst V4 is cut off by a negative bias applied to its suppressor-grid. The magnitude of this negative bias voltage is determined by the potential divider network R8, R10, R12 across which is developed 600 volts DC, since the network is connected between HT+ (+300 volts) and the -300 volt line.

10. Under these conditions the anode voltage of V4 would tend to increase to full HT potential, but it is held at approximately 225 volts by the action of the catcher diode V6a. This controlling action of V6a will be described more fully at a later stage. The absence of anode current in V4 thus causes C4 and the parallel combination C5, C6, to charge to the "caught" HT potential of approximately 225 volts as the anode voltage increases, exponentially, to this value.

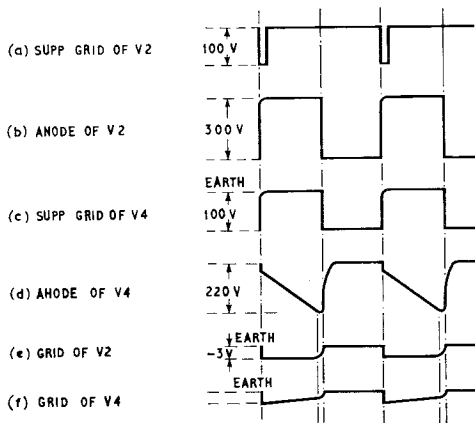

**Fig. 2. Waveforms in sanatron**

11. When the negative-going sync pulse is applied to the suppressor-grid of V2, its anode voltage begins to rise and this increase is passed via C3 and R10 to the suppressor-grid of V4. The negative bias on this grid is reduced, V4 conducts and its anode voltage falls ; this fall is passed to the control-grid of V2 via C4, reducing the positive potential and therefore augmenting the effect of the originating trigger pulse. The cumulative effect of a series of these operations, occurring almost instantaneously, is an almost instantaneous increase of V2 anode voltage (*Waveform (b) of fig. 2*) to 300 volts and complete neutralization of the negative bias on the suppressor-grid of V4.

12. A high anode current now flows through R21 and R22 and the anode potential of V4 falls. Owing to the p.d. across R22, however, the anode potential of V4 falls lower than the anode of the diode V6a ; since the condenser C4 is connected to the anode of V4 and C5-C6 are connected to the anode of V6a, the control-grid potential of V2 falls below the control-grid potential of V4 ; the fall is in fact sufficient to cut off the anode current of V2.

13. The effect of C5-C6 however, connected between anode and control-grid of V4, is to slow down the rate of fall of anode voltage of V4 and a linear run-down of this voltage occurs (*waveform (d) of fig. 2*) whilst at the same time current flows into C5-C6 via R16, R17, R18, R19 and RV3. The negative control-grid bias of V4 at any instant during this discharge of C5-C6 is equal to the difference in the voltage between (a) R31, part of RV3 and earth and (b) the voltage developed across R16, R17, R18, and R19 by the condenser discharge current. As C5-C6 discharges the anode voltage falls ; for the valve to maintain a constant anode current, therefore, reduced control-grid bias is necessary. This is provided automatically by feedback from anode to control-grid of V4 via C5-C6. However, since the total resistance of R16, R17, R18 and R19 is large, this reduced control-grid bias can be obtained by a very small reduction in the current flowing through R16, R17, R18, and R19, hence this current falls only very slightly as the condenser discharges.

14. The progressive fall of grid voltage (*waveform (f) of fig. 2*) which occurs during the anode run-down, has practically no effect upon the current flowing into C5-C6. These are, therefore, being charged from an almost constant current source, and the voltage across them varies linearly with respect to time. Since this voltage controls the run-down, the anode voltage fall will also be linear. The potentiometer RV3 gives fine control of the timebase period by variation of the grid discharge potential.

15. As the linear run-down of the anode potential of V4 continues, it reaches a point just above cathode potential where the valve "bottoms" and the voltage ceases to fall. In the absence

of feedback via C5-C6 the control-grid potential of V4 commences to increase to the value at the set point on RV3, but grid current flow holds it at cathode potential.

16. At the same time, the control-grid of V2 also tends to rise to a positive potential, but after rapidly overcoming its negative bias voltage of -3 volts, it remains at cathode potential due to grid current flow. The anode voltage of V2 falls, and this fall is transferred via R10 and C3 to the suppressor-grid of V4 ; there is a corresponding increase of anode voltage at V4 which is passed back via C4 to the control-grid of V2, augmenting the original increase. This sequence, occupying only a very short time, results in V2 becoming conductive and the suppressor-grid of V4 once again being returned to a negative potential, cutting off the anode current of V4. The anode potential of V4 rises exponentially towards 300 volts but it is caught at approximately 225 volts by the catcher diode V6a (*waveform (d) of fig. 2*) and C4 is charged to the same potential, as are C5-C6 also. The circuit has now completed a full cycle of operations and remains quiescent until a further sync pulse arrives.

17. The diode V3a prevents the control-grid of V2 from being taken excessively negative by the fall of anode potential of V4. This fall is of the order of 200 volts, and if the control-grid of V2 were taken so far negative it would take a considerable time at the end of the timebase stroke to rise to conducting point. The anode of V3a is held at -3 volts by the potential divider R14, R13, and since the cathode of V3a is connected to the junction of R9 and R11, the potential of this junction is caught at -3 volts also. There is, therefore, minimum delay at the end of the timebase stroke before the recovery action occurs.

18. The function of V3b is to prevent the suppressor-grid of V4 from being driven above earth potential by the incoming positive-going pulse from V2. The diode cathode is earthed, and if its anode rises above this point due to the output from V2 it immediately conducts and returns the suppressor-grid to earth potential.

19. The action of the catcher diode V6a is as follows. At the commencement of the cycle of operations the anode of V6a is slightly above its cathode potential, this potential being fixed by the potential divider R33, R34 across the HT supply. As soon as the anode voltage of V4 falls (at the beginning of the Miller run-down) V6a is cut off and does not, therefore, affect the timebase sweep in any way. At the end of the sweep, however, V4 is cut off and its anode potential begins to rise exponentially owing to the charging action of C4 and C5-C6 via R21. It rises rapidly over the first part of the exponential climb for about 75 per cent of its "normal" recharge voltage ; a much longer time is taken in rising through the remaining 25 per cent of the HT voltage. The cathode V6a, however, is held at a

point which is approximately 75 per cent of the recharging potential (i.e. the HT voltage) by the value of R33 and R34. The re-charge ceases as soon as this point is reached, since V6a becomes conductive, and by this means the circuit recovery time is shortened without undue loss of timebase sweep.

**20.** The DC feed resistors to the screening-grids of the valves in this section of the unit are R2, R7 and R50. R55, R56, and R57 are shunt resistors for the meter which may be connected between the test points X1, X2, and X3, and earth.

**21.** Extra-long-range version. In the above description of the timebase generator it is assumed (see Note) that the switch SW1 is in the 240M position. With the Type 137A timebase unit the switch SW1 would be set to the LR position for extra-long-range operation. The potentiometer RV2 would then give fine control of the timebase period. Unfortunately, the range cannot be set to exactly 320 miles. This is because the time taken for the timebase to run-down, at this range, coincides with the sync pulse interval. There is no time for the timebase to recover and so instability results. The range set by RV2 must therefore be just under or just over the nominal 320 mile range.

#### **Voltage-to-current convertor (V6b, V7, V8, V9)**

**22.** To provide the necessary timebase trace on the CRT the current which passes through the deflector coil must increase linearly with the linear fall of timebase voltage. V8 and V9 are used in parallel so that the deflector coil current, which is the sum of the anode currents of these two valves, will be adequate. The deflector coils are shunted across R42, in the anode circuit of V8, V9, so that anode current still flows if the coils are disconnected at SK.8, SK.9.

**23.** The output from the timebase generator V2, V4, is developed across R32 (with C8 in parallel) RV4 and R39. C8 is connected across R32 to give high-frequency compensation for the effect of stray capacitance existing across the input circuit of the triode V7a. The potentiometer RV4 controls the amplitude of the timebase voltage applied to the control-grid of V7a.

**24.** This triode operates purely as an amplifier and applies the amplified, but now inverted, timebase pulses to the parallel-connected grids of V8 and V9 via C11 and grid-stoppers R43, R44. The anode currents of V8 and V9 now vary with the amplified timebase voltage applied to their control-grids, and since this waveform has already been inverted in V7a, the anode currents of V8 and V9 passing through the deflector coil will be an exact, but inverted, copy of the output voltage of V4.

**25.** The second triode V7b forms part of a feedback circuit which ensures (a) that a perfectly linear current variation is produced in the deflector coil for a linear timebase sweep and (b) that the tendency to non-linearity due to the inductance

of the coil is neutralised. The small resistor R52 is connected in series with the deflector coil in the anode of V8 and V9, and hence all current passing through the coil will also flow through R52.

**26.** The voltage appearing across this resistance is fed back via C12 to the control-grid of V7B, and since R52 is low compared to the total resistance of the output circuit (composed of the coil resistance plus the internal resistances of V8 and V9) the feedback voltage is directly proportional to the magnitude of the deflector coil current. V7a and V7b have a common cathode circuit so that the feedback to V7a is negative, and changes of deflector coil current will therefore result in proportional, but anti-phase, voltage variations at the signal grid of V7a. The deflector coil current is therefore constrained to follow the timebase voltage at the grid of V7a, since these two quantities are, in effect, locked together.

**27.** Under static conditions when the timebase generator is not working, no deflection current must flow in the deflector coil, and therefore V8 and V9 are biased beyond cut-off by a standing negative voltage. This is derived from the potential divider network R47, RV5, R48 connected across the -300 volt supply. When these valves are cut off there is no negative feedback to V7a and consequently this stage will operate at high gain. When, therefore, a voltage is applied to V7a control-grid at the start of the timebase sweep the gain is such that the anode voltage of V7a rises almost instantaneously (in the order of 5 microseconds) and swings the control-grids of V8 and V9 from their standing negative bias value up to conduction point.

**28.** The diode V6b is a DC restorer, the anode being held at a negative potential which is the same as applied to the control-grids of V8 and V9 under quiescent conditions. If V6b were omitted, the residual charge of C11, at the end of the timebase cycle, would cause the control-grids of V8 and V9 to become more negative than this quiescent value, and the recovery time of V8 and V9, would be increased. The presence of V6b prevents this.

**29.** The valves V8 and V9 have grid stopper resistors R43 and R44 and also anode stoppers R41 and R46. R40 and R54 are the cathode bias resistors for V8 and V9 respectively and R60 and R61 are shunt resistors for the meter used in conjunction with the test points X6 and X7.

#### **Trace-brightening waveform generator (V5)**

**30.** If for any reason the timebase generator is not working, the electron beam of the CRT must be cut off. When the timebase is operating normally, it is necessary at the beginning of the timebase stroke for the trace to be brought up to normal brilliance. The stage containing V5 is designed to accomplish this and also, if required, to provide a slightly increasing brilliance as the trace moves outward from the centre of the tube. The operation of the stage is based upon that of a Miller integrator circuit of longtime constant.

31. Under quiescent conditions the suppressor-grid of V5 is held at a steady negative voltage from the same source as the suppressor-grid of V4, and consequently V5 is non-conducting. A positive-going pulse, generated in the sanatron circuit when the timebase commences to operate, is applied via R10 and R23 to the suppressor-grid of V5 overcoming the negative bias and allowing anode current to flow. The immediate effect is that the anode voltage of V5 begins to fall. A proportion of this decrease (one-sixteenth, since R25 is 1K and R26 is 15K) is fed back to the control-grid of V5 via C7, R28 and R27.

32. The control-grid, however, is connected via R27, R29a and R29b to a point of positive potential derived from the potential divider RV1, R49 connected across the HT supply. The grid is, therefore, conducting and the grid circuit presents a low resistance; the voltage fed back via C7 will not, then, have much effect upon the grid potential. The anode potential continues to fall very rapidly, the feedback voltage becomes greater and the grid is gradually driven toward grid current cut-off as the feedback voltage increases. The balance condition is reached when the anode current value is such that in flowing through R25 it produces a voltage which when fed back to the signal grid reduces the grid potential to the point at which this amount of anode current is permitted to flow.

33. When this balance condition is reached, C7 commences to discharge and this arrests the rapid fall of anode voltage. It continues to fall linearly with very slight slope, and in fact performs the wellknown Miller run-down. The rate of the superimposed slope can be adjusted by the potentiometer RV1, as shown at (b) and (c) of fig. 3. With RV1 set at minimum the run down is so slow as to be imperceptible and the output waveform is virtually a square wave.

34. The output from this stage, taken from the

anode of V5, is a negative-going pulse and is applied to the cathode of the CRT. Thus, the first rapid fall of anode voltage will bring the CRT trace up to normal brilliance, whilst the following gradual decrease will give a radial increase of brilliance to a degree dependent upon the setting of RV1.

35. At the end of the positive pulse on its suppressor-grid, the anode current of V5 is cut off; the anode voltage then rises exponentially to its "waiting" value, charging C7, and awaits the next timebase cycle.

### CONSTRUCTIONAL DETAILS

36. Fig. 4 shows the front view of the timebase units Type 137 and 137A. The valves of the unit are mounted in sequence across the middle of the panel, with the buffer stage valve V1 on the extreme right-hand side. Directly below the valves are the test sockets associated with them. The pre-set potentiometers along the top of the Type 137 unit, RV1 to RV5, are the controls for BRILLIANCE COMP., 120M RANGE, 240M RANGE, SWEEP, and ZERO SET respectively. The potentiometer RV2 in the Type 137A unit is labeled 320M RANGE. Also at the top of the unit is the range switch SW1. This switch selects the 120M or 240M range (Type 137) or 320M or 240M (Type 137A). SK8 and SK9 are the timebase output terminals to the CRT deflector coil, SK11 is the sync input terminal, and SK10 the output of the trace brightener valve. The Jones plug PLF carries the standing voltages such as HT supply heater supplies, and a -300-volt supply, from the appropriate power packs.

37. The rear of the timebase unit is shown in fig. 5; it will be seen that the majority of resistors and capacitors are carried on two tag-panels, one above and one below the valve-bases. The resistor R49, marked with an asterisk, is only fitted to the timebase unit Type 137A.

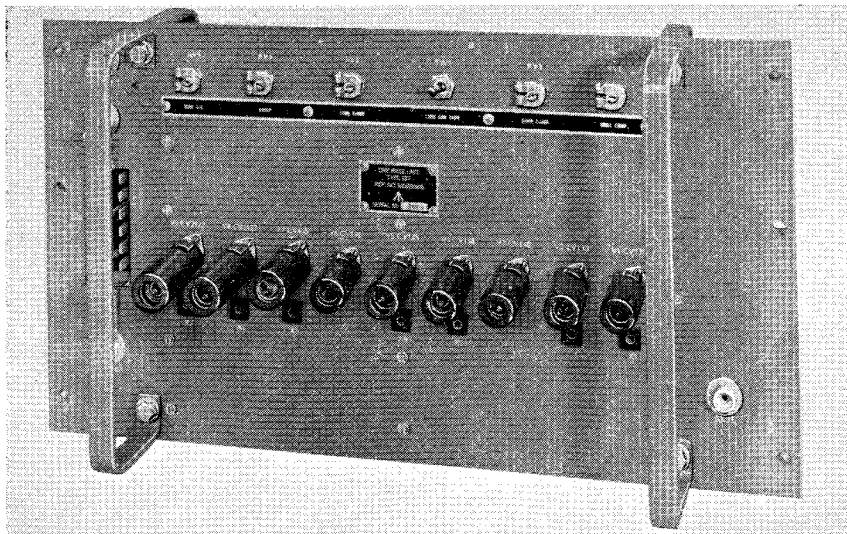

Fig. 4. Timebase unit, Type 137 and 137A, front

RESTRICTED

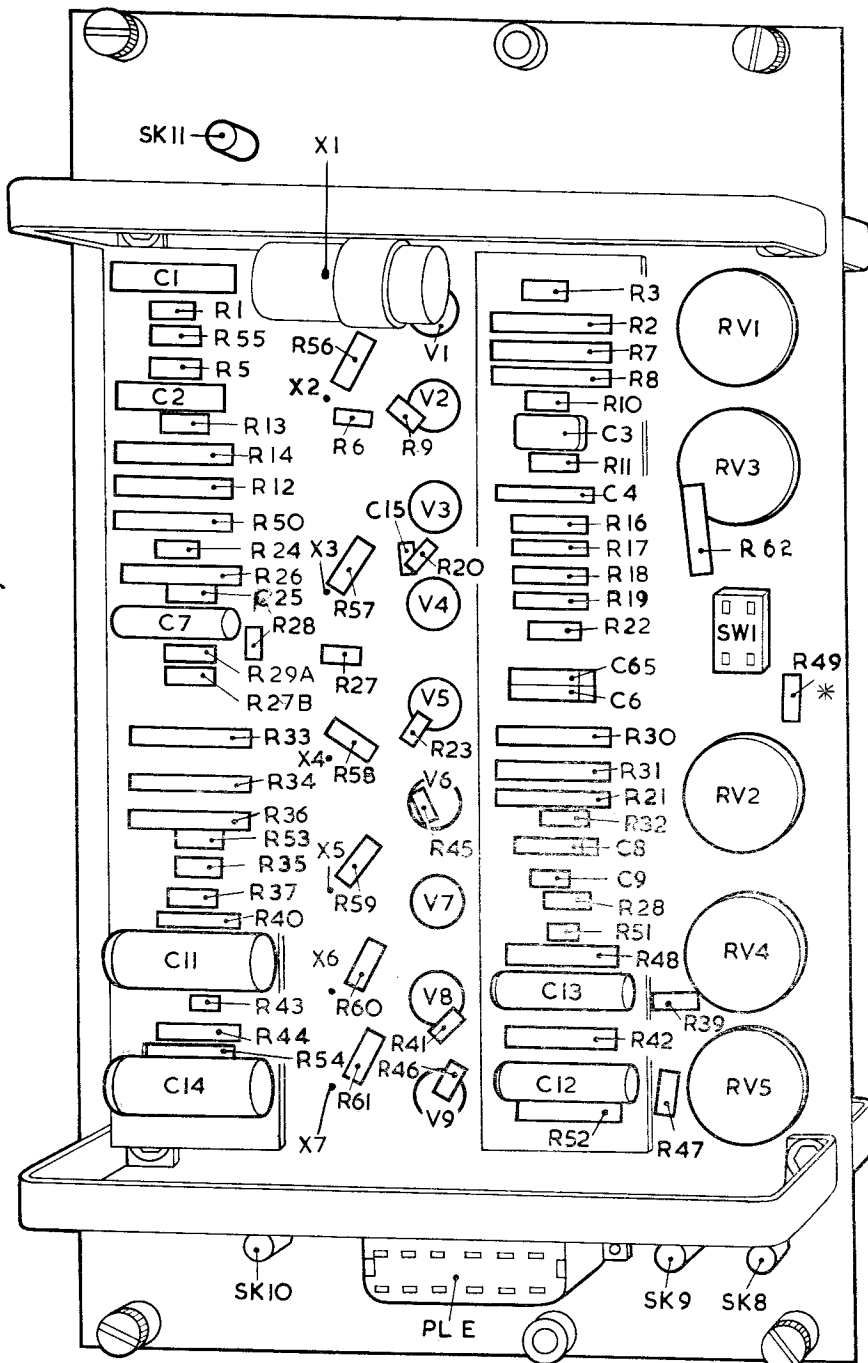
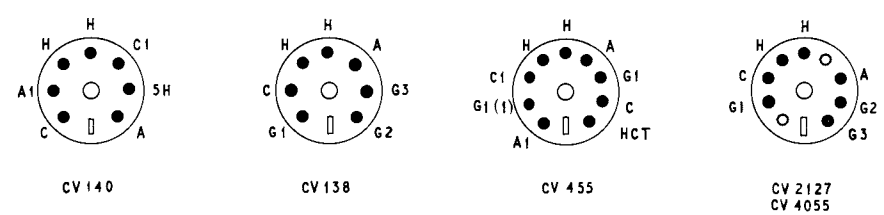
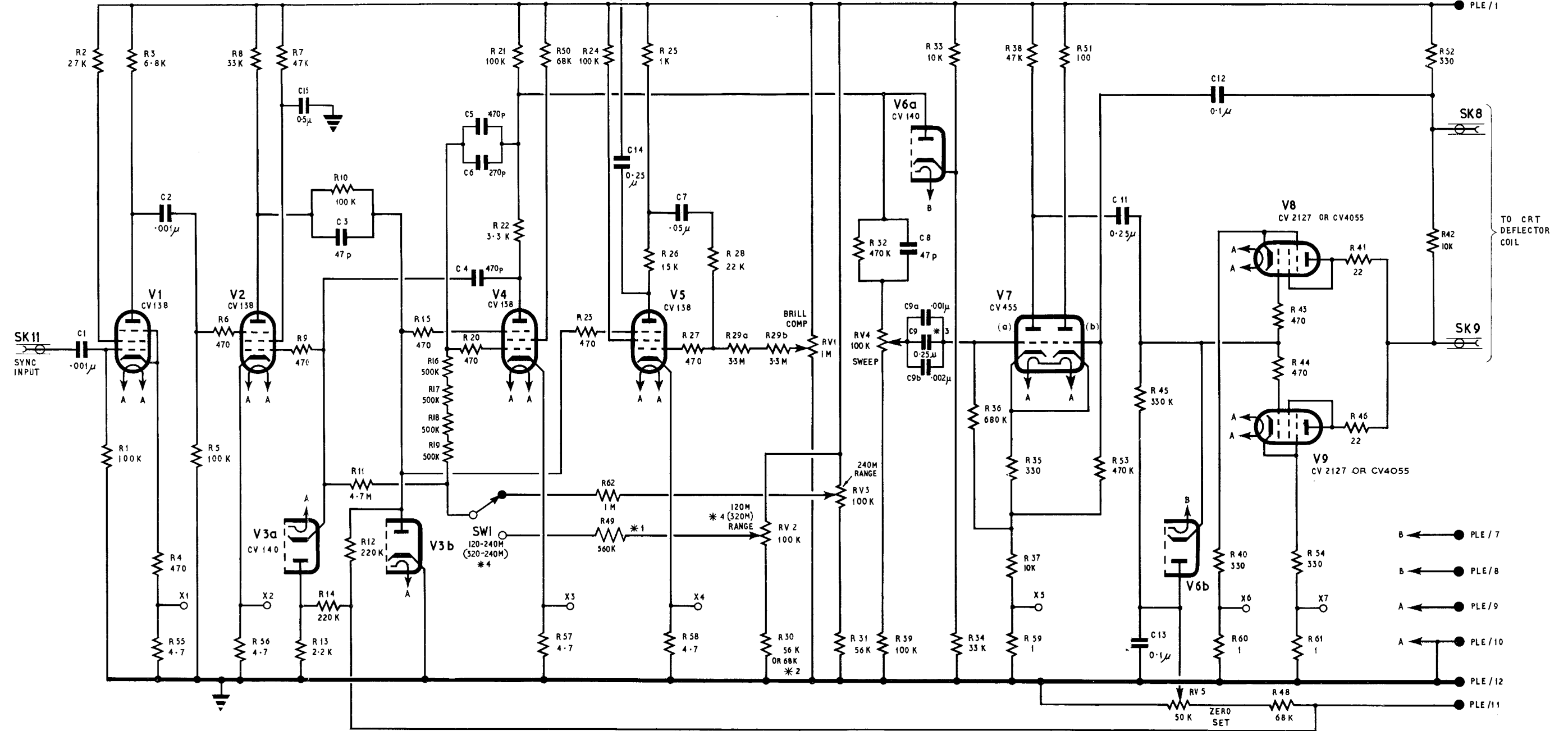

Fig. 5. Timebase unit Type 137 and 137A, components on rear

RESTRICTED



- \* NOTES:
1. R49 FITTED IN I37A ONLY
  2. R30 VALUE IS 56K (I37A) 68K (I37)
  3. C9 IS FITTED IN I37A, C9a AND C2b ARE FITTED IN I37.
  4. THE RANGES OF THE I37A ARE 240M AND 520M.
  5. CV4055 TO BE USED AS A REPLACEMENT FOR CV2127 ONLY IF MOD.1. HAS BEEN CARRIED OUT TO TYPE I37, OR MOD.2. TO TYPE I37A

Fig. 6

Timebase unit Type I37 and I37A - circuit

Fig. 6

**Appendix 1**  
**GENERATOR SWEEP**  
**5840-99-954-8363**

**CONTENTS**

	<i>Para.</i>
<b>Introduction</b> ... ..	1
<i>General</i> ... ..	2
<i>Circuit description</i> ... ..	3
<i>Gating circuit</i> ... ..	4

**LIST OF ILLUSTRATIONS**

	<i>Fig.</i>
<i>Generator sweep: scrap component layout</i> ...	1
<i>Generator sweep 5840-99-954-8363: circuit</i> ...	2

**INTRODUCTION**

1. The generator sweep 5840-99-954-8363 is a modified timebase unit 137A in the cabinet electrical equipment 5975-99-954-8498 described in Part 1, Chap. 1, App. 1.

**General**

2. The timebase unit 137A is modified to a generator sweep 5840-99-954-8363 by the addition of a monostable multivibrator, VT1 and VT2 (fig. 2), and its associated components and a socket SK23. The components are mounted on a bracket mounted tagboard as shown in fig. 1.

**Circuit description (fig. 2)**

3. The buffer amplifier (V1), the sanatron timebase generator (V2, V3, V4, V6a) and the voltage to current converter (V6b, V7, V8, V9) operate in an identical manner to those in timebase unit Type 137A. The gating circuit (VT1, VT2), which controls the triggering of sweep generator circuits is described below.

**Gating circuit (VT1, VT2)**

4. The two transistors VT1 and VT2 and associated components form a monostable multivibrator, the input of which is a half rate p.r.f. sync entering at SK23. When a half rate p.r.f. sync pulse is applied to the base of VT1 via the differentiating and limiting circuit (R70, R71, C18, V10, V11, V12), VT1 starts to conduct, switching VT2 off, and the voltage at VT2 collector drops from earth potential to -20V. This -20V level appears at the suppressor grid of V1, holding this valve in the cut-off condition for approximately 5 ms.

5. Since the repetition rate of the sync pulses at SK11 is twice that of the monostable trigger pulses, alternate sync pulses at SK11 are amplified at V1 and used to trigger the sanatron timebase generator. The outputs of the sweep generator are, therefore, at half the rate of the sync pulses at SK11 and are suitable for timing the Type 85 radar marker unit circuits in the cabinet electrical equipment 5975-99-954-8498.

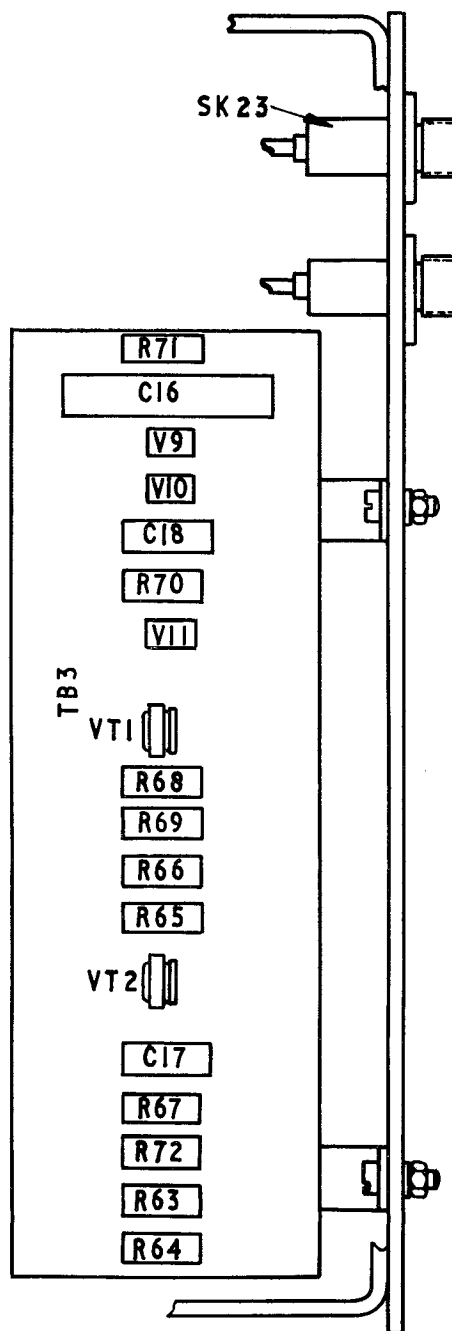
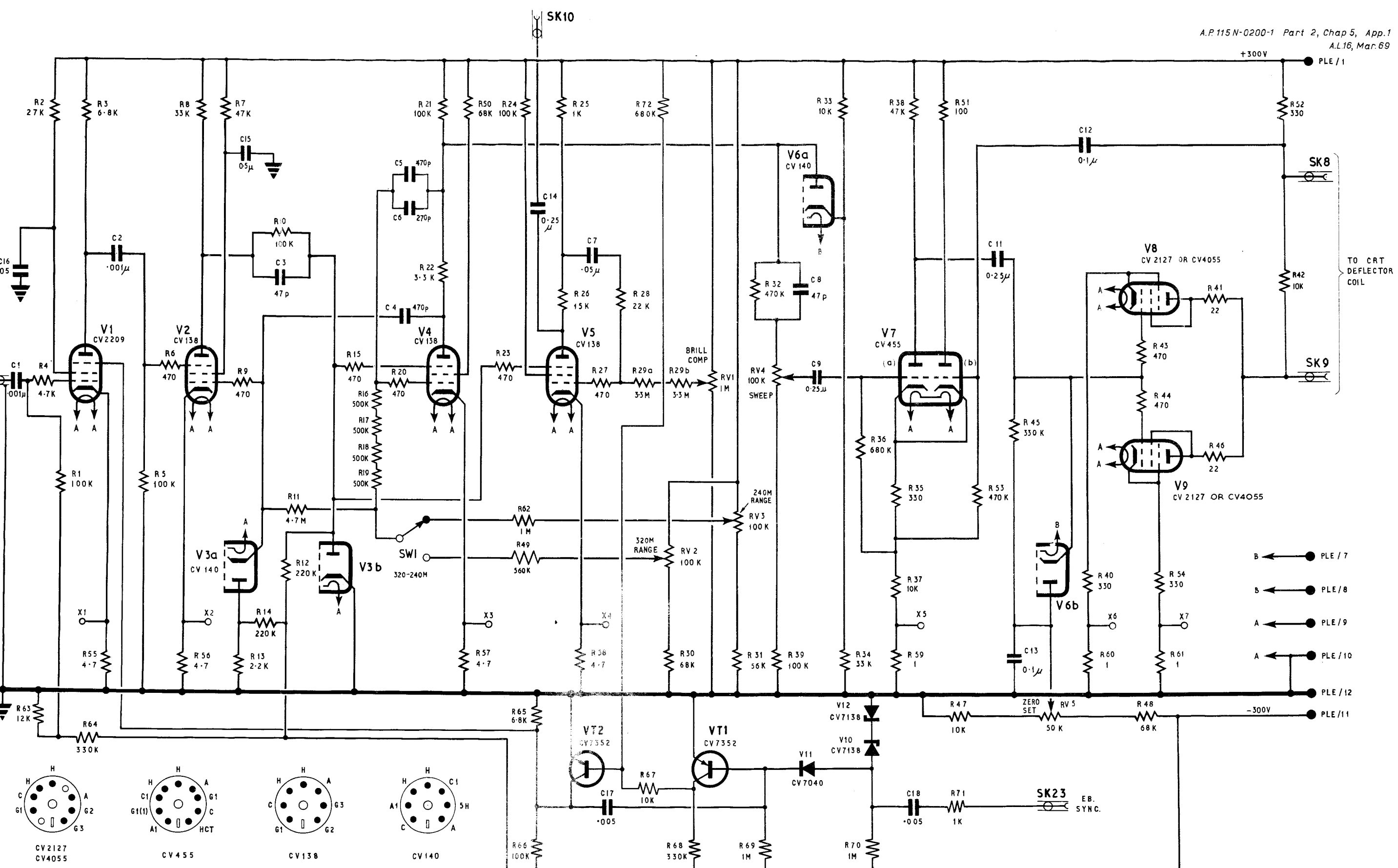

Fig. 1. Generator sweep: scrap component layout



Generator, Sweep 5840-99-954-8363 : circuit

Fig. 2

## Chapter 6

### POWER UNITS, (-300V) TYPE 884 AND (+300V) TYPE 885

(This Chapter supersedes Chapter 6 issued with A.L.12)

#### LIST OF CONTENTS

	Para.
<b>Power unit (-300V) Type 884</b>	
<i>Circuit description</i> ... ..	1
<i>Construction</i> ... ..	11
<b>Power unit (+300V) Type 885</b>	
<i>Circuit description</i> ... ..	12
<i>Construction</i> ... ..	17

#### LIST OF ILLUSTRATIONS

	Fig.		Fig.
<i>Power unit (-300V) Type 884</i> ... ..	1	<i>Power unit (+300V) Type 885</i> ... ..	4
<i>Power unit (-300V) Type 884, circuit</i> ...	2	<i>Power unit (+300V) Type 885, circuit</i> ...	5
<i>Power unit (-300V) Type 884, components on rear</i> ... ..	3	<i>Power unit (+300V) Type 885, rear</i> ...	6

#### POWER UNIT (-300V) TYPE 884

##### Circuit description

1. In several units of the marker unit (video map) Type 30 it is necessary to provide negative voltages for various purposes, e.g., the cathode voltage on

V2, controlling focus coil current in the scanning assembly. Power unit Type 884 provides an output of -300 volts which is fed to these units where required. In addition, the outputs from the other four power racks are brought to this unit and switching is provided so that the outputs from any

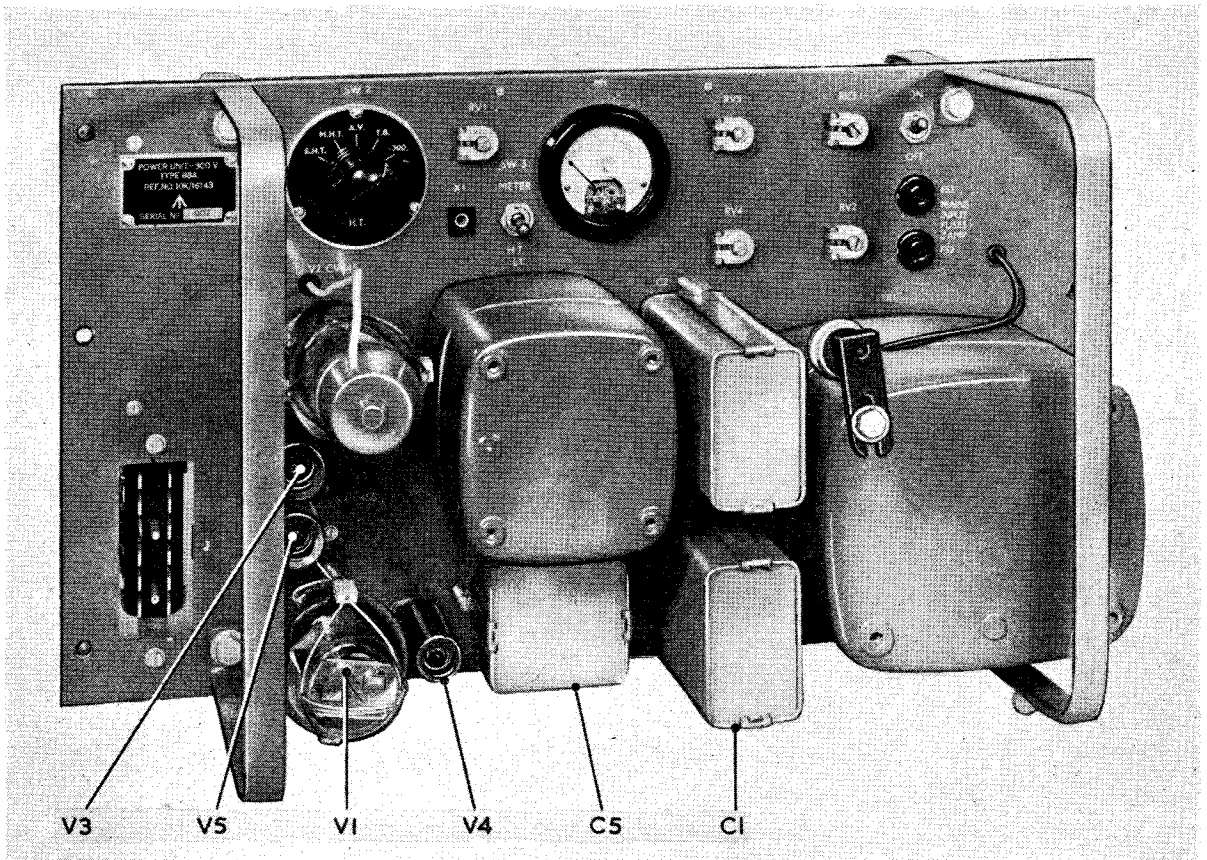

Fig. 1. Power unit (-300V.) Type 884

**RESTRICTED**

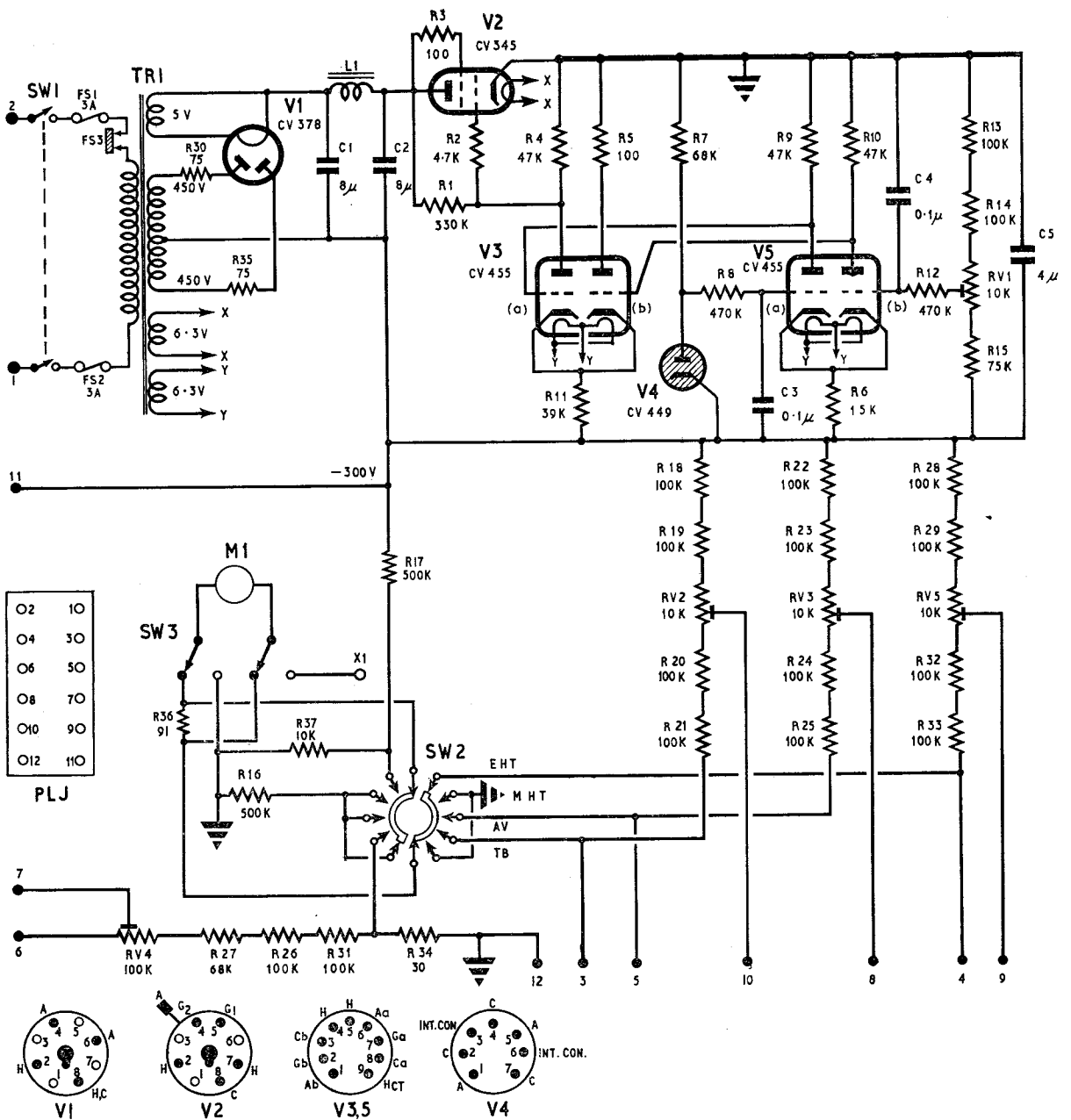

Fig. 2. Power unit (—300V) Type 884, circuit

one of them, at will, may be metered and adjusted. The circuit diagram is given in fig. 2.

2. The mains input from plug PLJ is fed to a conventional full-wave rectifier circuit via the transformer T.1. This has four secondary windings, the three low-voltage windings feeding the heater of the rectifier V1, the heater of the regulator valve V2 and the stabilizer valves V3 and V5 respectively. The remaining winding is a centre-tapped HT winding feeding the anodes of the rectifier valve V1. The output from V1 is applied across the reservoir condenser C1, and the AC ripple on the rectified output is filtered out by the choke L1 and the condenser C2. To provide a negative output, the heater of V1 is earthed via

V2 and the output line is taken from the centre-tap of the HT winding of T1.

3. The output from the smoothing network is fed to the valve V2 which operates as a current regulator valve, the total output current drawn from the rectifier circuit passing through it. The cathode of V2 is earthed so that the output from this unit is negative with respect to earth. The function of V2 is to provide stabilization of the output of the unit and this is achieved by regulating the control-grid potential of V2, and hence the anode current (which is the output current), from a stabilizer circuit composed of two double triodes V3 and V5, and a neon stabilizer V4.

RESTRICTED

4. A potential divider network is connected directly across the  $-300$  volt output of the unit, and is decoupled by condenser C5. A potentiometer RV1 allows a certain adjustable proportion of this voltage to be tapped off and applied to the control-grid of triode V5(b). The control-grid of V5(a) is held at a steady potential of some 80 volts by the action of the neon stabilizer V4 connected with its series resistor R7 across the full HT voltage. The anodes of V5(a) and V5(b) are connected to the control-grids of triodes V3(a) and V3(b) respectively.

5. When the output voltage from the unit is correct, under load conditions, the slider of RV1 is adjusted so that the voltage applied to the control-grid of V5(b) is exactly equal to the stabilized voltage at the control-grid of V5(a). This latter voltage is the "reference" voltage, and the operation of the stabilizer circuit is based upon the fact that the output voltage (or in actual fact a selected proportion of it) can be compared with this constant voltage; any difference between these two values brings the stabilizer into operation.

6. If the voltages at the two control-grids of V5 are equal, the anode currents of the two sections of the valve will be equal, as will be the control-grid potentials of V3(a) and (b), so that a balance condition exists in the circuit. An increase of output voltage across C5, for any reason, will cause the control-grid potential of V5(b) to become more positive and its anode potential will fall. At the same time the potential of the common cathode will also become more positive, but since the control-grid is held at a constant voltage by the neon stabilizer V4, the anode voltage will effectively become less positive with respect to the cathode, and the anode current of V5(a) will fall. The effect of these changes upon V3 is that the control-grid potentials will become unbalanced, the control-grid of V5(b) becoming less positive and the control-grid of V5(a) becoming more positive. The increase in potential of this latter grid is augmented by the fact that the common cathode is less positive in potential due to the fall in potential of V5(b) grid.

7. The anode current in V5(a) will now increase, as will the voltage drop across R4. This reduces the potential of the grid of the current regulator valve V2, effectively causing its resistance to increase, and the output voltage across C5 will fall to a corresponding degree; when this voltage has fallen to the point where the potential of the control-grid of V5(b) again equals that of V5(a), the balance condition is restored in V5. Any changes in the voltage at the output terminals of the unit therefore give rise to a proportional but opposite voltage at the control-grid of V2, and the action of this valve keeps the output voltage constant.

8. The outputs from the power packs supplying the timebase, video amplifier, and EHT power unit are brought into the power unit Type 884 via the plug

BLJ. Each one is connected via a network consisting of four fixed resistors and a potentiometer (for example, R18, R19, RV2, R20, R21), which in effect are connected across the incoming positive 300-volt line and the common negative 300-volt line, the tapping on the potentiometer being taken back to the same positive 300-volt unit to serve as the control bias.

9. The incoming lead from each positive 300-volt unit is also taken to switch points on the switching circuit for the meter M1. In a similar manner, the output from the MHT power unit Type 883 is taken into the  $-300$ -volt power unit and to earth through a chain of resistors RV4, R27, R26, R31, R34, and is similarly connected to the meter switch (SW2). This switch connects the output from any desired power pack (or a tapped-down sample thereof in the case of the MHT unit) across the meter M1, when the switch SW3 is in the HT position.

10. The output from each of the four units so metered can be adjusted by setting the control bias of the unit by means of the associated potentiometer, the latter being accessible from the front panel, although of the pre-set type. RV2 controls No. 1, RV3 controls No. 2, and RV5 controls No. 3, of the three positive 300-volt units, while RV4 controls the MHT unit. The switch SW3, when set at METER, connects the meter directly between the socket X1 and earth, so that it can be used to monitor external circuits. The output of the unit itself can be metered by putting SW2 to the position " $-300$ ."

### Construction

11. Front and rear views of the power unit, showing the location of all components, are given in fig. 1 and 3. The heavy components such as the transformer and the choke L1 are mounted on the front panel, and the smaller ones on the rear.

### POWER UNIT (+ 300V) TYPE 885

#### Circuit description

12. Three power units Type 885 are used in the marker unit. No. 1 provides a stabilized HT supply to the timebase unit Type 137, and also for the regulator valve in the power unit (MHT) Type 883. No. 2 provides similar supplies for the amplifying unit (video) Type 298, the relay RL.1 in the switch unit Type 504, the centring coils in the indicating unit Type 33, and the photo-electric unit Type 100. No. 3 has only one function, i.e. to provide the positive HT supply for the valves in the power unit (EHT) Type 882.

13. The circuit diagram is shown in fig.5. The mains transformer TR1 has four secondary windings, three of which are low voltage ones, feeding the directly-heated rectifier valve V1, the regulating valve V2; and the stabilizer valve V3, respectively. The high-voltage winding (450-0-450) is centre-tapped to earth and feeds the full-wave rectifier V1. The DC output is developed across

0027/70-7642-336-2/73-MTL-1683

RESTRICTED

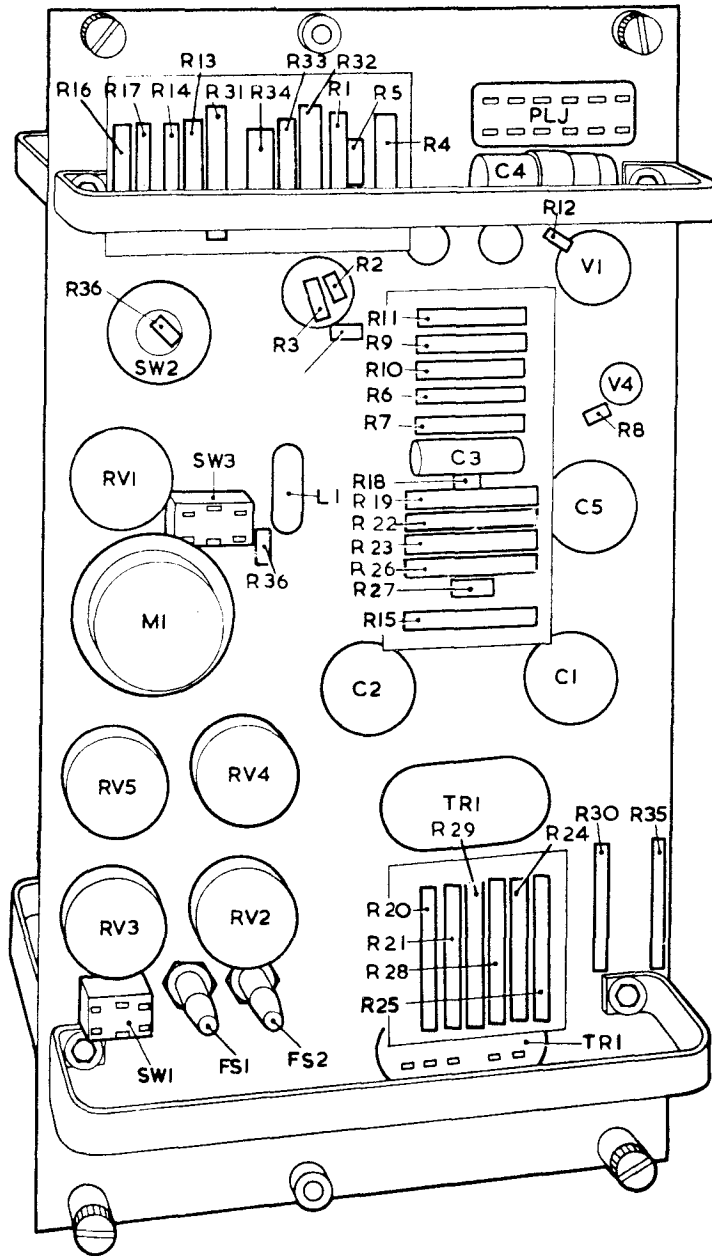

Fig. 3. Power unit (-300V) Type 884, components on rear

RESTRICTED

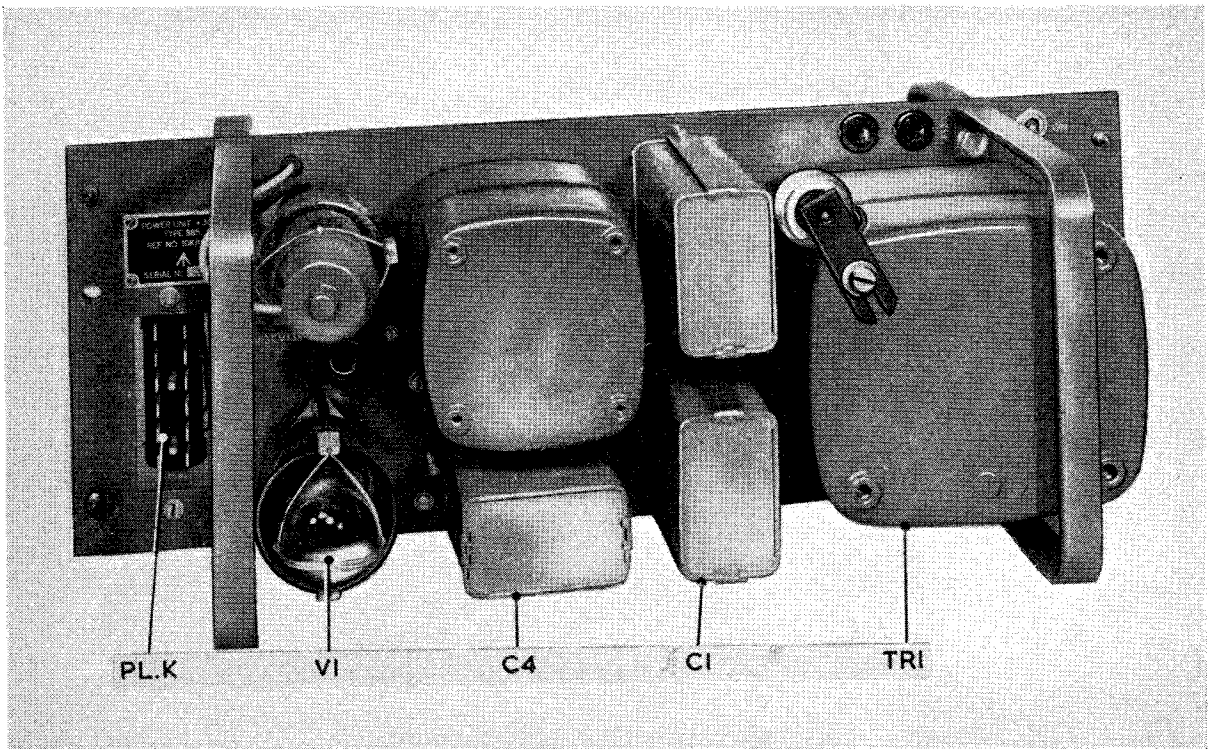

Fig. 4. Power unit (+300V.) Type 885

C1 and is smoothed by the filter circuit consisting of a choke L1 and capacitor C2. The output from this point, which is variable between 450 and 500 volts, is taken to pin 5 on PL.K. It is not stabilized and is not used in the present equipment.

output is performed by a regulating circuit using the valve V2, which is connected in the positive output line and passes the total current from the rectifier. The control-grid potential of this valve is regulated by the output from the valve V3. No separate standard reference voltage circuit is included, since this is available in the form of the

14. The stabilization of the positive 300-volts

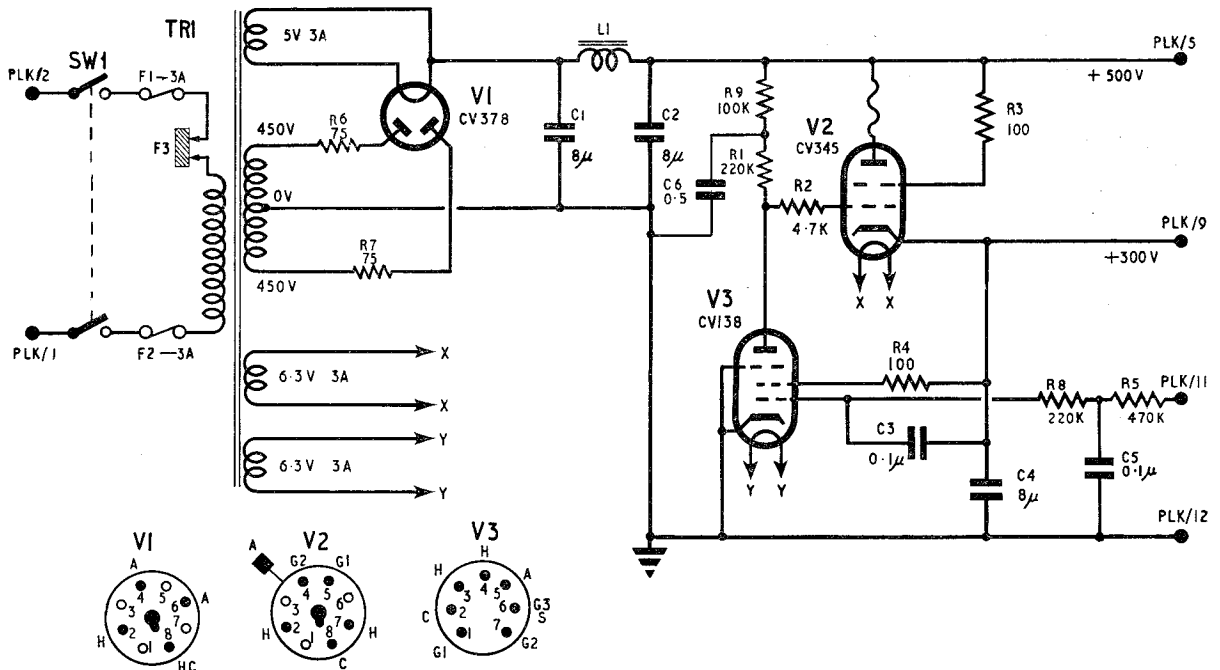

Fig. 5. Power unit (+300V) Type 885, circuit

RESTRICTED

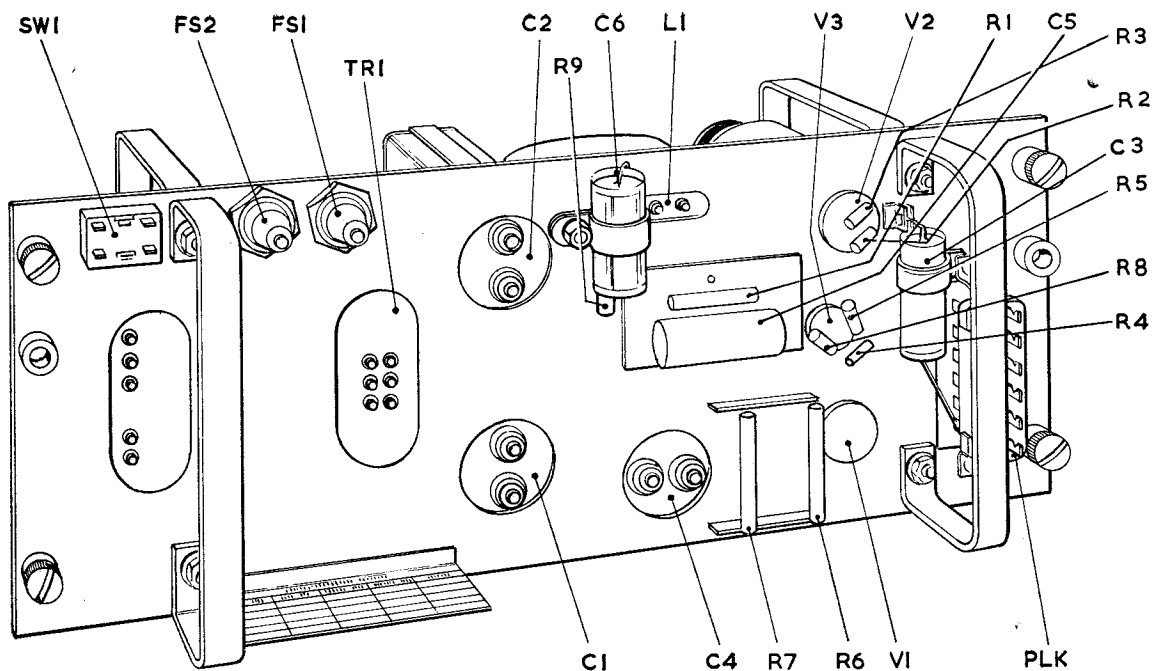

Fig. 6. Power unit (+300V.) Type 885, rear

stabilized negative 300-volt power supply, to which all three positive 300-volt units are connected by potentiometers (*para.* 10). Since each of these potentiometers is connected between a negative 300-volts and a positive 300-volts supply, with 200 kilohms each side, it follows that under normal load conditions when the output voltage developed across C4 is correct, the potential at the tapping on the potentiometer cannot be far removed from earth (even if mis-set to the extreme limit it will only be about 7 volts above or below earth).

15. Assume the control-grid of V3 to be at earth potential, and the output voltage across C4 to increase. The potential of the slider on the potentiometer will also increase, and with it the control-grid potential of V3. The anode

current of the valve will rise, and the anode potential will fall, accordingly; this fall of anode potential being also passed to the control-grid of V2 (via R2), causing a reduction of current through V2, and a corresponding decrease in output voltage across C4. Thus any tendency for the potential across C4 to rise or fall is compensated by the action of V3 upon the control-grid of V2.

16. A filter circuit, R8/C5 is connected into the input lead to the control grid of V3. This is to minimize the hum which is picked up by the long leads from the -300V power unit.

#### Construction

17. Front and rear views of the power unit are given in fig. 4 and 6. The heavy components are mounted upon the front of the panel.

## Chapter 7

### SWITCH UNIT TYPE 504

#### LIST OF ILLUSTRATIONS

	Fig.
EHT, MHT, +300V and -300V distribution ... ..	1
Switch unit Type 504, circuit ... ..	2
Switch unit Type 504 ... ..	3

1. The CRT in the indicating unit Type 33 requires an EHT supply at 15 kV, which is provided by the power unit (EHT) Type 882 described in the following chapter. This unit requires both a +300V and a -300V supply, the latter being provided by the power unit (-300V) Type 884. There are three power units (+300V) in the marker unit, of which No. 3 (the one at the bottom of the rack) supplies the EHT power unit. No. 2 supplies the video amplifier, the photo-electric unit, the indicating unit (centring and brightness control circuits) and also controls the switching of No. 3 as described later. No. 1 supplies the MHT power unit stabilizer circuits and the timebase unit; the switch unit Type 504 is not concerned in its operation.

2. The switch unit Type 504 is fitted to ensure that the generation of the EHT supply is not initiated until the other power supplies have been completed. To do this, it introduces, by means of a relay, a 15 second delay between the time of switching on No. 2 +300V unit and the completion of the input circuit to No. 3 +300V unit. A second relay in the switch unit completes the EHT circuit by connecting the cathode of the CRT to an earthy point.

3. The distribution of the EHT, MHT, +300V, and -300V supplies is shown in fig. 1. Assuming the 230-volt, 40-60 c/s supply is connected to the

termination panel at Jones plug L, the marker unit is switched on by closing the switches on all the power units so fitted, i.e. the MHT unit, the -300V unit, and the three +300V units. Valve heater supplies for the valves in units without self-contained heater transformers are provided by the MHT unit as soon as the latter is switched on.

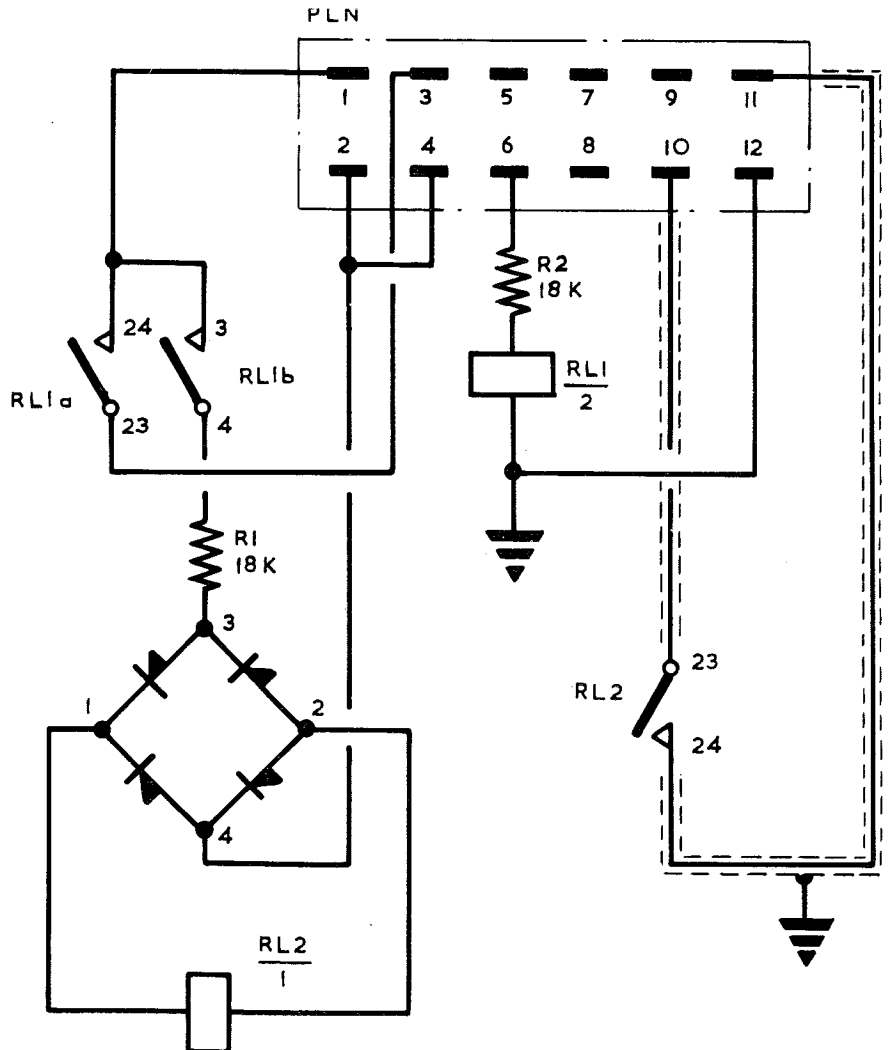

Fig. 2. Switch unit Type 504, circuit

4. No. 1 and No. 2 +300V power units receive their mains supply in the normal manner, but the supply to No. 3 is taken through the normally-open contact RL.1a in the switch unit. When No. 2 +300V unit has warmed up and is generating its output voltage, relay RL.1/2 in the switch unit becomes energized and the contacts RL.1a and RL.1b close. RL.1a completes the AC supply to No. 3 +300V unit, while RL.1b completes the supply from a bridge rectifier from which RL.2/1 is energized.

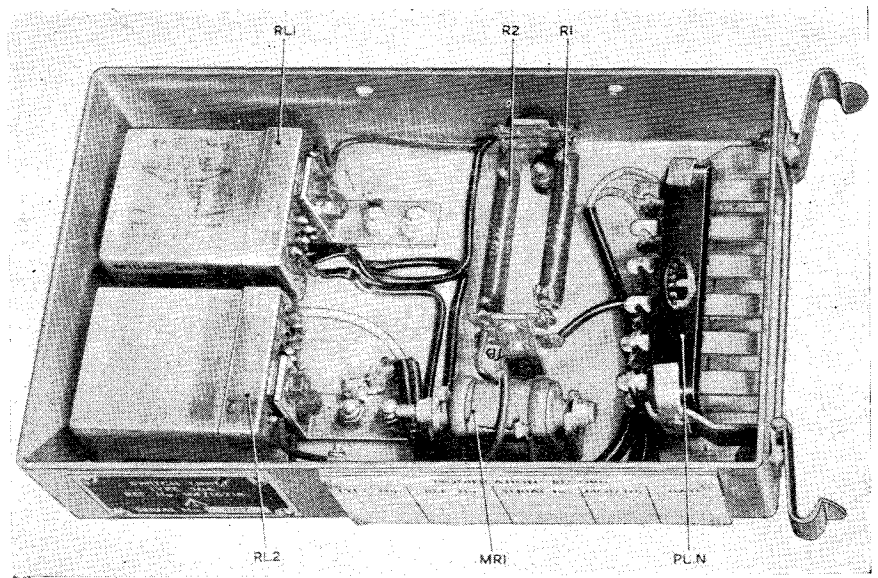

Fig. 3. Switch unit Type 504

5. The time delay between the closure of the mains switch on No. 2 +300V unit and the lighting of the pilot lamps on the cabinet should be not less than 15 seconds. Relay RL.2/1 will come on a little later and will complete the cathode circuit of the CRT to the tapping point on the brightness chain.

6. The complete circuit diagram of the switch unit Type 504 is given in fig. 2, and the general arrangement of the unit is shown in fig. 3. The unit is mounted on the left-hand side of the cabinet just behind and below the indicating unit.

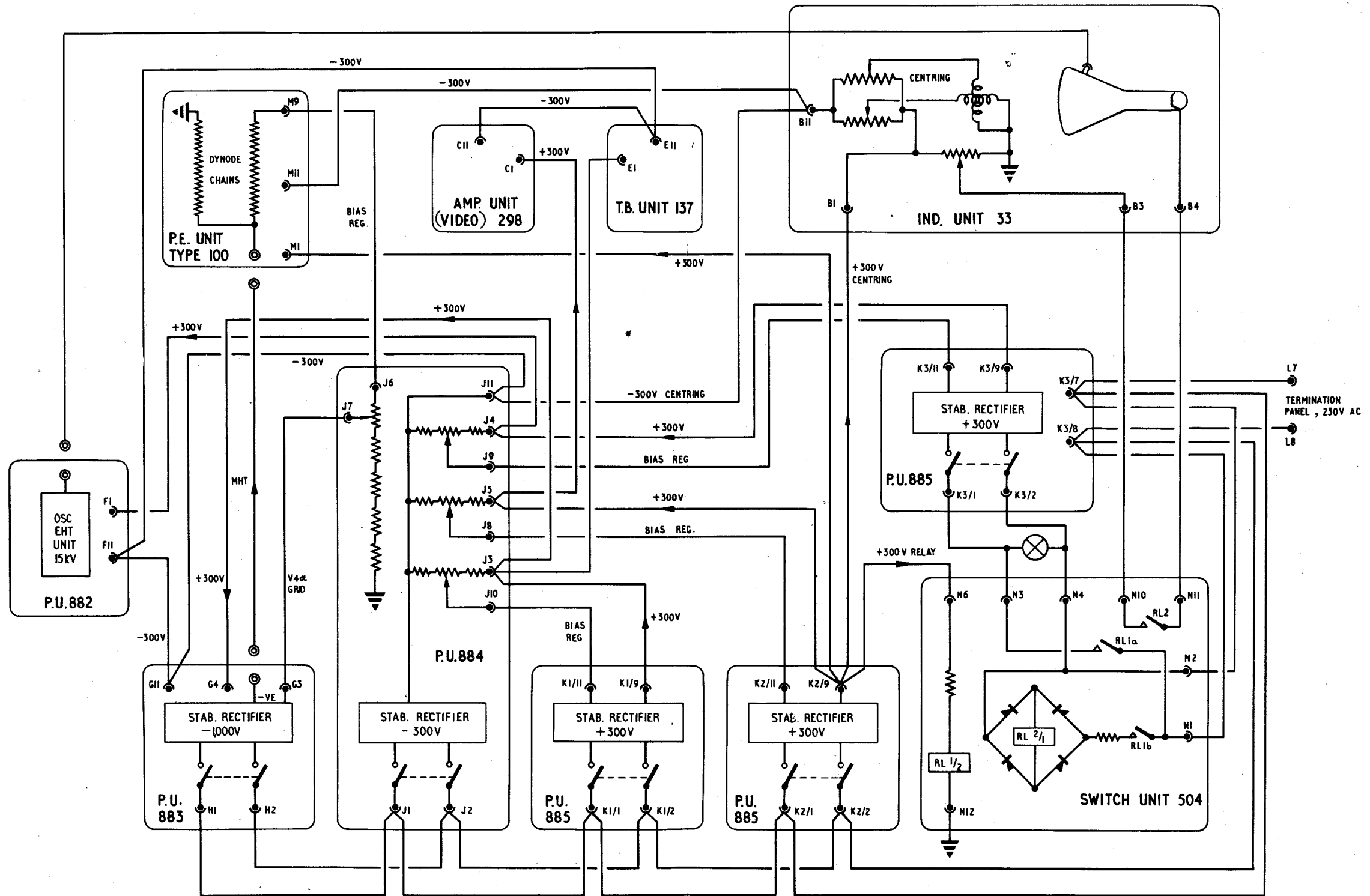

Fig. 1

EHT, MHT, +300V and -300V distribution

Fig. 1

R E S T R I C T E D

## Chapter 8

(This Chapter supersedes Chapter 8 issued with A.L.5)

### POWER UNITS (EHT) TYPE 882 AND (MHT) TYPE 883

#### LIST OF CONTENTS

	Para.		Para.
<b>Power unit (EHT) Type 882</b>		<b>Power unit (MHT) Type 883</b>	
Circuit description ... ..	1	Circuit description ... ..	19
Construction ... ..	14	Construction ... ..	27

#### LIST OF ILLUSTRATIONS

	Fig.		Fig.
Power unit (EHT) Type 882 ... ..	1	Power unit (MHT) Type 883 : circuit ...	4
Power unit (EHT) Type 882 (cover removed)	2	Power unit (MHT) Type 883 ... ..	5
Power unit (EHT) Type 882 : components		Power unit (MHT) Type 883 : rear view ...	6
on rear ... ..	3	Power unit (EHT) Type 882 : circuit ...	7

#### POWER UNIT (EHT) TYPE 882

##### Circuit description

1. The function of the power unit (EHT) Type 882 is to provide an EHT supply of approximately 15kV for the anode of the CRT in the indicating unit (CRT) Type 33. The EHT voltage is derived from the positive 300-volt DC supply fed to the unit from the power unit Type 885 by using a ringing circuit. The principle of the ringing circuit is described below.

2. When a strong magnetic field is built up in a solenoid by a current flowing through the winding, any abrupt interruption of the current will cause a rapid collapse of the magnetic flux, and consequently a very high peak voltage will be induced in the winding. The latter, together with the self-capacitance of the coil and associated stray capacitance, constitutes a tuned circuit, and provided the losses are low, this circuit will be shock-excited into oscillation at its natural frequency. Each interruption of the current will thus give rise to a damped wavetrain of very high initial amplitude and of low decrement, the latter being dependent mainly upon the losses in the core of the solenoid, if the resistance losses are kept low.

3. The circuit of the power unit is given in fig. 7. It consists of three principal parts, viz., the actual EHT oscillator and voltage-doubling rectifier comprised by the transformer TR1, valves V3, V4, V5, and associated components (b) a multivibrator circuit V1 with buffer valve V2, and (c) a stabilizing circuit using a diode-triode V6. The ringing coil is the winding L1 of the transformer TR1; the current through this coil is in effect switched on and off by the multivibrator V1, which controls the control-grid potential of V3.

4. The transformer TR1 has four windings wound on a Ferroxcube core (*see Note*). The main winding L1 is centre-tapped and functions as an auto-transformer, L2 is a winding which feeds the stabilizing circuit, and two small windings L3 and L4 provide the heater voltages for the diodes V4 and V5. Low-value resistors R25, R26 are connected in series with the two latter windings to reduce the voltage applied to the heaters to the correct value.

##### Note . . .

*Ferroxcube is a magnetic ceramic material having high permeability with comparatively low magnetizing current and low hysteresis loss. These qualities are essential since the oscillation is at high audio frequency, and must have a large initial amplitude with low decrement.*

5. The anode of V3 is connected to the approximate centre-tap (3) on L1, so that the winding between (3) and (4) is in the anode circuit; (4) is connected to the 300-volt HT rail. The control-grid of V3 is fed from the multivibrator V1 via the buffer valve V2. The multivibrator circuit is a conventional one, having the anode of V1a connected via C2 and C13 to the control-grid of V1b, and the output of V1b similarly fed via C1 to the control-grid of V1a. The frequency of this kind of multivibrator is inversely proportional to the sum of the time-constants R4 (C2+C13) and R1 C1; in the present case this is approximately 5 kc/s. The grid leaks R1 and R4 are returned to the HT rail, so giving a very steep-sided waveform.

6. The square-wave output from V1a is fed via C3 and the grid stopper R6 to the control-grid of the buffer stage V2. This stage is necessary to isolate the multivibrator from the switching valve V3,

RESTRICTED

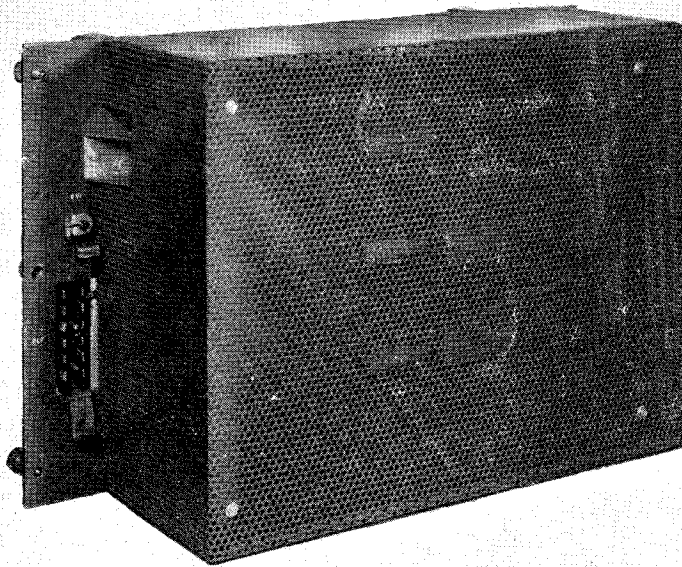

Fig. 1. Power unit (EHT) Type 882

since when V3 runs into grid current, the operation of the multivibrator would be affected. The arrangement of the anode circuit of V2 stage has been designed so that the square-wave shape of the multivibrator output is not distorted. The output from V2 is applied via C6 and R11 to the control-grid of V3 where it causes the anode current to be switched on and off very abruptly.

7. When V3 is conducting, its anode current (approximately 50 mA) flows through one half of L1. When the multivibrator causes V3 to cut off, the anode current ceases to flow in L1 almost instantaneously and a damped oscillation occurs

in L1. By the auto-transformer action between the two parts of L1, a high voltage appears across C7, the initial amplitude of the damped wavetrain being such as to make this voltage approximately 7.5 kV.

8. The rectifier circuit (which rectifies both positive and negative half-cycles of the oscillation) consists of V4, V5, and capacitors C7 and C8. The components C12, R24, are included in order that the total current drawn from the rectifier circuit may be measured with a microammeter connected to the test point X1. The rectifier operates as a cascade voltage doubler, the input being fed to the

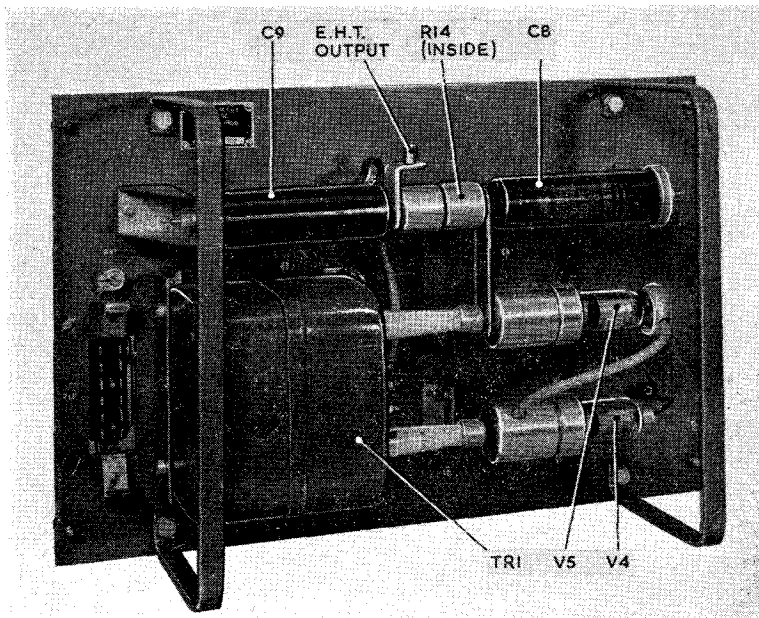

Fig. 2. Power unit (EHT) Type 882  
(cover removed)

RESTRICTED

junction of the anode of V5 and the cathode of V4 via C7. Were V5 not present C7 would charge to the peak voltage of 7.5 kV and the potential of the original junction point of the two valves would vary from zero to twice the peak voltage during one complete cycle of oscillation. ◀When V5 is connected C8 is also charged to a peak voltage of 15kV.

9. The output from the voltage doubler is therefore 15 kV which is fed to the CRT anode via a smoothing circuit and a special EHT connector. The smoothing circuit is formed by R14 and C9 and filters out any residual oscillatory ripple.

10. The voltage output of the unit is stabilized by the diode-triode V6. A sample of the oscillation, induced in L2, is rectified by the diode V6A.

The output of the rectifier circuit, across R15, is biased to a negative potential set by the potentiometer RV1. C11 forms the reservoir capacitor for the rectifier circuit.

11. Under normal conditions, the amplitude of oscillation across L2 approaches the bias potential and the grid of V6B is slightly negative. V6B operates as a D.C. amplifier, its output being D.C. coupled via divider R21, R22 to obtain the correct negative bias on the grid of V3.

12. If the amplitude of the oscillation across L2 rises, the grid of V6B will rise, causing V6B anode to fall. Thus V3 grid will fall and the amplitude of the pulses at V3 anode will decrease, reducing the amplitude of the oscillations in L1.

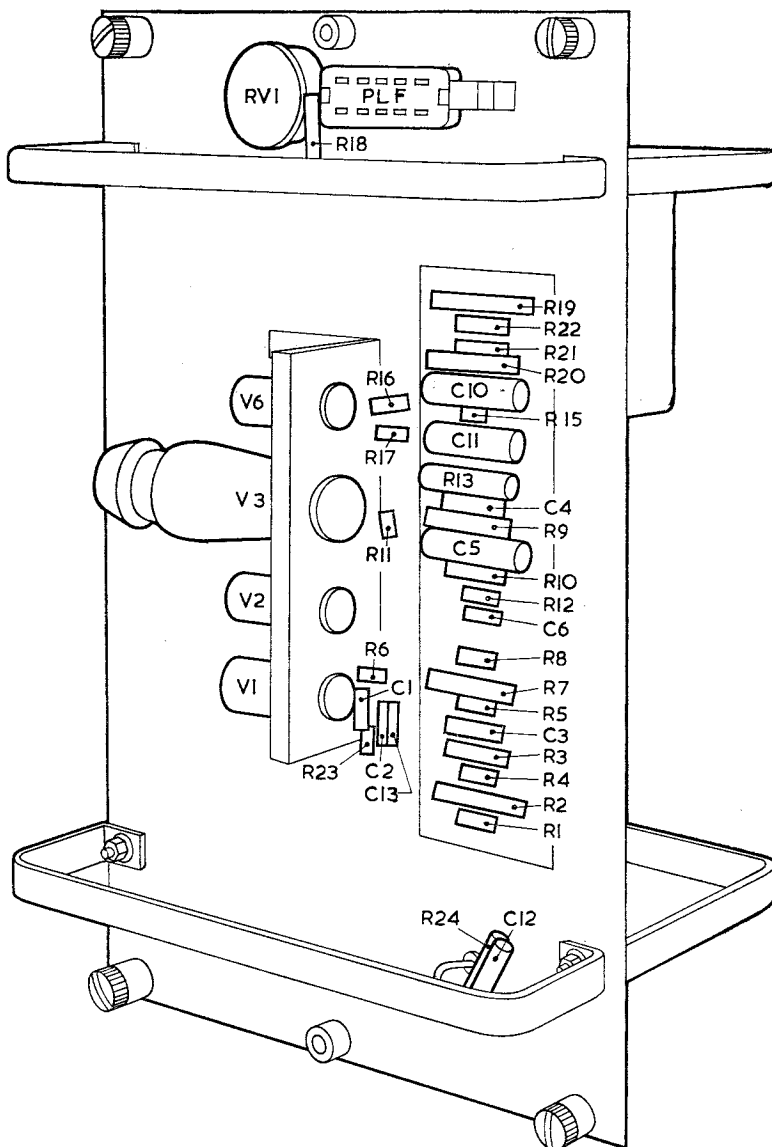

Fig. 3. Power unit (EHT) Type 882 : components on rear

RESTRICTED

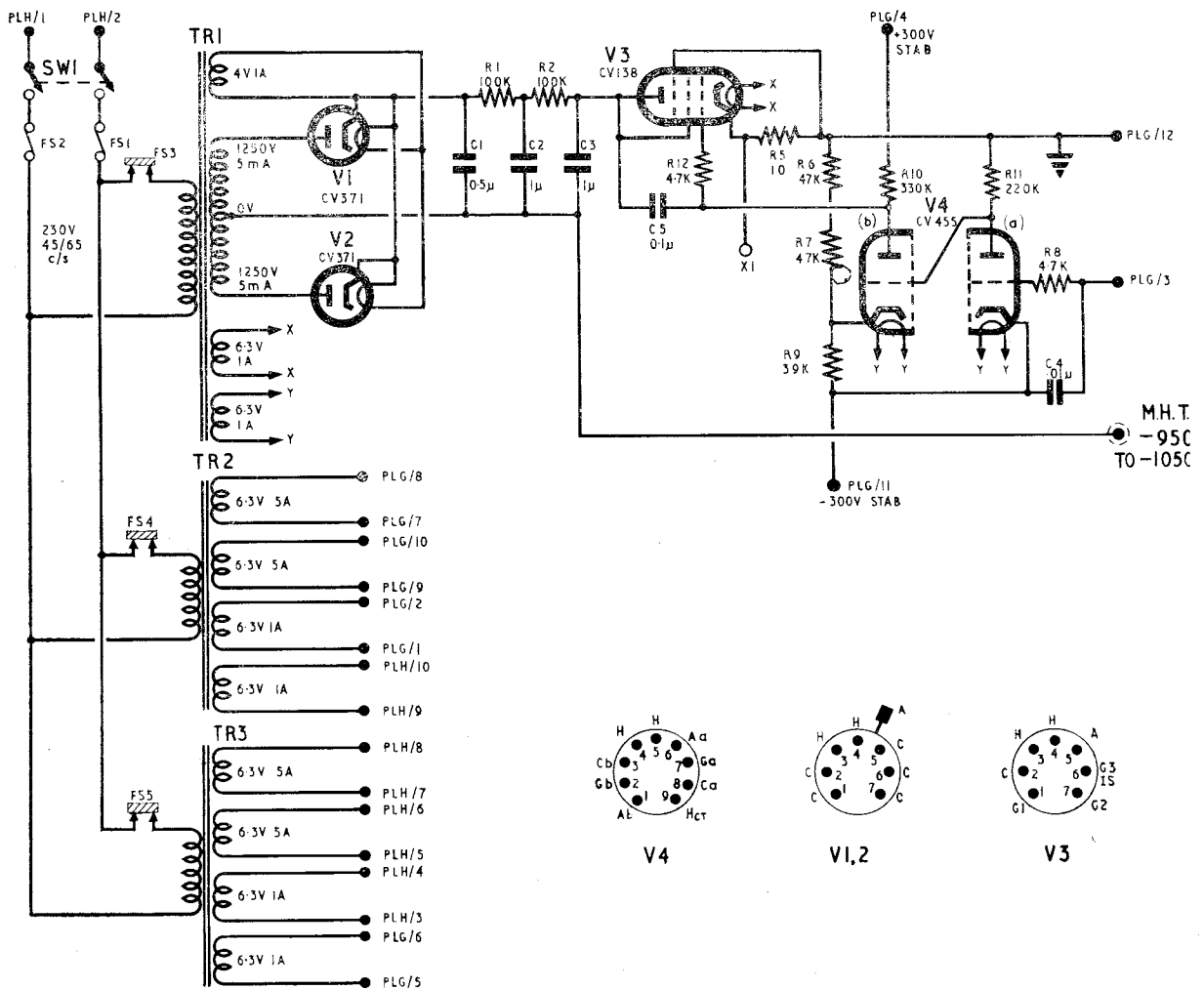

Fig. 4. Power unit (MHT) Type 883: circuit

13. The setting of RV1 determines the amplitude of oscillation necessary to produce the correct bias potential for V6B and thus controls the voltage output of the unit. ▶

#### Construction

14. The general appearance of the unit is shown in fig. 1; the perforated metal cover should always be in position under operating conditions. Fig. 2 shows the front of the unit with this cover removed. All the EHT components are mounted on this side of the chassis. Great care has been taken in the manufacture to avoid sharp edges or corners on any of the components; this precaution is necessary to avoid corona effects which would otherwise occur owing to the very high voltage.

15. The transformer TR1, feeding the rectifier diodes V4 and V5, is on the left-hand side. The connections to the diodes are made from the high voltage terminals of TR1 via connectors which completely enclose the bases of the valves. The top-cap anode of V4 fits into a clip mounted on a triangular piece of insulating material, which is itself mounted on an angle bracket bolted to the chassis. To remove V4, the insulating piece must

be unscrewed, permitting the top-cap clip to be disconnected from the valve. The anode connection to V5 is made by a lead terminated in a clip mounted in, but insulated from, a metal screen cap.

16. The reservoir condenser C8 and smoothing capacitance C9 are mounted horizontally in brackets along the top of the unit. They are connected electrically by the two connectors showing the right-hand connector having the resistor R14 mounted inside it. The output connection from V5 cathode to the junction of C8 and R14 is made by a heavy metal strip which is easily recognized in fig. 2.

17. The components of the remainder of the power unit, viz., the multivibrator V1, buffer stage V2, switching valve V3, and stabilizer valve V6, are mounted on the rear of the chassis the locations of the components being shown in fig. 3. The valves V1, V2, V3, V6, are mounted on a platform bolted to the middle of the chassis; immediately below this platform is a large group board which carries most of the resistors and capacitors associated with these valves.

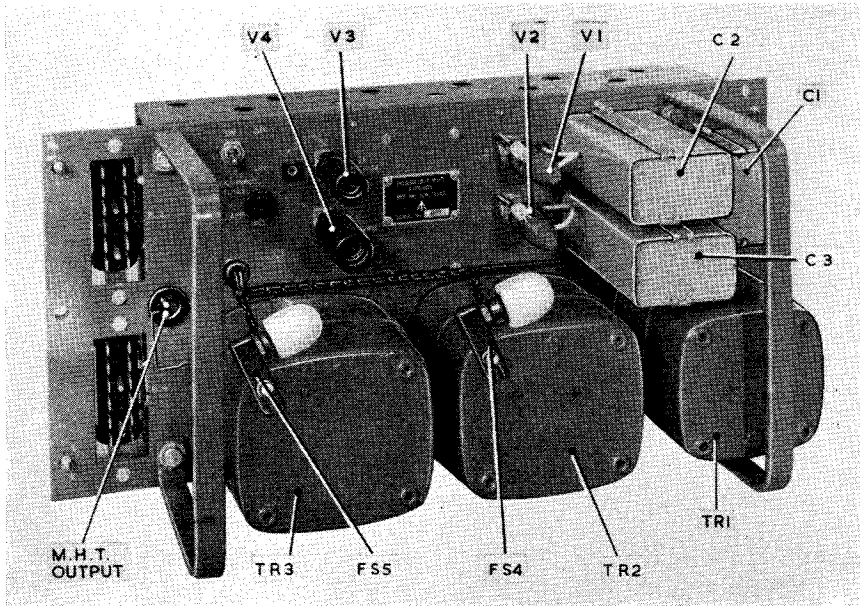

Fig. 5. Power unit (MHT) Type 883

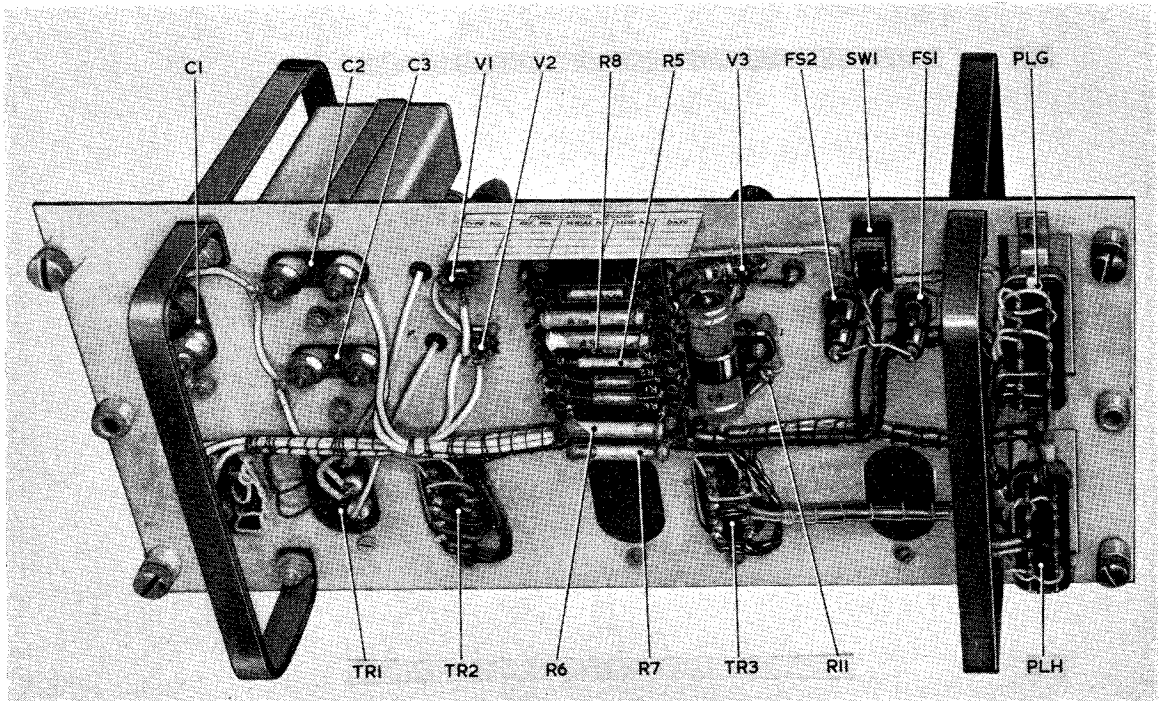

Fig. 6. Power unit (MHT) Type 883 : rear view

**RESTRICTED**

18. The potentiometer RV1 mounted on the right-hand side of the chassis gives control of the output voltage without removal of the perforated metal cover. Below it is the Jones plug PL.F which carries the input power supplies from the power units Type 884 and 885.

### POWER UNIT (MHT) TYPE 883

#### Circuit description

19. The photo-multipliers in the photo-electric unit Type 100 derive their various electrode potentials from potential divider circuits across which is applied  $-1,000$  volts; this voltage, which is stabilized, is supplied by the power unit (MHT) Type 883. The cathode of each photo-multiplier is at the full negative  $1,000$  volts, and the first six dynodes are fed from the divider network. The final three dynodes, which draw the greatest currents, are fed from the  $-300\text{V}$  power pack in order to reduce the current drain on the MHT power unit.

20. The circuit diagram of the MHT power unit is given in fig. 4. The mains voltage is connected via the switch SW1 and fuses FS1, FS2, to the primaries of three transformers TR1, TR2, and TR3. TR2 and TR3 are purely heater transformers providing  $6.3$  volts at various currents for the heaters of the valves in other units of the equipment via plugs PL.H and PL.G.

21. Transformer TR1 has four secondary windings, three being heater windings for V1 and V2, V3, V4 respectively. A centre-tapped HT winding ( $1,250-0-1,250$ ) feeds the anodes of the two valves V1, V2, comprising the full-wave rectifier circuit. The output from this circuit, developed across the reservoir condenser C1, is approximately  $950$  to  $1,050$  volts at  $5$  mA. Since the current is low, a resistor-capacitor network R1, R2, C2, C3 is satisfactory as a ripple filter. The output line from the cathodes of V1 and V2 is connected via a series regulator valve V3, the cathode of which is at practically earth potential. The negative output voltage is taken from the centre tap of the HT winding on TR1.

#### Note . . .

*A diagram giving the external connections about to be described is given in the previous chapter.*

22. The stabilizing device operates through the load circuit external to the unit, consisting of two potential divider chains in the photo-electric unit Type 100, viz., R1 to R7 and R23 to R28 respectively. The first chain is earthed, but the second is connected via R29 to a control circuit in the power unit ( $-300\text{V}$ ) Type 884. The control circuit consists of a chain of fixed resistors and a potentiometer RV4. The slider of this potentiometer

is brought back via PL.J(7) and PL.G(3) to the control-grid of V4a, via R8. The cathode of V4a is held at  $-300$  volts by a connection to the power unit Type 884, via PL.G(11).

23. The anode of V4b is connected to the control-grid of V3 and also to the stabilized  $+300\text{V}$  supply line via the high value resistor R10. Also, since the control-grid and cathode of V4b must be at the same potential under normal conditions, the anode of V4a is connected to the control-grid of V4b. The cathode of this valve is connected to a point on the potential divider R6, R7, R9, equal to the anode voltage of V4a; that is, a voltage equal to the supply voltage minus the voltage drop across R11.

24. Under normal conditions, when the output from the unit is  $-1,000$  volts, the slider of RV4 will be at approximately  $-300$  volts, and so therefore is the control-grid of V4a. Cathode and control-grid of V4a are thus at the same potential. Similarly, control-grid and cathode of V4b are at the same potential as already described. Owing to the voltage drop in R10, the anode of V4b is approximately at earth potential.

25. If the output current rises, the voltage drop across RV4 increases (in the negative sense) and the control-grid potential of V4a will vary accordingly. Thus the potential at V4a anode and V4b control-grid will now rise and, owing to the valve gain, will cause a fall in potential at the anode of V4b, greater than the increase at the control-grid. This fall in anode potential is applied to the control grid of the regulator valve V3, so reducing the current through it. Thus the output voltage will be reduced until the voltage at the slider of RV4 is restored to its normal value,  $-300$  volts.

26. The stabilizing action of the circuit for a rise of output current will be the converse of the above, the action being such that the control-grid of V4a always reaches an equilibrium potential equal to that of its cathode, i.e.  $-300$  volts. Movement of the slider of RV4, therefore, gives direct control of the output voltage.

#### Construction

27. The main components shown in the front view of the power unit (fig. 5) are the three mains transformers TR1, TR2, TR3, the mains switch SW1, and the associated fuses FS1, FS2. The high voltage socket mounted on the left-hand side is the MHT output. The valves V1 and V2 are the two diodes forming the full-wave rectifier circuit and C1, C2, C3 are the capacitors of the ripple filter. The screened valves V3 and V4 near the name plate are the series regulator and double-triode valves.

28. The rear view (fig. 6) is fully annotated, all the components associated with the series regulator circuit being carried on one small group board.

**RESTRICTED**

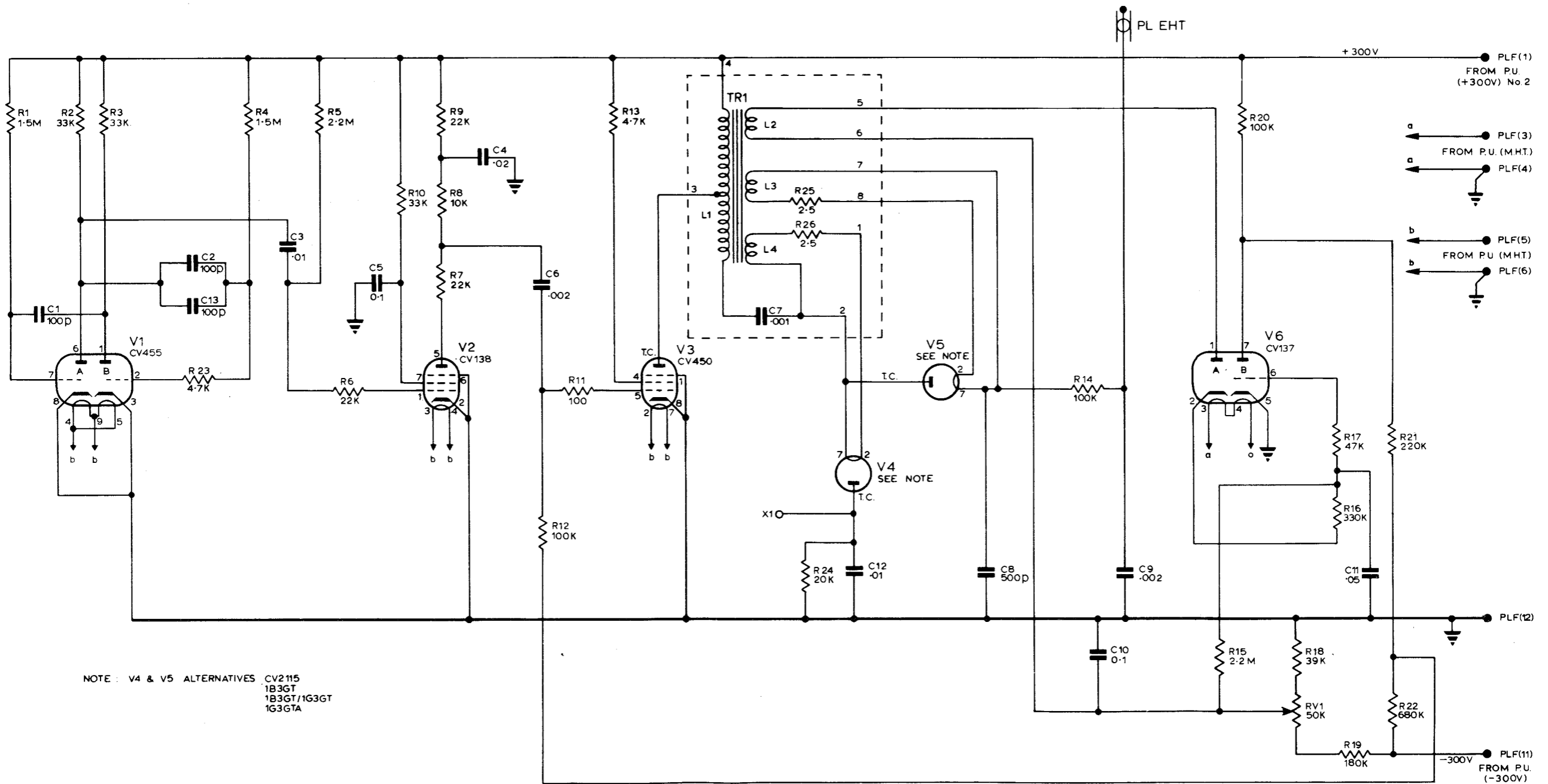

Fig.7

May 80 (Amdt. 20)

Power unit (EHT) Type 882 circuit.

RESTRICTED

Fig.7.

Chap.8  
Page 7/8