

As you are now the owner of this document which should have come to you for free, please consider making a donation of £1 or more for the upkeep of the (Radar) website which holds this document. I give my time for free, but it costs me money to bring this document to you. You can donate here <https://blunham.com/Radar>

Do not upload this copyright pdf document to any other website. Breaching copyright may result in a criminal conviction and large payment for Royalties.

This pdf document was generated by me Colin Hinson from a Crown copyright document held at R.A.F. Henlow Signals Museum. It is presented here (for free) under the Open Government Licence (O.G.L.) and this pdf version of the document is my copyright (along with the Crown Copyright) in much the same way as a photograph would be.

The document should have been downloaded from my website <https://blunham.com/Radar>, or any mirror site named on that site. If you downloaded it from elsewhere, please let me know (particularly if you were charged for it). You can contact me via my Genuki email page: <https://www.genuki.org.uk/big/eng/YKS/various?recipient=colin>

You may not copy the file for onward transmission of the data nor attempt to make monetary gain by the use of these files. If you want someone else to have a copy of the file, point them at the website (<https://blunham.com/Radar>). Please do not point them at the file itself as it may move or the site may be updated.

It should be noted that most of the pages are identifiable as having been processed by me.

I put a lot of time into producing these files which is why you are met with this page when you open the file.

In order to generate this file, I need to scan the pages, split the double pages and remove any edge marks such as punch holes, clean up the pages, set the relevant pages to be all the same size and alignment. I then run Omnipage (OCR) to generate the searchable text and then generate the pdf file.

Hopefully after all that, I end up with a presentable file. If you find missing pages, pages in the wrong order, anything else wrong with the file or simply want to make a comment, please drop me a line (see above).

If you find the file(s) of use to you, you might like to make a donation for the upkeep of the website – see <https://blunham.com/Radar> for a link to do so.

Colin Hinson

In the village of Blunham, Bedfordshire, UK.

© Crown Copyright 1995

Published by and obtainable from:
Ministry of Defence
Directorate of Standardization
Kentigern House
65 Brown Street
GLASGOW G2 8EX

Tel No: 0141-224 2531/2532

Fax No: 0141-224-2503

This Standard may be fully reproduced except for sale purposes. The following conditions must be observed:

- 1 The Royal Coat of Arms and the publishing imprint are to be omitted.
- 2 The following statement is to be inserted on the cover:
'Crown Copyright. Reprinted by (name of organization) with the permission of Her Majesty's Stationery Office.'

Requests for commercial reproduction should be addressed to MOD Stan 1, Kentigern House, 65 Brown Street, Glasgow G2 8EX

The following Defence Standard file reference relates to the work on this Standard - D/D Stan/318/27/08.

Contract Requirements

When Defence Standards are incorporated into contracts users are responsible for their correct application and for complying with contract requirements.

Revision of Defence Standards

Defence Standards are revised when necessary by the issue either of amendments or of revised editions. It is important that users of Defence Standards should ascertain that they are in possession of the latest amendments or editions. Information on all Defence Standards is contained in Def Stan 00-00 (Part 3) Section 4, Index of Standards for Defence Procurement - Index of Defence Standards and Specifications published annually and supplemented periodically by Standards in Defence News. Any person who, when making use of a Defence Standard encounters an inaccuracy or ambiguity is requested to notify the Directorate of Standardization without delay in order that the matter may be investigated and appropriate action taken.

OBSOLESCE

Ministry of Defence

OBSOLESCE

Defence Standard

59-35 (PART 0) / Issue 3

31 JANUARY 1990

CONNECTORS ELECTRICAL

PART 0: GUIDE TO CONNECTORS

ELECTRICAL, DIRECT CURRENT,

LOW FREQUENCY AND RADIO

FREQUENCY,

AND THEIR APPLICATION.

∕ OBSOLESCE ∕

**THIS DEFENCE STANDARD WILL NOT BE UPDATED AND IS
NOT TO BE USED FOR THE PURCHASE OF NEW EQUIPMENT**

<p>This Defence Standard 59-35 (Part 0)/Issue 3 supersedes Defence Standard 59-35 (Part 0)/Issue 2 dated August 1987</p>

AMENDMENTS ISSUED SINCE PUBLICATION

AMD NO	DATE OF ISSUE	TEXT AFFECTED	SIGNATURE & DATE

Revision Note

This Standard has been revised to include sections covering Connectors electrical, Rectangular, Printed Board, and Radio Frequency as well as Circular.

Historical Record

Def Stan 59-35 Part 0 Issue 1 - Issued for Connector Electrical Circular only.

Def Stan 59-35 Part 0 Issue 2 - Re-issued to update information.

SECTION ONE:

GENERAL.

SECTION TWO:

CONNECTORS ELECTRICAL

CIRCULAR.

SECTION THREE:

CONNECTORS ELECTRICAL

RECTANGULAR.

SECTION FOUR:

CONNECTORS ELECTRICAL

TWO-PART PRINTED BOARDS.

SECTION FIVE:

CONNECTORS ELECTRICAL

RADIO FREQUENCY.

CONNECTORS ELECTRICAL

PART 0: GUIDE TO CONNECTORS ELECTRICAL,
AND THEIR APPLICATION

PREFACE

This Part of this Defence Standard
supersedes Def Stan 59-35 (Part 0) Issue 2,
dated 27 August 1987

i The purpose of this Part of the Defence Standard is to provide users with advice on the characteristics of connectors electrical, for Ministry of Defence use. It may be used by other Government Departments and Industry.

ii The information contained herein relates to definitions, abridged parameters and application through a series of Defence Standard Guide Sheets for connectors electrical. There are 4 types:

circular
rectangular
printed board
radio frequency

iii This Standard should be read and used in conjunction with:

(a) BS 9520 'Specification for electrical connectors of assessed quality for dc and low frequency applications' and Def Stan 59-35 (Part 3 or Part 5) for connectors electrical, circular, rectangular and printed board.

(b) BS 9210 'Radio frequency connectors of assessed quality, generic data and method of test' and Def Stan 59-35 (Part 2 or Part 4) for connectors electrical (rf).

Generic and Rule Standards Applicable

SECTION		GENERIC DOCUMENT APPLICABLE	RULES DOCUMENT APPLICABLE
TWO	Circular	BS 9520 BS 9521 BSG 202	BS 9522 CECC 75-200/201
THREE	Rectangular	BS 9520 BS 9521	BS 9523 BS 9524
FOUR	Printed Board	BS 9520 BS 9521	BS 9525 CECC 75-100
FIVE	Radio Frequency	BS 9210	CECC 22-100

CONNECTORS ELECTRICAL

PART 0: GUIDE TO CONNECTORS ELECTRICAL,
AND THEIR APPLICATION

PREFACE

This Part of this Defence Standard
supersedes Def Stan 59-35 (Part 0) Issue 2,
dated 27 August 1987

i The purpose of this Part of the Defence Standard is to provide users with advice on the characteristics of connectors electrical, for Ministry of Defence use. It may be used by other Government Departments and Industry.

ii The information contained herein relates to definitions, abridged parameters and application through a series of Defence Standard Guide Sheets for connectors electrical. There are 4 types:

- circular
- rectangular
- printed board
- radio frequency

iii This Standard should be read and used in conjunction with:

(a) BS 9520 'Specification for electrical connectors of assessed quality for dc and low frequency applications' and Def Stan 59-35 (Part 3 or Part 5) for connectors electrical, circular, rectangular and printed board.

(b) BS 9210 'Radio frequency connectors of assessed quality, generic data and method of test' and Def Stan 59-35 (Part 2 or Part 4) for connectors electrical (rf).

Generic and Rule Standards Applicable

SECTION		GENERIC DOCUMENT APPLICABLE	RULES DOCUMENT APPLICABLE
TWO	Circular	BS 9520 BS 9521 BSG 202	BS 9522 CECC 75-200/201
THREE	Rectangular	BS 9520 BS 9521	BS 9523 BS 9524
FOUR	Printed Board	BS 9520 BS 9521	BS 9525 CECC 75-100
FIVE	Radio Frequency	BS 9210	CECC 22-100

<u>List of Contents</u>	<u>Page</u>
Preface	1
List of Contents	3
 <u>Section One. General</u>	
0 Introduction	1-1
1 Scope	1-1
2 Related Documents	1-1
3 Definitions	1-2
4 Terminology	1-5
5 Selection of Connectors	1-5
6 Guidance on the Selection Criteria for Connector Filtered Contacts	
7 Selection, Cross Reference Tables and Guide Sheets	1-6
8 Qualification Approval	1-6
 <u>Section Two. Connectors Electrical, Circular</u>	
1 Scope	2-1
2 Types of Coupling	2-1
3 Connector Housing	2-1
4 Contacts	2-2
Table A-1 Selection Chart for Connectors Electrical, Circular	2-3
Table A-2 Cross Reference of Contacts/Contact Arrangements	2-5
Annex A Def Stan Guide Sheets For Connectors Electrical Circular	A-1
 <u>Section Three. Connectors Electrical, Rectangular</u>	
1 Scope	3-1
2 Types of Latching/Locking	3-1
3 Connector Body	3-1
4 Contacts	3-1
Table B-1 Selection Chart For Connectors Electrical, Rectangular	3-2
Table B-2 Cross Reference of Contacts/Contact Arrangements	3-3
Annex B Def Stan Guide Sheets for Connectors Electrical, Rectangular	B-1

DEF STAN 59-35 (PART 0)/3
CONTENTS (CONTD)

	<u>Page</u>
<u>Section Four. Connectors Electrical, Two-Part Printed Board</u>	
1 Scope	4-1
2 Types of Latching/Locking	4-1
3 Connector Body	4-1
4 Contacts	4-1
Table C-1 Selection Chart For Connectors Electrical, Two-Part Printed Board	4-2
Table C-2 Cross Reference of Contacts/Contact Arrangements	4-3
Annex C Def Stan Guide Sheets For Connectors Electrical, Two-Part Printed Board	C-1
<u>Section Five. Connectors Electrical, Radio Frequency</u>	
1 Scope	5-1
2 Definitions	5-1
3 Connector Style Reference Numbers	5-1
4 Assessment Levels	5-1
Table D-1 Selection Chart For Connectors Radio Frequency	5-2
Table D-2 Cross Reference of Cable Type To Connector Series	5-3
Annex D Def Stan Guide Sheets for Connectors Electrical Radio Frequency	D-1

CONNECTORS ELECTRICAL

PART 0: GUIDE TO CONNECTORS ELECTRICAL, DIRECT CURRENT LOW FREQUENCY AND RADIO FREQUENCY, AND THEIR APPLICATIONS

Section One. General

0 Introduction

1 Scope

This Standard gives guidance to designers, Service users, and others, concerned with supplying military equipment in the selection of a suitable connector electrical, for their particular requirement.

1.1 The choice will be affected by functional use as required by the Services for particular application, environmental conditions, and other factors which are considered in general terms in this guide, consideration should also be given to NOTE on page 2 of this Standard.

2 Related Documents

2.1 Reference is made in this Part of the Standard to:

IEC Publication 50 (581)	International Electrotechnical Vocabulary
Q STAG 228	Armies Standardization Program: Connectors for Multi-Pair Field Telephone Cables
CECC 22 000	Generic Specification: Radio Frequency Connectors
CECC 00 200	CECC Qualified Products List
BS CECC 75-100	Harmonised System of Quality Assessment for Electronic Components: Sectional Specification: Two-Part and Edge Socket Connectors for Printed Board Application
BS CECC 75-200	Harmonised System of Quality Assessment for Electronic Components: Sectional Specification: Circular Connectors
BS 9000	Specification for General Requirements for Electronic Components of Assessed Quality
BS 9210	Radio Frequency Connectors of Assessed Quality; Generic Data and Methods of Test
BS 9520	Specification for Electrical Connectors of Assessed Quality dc and Low Frequency Applications
PD 9002	BS 9000 and BS CECC Qualified Products List
Def Stan 00-9	General Requirements for Qualification Approval and Quality Assurance of Electronic Components for Ministry of Defence Use
Def Stan 59-20	Index to NATO Electronic Parts Recommendations (NEPRs) and NATO Electronic Technical Recommendations (NETRs)
Def Stan 05-37	The Policy for the Procurement of Electronic Components
Def Stan 59-35	Plugs and Sockets, Electrical (dc and Low Frequency)
SERIES OF PARTS	Applications
Def Stan 59-36	Electrical and Electronic Components for Defence Purposes: Procedure for the Selection and Specification of Electrical and Electronic Components for Use in Defence Equipment

DEF STAN 59-35 (PART 0)/3
SECTION 1 (CONTD)

2.1 (Contd)

INTERIM Part 1 Plugs and Sockets, Electrical Pattern 602:
Def Stan 59-56 Standard and Maintenance Ranges
Def Stan 59-59 Electrical/Electronic Components for Defence Use - Services
Qualified Products List including Components of Assessed
Quality

2.2 British Standards, CECC and IEC Standards are obtainable from:

British Standards Institution
Sales Office
Linford Wood
MILTON KEYNES MK14 6LE

2.3 Defence Standards and QSTAG 228 are obtainable from:

Directorate of Standardization (Stan 1)
Kentigern House
65 Brown Street
GLASGOW G2 8EX

2.4 Reference in this Part of the Standard to any related document means, in any tender or contract, the edition current at the date of such tender or contract unless a specific edition is indicated.

3 Definitions

3.1 For the purposes of this Defence Standard the following definitions have been taken from IEC publication 50 (581); other definitions have been taken from BS 9210 and BS 9520. Where variance of any definition occurs the IEC definition will take precedence.

3.1.1 Definitions specific to radio frequency connectors only are contained in Section Five.

3.1.2 Barrier Seal. A seal preventing the passage of moisture or gases between the dielectric insert, the contacts and the body shell of a connector or adaptor.

3.2 Connector. A component which terminates conductors for the purpose of providing connection and disconnection to a suitable mating component.

3.2.2 Board mounted connector. A connector suitable for being permanently attached to a printed board.

3.2.3 Butting connector. A connector in which connection is achieved between non-penetrating contacts and maintained by axial pressure.

3.2.4 Circular connector. A connector which is basically cylindrical and has a mating face with a basically circular periphery.

3.2.5 Connector body. The basic part of a connector, eg the housing (shell) and insert less contacts, to which accessories may be attached.

3.2.6 Connector housing. The part of a connector into which the insert and contacts are assembled.

3.2.7 Connector insert. An insulating element designed to support and position contacts in a connector housing.

(a) The insert may provide environmental sealing between individual contacts and between all contacts and the connector housing.

(b) May provide a pressure differential barrier between the two ends of a connector.

(c) The angular position of an insert within a circular connector may be set to any one of a number of positions during manufacture.

3.2.8 Connector orientation. A system providing alternative polarization to prevent cross-mating of similar components when, for instance, used on the same equipment.

(a) Identification of the orientation is from a specified datum point on the interface to a specified datum on the shell, such as a major key or keyway.

(b) Key. A projection which engages with a keyway to guide a component during mating.

(c) Keyway. A slot or groove in which a key engages.

3.2.9 Connector polarization. The provision of features to ensure the correct alignment of connectors during mating and to prevent accidental mating of similar connectors.

3.2.10 Contact. The conductive element in a connector that mates with a corresponding element in another connector to transfer electrical energy.

3.2.11 Contact arrangement. The combination of the spacing, positioning and number of contacts locations in a connector.

3.2.12 Contact extraction force. The axial force required to extract a removable contact from a component.

3.2.13 Contact retention force. The axial load in either direction that a contact can withstand without being displaced from its intended position within an insert.

3.2.14 Contact force. The normal force (90°) which exists between engaged contact surfaces.

3.2.15 The engaging or separating force contacts. The force needed fully to engage or separate a mating pair of contacts.

DEF STAN 59-35 (PART 0)/3
SECTION 1 (CONTD)

3.2.16 Contact size. The designation used to differentiate one contact from another. It may be denoted by one of the following systems:

(a) Current rating: the related current carrying capacity is used to denote the size of the contact.

(b) Numbering: assigned numbers used to denote the size of the contact and its related conductor accommodation.

3.2.17 Environment resistant connector. A connector provided with means for protection against moisture, temperature or contaminants.

3.2.18 Female contact. A contact having an engagement end that will accept entry of a male contact.

3.2.19 Male contact. A contact having an engagement end that makes contact by insertion into the female contact.

3.2.20 Crimp. The mechanical formation of a contact barrel around a conductor to make an electrical connection.

3.2.21 Crimping. A method of permanently attaching a termination to a conductor by pressure deformation or by reshaping the barrel around the conductor to establish good electrical and mechanical connection.

3.2.22 Fixed connector. A connector for attachment to a rigid surface.

3.2.23 Free connector. A connector for attachment to the free end of a wire or cable.

3.2.24 Free connector coupler. A connector that mates with a free connector in a cable to cable application.

3.2.25 Hermaphroditic connector. A connector that mates with an identical connector.

3.2.26 Hermetic connector. A connector having an hermetic seal.

3.2.27 Hermetic seal. A seal is hermetic when the specified rate of leakage is several orders smaller than that of a barrier seal.

3.2.28 Panel seal. A seal provided between a fixed connector/adaptor and a panel to prevent the passage of moisture or gases through the gap between the connector/adaptor and the named mounting hole(s).

3.2.29 Printed board connector. A connector specifically designed to facilitate connections to printed boards.

3.2.30 Rack and Panel connector. One of two mating fixed connectors intended to provide a connection between a unit and its mounting rack. It is usually provided with an alignment device to ensure correct mating. It normally has no coupling device and is mated by movement between the unit and the rack.

3.2.31 Rectangular connector. A connector which is basically rectangular and has a basically rectangular mating face.

3.2.32 Scoop proof connector. A connector incorporating features preventing its contacts from being touched by the front of the mating connector.

3.2.33 Solderless wrap joint. A joint achieved solely by wrapping a wire conductor around a post having sharp corners.

3.2.34 Wire wrap. See solderless wrap joint.

4 Terminology

4.1 For the purposes of this Defence Standard the following terminology is applicable and is set out in order of precedence.

4.1.1 Type. A basic shape, eg circular, rectangular, printed board and radio frequency.

4.1.2 Pattern. A design covered by an individual detail specification.

4.1.3 Range. The connector housing sizes and contact arrangements within a pattern.

4.1.4 Style. Configurations within a range, eg coupler, fixed, free.

4.1.5 Variant. An individual connector within a style, having a feature or features different from the standard connector.

4.1.6 Interchangeable. A component is interchangeable when it meets the original performance specifications and is intermountable. In the case of connectors, interchangeability applies only to connector mated sets, since individual connectors are not necessarily intermateable.

4.1.7 Intermateable. Two connectors are intermateable when they are capable of being connected electrically and mechanically but without regard to their performance and intermountability.

4.1.8 Intermountable. Two components are intermountable when their mechanical mounting parameters are identical without regard to intermateability or interchangeability.

5 Selection of Connectors

5.1 The selection by users, of a connector for a particular application will involve the consideration of numerous parameters. It is not possible to list every attribute or parameter so as a general guide some of these have been set out below.

DEF STAN 59-35 (PART 0)/3
SECTION 1 (CONTD)

5.1.1 General (LF and RF)

- (a) How many circuits are involved (determines minimum sizes).
- (b) Application (power, signal current, frequency etc).
- (c) Environmental (exposed or protected).
- (d) Maximum current and voltage, frequency (determines contact size, and spacing also connector housing size). Electrical connectors only.
- (e) Sealing (barrier, panel hermetic, environment resistant, non-sealed).
- (f) Type of coupling (bayonet lock, pull-off, push-pull, threaded, lanyard release).
- (g) Temperature Category (min, max).
- (h) Technical features of contacts (crimped, solder, wire wrap).
- (j) Details of cables or wires.
- (k) Accessories (back end fittings).
- (l) Electromagnetic compatibility, (EMC, EMP etc).
- (m) Availability of tooling (crimping, extraction, insertion).
- (n) Scoop proof.
- (p) Mass.

6 Guidance on the Selection Criteria for Connector Filtered Contacts

6.1 The following gives guidance to the criteria used when specifying filtered contacts:

- (a) define the cut-off frequency versus the band pass for the data being passed and the intended operating conditions eg characteristic impedance, current carrying condition etc.
- (b) specify the minimum or maximum capacitance that the system can tolerate.
- (c) establish the minimum or maximum insertion loss at a specific frequency or for a band of frequencies.
- (d) define the working voltages. If the system must operate with spike voltage requirements, then the magnitude and duration must be specified.
- (e) the type of filter eg Pi, T, L, C etc.
- (f) specify the connector series or specification that the filter contact must mate with.

6.1 (Contd)

- (g) specify the overall length of the filter contact.
- (h) specify the filter contact termination eg solder cup, crimp, PC6, solderless wrap etc.
- (i) specify if filter contacts of different cut-off frequencies and attenuation characteristics can be mixed within the same connector pattern.
- (j) specify the system environment eg vibration, shock, humidity, temperature range, thermal shock temperatures degree of environmental sealing etc.
- (k) specify lightning or NEMP voltages if required.

NOTE 1: Changes in characteristic impedance can affect the performance of the filter contact.

NOTE 2: Temperature can affect the insertion loss and overall performance.

NOTE 3: Filters may have negative - positive - zero - temperature - coefficient (NPO) materials.

7 Selection, Cross Reference Tables and Guide Sheets

7.1 Basic selection data, contact arrangements, specifications, characteristics and typical applications for connectors are given in Tables A, B, C, and D, these Tables also show the related Pattern Numbers.

7.2 Guide sheets for connectors are contained in the annex to each section, reference A-001.

8 Qualification Approval

8.1 It is essential that having selected a particular connector from the ranges listed in the British Standard or Defence Standard series that reference is made to ascertain that a Qualification Approval Certificate is extant for the connector(s) selected.

Def Stan 59-59	Electrical/Electronic components for Defence use - Services qualified products list including components of assessed quality.
EPIC	Electronic Part Information Centre
CECC MUAHAG	Vol 3 Preferred product (Connectors)
CECC 00 200	CECC Qualified Products List
PD 9002	BS 9000 and BS CECC qualified products list
CODUS	Component Databank University of Sheffield

8.1.1 If there is no such Qualification Approval certificate extant at the time of selection, then the procedure given in Def Stan 59-36 shall apply.

NOTE: At time of printing, Qualification Approval testing against some of the specifications listed may not yet be complete (see **8.1**).

Section Two. Connectors Electrical, Circular

1 Scope

This Section describes various circular connectors which are of the multi contact type.

2 Types of Couplings

2.1 Connectors may be coupled together as follows:

2.1.1 Bayonet. A quick coupling device for mating connectors utilizing projections riding in ramps and providing jacking and locking features with limited rotation.

2.1.2 Pull-Off. A coupling in which unlocking is achieved by an axial pull.

2.1.3 Push-Pull. A quick axial coupling device with self locking and unlocking features. Unlocking is achieved by an axial pull on the coupling ring.

2.1.4 Threaded. A means of coupling by engaging screw threads present on the mating components.

2.1.5 Lanyard release. A quick disconnect connector designed to separate when a specified force is applied to the coupling device through a lanyard. Connector may be either threaded or bayonet coupled with lanyard release.

3 Connector Housing

3.1 For the definition see **3.2.6**. In addition the following is applicable.

3.1.1 The normal connector housing provides housing to housing continuity. Some connector housings are also available with non conductive finishes.

3.1.2 The connector housing size range may be quoted as a number 8 to 36. Each unit number represents 0.0625 inches diameter of the female connector housing outside diameter.

3.1.3 The contact arrangement refers to a standard configuration and does not necessarily relate to the number of contacts within the housing size. (See tables A-1 and A-2).

DEF STAN 59-35 (PART 0)/3
SECTION 2 (CONTD)

4 Contacts

4.1 Crimp contacts used in different applications have a size designation related to conductor wire size as follows:-

(a) <u>Contact size</u>	<u>Conductor size</u>	<u>CMA</u>
22D	22, 24, 26 and 28	633, 434, 244 and 169
20	20, 22 and 24	1178, 633 and 434
16	16, 18 and 20	2650, 1841 and 1178
12	12 and 14	5966 and 3305
8	8	16597
0	0	101064

NOTE: Letter D indicates contact barrel is modified.

High Density contact arrangements are defined as having individual contact centre line spacing of less than 2.5 mm.

(b) Screened Coaxial:

Contact size

16
12
8

(c) Concentric Contacts:

Contact size

10
8

NOTE: A circular mil is the area of 1 mil diameter where
1 mil = 0.001 in = 0.0254 mm. The circular mil area is calculated using the
formula d^2n where:

d is the nominal diameter of each individual strand (in mils)

n is the number of individual strands in the conductor.

TABLE A-1
SELECTION CHART FOR CONNECTORS ELECTRICAL, CIRCULAR

Typical Application	Pattern Numbers	MOD Pattern Numbers	Notes	Connectors Electrical								Contacts							Defence Standard Number	Guide Sheet Reference							
				Coupling			Housing Material			Environment		Terminations			Finish		Shape	Current Rating Amps			Qty		Conforms to BS 9521				
				Bayonet	Screw	Other	Aluminium	Brass	Other Metal	Insulated	Barrier Sealed	Hermetic	Environment Resistant	Climatic Category	Solder	Crimp	Wire Wrap	Other			Gold	Silver		Other	Circular	Other	Maximum for Largest Contact
General Purpose	9522 N0001	603	Derived MIL-C-26482 Series I	X			X				X	55/125/56		X			X		X			23	2	61	X	59-35 (PT 3) Sec 5	A-001
General Purpose Avionic, Airframe Fit	9522 N0003 9520 G0002	614	N Spec derived MIL-C-38999 Series II G Spec conforms to all requirements of MIL-C-38999 Series II	X			X			X	X	65/155/56	X	X			X		X			23	3	128	X		A-002
Lightweight, General Purpose Avionic and Airframe Fit	9522 F0012	615	100% Scoop Proof derived LN 29279	X			X			X		65/175/56		X			X		X			23	3	128	X	B-003	A-003
General Purpose	9522 F0017	105	Derived MIL-C-26482 Series I, including Coaxial Contacts	X			X					55/125/56	X			X	X		X			23	2	61	-	59-35 (PT 3) Sec 7	A-004
Heavy Duty, General Purpose Use, Marine Applications	9522 F0020	608	Inserts derived from MIL-C-26482		X			X	X	X	X	55/125/56	X	X			X	X	X			45	2	61	X	59-35 (PT 5)	A-005
Heavy Duty, General Purpose Power Distribution	9522 F0024	128	Inserts derived from MIL-C-5015		X				X	X		55/100/56	X					X	X			150	3	37	-	-	A-006
Telephone Use	9522 F0025					X						40/70/21						X		X		6	4	28	-		A-007
Special Purpose With Air Frame Fit With EMI/RFI/EMP	9522 F0027		Filter Contact connector, interchangeable with 9522 N0001, F0017, F0047	X			X			X		55/155/56		X				X	X			(75P (5F)	3	61	-		A-008

2-3

See page 2-12 for notes applicable to Tables.

TABLE A-1 (CONTD)
SELECTION CHART FOR CONNECTORS ELECTRICAL CIRCULAR

Typical Application	Pattern Numbers	MOD Pattern Numbers	Notes	Connectors Electrical								Contacts							Defence Standard Number	Guide Sheet Reference							
				Coupling		Housing Material		Environment				Terminations			Finish		Shape	Current Rating Amps			Qty						
				Bayonet	Screw	Other	Aluminium	Brass	Other Metal	Insulated	Barrier Sealed	Hermetic	Environment Resistant	Climatic Category	Solder	Crimp	Wire Wrap	Other			Gold	Silver	Other	Circular	Other	Maximum for Largest Contact	Minimum
General Purpose Avionic and Airframe Fit	9522 F0029 9520 G0001	616	100% Scoop Proof and EMC hard. F Spec derived MII-C-38999 Series I. G Spec conforms to all requirements of MII-C-38999 Series I	X			X					X							X			23	3	128	X		A-009
General Purpose	9522 F0030	121	Derived MII-C-5015		X			X		X		X					X	X		X		92	1	47	-	59-35(PT 1)Sec 8	A-010
General Purpose Power Distribution	9522 F0032	121B	Inserts derived from MII-C-5015	X			X		X	X		X	X			X	X		X		150	1	61	-	59-35(PT 1)Sec 8B	A-011	
General Purpose Avionic and Airframe Fit	9522 F0039 9520 G0003	-	High Performance and EMC, 100% Scoop Proof. F Spec derived MII-C-38999 Series II. G Spec conforms to all requirements of MII-C-38999 Series II		X		X			X		X							X		23	3	128	X		A-012	
Databus	9522 F0041				X		X			X				X							Databus				X	A-013	
Databus	9522 F0043	-			X			X				X			X						Databus	1	-	X		A-014	
Mains Applications	9522 F0053	-			X		X		X			X				X					5	3	-			A-015	
General Purpose Avionics and Airframe Fit	CECC 75-201 XXX	602	Intermatable with Patterns 9522 N0001 and F0017	X			X		X			X	X			X			X		23	2	61	X	INTERIM 59-56(PT 1)	A-016	
Telephone Field	-	100	10 pr Coupler Butting	X			X			X		X						X	X		1	-	20		59-35(PT1) Sec 14	A-017	

See page 2-12 for notes applicable to Tables.

TABLE A-2 (CONTD)
CONNECTORS ELECTRICAL, CIRCULAR
CROSS REFERENCE OF CONTACTS/CONTACT ARRANGEMENTS

TOTAL NO OF CONTACTS (See Note 4)	CONTACT ARRANGEMENT	SIZE, DIMENSIONS (mm) AND NUMBER OF CONTACTS										CONNECTOR, ELECTRICAL, CIRCULAR						
												PATTERN NUMBER						
		9.06	5.72	3.61	3.175	2.38	1.981	1.587	1.02	0.70	MOD 100	9522 F0030 (121)	9522 F0032 (121R)	9522 F0024 (12R)	75-201 XXX (602)	9522 F0020 (608)	9522 F0025	9522 F0053
6	10-06									6				X	X			
	10-06A/10-98									6				X				
	14S-06									6			X	X				
	18-12									6			X		X			
	20-22				3						3			X				
	28-22			3							3			X	X			
	28-42				4						2				X			
7	36-51		5				1							X				
	16S-01									7				X	X			
	20-15						7							X				
	24-02						7								X			
	28-10			2	2		3							X	X			
8	12-08									8					X			
	16-08									8					X	X		
	18-08						8								X			
	22-18									8				X				
	22-23						8							X		X		
9	20-18						3			6				X				
	20-21						1			8				X	X			
	24-11				3		6							X	X			
	12-10									10					X	X		
10	18-01									10				X	X			
11	18-11									11				X	X			
12	14-12									4	8				X			
	22-12						12								X			
	28-51				12									X				
	28-75						7			5				X				
14	22-19									14				X	X			
	28-20						10			4				X				
15	14-15									1	14				X	X		
	20-16									16				X	X			
16	24-07						2			14				X	X			
	20-29									17				X				

See page 2-12 for notes applicable to Tables.

2-6

TABLE -2 (CONTD)
CONNECTORS ELECTRICAL, CIRCULAR
CROSS REFERENCE OF CONTACTS/CONTACT ARRANGEMENTS

TOTAL NO OF CONTACTS (See Note 4)	CONTACT ARRANGEMENT	SIZE, DIMENSIONS (mm) AND NUMBER OF CONTACTS									CONNECTOR, ELECTRICAL, CIRCULAR							
		9.06	5.72	3.61	3.175	2.38	1.981	1.587	1.02	0.70	PATTERN NUMBER							
											100	9522 F0030	9522 F0032	9522 F0024	CECC 75-201 XXX	9522 F0020	9522 F0025	9522 F0053
		0	4	8	10	12	14	16	20	23	100	(121)	(121B)	(128)	(602)	(608)		
18	14-18								18						X			
19	14-19								19						X	X		
	20A-48							19				X						
	22-14							19			X	X	X					
	24-19					19									X			
21	22-21							21						X	X			
22	28-21					4		18			X	X						
23	16-23							1	22						X			
	16-99							2	21							X		
	32-06		2	3		2		16			X	X						
24	24-28							24			X							
26	16-26								26					X	X			
	29-12							26			X							
28	30-028																X	
31	24-31							31							X			
32	18-32								32						X	X		
35	32-07					7		28			X	X						
	36-15							35			X							
36	22-36							36						X				
37	03-37								37		X							
	22-14							37					X					
	28-21							37			X	X	X					
39	20-39						2	37						X	X			
41	20-41								41					X	X			
	22-41							14	27					X	X			
47	36-07					7		40										
48	36-10							48			X	X						
55	22-55								55					X	X			
61	24-61								61					X	X			
62	03-62								62		X							

See page 2-12 for notes applicable to Tables.

2-7

TABLE A-2 (CONT'D)
CONNECTORS ELECTRICAL, CIRCULAR
CROSS REFERENCE OF CONTACTS/CONTACT ARRANGEMENTS

TOTAL NO OF CONTACTS (See Note 4)	CONTACT ARRANGEMENT	SIZE, DIMENSIONS (mm) AND NUMBER OF CONTACTS									CONNECTOR, ELECTRICAL, CIRCULAR								
											PATTERN NUMBER								
		5.72	3.61	3.175	2.38	1.981	1.587	1.02	0.76	0.70	9522 N0001	9522 /9520 N0003/G0002	9522 F0012	9522 F0017	9522 F0027	9522 /9520 F0029/G0001	9522 /9520 F0039/G0003	9522 F0041	9522 F0043
		4	8	10	12	14	16	20	22D	23	(603)	(614)	(615)	(105)	(616)				
1	08-01			1 CC															X
	10-70		1								X			Y					
	11-01		1 CC													X			
	-		1 CC															X	
2	08-02							2						X					
	10-02						2				X			X					
	14-02				2						X			X					
3	08-33							3			X			X	X				
	8-3A/08-98							3			X	X		X					
	09-98							3					X		X				
	12-03						3				X		X	Y		X		Y	
	13-03						3								X		X		
	18-74		3 CC											X					
4	08-04							4						X					
	12-04							4				X		X					
	13-04							4							X				
	14-04				4								X						
	15-04						4									X			
	16-04				4						X								
	16-71			4 CC							X								
	18-75		4 CC											X					
	18-76		1 CC		3 CC									X					
	20-75		4 CC											X					
21-75		4 CC											X						
5	10-05							5						X					
	11-05							5										Y	
	14-05						5				X	Y	X	X					
	14-22				4			1			X			X					
	15-05						5								X		Y		
6	08-35								6			X	X						
	09-35								6						X		X		
	10-06							6			X		X	X					
	10-98							6				X							
	11-98							6							X		Y		
	16-06				6								X						
	17-06				6										X		X		
	24-79		5 CC					1						X					

See page 2-12 for notes applicable to Tables.

TABLE A-2 (CONTD)
CONNECTORS, ELECTRICAL, CIRCULAR
CROSS REFERENCE OF CONTACTS/CONTACT ARRANGEMENTS

TOTAL NO OF CONTACTS (See Note 4)	CONTACT ARRANGEMENT	SIZE, DIMENSIONS (mm) AND NUMBER OF CONTACTS									CONNECTORS ELECTRICAL, CIRCULAR								
											PATTERN NUMBER								
		5.72 4	3.61 8	3.175 10	2.38 12	1.981 14	1.587 16	1.02 20	0.76 22D	0.70 23	9522 N0001 (603)	9522 /9520 N0003/G0001 (614)	9522 F0012 (615)	9522 F0017 (105)	9522 F0027	9522 /9522 F0029/G0001 (616)	9522 /9520 F0039/G0003	9522 F0041	9522 F0043
7	10-07							7			X			X					
	10-99							7			X	X	X	X					
	11-99							7								X	X		
	22-67		7 CC											X					
8	12-08							8				X	X	X					
	13-08							8								X	X		
	16-08							8			X	X	X	X					
	16-80		2 CC					6						X					
	17-08							8								X	X		
	18-08				8						X			X					
	18-80		2 CC					6						X					
	18-98				4			4			X								
	20-73		2 CC					6						X					
9	18-71		1 CC		8									X					
	22-09				5			4			X								
	22-71		7 CC					2						X					
10	12-10							10			X			X	X				
	12-98							10				X							
	23-98							10								X	X		
	20-71				8 CC			2						X					
	22-76				10 CC									X					
	24-73		10 CC											X					
11	18-11							11			X	X	X	X					
	19-11							11								X	X		
	20-11				11								X						
	21-11				11											X	X		
	25-11			9				2										X	
12	14-12							4	8		X			X					
	14-97							4	8			X	X						
	15-97							4	8							X	X		
	16-11		1 CC						11					X					
	22-12				12														

See page 2-12 for notes applicable to Tables.

2-9

TABLE A-2 (CONTD)
CONNECTORS, ELECTRICAL, CIRCULAR
CROSS REFERENCE OF CONTACTS/CONTACT ARRANGEMENTS

TOTAL NO OF CONTACTS (See Note 4)	CONTACT ARRANGMENT	SIZE, DIMENSIONS (mm) AND NUMBER OF CONTACTS									CONNECTOR ELECTRICAL, CIRCULAR PATTERN NUMBER								
		5.72	3.61	3.175	2.38	1.981	1.587	1.02	0.76	0.70	9522 N0001	9522 /9520 N0003/G0002	9522 F0012	9522 F0017	9522 F0027	9522 /9520 F0029/G0001	9522 /9520 F0039/G003	9522 F0041	9522 F0043
		4	8	10	12	14	16	20	22D	23	(603)	(614)	(615)	(105)		(616)			
31	24-31																		
32	18-32																		
	19-32																		
	22-32																		
	23-32																		
36	22-36																		
37	14-35																		
	15-35																		
	24-37																		
	25-37																		
39	20-39																		
	21-39																		
41	20-41																		
	21-41																		
	22-41																		
43	25-43																		
	24-43																		
46	24-46																		
	24-70																		
	25-46																		
47	24-67																		
49	24-71																		
53	22-53																		
	23-53																		
55	16-35																		
	17-35																		
	22-55																		
	23-55																		
56	24-04																		
	25-04																		
61	24-61																		
64	25-61																		
66	25-64																		
	18-35																		
	19-35																		
67	18-45																		
	19-45																		
79	20-35																		
	21-35																		
100	22-35																		
	23-35																		
128	24-35																		
	25-35																		

2-10

See page 2-12 for notes applicable to Tables

TABLE A-2 (CONTD)
CONNECTORS ELECTRICAL, CIRCULAR
CROSS REFERENCE OF CONTACTS/CONTACT ARRANGEMENTS

TOTAL NO OF CONTACTS (See Note 4)	CONTACT ARRANGEMENT	SIZE, DIMENSIONS (mm) AND NUMBER OF CONTACTS									CONNECTOR ELECTRICAL, CIRCULAR PATTERN NUMBER								
		5.72	3.61	3.175	2.38	1.981	1.587	1.02	0.76	0.70	9522 N0001	9522 /9520 N0003/G0002	9522 F0012	9522 F0017	9522 F0027	9522 /9520 F0029/G0001	9522 /9520 F0039/G0003	9522 F0041	9522 F0043
		4	8	10	12	14	16	20	22D	23	(603)	(614)	(615)	(105)		(616)			
13	10-35																		
	11-35														X	X			
	16-13														X	X			X
	17-13									13					X				
14	16-76				6 CC					8				X					
	18-72				4 CC					10				X					
	20-70		4 CC							10				X					
15	14-15									1	14		X	X	X	X			
	15-15									1	14					X		X	
	16-70				1 CC					14				X					
16	20-16									16		X	X	X	X			X	X
	21-16									16								X	X
18	14-18									18			X	X					
	15-18									18						X		X	
19	14-19									19		X	X	X	X	X		X	X
	15-19									19						X		X	
	18-70				1 CC					18				X					
	22-70				6 CC					13				X					
	22-72				3 CC					12				X					
	24-19									19									
20	25-19									19									
	17-20				4					4						X		X	X
21	22-21									21		X	X	X	X				
	23-21									21									
22	12-35														X			X	X
	13-35														22			X	X
23	16-23									1	22	X			X				
	16-99									2	21	X	X	X					
	17-99									2	21					X		X	X
	22-67				3 CC					20				X					
24	24-24									12	12			X					
	25-24									12	12							X	X
26	16-26										26	X	X	X	X	X		X	X
	17-26										26					X		X	
	20-72				3 CC					23				X					
28	18-28									2	26	X	X	X				X	X
	19-28									2	26							X	X
29	24-29									29				X					
	25-29									29								X	X
30	18-30									1	29			X				X	X
	19-30									1	29					X		X	X
	25-20				3 CC					4 CC	13	10						X	X

See page 2-12 for notes applicable to Tables.

2-11

DEF STAN 59-35 (PART 0)/3
SECTION 2 (CONCLD)

Notes Applicable to Tables

- 1** Contact current rating is quoted as maximum for the largest contact in the connector range. For other contact current ratings see appropriate detail specification.
- 2** The amount of current that may be passed by a contact could be limited by the bunched heating effect and temperature related to all current carrying contacts within a connector.
- 3** Where N/A appears in a column of a Table it means that the column heading is not applicable to that particular connector.
- 4** Tables of cross reference for contacts/contact arrangements list the number of contacts in ascending contact and shell sizes.
- 5** The BS detail specification number without the letters BS is used as the pattern number for connectors electrical where appropriate. The appropriate British Standard/Def Stan listing is shown on page 5.
- 6** The dimensions of contacts given in Table A-1 and A-2 are nominal pin diameters at the mating end.
- 7** The following abbreviation is used in Table A-2:
CC for concentric contacts
- 8** BS G specifications shown in Table A-1 will eventually supersede the BS F and N specifications with which they are bracketed.

Def Stan Guide Sheets for Connectors Electrical, Circular

A.1 This Annex contains Guide Sheets for connectors, electrical, circular for dc and low frequency application for Ministry of Defence use.

A.2 Defence Standard Guide Sheets give a summary of some technical information which will enable designers or users to determine whether or not the candidate connector patterns might be suitable to meet the requirement for a particular application. Final selection should only be made after full consideration of any specific Service requirements and all the relevant features and performance parameters of the candidate patterns. This will require study and definitive interpretation of the relevant detail specifications. Attention should also be given to the NOTE on page 2 of this Standard.

A.3 Tabulated below is a list of individual Guide Sheets which have been prepared for connectors electrical, circular, together with Standards related to this Guide.

GUIDE SHEET REFERENCE	BS CECC PATTERN NUMBER	DEF STAN 59-35 REFERENCE	MOD PATTERN NUMBER	PAGE NUMBER
A/001	9522 N0001	PART 3 SECT 5	603	A-3
A/002	9522 N0003/ 9520 G0002	+ PART 3 SECT 1	614	A-5
A/003	9522 F0012	+ PART 3 SECT 2	615	A-7
A/004	9522 F0017	PART 3 SECT 7	105	A-9
A/005	9522 F0020	PART 5	608	A-11
A/006	9522 F0024	-	128	A-13
A/007	9522 F0025	-	-	A-15
A/008	9522 F0027	-	-	A-17
A/009	9522 F0029/ 9520 G0001	+ PART 3 SECT 3	616	A-19
A/010	9522 F0030	PART 1 SECT 8	121	A-21
A/011	9522 F0032	PART 1 SECT 8B	121B	A-23
A/012	9522 F0039/ 9520 G0003	-	-	A-25
A/013	9522 F0041	-	-	A-27
A/014	9522 F0043	-	-	A-29
A/015	9522 F0053	-	-	A-31
A/016	CECC 75201XXX	DEF STAN 59-56 PART 1	602	A-33
A/017	- -	PART 1 SECT 14	100	A-35

NOTE 1: MOD pattern numbers are no longer issued for connectors electrical, pattern numbers now used are the BS Detail Specification number without the letters BS eg Pattern 9522 N0001.

NOTE 2: Connector illustrations shown in Guide Sheets are not to scale.

+ Not yet published

Issued January 1990

DEF STAN 59-35 (PART 0)/3

SECTION 2

ANNEX A (CONTD)

A.4 If any difficulties arise from the information contained in the Guide Sheets, then clarification should be sought from the Master Specification Office (MSO) who is the consulting authority for Connectors electrical (LF) on behalf of the Ministry of Defence. The MSO may be contacted at the following address:

Procurement Executive
Ministry of Defence
Electronic Components Group RSRE
Empress State Building
Lillie Road
Fulham
LONDON SW6 1TR

Defence Standard Guide Sheet A/001

Connectors Electrical, Circular, Pattern Number 9522 N0001

(Formerly MOD Pattern Number 603)

(NATO Stock Numbers are listed in Def Stan 59-35 (Part 3) Section 5)

1 Description

1.1 A multicontact low profile, bayonet coupled, non scoop proof, non barrier sealed environmental resistant with removable front release, rear removable crimp contacts.

1.2 Intermateable and intermountable with Patterns 9522 F0017, CECC 75 201XXX Intermountable with Patterns 9522 F0012.

2 Pattern 9522 N0001 - Illustration

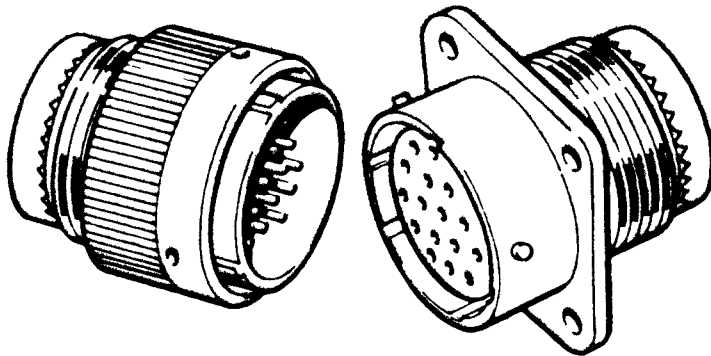

2.1 Characteristics

2.1.1	Environmental category	55/125/56
2.1.2	Low air pressure severity	44 mbars
2.1.3	Number of contacts	2, 3, 4, 5, 6, 7, 8, 9, 10, 11, 12, 15, 16, 19, 21, 23, 26, 28, 32, 36, 39, 41, 55 and 61
2.1.4	Contact termination style	Crimp
2.1.5	Maximum current rating at 85°C:	
2.1.5.1	Per individual contact in isolation	7.5 amps, size 20 contact 13 amps, size 16 contact 23 amps, size 12 contact
2.1.5.2	Per contact through all contacts simultaneously	5 amps, size 20 contact 10 amps, size 16 contact 20 amps, size 12 contact

DEF STAN 59-35 (PART 0)/3

SECTION 2

ANNEX A (CONTD)

- | | | |
|---------------|--|--|
| 2.1.6 | Contact finish | Gold plated |
| 2.1.7 | dc or ac peak Working voltage at sea level | 700 volts - Voltage rating 1
200 volts - Voltage rating 2 |
| 2.1.8 | Polarization | By housing keys and keyways, or by angular disposition of the insert |
| 2.1.9 | Sealing | Environmental resistant, non-barrier sealed |
| 2.1.10 | Housing material | Aluminium alloy |
| 2.1.11 | Housing finish | Olive drab chromate conversion over Cadmium plate |

3 Application - Typical

- 3.1** General purpose.
- 3.2** Suitable for cable to panel connections in an exposed environment.
- 3.3** Quick connect/disconnect requirements.
- 3.4** Suitable for high density contact arrangements.
- 3.5** Available with grounding springs for RFI suppression.

4 Specification

Connectors pattern number 9522 N0001 meet the requirements of the following specifications.

BS 9522 N0001

Def Stan 59-35 (Part 3) - Section 5 - Pattern 9522 N0001

5 Related Documents

BS 9520

BS 9522

Def Stan 59-35 (Part 3) - General requirements

Mil-C-26482-Series I

Defence Standard Guide Sheet A/002

Connectors Electrical, Circular, Pattern Number 9522 N0003/9520 G0002
(Formerly MOD Pattern Number 614)

1 Description

1.1 A multicontact low profile, bayonet coupled, non scoop proof, non barrier sealed, environmental resistant with removable rear release crimp contacts. Fixed items available with panel and barrier sealed, environment resistant with non-removable solder contacts.

2 Pattern 9522 N0003/9520 G0002 - Illustration

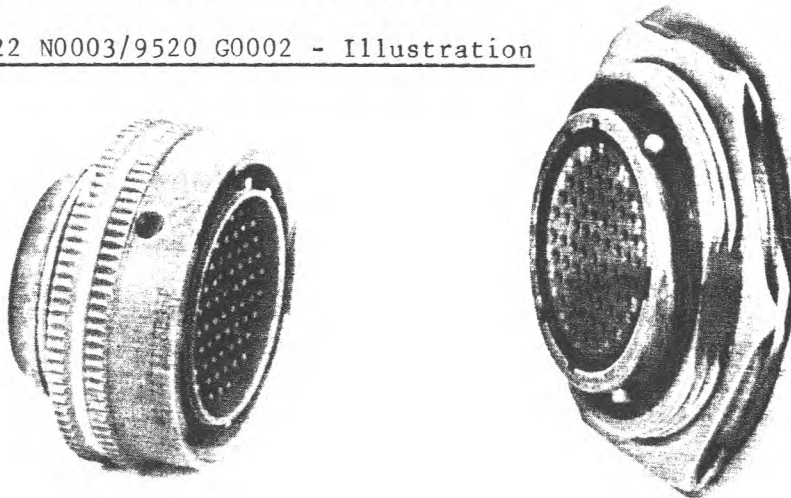

2.1 Characteristics

- | | | |
|----------------|---|---|
| 2.1.1 | Environmental category | 65/175/56 |
| 2.1.2 | Low air pressure severity | 10 mbars |
| 2.1.3 | Number of contacts | 3, 4, 5, 6, 8, 10, 11, 12, 13, 15, 16, 18, 19, 21, 22, 26, 32, 37, 39, 41, 55, 61, 66, 79, 100 and 128 |
| 2.1.4 | Contact termination style | Solder, crimp. Fixed items available with solder styles |
| 2.1.5 | Maximum current rating at 125°C | |
| 2.1.5.1 | Per individual contact in isolation | 5 amps, Size 22D contact
7.5 amps, Size 20 contact
13 amps, Size 16 contact
23 amps, Size 12 contact |
| 2.1.5.2 | Per contact through all contacts simultaneously | 3 amps, size 22D contact
5 amps, size 20 contact
10 amps, size 16 contact
20 amps, size 12 contact |

DEF STAN 59-35 (PART 0)/3

SECTION 2

ANNEX A (CONTD)

2.1.6	Contact finish	Gold plated
2.1.7	dc or ac peak Working voltage at sea level	600 volts - Voltage rating M 800 volts - Voltage rating 1 1000 volts - Voltage rating 2
2.1.8	Polarization	By housing keys and keyways
2.1.9	Sealing	Barrier-sealed and non barrier-sealed types available
2.1.10	Housing material	Aluminium alloy
2.1.11	Housing finish	Clear chromate cadmium over nickel plate. Other finishes are available

3 Application - Typical

3.1 Low profile general purpose avionic, airframe fit use. Only to be used where visual matings conditions apply.

3.2 Suitable for cable to panel connections in an exposed environment.

3.3 Quick connect/disconnect requirements.

3.4 Suitable for high density contact arrangements.

3.5 Available with grounding springs for RFI suppression.

4 Specification

Connectors pattern number 9522 N0003/9520 G0002 meet the requirements of the following specifications.

BS 9522 N0003

BS 9520 G0002

5 Related Documents

BS 9520

BS 9522

Def Stan 59-35 (Part 3) - General requirements

MIL-38999 Series II

Defence Standard Guide Sheet A/003

Connectors Electrical, Circular, Pattern Number 9522 F0012
(Formerly MOD Pattern Number 615)

1 Description

1.1 A multicontact lightweight, bayonet coupled, scoop proof, high density connector with rear release, and rear removable crimp contacts. Non barrier sealed or environmental resistant.

1.2 Intermountable with Patterns 9522 N0001, CECC 75 201XXX, 9522 F0017 and 9522 N0003

2 Pattern 9522 F0012 - Illustration

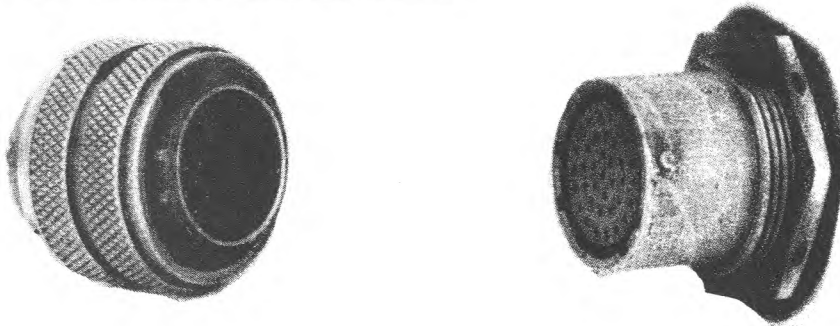

2.1 Characteristics

2.1.1	Environmental category	65/175/56
2.1.2	Low air pressure severity	10 mbars
2.1.3	Number of contacts	3, 4, 5, 6, 8, 10, 11, 12, 13, 14, 16, 18, 19, 21, 22, 26, 32, 37, 39, 41, 55, 61, 66, 79, 100 and 128
2.1.4	Contact termination style	Crimp
2.1.5	Maximum current rating at 125°C	
2.1.5.1	Per individual contact in isolation	5 amps, size 22D contact 7.5 amps, size 20 contact 13 amps, size 16 contact 23 amps, size 12 contact
2.1.5.2	Per contact through all contacts simultaneously	3 amps, size 22D contact 6 amps, size 20 contact 10 amps, size 16 contact 16 amps, size 12 contact

DEF STAN 59-35 (PART 0)/3

SECTION 2

ANNEX A (CONTD)

2.1.6	Contact finish	Gold plated
2.1.7	dc or ac peak working voltage voltage	600 volts - Voltage rating M 800 volts - Voltage rating 1 1000 volts - Voltage rating 2
2.1.8	Polarization	By housing key and keyways
2.1.9	Sealing	Environmental resistant non-barrier sealed
2.1.10	Housing material	Aluminium alloy
2.1.11	Housing finish	Olive drab chromate conversion over cadmium plate

3 Application - Typical

- 3.1** Lightweight, general purpose, avionic and airframe fit use.
- 3.2** Lightweight, 100% scoop proof, suitable for blind mating conditions also suitable for cable to panel connections in exposed environment.
- 3.3** Quick connect/disconnect requirements in bayonet coupled connectors.
- 3.4** Available with high density contact arrangements.
- 3.5** Available with grounding springs for RFI suppression.

4 Specification

Connectors pattern number 9522 F0012 meet the requirements of the following specification.

BS 9522 F0012

5 Related Documents

LN 29729
BS 9520
BS 9522

Defence Standard Guide Sheet A/004

Connectors Electrical, Circular, Pattern Number 9522 F0017
(Formerly MOD Pattern Number 105)

(NATO Stock Numbers are listed in Def Stan 59-35 (Part 3) Section 7)

1 Description

1.1 Multicontact connectors with bayonet coupling and non-removable solder contacts. Environmental resistant with barrier or barrier and panels seals.

1.2 Intermateable and intermountable with Patterns 9522 F0047 and 9522 N0001.

Intermountable with Patterns 9522 F0012.

2 Pattern 9522 F0017 - Illustration

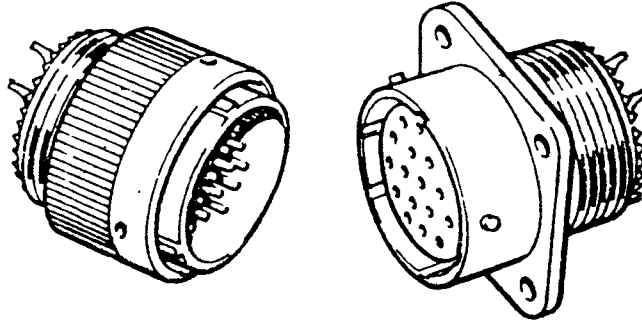

2.1 Characteristics

2.1.1	Environmental category	55/125/56
2.1.2	Low air pressure severity	44 mbars
2.1.3	Number of contacts	2, 3, 4, 5, 6, 7, 8, 9, 10, 11, 12, 14, 15, 16, 19, 21, 23, 26, 32, 36, 39, 41, 46, 47, 55 and 61 - plus arrangements including coaxial contacts
2.1.4	Contact termination style	Solder
2.1.5	Maximum current rating at 85°C:	
2.1.5.1	Per individual contact in isolation	7.5 amps, size 20 contact 13 amps, size 16 contact 23 amps, size 12 contact

DEF STAN 59-35 (PART 0)/3

SECTION 2

ANNEX A (CONTD)

- | | |
|--|--|
| 2.1.5.2 Per contact through all contacts simultaneously | 5 amps, size 20 contact
10 amps, size 16 contact
20 amps, size 12 contact |
| 2.1.6 Contact finish | Gold plated |
| 2.1.7 dc or ac peak Working voltage at sea level | 700 volts - Voltage Rating 1
1200 volts - Voltage Rating 2
1500 volts - Voltage Rating 3 |
| 2.1.8 Polarization | By housing key and keyways or by angular disposition of the insert |
| 2.1.9 Sealing | Environmental resistant with barrier or barrier and panel sealed. |
| 2.1.10 Housing material | Aluminium alloy |
| 2.1.11 Housing finish | Olive drab chromate conversion over cadmium plate |

3 Application - Typical

- 3.1** General purpose use.
- 3.2** Suitable for cable to panel connections in an exposed environment.
- 3.3** Quick connect/disconnect requirements.
- 3.4** Available with grounding springs for RFI suppression.

4 Specification

Connectors pattern number 9522 F0017 meet the requirements of the following specifications.

BS 9522 F0017

Def Stan 59-35 (Part 3) Section 7 - Pattern 9522 F0017

5 Related Documents

BS 9520

BS 9522

MIL-C-26482 Series I

Def Stan 59-35 (PART 3) - General requirements

Defence Standard Guide Sheet A/005

Connectors Electrical, Circular, Pattern Number 9522 F0020

(Formerly MOD Pattern Number 608)

(NATO Stock Numbers are listed in Def Stan 59-35 (Part 5))

1 Description

Multicontact connector with 2 start threaded quick release coupling. Front release, rear removable crimp and non removable solder contacts. Solder style are barrier and panel sealed, crimp style are environmental sealed.

2 Pattern 9522 F0020 - Illustration

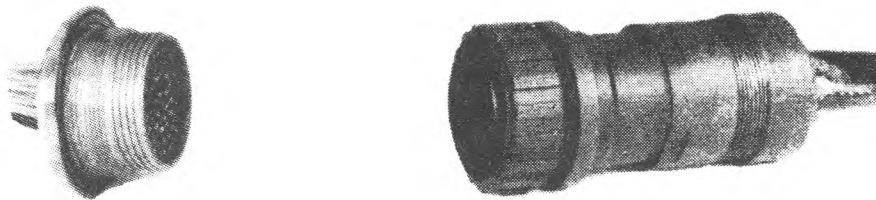

2.1 Characteristics

2.1.1	Environmental category	55/125/56
2.1.2	Low air pressure severity	44 mbars
2.1.3	Number of contacts	2, 3, 4, 5, 6, 8, 10, 11, 15, 16, 19, 21, 26, 32, 39, 41, 55 and 61
2.1.4	Contact terminations style	Solder or crimp
2.1.5	Maximum current rating at 85°C:	
2.1.5.1	Per individual contact in isolation	7.5 amps, size 20 contact 13 amps, size 16 contact 23 amps, size 12 contact 45 amps, size 8 contact
2.1.5.2	Per contact through all contacts simultaneously	3 amps, size 20 contact 10 amps, size 16 contact 20 amps, size 12 contact 40 amps, size 8 contact

DEF STAN 59-35 (PART 0)/3

SECTION 2

ANNEX A (CONTD)

- | | |
|---|--|
| 2.1.6 Contact finish | Silver or gold plated |
| 2.1.7 dc or ac peak Working voltage at sea level | 700 volts - Voltage rating 1
1250 volts - Voltage rating 2
1500 volts - Voltage rating 3 |
| 2.1.8 Polarization | By housing keys and keyways |
| 2.19 Sealing | Solder and adaptor connectors on barrier sealed units, with non-removable contacts |
| 2.1.10 Housing material | Nickel aluminium bronze |
| 2.1.11 Housing finish | Self finish |

3 Application - Typical

3.1 Heavy duty general purpose use - Suitable for marine application, ships and submarines.

3.2 Suitable for heavy duty cable to panel connections in an exposed environment.

4 Specification

Connectors pattern number 9522 F0020 meet the requirements of the following specification.

BS 9522 F0020

Def Stan 59-35 (Part 5) - Pattern 608

5 Related Documents

BS 9520

BS 9522

Defence Standard Guide Sheet A/006

Connectors Electrical, Circular, Pattern Number 9522 F0024
(Formerly MOD Pattern Number 128)

1 Description

Multicontact, barrier sealed, heavy duty electrical connectors, moulded plastic shell, with multi-start threaded couplings and non removable solder contacts. Primarily intended for power distribution.

2 Pattern 9522 F0024 - Illustration

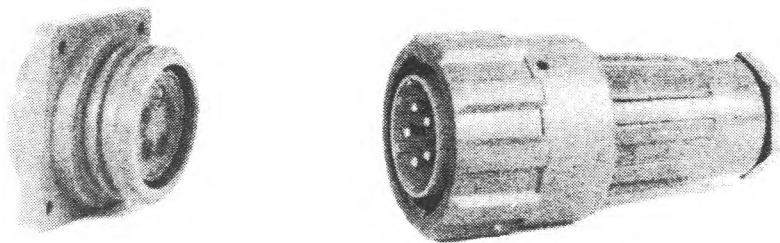

2.1 Characteristics

2.1.1	Environmental category	55/100/56
2.1.2	Low air pressure severity	300 mbar
2.1.3	Number of contacts	3, 4, 5, 6, 8, 10 and 37
2.1.4	Contact termination style	Crimp
2.1.5	Maximum current rating per individual contact at 70°C	140 amp
2.1.6	Contact finish	Silver plated
2.1.7	dc or ac peak Working voltage at sea level.	500 or 750 volts
2.1.8	Polarization	Key and keyways
2.1.9	Sealing	Barrier and panel sealed

Issued January 1990

DEF STAN 59-35 (PART 0)/3

SECTION 2

ANNEX A (CONTD)

2.1.10 Housing material Plastic fire retardent

2.1.11 Housing finish Self finish grey, black

3 Application - Typical

Heavy duty general purpose - for power distribution.

4 Specification

BS 9522 F0024

5 Related Documents

BS 9520

BS 9522

Defence Standard Guide Sheet A/007

Connectors Electrical, Circular, Pattern Number 9522 F0025

1 Description

Multicontact connectors, moulded plastic shell, with hermaphroditic coupling and cross hermaphroditic fork contacts. Barrier and panel sealed environment resistant. Primarily for telephone use.

2 Pattern 9522 F0025 - Illustration

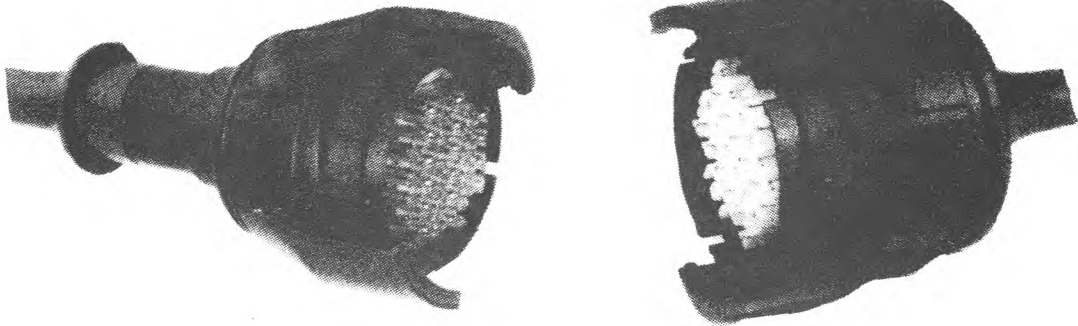

2.1 Characteristics

2.1.1	Environmental category	40/70/21
2.1.2	Low air pressure severity	630 mbars
2.1.3	Number of contacts	4, 28
2.1.4	Contact termination style	Solder
2.1.5	Maximum current rating at 55°C:	
2.1.5.1	Per individual contact in isolation	6 amps
2.1.5.2	Per contact through all contacts simultaneously	2 amps
2.1.6	Contact finish	Gold plated

Issued January 1990

DEF STAN 59-35 (PART 0)/3

SECTION 2

ANNEX A (CONTD)

- | | |
|--|--|
| 2.1.7 dc or ac peak Working voltage | 250 volts |
| 2.1.8 Polarization | Housing (shell) key and keyways and by angular disposition of contacts |
| 2.1.9 Sealing | Barrier and panel sealed environmental resistant |
| 2.1.10 Housing material | Glass filled nylon, flame retardent, natural finish |
| 2.1.11 Housing finish | Self finish black |

3 Application - Typical

Telephone use.

4 Specification

BS 9522 F0025

5 Related Documents

BS 9520

BS 9522

Defence Standard Guide Sheet A/008

Connectors Electrical, Circular, Pattern Number 9522 F0027

1 Description

Multicontact bayonet coupling circular connector, front release, rear removable crimp termination type male or female, filter, power and ground contacts. Suitable for use in equipment if EMI/RFI/EMP filtering is required. Barrier sealed and barrier panel sealed.

1.1 Intermateable with BS 9522 N0001, 9522 F0017 and CECC 75 201XXX.

2 Pattern 9522 F0027 - Illustration

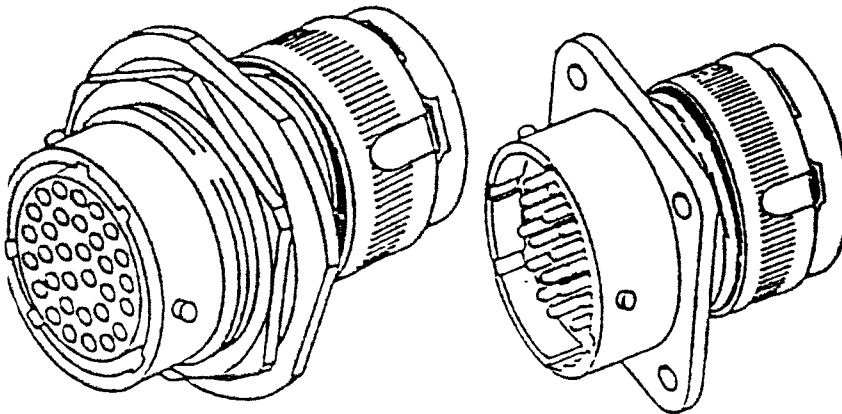

2.1 Characteristics

2.1.1	Environmental category	55/155/56
2.1.2	Low air pressure severity	44 mbars
2.1.3	Number of contacts	3, 6, 10, 19, 26, 32, 55 and 61
2.1.4	Contact termination style	Crimp
2.1.5	Maximum current rating at 115°C:	
2.1.5.1	Per individual contact in isolation	7.5 amps (power) 5 amps (filter)
2.1.5.2	Per contact through all contacts simultaneously	5 amps (power) 3 amps (filter)
2.1.6	Contact finish	Gold plated

DEF STAN 59-35 (PART 0)/3

SECTION 2

ANNEX A (CONTD)

- | | | |
|---------------|--|---|
| 2.1.7 | dc or ac peak Working voltage at sea level | 700 volt Power
200 volt Filter |
| 2.1.8 | Polarization | Housing (shell) keys and keyways or by angular disposition of insert |
| 2.1.9 | Sealing | Barrier sealed or barrier and panel sealed |
| 2.1.10 | Housing material | Aluminium alloy |
| 2.1.11 | Housing finish | Olive drab chromate conversion over cadmium plate or electroless nickel |

3 Application - Typical

3.1 Special purpose avionic and airframe fit where EMI/RFI/EMP filtering is required.

3.2 Provide EMI/RFI/EMP suppression in circuits when used with connectors 9522 N0001, 9522 F0017, CECC 75 201 XXX.

3.3 Quick connect/disconnect requirements.

4 Specification

BS 9522 F0027

5 Related Documents

BS 9520

BS 9522

Defence Standard Guide Sheet A/009

Connectors Electrical, Circular, Pattern Number 9522 F0029/9520 G0001
(Formerly MOD Pattern Number 616)

1 Description

1.1 A lightweight, bayonet coupled, scoop proof, high density connector with rear release and rear removable crimp contacts. Environmental resistant (Non barrier-sealed).

1.2 Intermountable with BS 9522 N0001, N0003, F0017 and CECC 75 201XXX.

2 Pattern 9522 F0029/9520 G0001 - Illustration

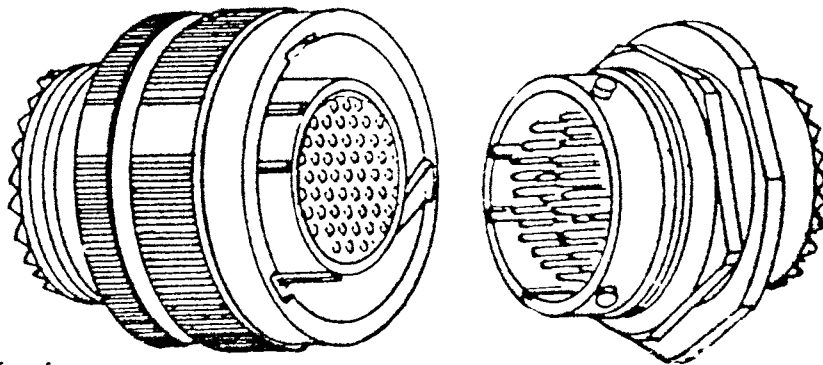

2.1 Characteristics

2.1.1	Environmental category	Class NA and NW 65/175/56 Class NF 65/200/56
2.1.2	Low air pressure severity	44 mbars
2.1.3	Number of contacts	2, 3, 4, 5, 6, 7, 8, 10, 11, 12, 13, 14, 15, 16, 18, 19, 21, 22, 23, 24, 26, 28, 29, 30, 32, 37, 39, 41, 43, 46, 53, 55, 61, 64, 66, 67, 79, 100 and 128
2.1.4	Contact termination style	Crimp
2.1.5	Maximum current rating at 125°C (Classes NA & NW) and 150°C (Class NF):	
2.1.5.1	Per individual contact in isolation	5 amps, size 22D contact 7.5 amps, size 20 contact 13 amps, size 16 contact 23 amps, size 12 contact
2.1.5.2	Per contact through all contacts simultaneously	3 amps, size 22D contact 6 amps, size 20 contact 10 amps, size 16 contact 16 amps, size 12 contact

DEF STAN 59-35 (PART 0)/3

SECTION 2

ANNEX A (CONTD)

2.1.6 Contact finish	Gold plated
2.1.7 dc or ac peak working voltage	550 volts - Voltage rating M 850 volts - Voltage rating 1 1250 volts - Voltage rating 2
2.1.8 Polarization	By housing keys and keyways
2.1.9 Sealing	Environmental resistant (non barrier-sealed)
2.1.10 Housing material	Aluminium alloy
2.1.11 Housing finish	Class NA: Clear chromate conversion of cadmium plate over nickel base Class NF: Electroless nickel Class NW: Olive drab chromate conversion over cadmium plate over nickel base.

3 Application - Typical

3.1 General purpose avionics and airframe fit. Scoop proof heavy duty suitable for blind mating conditions.

3.2 Suitable for cable to panel connections in an exposed environment.

3.3 Available with high density contact arrangements.

3.4 Quick connect/disconnect requirements.

3.5 Fitted with grounding springs for improved EMC shielding.

4 Specification

Connectors pattern number 9522 F0029/9520 G0001 meet the requirements of the following specification.

BS 9522 F0029

BS 9520 G0001

5 Related Documents

BS 9520

BS 9522

MIL-38999 Series I

Defence Standard Guide Sheet A/010

Connectors Electrical, Circular, Pattern Number 9522 F0030
(Formerly MOD Pattern Number 121)

1 Description

Multicontact connector with threaded couplings and non-removable solder contacts. All styles are environment resistant. Fixed connectors are barrier, or barrier and panel sealed.

2 Pattern 9522 F0030 - Illustration

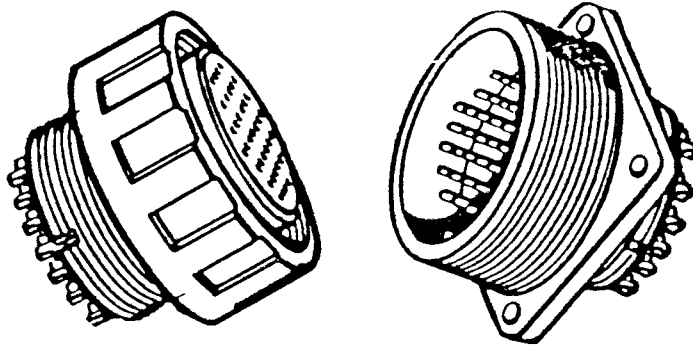

2.1 Characteristics

2.1.1	Climatic category	55/100/56
2.1.2	Low air pressure severity	300 mbars
2.1.3	Number of contacts	1, 2, 3, 4, 5, 6, 7, 8, 9, 10, 12, 14, 16, 17, 19, 22, 23, 24, 26, 35, and 37
2.1.4	Contact termination style	Solder
2.1.5	Maximum current rating at 70°C:	
2.1.5.1	Per individual contact in isolation	13 amps, size 16 contact 23 amps, size 12 contact 46 amps, size 8 contact 80 amps, size 4 contact
2.1.5.2	Per contact through all contact simultaneously	8 amps, size 16 contact 20 amps, size 12 contact 42 amps, size 8 contact 75 amps, size 4 contact

DEF STAN 59-35 (PART 0)/3

SECTION 2

ANNEX A (CONTD)

- | | |
|---|--|
| 2.1.6 Contact finish | Silver or gold plated |
| 2.1.7 dc or ac peak Working voltage at sea level | 350 volts - Voltage rating 1
500 volts - Voltage rating 2
750 volts - Voltage rating 3 |
| 2.1.8 Polarization | By housing keys and keyways with five different angular dispositions of the insert |
| 2.1.9 Sealing | Environmental resistant.
Fixed connectors are barrier or barrier and panel sealed |
| 2.1.10 Housing material | Aluminium alloy |
| 2.1.11 Housing finish | Olive drab chromate conversion over cadmium plate |

3 Application - Typical

- 3.1** General purpose.
- 3.2** Suitable for cable/wire to panel connections.

4 Specification

Connectors pattern number 9522 F0030 meet the requirements of the following specifications.

BS 9522 F0030

5 Related Documents

BS 9520
BS 9522
MIL-C-5015
MVEE FV(S) 23

Defence Standard Guide Sheet A/011

Connectors Electrical, Circular, Pattern Number 9522 F0032
(Formerly MOD Pattern Number 121B)

1 Description

Multicontact bayonet coupled connectors with crimped, rear insertion/front release removable crimp contacts, or soldered non-removable contacts. Environmental resistant.

2 Pattern 9522 F0032 - Illustration

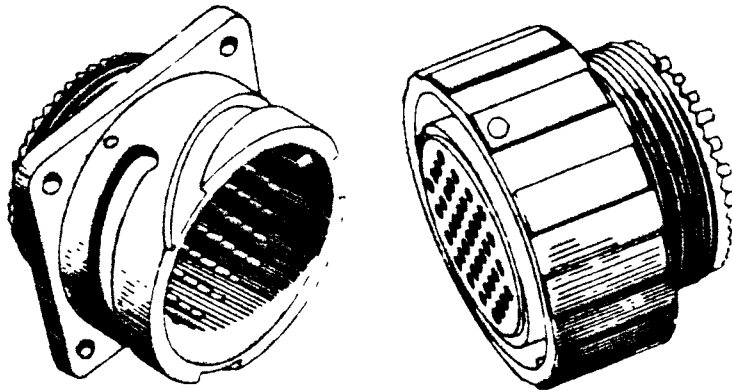

2.1 Characteristics

2.1.1	Environmental category	55/125/56
2.1.2	Low air pressure severity	300 m bars
2.1.3	Number of contacts	2, 3, 4, 5, 6, 7, 9, 10, 12, 14, 16, 19, 22, 23, 35, 37 and 48
2.1.4	Contact termination style	Solder or crimp
2.1.5	Maximum current rating at 85°C:	
2.1.5.1	Maximum current rating per individual contact at 85°C	13 amps, size 16 contact 23 amps, size 12 contact 46 amps, size 8 contact 80 amps, size 4 contact 150 amps, size 0 contact
2.1.5.2	per contact through all contacts simultaneously	10 amps, size 16 contact 20 amps, size 14 contact 42 amps, size 12 contact 75 amps, size 4 contact Not yet defined, size 0 contact

DEF STAN 59-35 (PART 0)/3

SECTION 2

ANNEX A (CONTD)

- | | |
|---|--|
| 2.1.6 Contact finish | Silver or gold plated |
| 2.1.7 dc or ac peak Working voltage at sea level | 350 volts - Voltage rating 1
700 volts - Voltage rating 2
1250 volts - Voltage rating 3
1750 volts - Voltage rating 4 |
| 2.1.8 Polarization | By housing keys and keyways and insert orientation |
| 2.1.9 Sealing | Panel and Barrier sealed or Environmental resistant |
| 2.1.10 Housing material | Aluminium alloy |
| 2.1.11 Housing finish | Olive drab chromote conversion over cadmium plate |

3 Application - Typical

- 3.1** General purpose.
- 3.2** Suitable for cable to panel connections.

4 Specification

Connectors pattern number 9522 F0032 meet the requirements of the following specifications.

BS 9522 F0032

5 Related Documents

BS 9520
BS 9522
NEPR 86
VG 95234
MIL-C-5015

Defence Standard Guide Sheet A/012

Connectors Electrical, Circular, Pattern Number 9522 F0039/9520 G0003

1 Description

Multicontact scoop proof connectors with triple start screw couplings and rear release rear removable crimp contacts. Environmental resistant.

2 Pattern 9522 F0039/9520 G0003 - Illustration

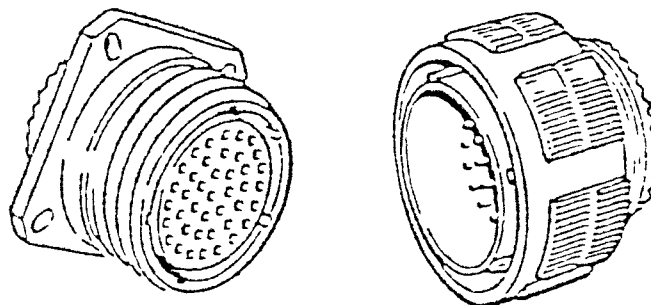

2.1 Characteristics

2.1.1	Environmental category	Class NW 65/175/56 Class NC and NF 65/200/56
2.1.2	Low air pressure severity	44 mbar
2.1.3	Number of contacts	1, 3, 4, 5, 6, 7, 8, 10, 11, 12, 13, 14, 15, 16, 18, 19, 20, 21, 22, 23, 24, 26, 28, 29, 30, 32, 37, 39, 41, 43, 46, 53, 55, 56, 61, 66, 67, 79, 100 and 128
2.1.4	Contact termination style	Crimp
2.1.5	Maximum current rating at 125°C (Class NW) and 150°C (Classes NC, NF &K):	
2.1.5.1	Per individual contact in isolation	5 amps, size 22D contact 7.5 amps, size 20 contact 13 amps, size 16 contact 23 amps, size 12 contact
2.1.5.2	Per contract through all contact simultaneously	3 amps, size 22D contact 6 amps, size 20 contact 10 amps, size 16 contact 16 amps, size 12 contact

Issued January 1990

DEF STAN 59-35 (PART 0)/3

SECTION 2

ANNEX A (CONTD)

2.1.6	Contact finish	Gold plated
2.1.7	dc or ac peak Working voltage voltage at sea level	550 volts - Voltage rating M 850 volts - Voltage rating 1 1250 volts - Voltage rating 2
2.1.8	Polarization	Housing (shell) key and keyways
2.1.9	Sealing	Environmental resistant (Non barrier sealed)
2.1.10	Housing material	Aluminium alloy
2.1.11	Housing finish	Class NC: Anodized (non conductive) Class NF: Electroless nickel Class NW: Olive drab chromate conversion over cadmium plate

3 Application - Typical

3.1 General purpose avionic and airframe fit.

3.2 Suitable for high performance of temperature applications including
EMP/RFI/EMI.

4 Specification

BS 9522 F0039

BS 9520 G0003

5 Related Documents

BS 9520

BS 9522

MIL-C-38999 Series III

Defence Standard Guide Sheet A/013

Connectors Electrical, Circular, Pattern Number 9522 F0041

1 Description

Databus (two-way shielded) circular electrical connectors, screw coupling with concentric crimp-type contacts. Environmental resistant (non Barrier sealed).

2 Pattern 9522 F0041 - Illustration

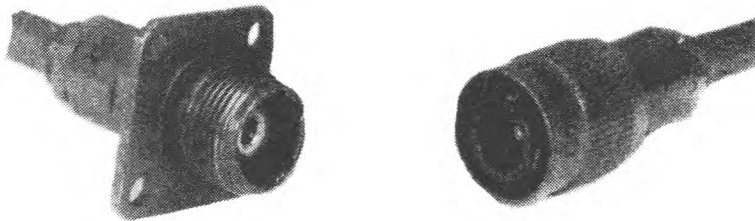

2.1 Characteristics

2.1.1	Environmental category	Class NF 65/200/56 Class NW 65/175/56
2.1.2	Low air pressure severity	44 mbars
2.1.3	Number of contacts	Single Concentric Contact
2.1.4	Contact termination style	Crimp
2.1.5	Maximum current rating per individual contact at 50°C	Contacts for signal data transmission use only. Current carrying capability not assessed
2.1.6	Contact finish	Gold plated

Issued January 1990

DEF STAN 59-35 (PART 0)/3

SECTION 2

ANNEX A (CONTD)

- | | |
|---|---|
| 2.1.7 dc or ac peak working voltage at sea level | 700 volt (between centre and intermediate contacts only) |
| 2.1.8 Polarization | Housing (shell) key and keyways |
| 2.1.9 Sealing | Environmental resistant (non barrier sealed) |
| 2.1.10 Housing material | Aluminium alloy |
| 2.1.11 Housing finish | Class NF Electroless nickel
Class NW olive drab chromate conversion over cadmium plate |

3 Application - Typical

3.1 Suitable for use in serial data bus applications primarily intended for airframe fit but also suitable for general purpose use.

4 Specifications

BS 9522 F0041

5 Related Documents

BS 9520

BS 9522

Def Stan 00-18

MIL-S-1553B

Defence Standard Guide Sheet A/014

Connectors Electrical, Circular, Pattern Number 9522 F0043

1 Description

Databus connector with threaded coupling and vibration proof locking mechanism, rear release, rear removable concentric crimp contacts. Barrier sealed or non-barrier sealed for use with data transmission system.

2 Pattern 9522 F0043 - Illustration



2.1 Characteristics

2.1.1	Environmental category	65/150/56
2.1.2	Low air pressure severity	44 mbars
2.1.3	Number of contacts	Single Concentric
2.1.4	Contact termination style	Crimp size 10
2.1.5	Maximum current rating per individual contact at 50°C	Contacts for signal data transmission use only. Current carrying capability not assessed
2.1.6	Contact finish	Gold plated
2.1.7	dc or ac peak Working voltage at sea level	680 volts
2.1.8	Polarization	Housing (shell) keys and keyways

Issued January 1990

DEF STAN 59-35 (PART 0)/3

SECTION 2

ANNEX A (CONTD)

- | | | |
|---------------|------------------|---|
| 2.1.9 | Sealing | Environmental sealed or
barrier sealed |
| 2.1.10 | Housing material | Aluminium alloy |
| 2.1.11 | Housing finish | Olive drab chromate conversion
over cadmium plate or electroless
nickel |

3 Application - Typical

3.1 Suitable for use in databus systems.

3.2 Lightweight avionic and airframe fit use.

4 Specification

BS 9522 F0043

5 Related Documents

BS 9520

BS 9522

Def Stan 00-18

Mil Spec 1553b

Defence Standard Guide Sheet A/015

Connectors Electrical, Circular, Pattern Number 9522 F0053

1 Description

Multi-contact circular connector with screw coupling and non-removable solder contacts for 250 volts mains application. This connector has been devised from BS 9522 F0014 brass style (coarse thread) but is not intermateable or intermountable with BS 9522 F0014 styles. It is specially designed for mains applications having a leading earth configuration.

2 Pattern 9522 F0053 - Illustration

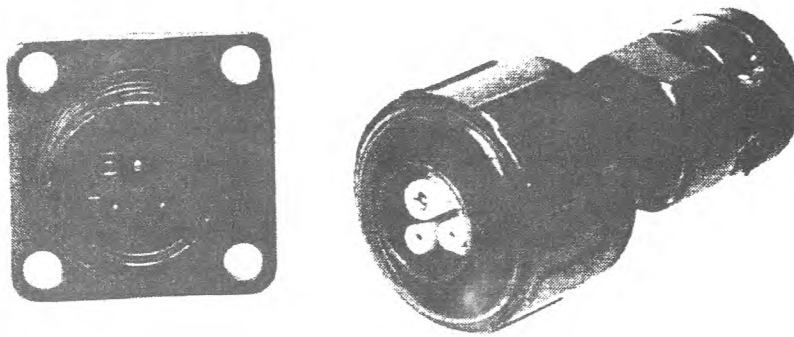

2.1 Characteristics

2.1.1	Environmental category	55/100/56
2.1.2	Low air pressure severity	300 mbars
2.1.3	Number of contacts	3
2.1.4	Contact termination style Solder	
2.1.5	Maximum current rating at 70 °C:	
2.1.5.1	Per contact through both contacts simultaneously simultaneously	5 amps
2.1.6	Contact finish	Gold Plated

Issued January 1990

DEF STAN 59-35 (PART 0)/3

SECTION 2

ANNEX A (CONTD)

- | | | |
|---------------|--|--|
| 2.1.7 | dc or ac peak Working voltage at sea level | 500 volts |
| 2.1.8 | Polarization | Fixed housing (shell) keys and keyways |
| 2.1.9 | Sealing | Environmental resistant.
Barrier and panel sealer |
| 2.1.10 | Housing material | Brass |
| 2.1.11 | Housing finish | Olive drab chromate conversion over cadmium plate |

3 Specification

BS 9522 F0053

4 Related Documents

BS 9520
BS 9522
BS 415

Defence Standard Guide Sheet A/016

Connectors Electrical, Circular, Pattern Number CECC 75-201 XXX
(Formerly MOD Pattern Number 602)

(NATO Stock Numbers are listed in INTERIM Def Stan 59-56 (Part 1))

1 Description

1.1 A multicontact low profile, bayonet coupled, non scoop proof, non barrier sealed, environment resistant with removable rear release crimp contacts. Fixed items available with panel and barrier sealed, environmental resistant with non removable solder contacts.

1.2 Intermateable and intermountable with Patterns 9522 N0003 and F0017. Intermountable with Patterns 9522 N0003 and F0012.

2 Pattern 602 - Illustration

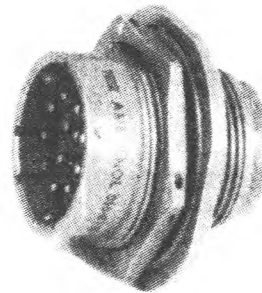
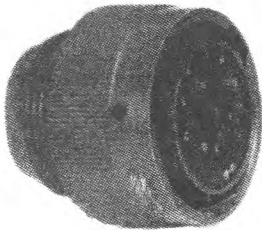

2.1 Characteristics

2.1.1	Environmental category	65/200/56
2.1.2	Low air pressure severity	44 mbars
2.1.3	Number of contacts	2, 3, 4, 5, 6, 8, 10, 11, 12, 15, 16, 18, 19, 21, 23, 26, 31, 32, 36, 39, 41, 55 and 61
2.1.4	Contact termination style	Solder or crimp
2.1.5	Maximum current rating per individual contact	Not stated
2.1.6	Contact finish	Gold Plated

DEF STAN 59-35 (PART 0)/3

SECTION 2

ANNEX A (CONTD)

- | | | |
|---------------|-------------------------------|--|
| 2.1.7 | dc or ac peak Working voltage | Not stated |
| 2.1.8 | Polarization | By housing keys and keyways and insert orientation |
| 2.1.9 | Sealing | Nonsealed, barrier sealed or hermetically sealed types available |
| 2.1.10 | Housing material | Aluminium alloy or stainless steel for hermetically sealed types |
| 2.1.11 | Housing finish | Olive drab chromate conversion over cadmium plate |

3 APPLICATION - TYPICAL

- 3.1** General purpose avionics and airframe fit.
- 3.2** Suitable for cable to panel connections in an exposed environment.
- 3.3** Quick connect/disconnect requirements.
- 3.4** Available with grounding springs for RFI suppression.

4 SPECIFICATION

Connectors pattern number CECC 75-201 XXX meet the requirements of the following specifications.

CECC 75-201 XXX

5 RELATED DOCUMENTS

BS 9520

BS 9522

Interim Def Stan 59-56 (Parts 1 and 2)

Defence Standard Guide Sheet A/017

Connectors Electrical, Circular, MOD Pattern Number 100

1 Description

A multicontact circular connector with quick coarse thread coupling and butting type non-removable solder contact.

2 Pattern 100 - Illustration

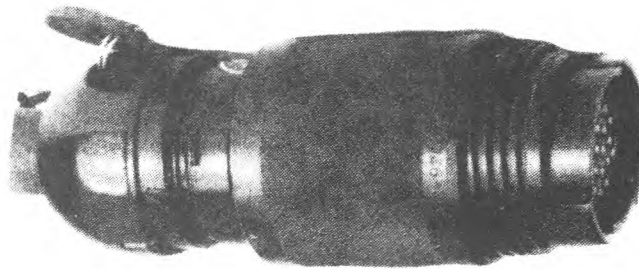

2.1 Characteristics

2.1.1 Climatic category	20/55/56
2.1.2 Low air pressure severity	N/A
2.1.3 Number of contacts	20
2.1.4 Contact termination style	Solder
2.1.5 Maximum current rating per individual contact at 50°C	1 amp
2.1.6 Contact finish	Gold plated
2.1.7 dc or ac peak Working voltage at sea level	250
2.1.8 Polarization	Positive shell hermaphrodite
2.1.9 Sealing	Barrier sealed

Issued January 1990

DEF STAN 59-35 (PART 0)/3
SECTION 2
ANNEX A (CONCLD)

- | | | |
|---------------|------------------|-----------------------|
| 2.1.10 | Housing material | Brass |
| 2.1.11 | Housing finish | Black stove enamelled |

3 Application - Typical

Field telephones.

4 Specification

Def Stan 59-35 (Part 1) Section 14

5 Related Documents

QSTAG 228

Section Three. Connectors Electrical, Rectangular

1 Scope

This Section describes various rectangular connectors which are of the multicontact type.

2 Types of Latching/Locking

2.1 Direct rack and panel ie no discrete locking. Engaging and locking of the connector is normally made by rack assembly.

2.2 Screw locks. These may incorporate jacking devices which will engage and separate the connectors.

2.3 Slide/clip locks. Locking device with sliding or clip action, maintaining engagement of connector.

2.4 Quarter turn lock. Locking device operated by rotary action to maintain engagement.

3 Connector Body

3.1 For the definition see section one, **3.2.5.** In addition the following is applicable:

(a) The contact arrangement refers to a standard configuration and does not necessarily relate to the number of contacts within the housing size, (see table B).

4 Contacts

4.1 Crimp contacts used in different applications have a size designation related to conductor wire size as follows:

<u>Contact size</u>	<u>Conductor size</u>	<u>Circular MIL Area (CMA)</u> (see Note 2)
22D	22, 24, 26 and 28	633, 434, 244 and 169
20	20, 22 and 24	1178, 633 and 434
16	16, 18 and 20	2650, 1841 and 1178
12	12 and 14	5966 and 3305
8	8	16597

NOTE 1: Letter D indicates contact barrel is modified. High density contact arrangements are defined as having individual contact centre line spacing of less than 2.5 mm.

NOTE 2: A circular mil is the area of 1 mil diameter where 1 mil = 0.001 in = 0.0254 mm. The circular mil area is calculated using the formula d^2n where:

d is the nominal diameter of each individual strand (in mils)
n is the number of individual strands in the conductor.

TABLE B-1
 SELECTION CHART FOR CONNECTORS ELECTRICAL, RECTANGULAR (INCLUDING RACK AND PANEL STYLES
 WITH INTEGRAL METAL SHELL)

Typical Application	Pattern Numbers	MOD Pattern Numbers	Notes	Connectors Electrical						Contacts						Defence Standard Number	Guide Sheet Reference							
				Latching Locking				Housing Material	Environment		Terminations		Finish	Shape	Current Rating Amps			Qty						
				Rack and Panel	Screw Lock	Turn Lock	Slide/Clip	Other	Metal Moulded Bodies	Sealed Environment Resistant	Climatic Category	Solder	Crimp	Wire Wrap	Gold			Silver	Other	Circular	Other	Maximum for Largest Contact	Minimum	Maximum
Interchassis Connections	9523 F0002																						B/001	
	9523 F0009		Filter Version of 9523 F0013																				R/002	
Interchassis Connections	9523 F0013	110	Derived MIL-C-24308																				59-35(Pt 3) Sect 12	B/003
Interchassis Connections	9523 F0019																						B/004	
	9524 F0003																						B/005	
	9524 F0005		Derived MIL-C-28748																				B/006	
	9524 F0006																						B/007	
	9524 F0007																						B/008	
	9524 F0011		Derived MIL-C-85028																				B/009	
	9524 F0013																						B/010	

NOTE: P is abbreviation for Power Contacts
 F is abbreviation for Filter Contacts

TABLE B-2
CONNECTORS, ELECTRICAL, RECTANGULAR

CROSS REFERENCE OF CONTACTS/CONTACT ARRANGEMENTS

TOTAL No OF CONTACTS	LF CONTACT SIZE	CONTACT AVAILABILITY				CONNECTORS ELECTRICAL, RECTANGULAR									
		LF	COAX	FILTER	FIBRE OPTIC	PATTERN NUMBERS									
						9523 F0002	9523 F0009	9523 F0013	9523 F0019	9524 F0003	9524 F0005	9524 F0006	9524 F0007	9524 F0011	9524 F0013
1 to 30		X										X			
9	20	X		X			X								
	20	X				X		X							X
10	16	X								X	X				
	22	X													
14	20	X		X			X								
	20	X				X		X							
20	16	X	X			X				X				X	X
		X							X		X				
21		X				X			X	X					X
25	20	X		X			X								
	20	X				X		X							
31		X				X				X					X
	16	X				X				X		X			X
36	20	X		X			X								
	20	X				X		X							
38	22	X				X				X			X		X
	40	X							X						
50	20	X						X	X						
		X				X				X					X
52	16	X	X							X				X	
	16	X									X				
58	22	X											X		
80	16	X	X											X	
	16	X								X					
88	22	X											X		
104	16	X	X											X	
	16	X								X					
108	22	X											X		
132	20	X											X		
158	16	X	X											X	
	16	X								X					
212	16	X	X											X	
	16	X								X					
244	22	X											X		

Def Stan Guide Sheets for Connectors Electrical, Rectangular

B.1 This Annex contains Guide Sheets for connectors electrical, rectangular, for dc and low frequency application for Ministry of Defence use.

B.2 Defence Standard Guide Sheets give a summary of some technical information which will enable designers or users to determine whether or not the candidate connector patterns might be suitable to meet the requirement for a particular application. Final selection should only be made after full consideration of any specific Service requirements and all the relevant features and performance parameters of the candidate patterns. This will require study and definitive interpretation of the relevant detail specifications. Attention should also be given to the NOTE on page 2 of this Standard.

B.3 Tabulated below is a list of individual Guide Sheets which have been prepared for connectors electrical, rectangular, together with Standards related to this guide.

Guide Sheet Reference	BS Pattern Number	Def Stan 59-35 Reference	MOD Pattern Number	Page Number
B/001	9523 F0002	PART 3 SECT 12	110	B-2
B/002	9523 F0009			B-4
B/003	9523 F0013			B-6
B/004	9523 F0019			B-8
B/005	9524 F0003			B-10
B/006	9524 F0005			B-12
B/007	9524 F0006			B-14
B/008	9524 F0007			B-16
B/009	9524 F0011			B-18
B/010	9524 F0013			B-20

B.4 If any difficulties arise from the information contained in the Guide Sheets, then clarification should be sought from the Master Specification Officer (MSO) who is the consulting authority for Connectors, electrical on behalf of the Ministry of Defence. The MSO may be contacted at the following address:

Procurement Executive
 Ministry of Defence
 Electronics Components Group (RSRE)
 Empress State Building
 Lillie Road
 Fulham
 LONDON SW6 1TR

Defence Standard Guide Sheet B/001

Connectors Electrical, Rectangular, Pattern Number 9523 F0002

1 Description

Multi-contact, rectangular connectors, environment resistant non-barrier sealed, with trapezoidal metal housings (shells), non-removable crimp contacts which are factory terminated to conductors. Available in fixed or floating bush mounting styles.

2 Pattern 9523 F0002 - Illustration

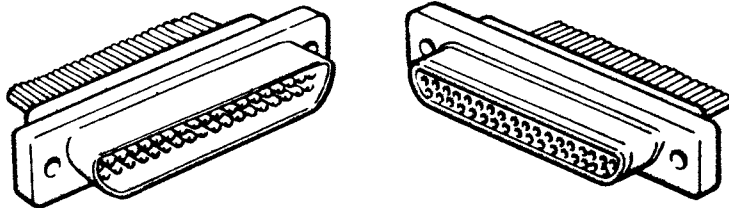

2.1 Characteristics

2.1.1	Environmental category	55/125/56
2.1.2	Low air pressure severity	44 mbars
2.1.3	Number of contacts	9, 15, 21, 25, 31, 37, 51
2.1.4	Contact termination style	Crimp, non-removable
2.1.5	Maximum current rating at 85°C:	
2.1.5.1	Per individual contact in isolation	3 A
2.1.5.2	Per contact through all contacts simultaneously	1.8 A
2.1.6	Contact finish	Gold plated

2.1.7 dc or ac peak Working voltage at sea level	250 volts
2.1.8 Polarization	Trapezoidal housing
2.1.9 Sealing	Environment resistant, Non-barrier sealed
2.1.10 Housing material	Glass filled thermosetting
2.1.11 Housing finish	Yellow, chromate conversion over cadmium plate

3 Specification

BS 9523 F0002

4 Related Documents

BS 9520

BS 9523

Defence Standard Guide Sheet B/002

Connectors Electrical, Rectangular, Pattern Number 9523 F0009

1 Description

Multi-contact, rack and panel connectors with fixed solder bucket and/or through board (pintail) termination filter type male contact for dc and ac applications. Rack and panel applications with filter type male contacts.

2 Pattern 9523 F0009 - Illustration

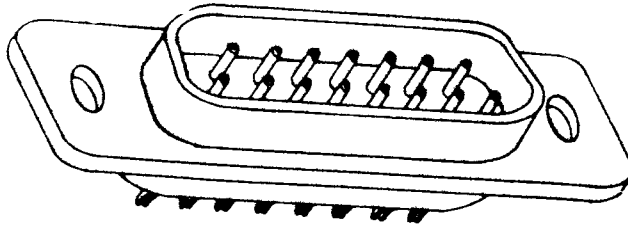

2.1 Characteristics

2.1.1	Environmental category	55/125/56
2.1.2	Low air pressure severity	44 mbars
2.1.3	Number of contacts	9, 15, 25, 37
2.1.4	Contact termination style	Solder/pintail
2.1.5	Maximum current rating at 85°C:	
2.1.5.1	Per individual contact in isolation	7.5 amps (power) 3 amps (filter)
2.1.5.2	Per contact through all contacts simultaneously	5 amps (power) 3 amps (filter)
2.1.6	Contact finish	Gold plated

2.1.7	dc or ac peak Working voltage at sea level	500 volts (power) 100 (filter) or 200 (filter pi)
2.1.8	Polarization	180° trapezoidal
2.1.9	Sealing	Non sealed
2.1.10	Housing material	Aluminium alloy
2.11	Housing finish	Clear Chromate finish over cadmium plate

3 Specification

BS 9523 F0009

4 Related Documents

BS 9520

BS 9523

Defence Standard Guide Sheet B/003

Connectors Electrical, Rectangular, Pattern Number 9523 F0013

(Formerly MOD Pattern Number 110)

1 Description

Multi-contact unsealed connector, with trapezoidal metal housing (shells) and non removable contacts with solder terminations, rack and panel applications.

2 Pattern 9523 F0013 - Illustration

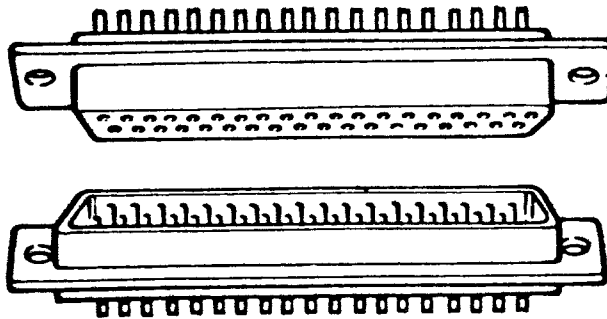

2.1 Characteristics

2.1.1	Environmental category	55/125/56
2.1.2	Low air pressure severity	300 mbars
2.1.3	Number of contacts	9, 15, 25, 37, 50
2.1.4	Contact termination style	Solder
2.1.5	Maximum current rating at 85°C:	
2.1.5.1	Per individual contact in isolation	7.5 amps
2.1.5.2	Per contact through all contacts simultaneously	5 amps
2.1.6	Contact finish	Gold plated

2.1.7	dc or ac peak Working voltage at sea level	750 volts
2.1.8	Polarization	180° trapezoidal
2.1.9	Sealing	Non sealed
2.1.10	Housing material	Steel
2.11	Housing finish	Yellow chromate conversion over cadmium plate

3 Specification

BS 9523 F0013

4 Related Documents

BS 9520

BS 9523

Defence Standard Guide Sheet B/004

Connectors Electrical, Rectangular, Pattern Number 9523 F0019

1 Description

Multi-contact, environment resistant (non-barrier sealed), with plated non-ferrous metal housings (shells) and jackscrew couplings. Removable/ Interchangeable insulators, which contains removable crimp or non-removable wire-wrap and through-board solder terminations. Polarisation by asymmetrical shells and polarizing keys.

2 Pattern 9523 F0019 - Illustration

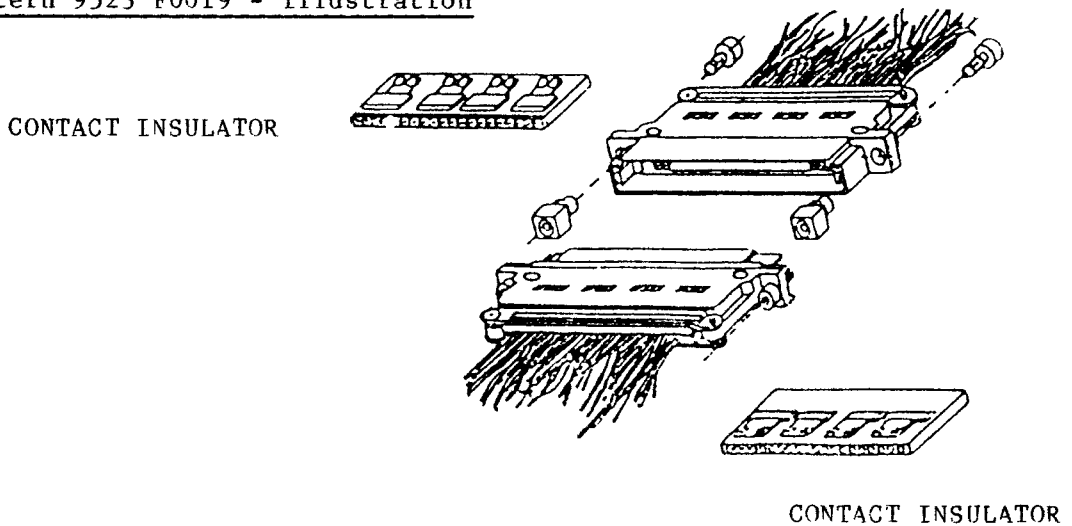

2.1 Characteristics

2.1.1	Environmental category	55/150/21
2.1.2	Low air pressure severity	11 mbars
2.1.3	Number of contacts	10 and 20 per contact row Maximum 20 or 40 contacts per connector size
2.1.4	Contact termination style	Crimp, solderless wrap, solder
2.1.5	Maximum current rating at 85°C:	
2.1.5.1	Per individual contact in isolation	5A
2.1.5.2	Per contact through all contacts simultaneously	3A
2.1.6	Contact finish	Gold plated

2.1.7	dc or ac peak Working voltage at sea level	700 volts
2.1.8	Polarization	Asymmetrical housing and polarising keys
2.1.9	Sealing	Unsealed
2.1.10	Housing material	Non-ferrous metal
2.1.11	Housing finish	Nickel plate

3 Specification

BS 9523 F0019

4 Related Documents

BS 9520

BS 9523

Defence Standard Guide Sheet B/005

Connectors Electrical, Rectangular, Pattern Number 9524 F0003

1 Description

Multi-contact rectangular connectors with trapezoidal housing, and non-removable crimp contacts which are factory terminated to conductors

2 Pattern 9524 F0003 - Illustration

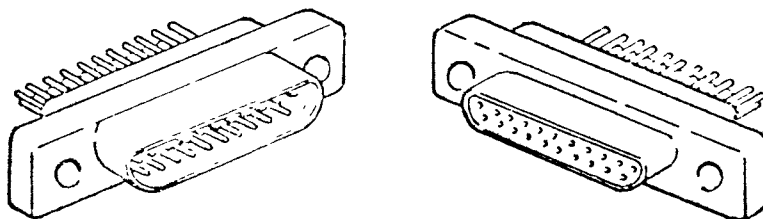

2.1 Characteristics

2.1.1	Environmental category	55/125/56
2.1.2	Low air pressure severity	44 mbars
2.1.3	Number of contacts	9, 15, 21, 25, 31, 37, 51
2.1.4	Contact termination style	Crimp
2.1.5	Maximum current rating at 85°C:	
2.1.5.1	Per individual contact in isolation	3A
2.1.5.2	Per contact through all contacts simultaneously	1.8A
2.1.6	Contact finish	Gold plated

2.1.7	dc or ac peak Working voltage at sea level	250 volts
2.1.8	Polarization	Trapezoidal housing
2.1.9	Sealing	Unsealed
2.1.10	Housing material	Glass filled thermosetting
2.1.11	Housing finish	Natural

3 Specification

BS 9524 F0003

4 Related Documents

BS 9520

BS 9524

Defence Standard Guide Sheet B/006

Connectors Electrical, Rectangular, Pattern Number 9524 F0005

1 Description

Multi-contact unsealed rectangular connectors with moulded bodies and recessed or extended centre jackscrews or guide pin couplings, intended for rack and panel, inter chassis and other chassis to cable connectors.

2 Pattern 9524 F0005 - Illustration

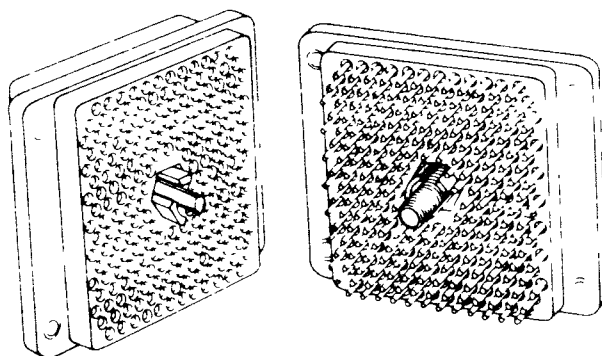

2.1 Characteristics

2.1.1	Environmental category	55/125/56
2.1.2	Low air pressure severity	300 mbars
2.1.3	Number of contacts	10, 20, 36, 52, 80, 104, 158, 212
2.1.4	Contact termination style	Crimp
2.1.5	Maximum current rating:	
2.1.5.1	Per individual contact in isolation at 125°C	13 amps
2.1.5.2	Per contact through all contacts simultaneously at 85°C	13 amps
2.1.6	Contact finish	Gold plated

2.1.7	dc or ac peak Working voltage at sea level	700 volts
2.1.8	Polarization	Centre boss (54 polarizations)
2.1.9	Sealing	Nonsealed
2.1.10	Housing material	Hard thermosetting plastic
2.1.11	Housing finish	Natural

3 Specification

BS 9524 F0005

4 Related Documents

BS 9520

BS 9524

Defence Standard Guide Sheet B/007

Connectors Electrical, Rectangular, Pattern Number 9524 F0006

1 Description

Multi-contact single-row moulded rectangular connectors, unsealed with non-removable crimp contacts which are factory terminated to conductors. Suitable for mounting with adhesive (eg epoxy).

2 Pattern 9524 F0006 - Illustration

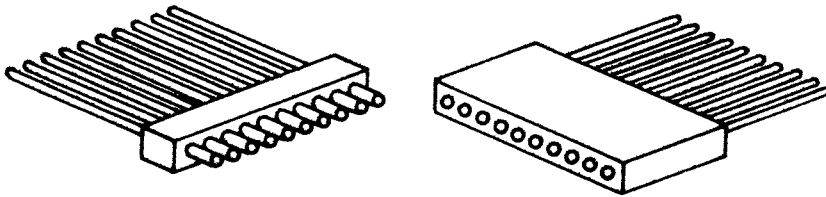

2.1 Characteristics

2.1.1	Environmental category	55/125/56
2.1.2	Low air pressure severity	44 mbars
2.1.3	Number of contacts	1 to 30
2.1.4	Contact termination style	Crimp
2.1.5	Maximum current rating at 85°C:	
2.1.5.1	Per individual contact in isolation	3A
2.1.5.2	Per contact through all contacts simultaneously	1.8A
2.1.6	Contact finish	Gold plated

2.1.7	dc or ac peak Working voltage at sea level	225 volts
2.1.8	Polarization	Guide posts (in lieu of socket contacts)
2.1.9	Sealing	Unsealed
2.1.10	Housing material	Glass filled diallylphthalate
2.1.11	Housing finish	Natural

3 Specification

BS 9524 F0006

4 Related Documents

BS 9520

BS 9524

Defence Standard Guide Sheet B/008

Connectors Electrical, Rectangular, Pattern Number 9524 F0007

1 Description

Multi-contact unsealed connector with moulded bodies and recessed or extended centre jackscrews or guide pin coupling. Intended for rack and panel, inter chassis and other chassis to cable connectors.

2 Pattern 9524 F0007 - Illustration

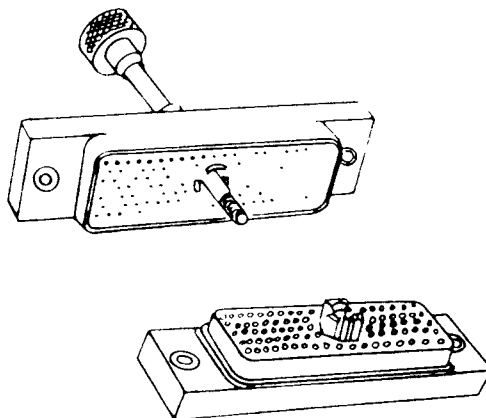

2.1 Characteristics

2.1	Environmental category	55/125/56
2.1.2	Low air pressure severity	44 mbars
2.1.3	Number of contacts	14, 38, 58, 88, 108, 132, 244
2.1.4	Contact termination style	Crimp
2.1.5	Maximum current rating:	
2.1.5.1	Per individual contact in isolation at 85°C	3 amps
2.1.5.2	Per contact through all contacts simultaneously at 85°C	3 amps
2.1.6	Contact finish	Gold plated

2.1.7	dc or ac peak Working voltage at sea level	520 volts
2.1.8	Polarization	Centre boss (54 polarizations)
2.1.9	Sealing	Non sealed
2.1.10	Housing material	Hard thermosetting plastic
2.1.11	Housing finish	Natural

3 Specification

BS 9524 F0007

4 Related Documents

BS 9520

BS 9524

Defence Standard Guide Sheet B/009

Connectors Electrical, Rectangular, Pattern Number 9524 F0011

1 Description

Multi-contact sealed environmental connectors with moulded bodies and recessed or extended centre jackscrews or guide pins couplings. Intended for rack and panel, inter chassis and other chassis to cable connections.

2 Pattern 9524 F0011 - Illustration

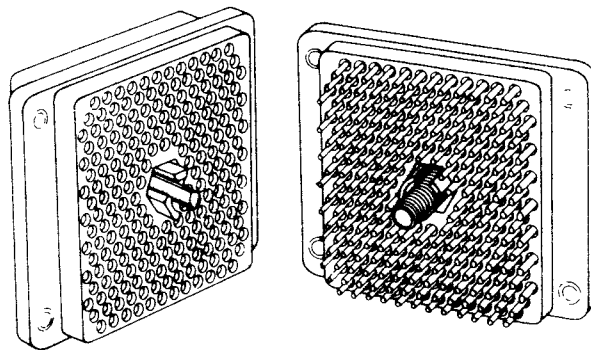

2.1 Characteristics

2.1.1	Environmental category	55/125/56
2.1.2	Low air pressure severity	44 mbars
2.1.3	Number of contacts	20, 52, 80, 104, 158, 212
2.1.4	Contact termination style	Crimp
2.1.5	Maximum current rating:	
2.1.5.1	Per individual contact in isolation at 125°C	1 amp (coaxial contact) 13 amps (power contact size 16)
2.1.5.2	Per contact through all contacts simultaneously at 85°C	13 amp Insert arrangement 20) 9.75 amp Insert arrangement 52) 7.75 amp Insert arrangement 80) Power 7.15 amp Insert arrangement 104) Contact 6.25 amp Insert arrangement 158) (size 16) 5.5 amp Insert arrangement 212) 1 amp coaxial contact
2.1.6	Contact finish	Gold plated

2.1.7	dc or ac peak Working voltage at sea level	1000 volts power contacts 250 volts coaxial contacts
2.1.8	Polarization	Centre boss (54 polarizations)
2.1.9	Sealing	Contacts are individual sealed
2.1.10	Housing material	Hard thermosetting plastic
2.1.11	Housing finish	Natural

3 Specification

BS 9524 F0011

4 Related Documents

BS 9520

BS 9524

Defence Standard Guide Sheet B/010

Connectors Electrical, Rectangular, Pattern Number 9524 F0013

1 Description

Multi-contact moulded rectangular connectors with trapezoidal housing, and non-removable crimp contacts which are factory terminated to conductors.

2 Pattern 9524 F0013 - Illustration

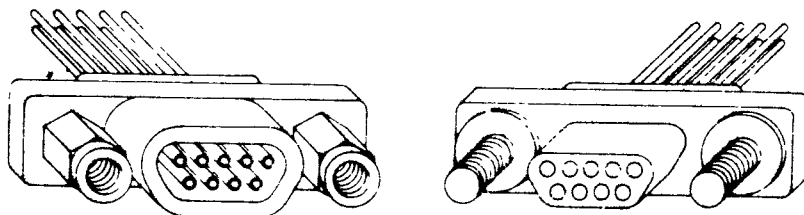

2.1 Characteristics

2.1	Environmental category	55/125/56
2.1.2	Low air pressure severity	44 mbars
2.1.3	Number of contacts	9, 15, 21, 25, 31, 37, 51
2.1.4	Contact termination style	Crimp
2.1.5	Maximum current rating at 85°C:	
2.1.5.1	Per individual contact in isolation	3A
2.1.5.2	Per contact through all contacts simultaneously	1.8A
2.1.6	Contact finish	Gold plated

2.1.7	dc or ac peak Working voltage at sea level	250 volts
2.1.8	Polarization	Trapezoidal housing
2.1.9	Sealing	Unsealed
2.1.10	Housing material	Glass filled polyester
2.1.11	Housing finish	Natural

3 Specification

BS 9524 F0013

4 Related Documents

BS 9520

BS 9524

Section Four. Connectors Electrical, Two-Part Printed Board Connectors

1 Scope

This Section describes various two-part printed board connectors which are of the multicontact type.

2 Types of Latching/Locking

2.1 Rack and panel ie no discrete locking. Engaging and locking of the connector is normally made by rack assembly.

2.2 Screw lock. These may incorporate jacking devices which will engage and separate the connectors.

2.3 Latch lock. Locking resilient tooth, which engages with a corresponding recess to maintain engagement.

2.4 Quarter turn lock. Locking device operated by rotary action to maintain engagement.

3 Connector Body

Moulded body.

4 Contacts

Contacts may be machined, formed or pressed with termination suitable for solder or crimp for wire, on board/through board solderless wrap, force fit to board and through board termination for rear plug up.

TABLE C-1
SELECTION CHART FOR CONNECTORS ELECTRICAL, TWO-PART PRINTED BOARD

TYPICAL APPLICATION	PATTERN NUMBERS	MOD PATTERN NUMBERS	NOTES	CONTACTS							CLIMATIC CATEGORY	DEFENCE STANDARD NUMBER	GUIDE SHEETS REFERENCE	
				PITCH mm	NO WAYS	TERMINATIONS				FORCE FIT				CURRENT RATING AMPS
						CRIMP	SW	SOLDER	OTHER					
	9525 N0001	127	Derived from NFC 93424 model HE801	2.54	17 to 120	X	X	X			1.5	55/125/56	C-001	
	9525 F0003				1			X			7.0	55/125/56	C-002	
	9525 F0004	-	Derived from VG 95324 Din 41612	2.54	16 to 96		X	X			1.5	55/125/56	C-003	
Individual through board	9525 F0005							X			3, 5 and 10	55/125/56	C-004	
	9525 F0012		Derived NFC 93 424 HF S07 with rf coaxial contacts	2.54							1.5 rf 0.5	55/125/56	C-005	
	9525 F0016			2.54	48 to 160	X	X	X			1.5	55/125/56	C-006	
Reverse mounting version of F0004 i.e. male contact for mother board and female for daughter board	9525 F0017			2.54	32 to 96		X	X			1.5	55/125/56	C-007	
	9525 F0019		Derivative of Din 41612 with large contact cavities for power and coaxial contacts	2.54 Basic	8 + 8 to 78 + 2		X	X			1.5	55/125/56	C-008	
	9525 F0027			2.54	0 + 7 53 + 3	X	X	X			1.5 LF 0.5 coax 15.0 hp	55/125/56	C-009	
	9525 F0031		Derived DIN 41612 double Eurocard	2.54	192		X	X				55/125/56	C-010	
	9525 F0033			2.0	2 to 34	X		X			1.75	55/125/56	C-011	
	9525 F0036				20, 34, 40				X		1.75 2.0 3.0	55/105/21	C-012	
Rear plug in Interface system for use with F0004, F0013 and F0017	9525 F0042			2.54	96						2	55/125/56	C-013	
	9525 F0043			2.54	57, 76, 152,			X			3.0	55/125/56	C-014	

4-2

TABLE C-2

CONNECTORS ELECTRICAL, TWO-PART PRINTED BOARD
 CROSS REFERENCE OF CONTACTS/CONTACT ARRANGEMENTS

CONTACT ARRANGEMENT			CONNECTORS ELECTRICAL, TWO-PART PRINTED BOARD													
			PATTERN NUMBERS													
LF CONTACTS	HIGH POWER/ COAX	FIBRE OPTIC	9525 N0001	9525 F0003	9525 F0004	9525 F0005	9525 F0012	9525 F0016	9525 F0017	9525 F0019	9525 F0027	9525 F0031	9525 F0033	9525 F0036	9525 F0042	9525 F0043
1				x		x										
2																
3														x		
4														x		
5														x		
6														x		
7														x		
8														x		
10														x		
12														x		
14														x		
16														x		
17			x											x		
18														x	x	
20														x		
26														x	x	
29			x												x	
32					x				x	x	x					
33			x													
34																x
40																x
41			x													
48					x			x	x	x	x					
53			x													
57																
64					x				x	x	x					
65			x													
72			x													
76																
84			x													
96			x		x				x	x	x				x	
98								x								

4-3

TABLE C-2 (Continued)

CONTACT ARRANGEMENT			CONNECTORS ELECTRICAL, TWO-PART PRINTED BOARD													
LF CONTACTS	HIGH POWER/COAX	FIBRE OPTIC	PATTERN NUMBERS													
			9525 N0001	9525 F0003	9525 F0004	9525 F0005	9525 F0012	9525 F0016	9525 F0017	9525 F0019	9525 F0027	9525 F0031	9525 F0033	9525 F0036	9525 F0042	9525 F0043
119								x								
120			x													
128													x			
152																x
160								x								
192													x			
228																x
5	3						x					x				
17	3						x					x				
29	3						x					x				
41	3						x					x				
53	3						x					x				
5	6						x					x				
17	6						x					x				
29	6						x					x				
41	6						x					x				
7							x					x				

4-4

Def Stan Guide Sheets for Connectors Electrical, Two-Part Printed Board

C.1 This Annex contains Guide Sheets for connectors electrical, two-part printed board, for dc and low frequency application for Ministry of Defence use.

C.2 Defence Standard Guide Sheets give a summary of some technical information which will enable designers or users to determine whether or not the candidate connector patterns might be suitable to meet the requirement for a particular application. Final selection should only be made after full consideration of any specific Service requirements and all the relevant features and performance parameters of the candidate patterns. This will require study and definitive interpretation of the relevant detail specifications. Attention should also be given to the NOTE on page 2 of this Standard.

C.3 Tabulated below is a list of individual Guide Sheets which have been prepared for connectors electrical, two-part printed board, together with Standards related to this guide.

Guide Sheet Reference	BS Pattern Number	Def Stan 59-35 Reference	MOD Pattern Number	Page Number
C/001	9525 N0001	-	127	C-2
C/002	9525 F0003	-	-	C-4
C/003	9525 F0004	-	-	C-5
C/004	9525 F0005	-	-	C-8
C/005	9525 F0012	-	-	C-10
C/006	9525 F0016	-	-	C-12
C/007	9525 F0017	-	-	C-14
C/008	9525 F0019	-	-	C-16
C/009	9525 F0027	-	-	C-18
C/010	9525 F0031	-	-	C-20
C/011	9525 F0033	-	-	C-22
C/012	9525 F0036	-	-	C-24
C/013	9525 F0042	-	-	C-26
C/014	9525 F0043	-	-	C-28

C.4 If any difficulties arise from the information contained in the Guide Sheets, then clarification should be sought from the Master Specification Officer (MSO) who is the consulting authority for Connectors, electrical on behalf of the Ministry of Defence. The MSO may be contacted at the following address:

Procurement Executive
 Ministry of Defence
 Electronics Component Group (RSRE)
 Empress State Building
 Lillie Road
 Fulham
 LONDON SW6 1TR

Defence Standard Guide Sheet C/001

Connectors Electrical, Two-Part Printed Board, Pattern Number 9525 N0001

1 Description

Multi-contact 2 part connector, unsealed, environment resistant with parallel or perpendicular mounting for printed boards. Two rows of contacts 2.54 mm pitch, staggered.

2 Pattern 9525 N0001 - Illustration

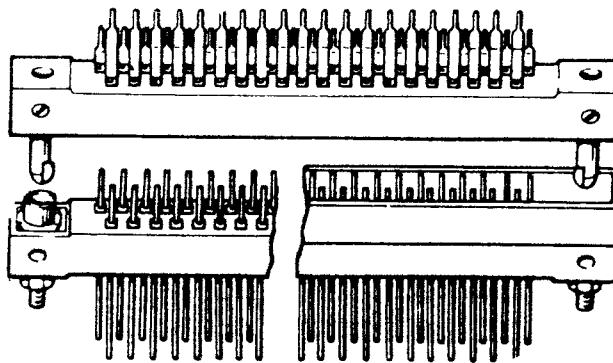

2.1 Characteristics

2.1.1	Environmental category	55/125/56
2.1.2	Low air pressure severity	300 mbars
2.1.3	Number of contacts	17, 29, 33, 41, 53, 65, 72, 84, 96, 120
2.1.4	Contact termination style	Crimp, solder, solderless wrap
2.1.5	Maximum current rating at 85°C:	
2.1.5.1	Per individual contact in isolation	1.5 amps
2.1.5.2	Per contact through all simultaneously	1.0 amps 3.0 amps (at 25°C)
2.1.6	Contact finish	Gold plated

2.1.7	dc or ac peak Working voltage at sea level	170 volts
2.1.8	Polarization	Key/keyway
2.1.9	Sealing	Unsealed
2.1.10	Housing material	Hard thermosetting plastic
2.1.11	Housing finish	Natural

3 Specification

BS 9525 N0001

4 Related Documents

BS 9520

BS 9525

Defence Standard Guide Sheet C/002

Connectors Electrical, Two-Part Printed Board, Pattern Number 9525 F0003

1 Description

Miniature snap-on free connector with single female contact for use with flying leads, and ball-ended fixed test point with solder termination in lead-through and stand-off styles for printed board mounting. Fixed test point also available for metal chassis mounting.

2 Pattern 9525 F0003 - Illustration

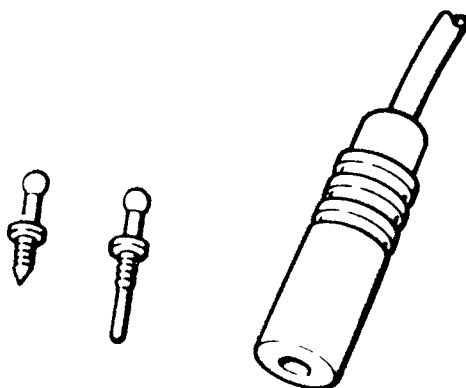

2.1 Characteristics

2.1.1	Environmental category	55/125/56
2.1.2	Low air pressure severity	N/A
2.1.3	Number of contacts	1
2.1.4	Contact termination style	Solder
2.1.5	Maximum current rating at 85°C:	
2.1.5.1	Per individual contact in isolation	7 amps
2.1.5.2	Per contact through all contacts simultaneously	N/A
2.1.6	Contact finish	Silver plated female contacts palladium plated male contacts

2.1.7	dc or ac peak Working voltage at sea level	1000 volts
2.1.8	Polarization	N/A
2.1.9	Sealing	Unsealed
2.1.10	Housing material	PTFE
2.1.11	Housing finish	Coloured black, brown, red, orange, yellow, green, blue, violet, grey, white or pink

3 Specification

BS 9525 F0003

4 Related Documents

BS 9520

BS 9525

Defence Standard Guide Sheet C/003

Connectors Electrical, Two-Part Printed Board, Pattern Number 9525 F0004

1 Description

Multi-contact 2 part rectangular connector, unsealed with parallel or perpendicular mounting for single or doubled sided printed boards.
Pitch 2.54 mm.

2 Pattern 9525 F0004 - Illustration

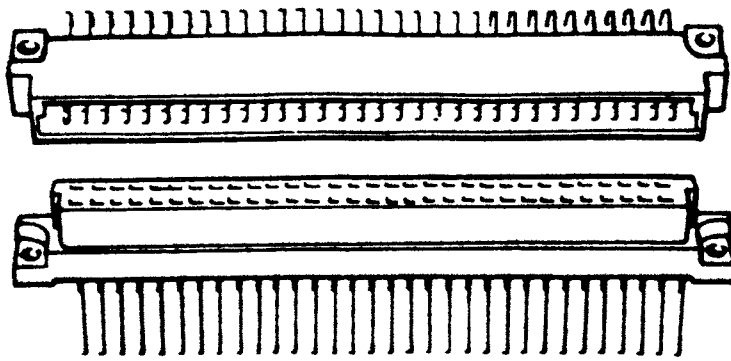

2.1 Characteristics

2.1.1	Environmental category	55/125/56
2.1.2	Low air pressure severity	300 mbars
2.1.3	Number of contacts	32, 48, 64, 96
2.1.4	Contact termination style	Solder, solderless wrap
2.1.5	Maximum current rating at 85°C:	
2.1.5.1	Per individual contact in isolation	1.5 amps
2.1.5.2	Per contact through all contacts simultaneously	1.0 amps
2.1.6	Contact finish	Gold Plated

2.1.7	dc or ac peak Working voltage at sea level	350 volts
2.1.8	Polarization	Asymmetrical housing
2.1.9	Sealing	Unsealed
2.1.10	Housing material	Hard thermosetting plastic
2.1.11	Housing finish	Natural

3 Specification

BS 9525 F0004

4 Related Documents

BS 9520
BS 9525
DIN 41612

Defence Standard Guide Sheet C/004

Connectors Electrical, Two-Part Printed Board, Pattern Number 9525 F0005

1 Description

Miniature, single pole connector for printed boards.

2 Pattern 9525 F0005 - Illustration

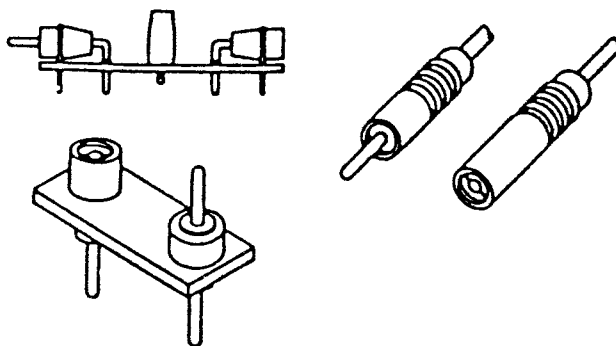

2.1 Characteristics

2.1.1	Environmental category	55/125/56																								
2.1.2	Low air pressure severity	N/A																								
2.1.3	Number of contacts	Single pole																								
2.1.4	Contact termination style	Solder																								
2.1.5	Maximum current rating per individual contact at 50°C:	<table border="0"> <thead> <tr> <th style="text-align: left;">Contact size</th> <th style="text-align: left;">Contact diameter</th> <th style="text-align: left;"></th> </tr> </thead> <tbody> <tr> <td>6</td> <td>0.9 mm (0.030")</td> <td>3 amps</td> </tr> <tr> <td>9</td> <td>1.0 mm (0.040")</td> <td>3 amps</td> </tr> <tr> <td>12</td> <td>1.3 mm (0.050")</td> <td>3 amps</td> </tr> <tr> <td>15</td> <td>1.5 mm (0.060")</td> <td>3 amps</td> </tr> <tr> <td>18</td> <td>2.0 mm</td> <td>5 amps</td> </tr> <tr> <td>21</td> <td>2.5 mm (0.100")</td> <td>5 amps</td> </tr> <tr> <td>24</td> <td>4.0 mm</td> <td>10 amps</td> </tr> </tbody> </table>	Contact size	Contact diameter		6	0.9 mm (0.030")	3 amps	9	1.0 mm (0.040")	3 amps	12	1.3 mm (0.050")	3 amps	15	1.5 mm (0.060")	3 amps	18	2.0 mm	5 amps	21	2.5 mm (0.100")	5 amps	24	4.0 mm	10 amps
Contact size	Contact diameter																									
6	0.9 mm (0.030")	3 amps																								
9	1.0 mm (0.040")	3 amps																								
12	1.3 mm (0.050")	3 amps																								
15	1.5 mm (0.060")	3 amps																								
18	2.0 mm	5 amps																								
21	2.5 mm (0.100")	5 amps																								
24	4.0 mm	10 amps																								
2.1.6	Contact finish	Male - Gold plated Female - Silver plated																								

2.1.7	dc or ac peak Working voltage at sea level	Contact size: 6 2 kV 9 2 kV 12 2 kV 15 2 kV 18 2 kV 21 4 kV 24 4 kV
2.1.8	Polarization	N/A
2.1.9	Sealing	Non sealed
2.1.10	Housing material	PTFE
2.1.11	Housing finish	Natural

3 Specification

BS 9525 F0005

4 Related Documents

BS 9520

BS 9525

Defence Standard Guide Sheet C/005

Connectors Electrical, Two-Part Printed Board, Pattern Number 9525 F0012

1 Description

Multi-contact 2 part connector unsealed, environment resistant with parallel or perpendicular mounting.

2 Pattern 9525 F0012 - Illustration

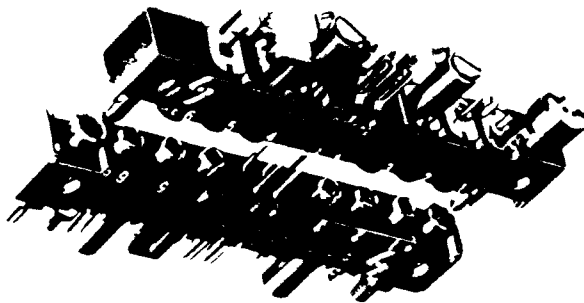

2.1 Characteristics

2.1.1	Environmental category	55/125/56
2.1.2	Low air pressure severity	300 mbars
2.1.3	Number of contacts	Coaxial - 3, 3, 3, 3, 3, 6, 6, 6, 6, 0 Lf - 5, 17, 29, 41, 53, 5, 17, 29, 41, 7
2.1.4	Contact termination style	Solderless wrap, crimp, solder
2.1.5	Maximum current rating at 85°C:	
2.1.5.1	Per individual contact in isolation	1.5 amps 0.5 amps rf
2.1.5.2	Per contact through all contacts simultaneously	1.0 amps 3.0 amps (at 25°C)
2.1.6	Contact finish	Gold plated

2.1.7	dc or ac peak Working voltage at sea level	170 volts 150 volts (coaxial)
2.1.8	Polarization	Key/keyways
2.1.9	Sealing	Unsealed
2.1.10	Housing material	Hard thermosetting plastic
2.1.11	Housing finish	Natural

3 Specification

BS 9525 F0012

4 Related Documents

BS 9520

BS 9525

Defence Standard Guide Sheet C/006

Connectors Electrical, Two-Part Printed Board, Pattern Number 9525 F0016

1 Description

Multi-contact, 2 part connector with replaceable contacts arranged in 3 rows on staggered pitch. Male contact connectors are available with and without shrouds. Contacts have crimp, solder for wire, wire-wrap and through-board solder terminations. Available with polarizing guides, non-polarizing guides, jack screws or quarter-turn locking guides.

2 Pattern 9525 F0016 - Illustration

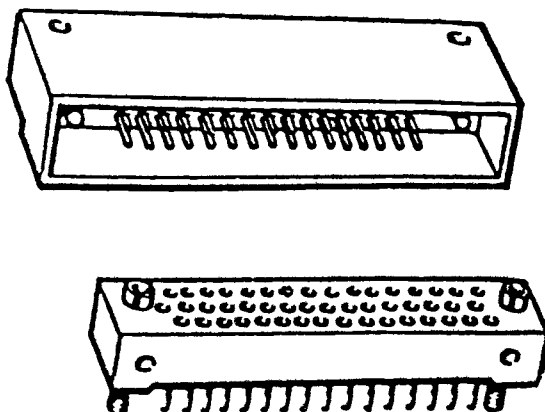

2.1 Characteristics

2.1.1	Environmental category	55/125/56
2.1.2	Low air pressure severity	300 mbar
2.1.3	Number of contacts	48, 98, 119, 160
2.1.4	Contact termination style	Crimp, solder for wire, throughboard solder and solderless wrap
2.1.5	Maximum current rating at 85°C:	
2.1.5.1	Per individual contact in isolation	1.5 amps
2.1.5.2	Per contact through all contacts simultaneously	1 amp 3 amps (at 25°C)
2.1.6	Contact finish	Gold plated

2.1.7	dc or ac peak Working voltage at sea level	170 volts
2.1.8	Polarization	Polarizing guides
2.1.9	Sealing	Unsealed
2.1.10	Housing material	Glass filled diallylphthalate
2.1.11	Housing finish	Natural

3 Specification

BS 9525 F0016

4 Related Documents

BS 9520

BS 9525

Defence Standard Guide Sheet C/007

Connectors Electrical, Two-Part Printed Board, Pattern Number 9525 F0017

1 Description

Multi-contact 2 part connector, unsealed, with parallel or perpendicular mounting for single or double sided printed boards. 2.54 mm contact pitch

2 Pattern 9525 F0017 - Illustration

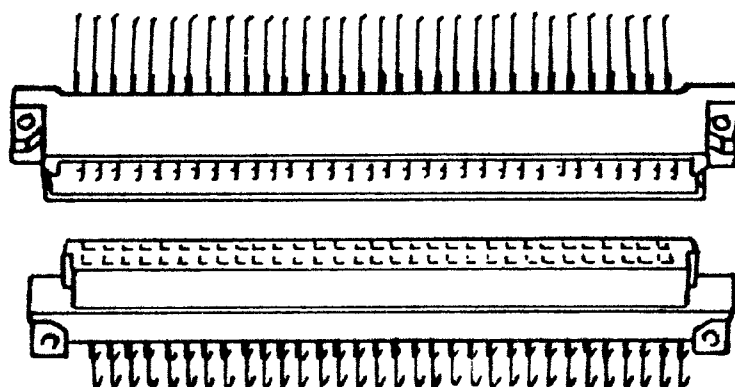

2.1 Characteristics

2.1.1	Environmental category	55/125/56
2.1.2	Low air pressure severity	300 mbars
2.1.3	Number of contacts	32, 48, 64, 96
2.1.4	Contact termination style	Solder, solderless wrap
2.1.5	Maximum current rating at 85°C:	
2.1.5.1	Per individual contact in isolation	1.5 amps
2.1.5.2	Per contact through all contacts simultaneously	1.0 amps
2.1.6	Contact finish	Gold Plated

2.1.7	dc or ac peak Working voltage at sea level	350 volts
2.1.8	Polarization	Asymmetrical housing
2.1.9	Sealing	Unsealed
2.1.10	Housing material	Hard thermoplastic
2.1.11	Housing finish	Natural

3 Specification

BS 9525 F0017

4 Related Documents

BS 9520

BS 9525

DIN 41612 (reverse mounting styles)

Defence Standard Guide Sheet C/008

Connectors Electrical, Two-Part Printed Board, Pattern Number 9525 F0019

1 Description

Multi-contact 2 part rectangular connector, unsealed with parallel or perpendicular mounting for single or double sided printed boards. Pitch 2.54 mm. Connectors are available with LF type contacts and mixed LF and coaxial/high power (hp) type contact arrangements.

2 Pattern 9525 F0019 - Illustration

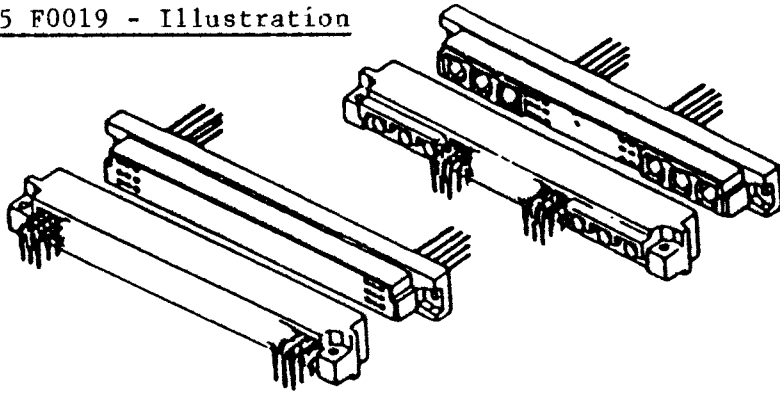

2.1 Characteristics

2.1.1	Environmental category	55/125/56
2.1.2	Low air pressure severity	300 mbars
2.1.3	Number of contacts	32, 48, 64, 96, 78 + 2 coax/hp, 60 + 4 coax/hp, 42 + 6 coax/hp, 24 + 8 coax/hp, 12 + 4 coax/hp, 30 + 2 coax/hp
2.1.4	Contact termination style	Solder, solderless wrap
2.1.5	Maximum current rating at 85°C:	
2.1.5.1	Per individual contact in isolation	1.5 amps (LF contacts) 40 amps size 8 (hp contacts) 20 amps size 12 (hp contacts) 10 amps size 16 (hp contacts)
2.1.5.2	Per contact through a contacts simultaneously	111.0 amps (LF contacts) 25 amps size 8 (hp contacts) 13 amps size 12 (hp contacts) 7 amps size 16 (hp contacts)

2.1.6	Contact finish	Gold plated
2.1.7	dc or ac peak Working voltage at sea level	LF + hp 350 volts Coaxial 250 volts
2.1.8	Polarization	Asymmetrical
2.1.9	Sealing	Unsealed
2.1.10	Housing material	Hard thermosetting plastic
2.1.11	Housing finish	Natural

3 Specification

BS 9525 F0019

4 Related Documents

BS 9520
BS 9525
DIN 41612

Defence Standard Guide Sheet C/009

Connectors Electrical, Two-Part Printed Board, Pattern Number 9525 F0027

1 Description

Multi-contact, 2-part printed board connector with replaceable contacts comprising LF and mixed LF, coaxial and hp arrangements. Polarization by guides or quarter-turn locks, and also available with non-polarizing guides or jack screws. Contact shrouds and covers are available.

2 Pattern 9525 F0027 - Illustration

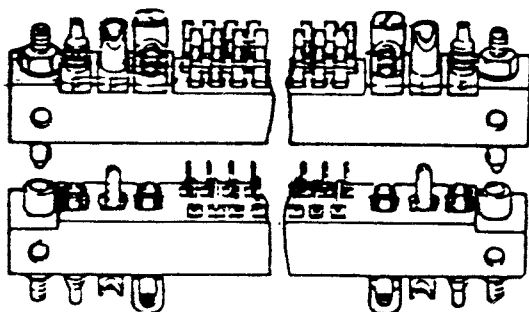

2.1 Characteristics

- | | | |
|----------------|--|---|
| 2.1.1 | Environmental category | 55/125/56 |
| 2.1.2 | Low air pressure severity | 300 mbar |
| 2.1.3 | Number of contacts | 5 + 3 coax/hp, 0 + 7 coax/hp,
5 + 6 coax/hp, 17 + 3 coax/hp,
17 + 6 coax/hp, 29 + 3 coax/hp,
29 + 6 coax/hp, 41 + 3 coax/hp,
41 + 6 coax/hp, 53 + 3 coax/hp |
| 2.1.4 | Contact termination style | Crimp, solder for wire,
through-board, solder and solderless
wrap (LF) Solder, and printed board |
| 2.1.5 | Maximum current rating
at 85°C: | |
| 2.1.5.1 | Per individual contact
in isolation | 1.5 amps (LF)
0.5 amps (Coax)
15.0 amps (hp) |
| 2.1.5.2 | Per contact through all
contacts simultaneously | 1 amp (LF)
10 amps (hp)
3 amps (LF) (at 25°C)
25 amps (hp) (at 25°C) |
| 2.1.6 | Contact finish | Gold plated |

Issued January 1990

DEF STAN 59-35 (PART 0)/3

SECTION 4

ANNEX C (CONTD)

2.1.7	dc or ac peak Working voltage at sea level	170 volts
2.1.8	Polarization	Polarizing guide or quarter-turn locking guides
2.1.9	Sealing	Unsealed
2.1.10	Housing material	Diallylphthalate
2.1.11	Housing finish	Natural

3 Specification

BS 9525 F0027

4 Related Documents

BS 9520

BS 9525

Defence Standard Guide Sheet C/010

Connectors Electrical, Two-Part Printed Board, Pattern Number 9525 F0031

1 Description

Multi-contact 2 part Double Eurocard printed board connector, unsealed with parallel or perpendicular mounting for single or double sided printed boards.

2 Pattern 9525 F0031 - Illustration

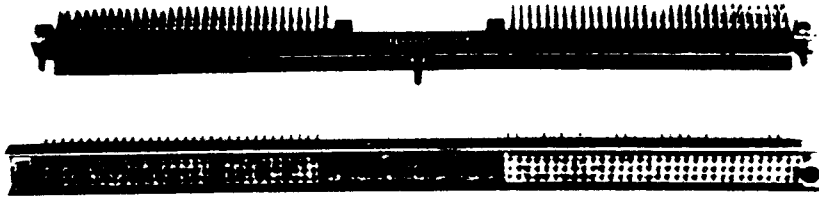

2.1 Characteristics

2.1.1	Environmental category	55/125/56
2.2.1	Low air pressure severity	300 mbars
2.1.3	Number of contacts	2 x 64 = 128, 2 x 96 = 192
2.1.4	Contact termination style	Solder, solderless wrap.
2.1.5	Maximum current rating at 85°C:	
2.1.5.1	Per individual contact in isolation	3 amps
2.1.5.2	Per contact through all contacts simultaneously	2 amps
2.1.6	Contact finish	Gold plated

2.1.7	dc or ac Working voltage at sea level	350 volts
2.1.8	Polarization	Polarized by male and female guides
2.1.9	Insert material	Plastic
2.1.10	Sealing	Non sealed
2.1.11	Housing material	Aluminium alloy
2.1.12	Housing finish	Chromate conversion

3 Specification

BS 9525 F0031

4 Related Documents

BS 9520

BS 9525

Defence Standard Guide Sheet C/011

Connectors Electrical, Two-Part Printed Board, Pattern Number 9525 F0033

1 Description

Multi-contact, 2 part low-profile connector with 2mm pitch replaceable contacts, arranged in one or two rows according to number of ways. Polarized mouldings with additional polarization using dummy contacts. Fully shrouded male contacts, crimp and through-board solder terminations. Latching optional. Intended as a low voltage connector in high density packaging applications.

2 Pattern 9525 F0033 - Illustration

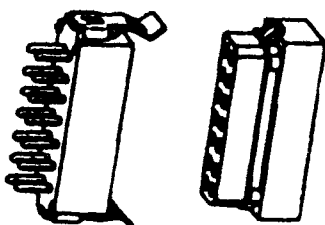

2.1 Characteristics

2.1.1	Environmental category	55/125/56
2.1.2	Low air pressure severity	300 mbar
2.1.3	Number of contacts	2, 3, 4, 5, 6, 7, 8, 10, 12, 14, 16, 17, 18, 20, 26, 34
2.1.4	Contact termination style	Crimp and through-board solder
2.1.5	Maximum current rating at 85°C:	
2.1.5.1	Per individual contact in isolation	1.75 amps
2.1.5.2	Per contact through all contacts simultaneously	1.5 amps
2.1.6	Contact finish	Gold plated

2.1.7	dc or ac peak Working voltage at sea level	120 volts
2.1.8	Polarization	Moulding feature and dummy contacts
2.1.9	Sealing	Unsealed
2.1.10	Housing material	Glass filled polyester
2.1.11	Housing finish	Natural

3 Specification

BS 9525 F0033

4 Related Documents

BS 9520

BS 9525

Defence Standard Guide Sheet C/012

Connectors Electrical, Two-Part Printed Board, Pattern Number 9525 F0036

1 Description

Multi-contact, surface mount (non-solder) clamp connector, for direct interconnection of flexible flat conductor cable with rigid printed boards. Low-profile moulded clamp (coupling device) with cam-action sliding locking feature and asymmetric polarizing guides. For use with polyester insulated cable having 20, 34 or 40 conductors and suitable for blind mating.

2 Pattern 9525 F0036 - Illustration

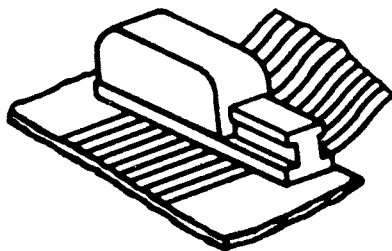

2.1 Characteristics

2.1.1	Environmental category	55/105/21
2.1.2	Low air pressure severity	300 mbar
2.1.3	Number of cable conductors	20, 34 and 40
2.1.4	Conductor	Flat
2.1.5	Maximum current rating at 85°C:	
2.1.5.1	Per individual contact in isolation	1.75 amps (40 conductors), 2.0 amps (34 conductors), 3.0 amps (20 conductors)
2.1.5.2	Per contact through all contacts simultaneously	0.3 amps (40 conductors), 0.4 amps (34 conductors), 0.9 amps (20 conductors)
2.1.6	Conductor finish	Pre-tinned

2.1.7	dc or ac peak Working voltage at sea level	210 volts (40 conductors), 280 volts (34 conductors), 420 volts (20 conductors)
2.1.8	Polarization	Asymmetric guide pins
2.1.9	Sealing	Unsealed
2.1.10	Clamp material	Glass-filled thermoplastic with nylon interliner
2.1.11	Clamp finish	Natural

3 Specification

BS 9525 F0036

4 Related Documents

BS 9520

BS 9525

Defence Standard guide Sheet C/013

Connectors Electrical, Two-Part Printed Board, Pattern Number 9525 F0042

1 Description

Multi-contact printed board electrical interconnection interface system, unsealed, with parallel mounting for single, double sided and multilayer boards up to 3.5 mm thickness.

2 Pattern 9525 F0042 - Illustration

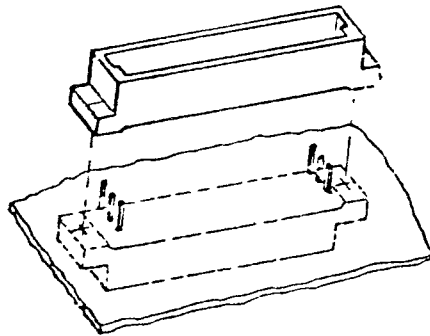

2.1 Characteristics

2.1.1	Environmental category	55/125/56
2.1.2	Low air pressure severity	300 mbars
2.1.3	Number of contacts	96
2.1.4	Contact termination style	Female rear plug-in
2.1.5	Maximum current rating at 50°C:	
2.1.5.1	Per individual contact in isolation	Derating curve 2.5 amps maximum
2.1.5.2	Per contact through all contacts simultaneously	Derating curve 1.25 amps maximum
2.1.6	Contact finish	Gold plated

DEF STAN 59-35 (PART 0)/3
SECTION 4
ANNEX C (CONTD)

- | | | |
|--------|--|--|
| 2.1.7 | dc or ac peak Working voltage at sea level | 350 volts |
| 2.1.8 | Polarization | 1. Assymmetrical Housing
2. Key/keyway combinations |
| 2.1.9 | Sealing | Unsealed |
| 2.1.10 | Housing material | Hard thermosetting plastic |
| 2.1.11 | Housing finish | Natural |

3 Specification

BS 9525 F0042

4 Related Documents

BS 9520

BS 9525

Defence Standard Guide Sheet C/014

Connectors Electrical, Two-Part Printed Board, Pattern Number 9525 F0043

1 Description

Multi-contact, 2 part printed board connector with parallel or perpendicular mounting. Replaceable contacts with through-board solder terminations arranged in two or three rows. Contacts can be orientated longitudinally or transversely to the connector axis in the mating plane. Polarization by pins with a guide pin in the free connector.

2 Pattern 9525 F0043 - Illustration

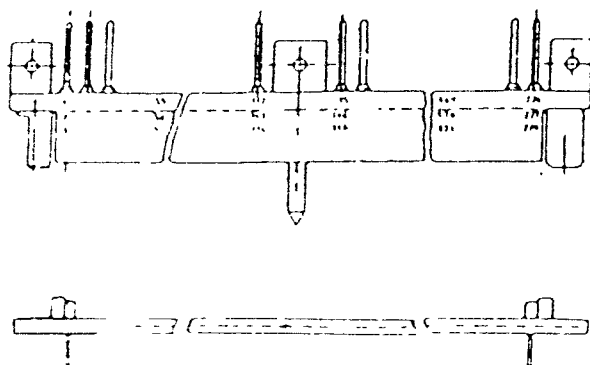

2.1 Characteristics

2.1.1	Environmental category	55/125/56
2.1.2	Low air pressure severity	300 mbar
2.1.3	Number of contacts	57, 76, 152, 228
2.1.4	Contact termination style	Solder
2.1.5	Maximum current rating at 85°C:	
2.1.5.1	Per individual contact in isolation	3 amps
2.1.5.2	Per contact through all contacts simultaneously	2 amps
2.1.6	Contact finish	Gold plated

2.1.7	dc or ac peak Working voltage at sea level	350 volts
2.1.8	Polarization	Polarizing pins
2.1.9	Sealing	Unsealed
2.1.10	Housing material	Aluminium alloy
2.1.11	Housing finish	Gold Chromate conversion

3 Specification

BS 9525 F0043

4 Related Documents

BS 9520

BS 9525

Section Five. Radio Frequency Connectors

1 Scope

This Section describes the various series of radio frequency connectors selected for MOD use together with certain characteristic information.

2 Definitions

2.1 For the purpose of this Defence Standard, the following definitions are specific to radio frequency connectors and are additional to those in Section 1 Clause 3.

2.1.1 Adaptor. A component to permit electrical interconnection between 2 or more connectors when direct connection is not achievable or suitable. An adaptor is described by what it is, not what it does ie an adaptor connecting 2 plugs is termed "adaptor, socket/socket".

2.1.2 Plug. A connector featuring the active part of the coupling mechanism, unless otherwise defined in a detail specification.

2.1.3 Reflection Factor (r). The ratio of the voltage magnitude of the reflected wave to the voltage magnitude of the incident wave.

2.1.4 Series. A range of radio frequency connectors having a common mating face.

Note: "Common" in this context means intermateability without compromise of performance rather than conforming to a single set of mechanical requirements.

2.1.5 Socket. A connector featuring the coupling mechanism complimentary to the plug.

2.1.6 Voltage Standing Wave Ratio (VSWR). The ratio of the maximum value to the minimum value of the voltages measured on a low-loss homogeneous transmission line.

3 Connector Style Reference Numbers

In the British Standard system, BS 9000 have a defined table for style references. The CECC 22000 system does not define style references consistently, therefore, style references are not consistent with the detail specification number.

4 Assessment Levels

4.1 The CECC system has assessment levels U (Utility) and H (Professional civilian use in a benign environment). These levels do not address the full requirement for military application. A further level L for military requirements is in course of preparation.

Issued January 1990

DEF STAN 59-35 (PART 0)/2
SECTION 5 (CONTD)

4.2 The British Standard system has assessment levels B (Basic) and F (Full).

4.3 The assessment levels for the 2 different systems do not directly relate, however, an order of precedence in descending level of assessment would be L/F, H, B, U.

Guide Sheet No	Connector Series	Assessment Level	BS 9210 Ref	Termination method					Impedance (Ohms)	Climatic Category	Reflection factor (r) - straight cabled styles		Reflection factor (r) - rt angle cabled styles		Connector Styles	Reflection factor - Adaptors		Adaptor Styles
				Soldered	Crimped	Clamped	Crimped	Soldered			GHz	f In GHz	GHz	f in GHz		GHz	f in GHz	
D/001	BNC	B	N0004	*		*			50	55/155/21	0.3 - 3.0	0.10 max	0.3 - 3.0	0.10 max			not applicable	
D/001	BNC	B	F0033	*		*			50	55/155/21	0.3 - 3.0	0.13 max						
D/002	N	F	F0016	*		*			50	55/155/56	to 3.0 to 12.0	0.070 max 0.011 max		not measured			not measured	
D/003	SMA	F	N0006 Iss 2	*		*		*	50	55/155/21	2.0 - 12.4 2.0 - 18.0	0.090 +0.010f 0.034 +0.004f	2.0 - 12.4 2.0 - 12.4	0.090 +0.010f 0.048 +0.004f	Flexible cable styles semi rigid cable styles	2.0 - 18.0 2.0 - 12.4	0.048 +0.004f 0.090 +0.010f	straight adaptors right angle adaptors
D/003	SMA	F	F0017	*		*			50	55/155/21	2.0 - 12.4	0.091 +0.0096f	2.0 - 12.4	0.091 +0.0013f	Flexible cable styles			
D/003	SMA	F	F004E	*		*			50	55/155/21	2.0 - 12.4	0.090 +0.010f	2.0 - 12.4	0.090 +0.010f	Flexible cable styles			
D/003	SMA	F	F0034						50	55/155/21	2.0 - 18.0	0.090 +0.007f	2.0 - 18.0	0.090 +0.010f	MIC & striplng styles			
D/003	SMA	F	F0035	*			*		50	55/155/21	2.0 - 12.4 2.0 - 18.0	0.048 +0.0043f 0.048 +0.0043f	2.0 - 12.4	0.048 +0.043f			not measured	
D/003	SMA	F	F0048	*		*	*		50	55/105/21	2.0 - 12.4 2.0 - 18.0	0.048 +0.026f	2.0 - 12.4 2.0 - 18.0	0.08 +0.026f 0.048 +0.004f	Semi rigid standard Semi rigid HI Performance			
D/004	SSMA	F	F0044	*			*	*	50	55/155/21	to 12.4 to 18.0	0.091 +0.0096f 0.34 +0.0036f	to 12.4 to 12.4	0.091 +0.0113f 0.048 +0.0040f	Flexible cable styles Semi rigid cable styles	to 18.0	0.048 +0.0043f	straight adaptors
D/005	SMB	F	F0026	*		*			50	55/155/21	0.5 - 4.0	0.19 max	0.5 - 4.0	0.25 max	Flexible cable styles	0.5 - 4.0	0.25 max	straight adaptors
D/006	SMB	B+	F0022	*	*		*		75	40/100/21	Time domain measurement:		see specification					
D/007	SMC	F	F0027	*		*		*	50	55/155/21	0.1 - 4.0 4.0 - 6.0	0.17 max 0.25 max	0.1 - 4.0 4.0 - 6.0	0.22 max 0.33 max		0.1 - 4.0 4.0 - 6.0	0.22 max 0.33 max	straight adaptors right angle adaptors
Notes	1			5	5	5	5	5	3			notes 2, 6		notes 2, 6		2, 6, 8		

1. B+ Indicates Basic Assessment with additional tests.
2. Figures are typical. See individual specifications for values relating to individual styles and variants.
3. Detail specifications may include unmatched styles.
4. Test voltages are d.c. or a.c. peak at 50 Hz. RF working voltages may vary from these figures.
5. Details relate to termination to coaxial cables. Specifications may also include non-cabled styles.
6. VSWR may be calculated from reflection factor r where $VSWR = \frac{1+p}{1-p}$
7. Ag = silver plated Au = gold plated
8. Not applicable to unmatched adaptors, eg T adaptors.

TABLE D-2

CROSS REFERENCE OF CABLE TYPE TO CONNECTOR STRIPS

CABLE TYPE	SIZE +	VARIANT CODE	IMP.	BNC	N	SMA	50 OHM SMB	75 OHM SMP	SMC	SSMA	SSMB	VCX
MIL-C-17/151	0.047 INS	-										CECC
URM 110 RG 178,404 MIL-C-17/93	2.00	AB	50			BSI	BSI CECC		BSI CECC	BSI		CFCC
RG 405 MIL-C-17/133	2.21 0.085 INS	PK	50			BSI CFCC	CECC		BSI CECC	BSI		CECC
URM 95	2.50	AC	50			BSI	BSI CFCC		BSI CECC	BSI		
URM 111 RG 179,179B/U	2.80	BB	75				CECC	BSI	CFCC			
URM 109,116 RG 174,316 MIL-C-M17/113	3.00	AE	50			BSI CECC	BSI CECC		BSI CECC	BSI		CECC
MIL-C-M17/152	3.61	AF	50									CECC
RG 402	3.61	PM	50			BSI CECC	BSI CECC		BSI CECC			
RG 402 MICROPOROUS PTFE	3.61	PO	50			BSI						
URM 72,108 RG 303	4.75	AH	50	BSI CECC		BSI						
URM 43,76 RG 58	5.21	AJ	50	BSI CECC	BSI	BSI CECC						
URM 104, 106 RG 302	5.50	BH	75									
URM 301 RG 142,223 RG 400	5.55	AK	50	BSI CECC	BSI	BSI CECC						
URM 70,210	6.05	BJ	75									
URM 90,117,306 RG 59,140	6.25	BK	75	BSI CECC								
RG 401	6.40	PO	50									
URM RG 212,222	8.54	AN	50		BSI							
URM 102,107	10.00	AO	50		BSI							
URM 67, URM 304 RG 213	10.60	AP	50		BSI							
RG 165	10.67	AO	50		BSI							
URM 91,112 RG 115,214, RG 225,393	11.30	AR	50		BSI							
EQUIP. WIRE	-	ZZ		BSI CECC	BSI	BSI CECC	BSI CFCC		BSI CECC	BSI		CFCC

- NOTES:
1. The two letter variant codes given in the table above are assigned in BS 9210 Generic data tables, further letters (not shown) denote the appropriate hexagonal crimping die sizes.
 2. Not all cables listed are suitable for crimping because some have copper covered steel cores.
 3. Some cables listed are DOUBLE BRAIDED or SEMI RIGID.
 4. Cables in CECC Specifications, type variations are difficult to tabulate as they are not consistent in their allocation.
 5. + All Dimensions are in millimetres unless otherwise specified.
 6. EIA flange connectors use proprietary cables only, see guide sheet at Annex E for details.

Def Stan Guide Sheets for Connectors Electrical, Radio Frequency

D.1 This Annex contains Guide Sheets for connectors electrical, radio frequency, for Ministry of Defence use.

D.2 Defence Standard Guide Sheets give a summary of some technical information which will enable designers or users to determine whether or not the candidate connector patterns might be suitable to meet the requirement for a particular application. Final selection should only be made after full consideration of any specific Service requirements and all the relevant features and performance parameters of the candidate connector series. This will require study and definitive interpretation of the relevant detail specifications. Attention should also be given to the NOTE on page 2 of this Standard.

D.3 Tabulated below is a list of individual Guide Sheets which have been prepared for connectors electrical, radio frequency, together with Standards related to this guide.

GUIDE SHEET REFERENCE	CONNECTOR SERIES	SPECIFICATION NUMBER	DEF STAN NUMBER	PAGE NUMBER
D/001	BNC	BS 9210 N0004 F0033 CECC 22121 - 001/007 - 801/816	59-35 Part 4 Section 1	D-3
D/002	N	BS 9210 F0016		D-4
D/003	SMA	BS 9210 N0006 ISSUE 2 F0017 F0034 F0035 F0046 F0048 CECC 22111 - 801/820	59-35 Part 4 Section 9A Section 9B	D-5
D/004	SSMA	BS 9210 F0044 CECC 22161 - 801/815		D-7
D/005	SMB (50 OHM)	BS 9210 F0026 CECC 22131 - 801/811		D-8
D/006	SMB (75 OHM)	BS 9210 F0022		D-9
D/007	SMC	BS 9210 F0027 CECC 22141 - 801/811		D-10
D/008	MCX	CECC 22221 - 801/814		D-11
D/009	EIA	CECC 22151 - 001/007 - 801/816	Interim 59-35 Part 4 Section 12	D-12

Issued January 1990

DEF STAN 59-35 (PART 0)/2

SECTION 5

ANNEX D (CONTD)

NOTE: Characteristics given in the Guide Sheets are typical and are given for guidance only, reference should be made to the appropriate detail specifications for specific values.

D.4 If any difficulties arise from the information contained in the Guide Sheets, then clarification should be sought from the Master Specification Officer (MSO) who is the consulting authority for Connectors electrical on behalf of the Ministry of Defence. The MSO may be contacted at the following address:

Procurement Executive
Ministry of Defence
Electronics Components Group (RSRE)
Empress State Building
Lillie Road
Fulham
LONDON SW6 1TR

DEFENCE STANDARD GUIDE SHEET D/001

Radio Frequency Connector - Series - BNC

1 Description

Coaxial RF connector with bayonet coupling.

1.1 Assessment level: BASIC/U

2 Characteristics

- | | |
|--|--|
| 2.1 Impedance: | 50 ohms |
| 2.2 Environmental category: | 55/155/21 |
| 2.3 Frequency range: | Up to 3 GHz according to
Style/Variant |
| 2.4 Sealing: | see relevant detail
specifications. |
| 2.5 Reflection factor:
VSWR: | 0.024 (1 GHz) 0.091 (3 GHz)
1.05 (1 GHz) 1.20 (3 GHz) |
| 2.6 Screening effectiveness: | 55dB |
| 2.7 Cable entry sizes:
Matched:
Unmatched:
Equip Wire: | 3.00 mm to 6.25 mm
AH/AJ/AK
BK
ZZ |
| 2.8 Working voltage: | see relevant detail
specifications. |
| 2.9 Variants: | see relevant detail
specifications. |

DEF STAN 59-35 (PART 0)/2

SECTION 5

ANNEX D (CONTD)

3 Specifications

BS 9210 Generic data.

BS 9210 N0004 Clamped outer, soldered captive inner. Assess BASIC.

Body: Silver plated or Nickel plated. Pin: Silver plated.

F0033 Crimped outer, crimped captive inner.

CECC 22000 Generic Specification

CECC 22120 BNC Sectional Specification, Series BNC

CECC Detail specifications

22121-001/007 Clamped outer conductor, soldered captive contact. Assess U

Body: Silver plated or Nickel plated. Pin: Silver plated.

-801/816

4 Related Documents

BS 2316 - Radio frequency cables

BS 5310 - Hand crimping tools

DEFENCE STANDARD GUIDE SHEET D/002

Radio Frequency Connector - Series - N

1 Description

Coaxial RF connector with screw coupling.

1.1 Assessment level: FULL/H

2 Characteristics

- | | |
|-------------------------------------|--|
| 2.1 Impedance: | 50 ohms |
| 2.2 Environmental category: | 55/155/56 |
| 2.3 Frequency range: | Up to 11 GHz according to
Style/Variant |
| 2.4 Sealing: | see relevant detail
specifications. |
| 2.5 Reflection factor: | 0.024 (1 GHz) 0.091 (3 GHz) |
| VSWR: | 1.05 (1 GHz) 1.20 (3 GHz) |
| 2.6 Screening effectiveness: | 100dB |
| 2.7 Cable entry sizes: | 5.21 mm to 11.30 mm |
| Matched: | AJ/AK/AN/AO/AP/AQ/AR |
| Equip Wire: | ZZ |
| 2.8 Working voltage: | see relevant detail
specifications. |
| 2.9 Variants: | see relevant detail
specifications. |

Issued January 1990

DEF STAN 59-35 (PART 0)/2

SECTION 5

ANNEX D (CONTD)

3 Specifications

BS 9210 Generic data.

BS 9210 F0016 Clamped outer, soldered captive inner. Assess FULL.

Body: Black silver plate, silver plated or Nickel plated
Pin Silver or gold plated.

CECC 22000 Generic Specification

CECC 22210 Sectional Specification, Series N

CECC Detail Specifications

4 Related Documents

BS 2316 - Radio frequency cables

DEF STAN 59-35 (PART 0)/2

SECTION 5

ANNEX D (CONTD)

3 Specifications

BS 9210 Generic data.

BS 9210 N0006 Issue 2 Clamped or soldered outer, soldered captive inner.

Assess FULL

Body: Gold/gold cadmium alloy/nickel alloy/electro-deposited tin plate.

F0017 Crimped outer, soldered inner. Assess FULL

F0034 MIC, Microstrip, Stripline. Assess FULL

F0035 MIC, Hermetically Sealed Microstrip, Stripline. Assess FULL

F0046 Crimped outer, soldered inner. Assess FULL

F0048 Clamped or soldered outer, soldered inner. Assess FULL

CECC 22000 Generic Specification

CECC 22110 Sectional Specification, Series SMA

CECC Detail Specifications

22111-801/820 Soldered or crimped outer, soldered inner. Assess H

Body: Gold plate/Nickel plate/Stainless Steel.

4 Related Documents

BS 2316 - Radio frequency cables

BS 5310 - Hand crimping tools

DEFENCE STANDARD GUIDE SHEET D/004

Radio Frequency Connector - Series - SSMA

1 Description

Miniature coaxial RF connector with screw coupling.

1.1 Assessment level: FULL/H

2 Characteristics

- 2.1 Impedance:** 50 ohms
- 2.2 Environmental category:** 55/155/21, semi-rigid variant:
55/115/21
- 2.3 Frequency range:** According to Style/Variant
Braided cable Semi-rigid
Up to 38 GHz Up to 40 GHz
- 2.4 Sealing:** 100 kPa
- 2.5 Reflection factor:** 0.091 + 0.0096f 0.034 + 0.004f
VSWR: 1.2 + 0.025f 1.07 + 0.01f
- 2.6 Screening effectiveness:** 90 dB
- 2.7 Cable entry sizes:** 2.00 mm to 3.0 mm
Matched: AB/AC/AE/PK
Equip Wire: ZZ
- 2.8 Working voltage:** see relevant detail specifications.
- 2.9 Variants:** see relevant detail specifications.

Issued January 1990

DEF STAN 59-35 (PART 0)/2

SECTION 5

ANNEX D (CONTD)

3 Specifications

BS 9210 Generic data.

BS 9210 F0044 Solder or crimped outer, soldered inner. Assess FULL

Body: Gold plated/nickel alloy/stainless steel.

Pin: Gold plated.

CECC 22000 Generic Specification

CECC 22160 Sectional Specification, Series SSMA

CECC Detail specifications

22161-801/815 Clamped, soldered or crimped outer, soldered inner. Assess H

Body: Gold plate. Pin: Gold plated.

4 Related Documents

BS 2316 - Radio frequency cables

BS 5310 - Hand crimping tools

DEFENCE STANDARD GUIDE SHEET D/005

Radio Frequency Connector - Series - SMB - 50 OHM

1 Description

Miniature coaxial RF connector with snap-on coupling.

1.1 Assessment level: FULL/H

2 Characteristics

- 2.1** Impedance: 50 ohms
- 2.2** Environmental category: 55/155/21, semi-rigid variant:
55/105/21
- 2.3** Frequency range: According to Style/Variant
Braided cable Semi-rigid
Up to 4 GHz Up to 6 GHz
- 2.4** Sealing: see relevant detail
specifications.
- 2.5** Reflection factor: 0.091 + 0.0096f 0.034 + 0.0036f
VSWR: 1.2 + 0.025f 1.07 + 0.008f
- 2.6** Screening effectiveness: 70dB
- 2.7** Cable entry sizes: 2.00 mm to 6.90 mm
Matched: AB/AC/AE/BB/PK/PM
Equip Wire: ZZ
- 2.8** Working voltage: see relevant detail
specifications.
- 2.9** Variants: see relevant detail
specifications.

Issued January 1990

DEF STAN 59-35 (PART 0)/2

SECTION 5

ANNEX D (CONTD)

3 Specifications

BS 9210 Generic data.

BS 9210 F0026 Clamped outer, soldered inner. Assess FULL.

CECC 22000 Generic Specification

CECC 22130 Sectional Specification, Series SMB

CECC Detail specifications

22131-801/811 Clamped or crimped outer, soldered inner. Assess H

Body: Gold plate. Pin: Gold plated.

4 Related Documents

BS 2316 - Radio frequency cables

BS 5310 - Hand crimping tools

DEFENCE STANDARD GUIDE SHEET D/006

Radio Frequency Connector - Series - SMB - 75 OHM

1 Description

Miniature coaxial RF connector with screw snap-on or latching coupling. This series is larger than, and not intermateable with the similar Series SMB-50 ohm described on guide sheet D005.

1.1 Assessment level: BASIC with addition of bump, vibration, shock, impact, resistance to solvents and industrial atmosphere.

2 Characteristics

- | | | |
|------------|--|--|
| 2.1 | Impedance: | 50 ohms |
| 2.2 | Environmental category: | 40/100/21 |
| 2.3 | Frequency range: | specified for data transmission use, but useable to 2 GHz |
| 2.4 | Sealing: | unsealed |
| 2.5 | Reflection factor: | specified in the time domain for a 1 ns risetime pulse. Typically 0.01 max. See relevant detail specification. |
| 2.6 | Screening effectiveness: | not specified |
| 2.7 | Cable entry sizes:
Matched: | 2.8 mm to 6.9 mm
BB |
| 2.8 | Working voltage
(environmental test voltage): | 500V |
| 2.9 | Variants: | see relevant detail specifications. |

Issued January 1990

DEF STAN 59-35 (PART 0)/2

SECTION 5

ANNEX D (CONTD)

3 Specifications

BS 9210 Generic

BS 9210 F0022 Detail specification:

 crimped outer, soldered and crimped inner gold plated inner
 and outer contacts, nickel alloy on other body parts.

4 Related Documents

BS 5310 - Hand crimping tools

DEFENCE STANDARD GUIDE SHEET D/007

Radio Frequency Connector - Series - SMC

1 Description

Miniature coaxial RF connector with screw coupling.

1.1 Assessment level: FULL/H

2 Characteristics

- 2.1** Impedance: 50 ohms
- 2.2** Environmental category: 55/155/21, semi-rigid variant:
55/105/21
- 2.3** Frequency range: According to Style/Variant
Braided cable Semi-rigid
Up to 4 GHz Up to 6 GHz
- 2.4** Sealing: see relevant detail specifications.
- 2.5** Reflection factor: 0.091 + 0.0096f 0.034 + 0.0036f
1.2 + 0.025f 1.07 + 0.008f
- 2.6** Screening effectiveness: 90dB
- 2.7** Cable entry sizes: 2.00 mm to 3.0 mm
Matched: AB/AC/AE/PK/PM
Equip Wire: ZZ
- 2.8** Working voltage: see relevant detail specifications.
- 2.9** Variants: see relevant detail specifications.

Issued January 1990

DEF STAN 59-35 (PART 0)/2

SECTION 5

ANNEX D (CONTD)

3 Specifications

BS 9210 Generic data.

BS 9210 F0027 Solder or clamped outer, soldered inner. Assess 4

CECC 22000 Generic Specification

CECC 22140 Sectional Specification, Series SMC

CECC Detail specifications

22141-801/811 Clamped or crimped outer, soldered inner. Assess 4

Body: Gold plate. Pin: Gold plated.

4 Related Documents

BS 2316 - Radio frequency cables

BS 5310 - Hand crimping tools

DEFENCE STANDARD GUIDE SHEET D/008

Radio Frequency Connector - Series - MCX

1 Description

Miniature coaxial RF connector with screw coupling.

1.1 Assessment level: H

2 Characteristics

- | | | | |
|-------------------------------------|---|-------------|---------|
| 2.1 Impedance: | 50 ohms | | |
| 2.2 Environmental category: | 55/155/21, semi-rigid variant:
55/105/21 | | |
| 2.3 Frequency range: | According to Style/Variant | | GHz |
| | Braided cable | Semi-rigid | R Angle |
| | Up to 3 GHz | Up to 3 GHz | Up to 3 |
| 2.4 Sealing: | see relevant detail specifications. | | |
| 2.5 Reflection factor: | 0.15 | 0.15 | 0.24 |
| VSWR: | 1.353 | 1.353 | 1.632 |
| 2.6 Screening effectiveness: | 70dB | | |
| 2.7 Cable entry sizes: | 2.00 mm to 3.0 mm | | |
| 2.8 Working voltage: | see relevant detail specifications. | | |
| 2.9 Variants: | see relevant detail specifications. | | |

Issued January 1990

DEF STAN 59-35 (PART 0)/2

SECTION 5

ANNEX D (CONTD)

3 Specifications

CECC 22000 Generic Specification

CECC 22220 Sectional Specification, Series MCX

CECC Detail specifications

22221-801/814 Clamped, crimped or soldered outer, soldered inner. Assess H
 Body: Gold plate. Pin: Gold plated.

4 Related Documents

BS 2316 - Radio frequency cables

BS 5310 - Hand crimping tools

Issued January 1990

DEF STAN 59-35 (PART 0)/2

SECTION 5

ANNEX D (CONCLD)

3 Specifications

CECC 22000 Generic Specification

CECC 22150 Sectional Specification, Series EIA Flange

CECC Detail Specifications

4 Related Documents

DEFENCE STANDARD 59-35 (Part 4) Section 12/1

LIST OF CECC HARMONIZED DETAIL SPECIFICATIONS WITH
SUMMARY FEATURES FOR RADIO FREQUENCY CONNECTORS

- DA.1** The following pages list the individual CECC Detail Specifications for each radio frequency connector series and a summary of the main mechanical features.
- DA.2** Connectors complying with some of the Detail Specifications listed are not yet available from approved Manufacturers. They are included in the lists to encourage equipment Manufacturers to select from these Detail Specifications thereby proving to connector Manufacturers their preference to purchase CECC Approved connectors.
- DA.3** Detail Specifications which have approved connectors currently available are identified by an asterisk.

DEF STAN 59-35 (PART 0)/3

SECTION 5

APPENDIX A TO ANNEX D (CONTD)

22121 DETAIL SPECIFICATION - SERIES BNC - 50 OHM MATING FACE TO IEC 169-8

List of harmonised detail specifications with summary of features.

Body finish: Most styles available silver plated or non-tarnish alloy: see variants on detail specifications

<u>NUMBER</u>	<u>FEATURES</u>	<u>NOTES</u>
22121		
* -801	Pl St FC Cl	
* -802	Pl St FC Cr	
* -803	Pl RA FC Cl	
* -804	Sk St 4H FC Cl	
* -805	Sk St FC Cl	
* -806	Sk St 1H FC Cl	rear mounting
* -807	Sk St 4H SB	
* -808	Sk St 1H SB	front mounting
* -809	Sk St 1H SB	front mounting, panel and barrier sealed
* -810	Sk St 1H SB	front mounting, hermetically sealed
* -811	Sk RA 1H SB	front mounting, panel and barrier sealed
* -812	Ad RA Pl/Sk	
* -813	Ad St Pl/Pl	joins two sockets
* -814	Ad St Sk/Sk	joins two plugs
* -815	Ad St 4H Sk/Sk	joins two plugs
* -816	Ad Te Sk/Sk/Pl	

EXPLANATION OF ABBREVIATIONS

Ad	<u>Adaptor</u> : mating faces shown as Pl/Pl etc
Cl	<u>Clamped</u> cable connection
Cr	<u>Crimped</u> cable connection
FC	<u>Flexible</u> coaxial <u>Cable</u>
PB	<u>Printed</u> (circuit) <u>Board</u> style
Pl	<u>Plug</u>
RA	<u>Right</u> <u>Angle</u>
SB	<u>Solder</u> <u>Bucket</u> (for equipment wire)
Sk	<u>Socket</u>
Sl	<u>Solderless</u> cable connection
SR	<u>Semi-Rigid</u> coaxial cable
St	<u>Straight</u>
Te	<u>Tee</u> (adaptor)
1H	<u>single</u> (1) <u>Hole</u> (bulkhead) mounting
2H	<u>2</u> <u>Hole</u> flange mounting
4H	<u>4</u> <u>Hole</u> flange mounting
*	<u>See</u> Clause DA-3

22211 DETAIL SPECIFICATION - SERIES N - 50 OHM MATING FACE TO IEC 169-16

List of harmonised detail specifications with summary of features.

Body finish: Most styles available silver plated or non-tarnish alloy body
 silver or gold contact: see variants on detail specifications.

<u>NUMBER</u>	<u>FEATURES</u>	<u>NOTES</u>
22211		
-801	Pl St FC Cl	
-802	Pl St FC Cr	
-803	Pl RA FC Cl	
-804	Pl RA FC Cr	
-805	Sk St FC Cl	
-806	Sk St FC Cr	
-807	Sk St 1H SB	front mounting, panel and barrier sealed
-808	Sk St 4H SB	
-809	Sk St 4H FC Cr	
-810	Pl St 4H SB	
-811	Sk St 1H FC Cr	rear mounting
-812	Pl St SR	variants for RG-401 and RG-402
-813	Sk St 1H SR	variants for RG-401 and RG-402, rear mounting
-814	Sk St 4H SR	variants for RG-401 and RG-402
-815	Ad St Sk/Sk/Sk	joins two plugs
-816	Ad St Pl/Pl	joins two sockets
-817	Ad St 1H Sk/Sk	joins two plugs
-818	Pl RA FC Cr	
-819	Sk St 4H FC Cl	
-820	Sk St 1H FC Cl	rear mounting

EXPLANATION OF ABBREVIATIONS

Ad	Adaptor: mating faces shown as Pl/Pl etc
Cl	Clamped cable connection
Cr	Crimped cable connection
FC	Flexible coaxial Cable
PB	Printed (circuit) Board style
Pl	Plug
RA	Right Angle
SB	Solder Bucket (for equipment wire)
Sk	Socket
Sl	Solderless cable connection
SR	Semi-Rigid coaxial cable
St	Straight
Te	Tee (adaptor)
1H	single (1) Hole (bulkhead) mounting
2H	2 Hole flange mounting
4H	4 Hole flange mounting
*	See Clause DA-3

DEF STAN 59-35 (PART 0)/3
SECTION 5
APPENDIX A TO ANNEX D (CONTD)

22111 DETAIL SPECIFICATION - SERIES SMA - 50 OHM MATING FACE TO IEC 169-15

List of harmonised detail specifications with summary of features.

Body finish: Most styles available gold or passivated stainless steel: see variants on detail specifications.

<u>NUMBER</u>	<u>FEATURES</u>	<u>NOTES</u>
22111		
* -801	Pl St SR 18.0	uses cable conductor as inner contact, RG-402 only
* -802	Pl St SR 18.0	variants for RG-402 and RG-405
* -803	Pl RA SR 12.4	variants for RG-402 and RG-405
* -804	Sk St SR 18.0	variants for RG-402 and RG-405
* -805	Sk St 4H SR 18.0	variants for RG-402 and RG-405
* -806	Sk St 2H SR 18.0	variants for RG-402 and RG-405
* -807	Sk St 4H SB	
* -808	Sk St 2H SB	
* -809	Pl St FC Cr 12.4	
* -810	Pl RA FC Cr 12.4	
* -811	Sk St PB	
* -812	Sk RA PB	
* -813	Sk St 1H SB	rear mounting
* -814	Sk St 1H SB	front mounting, panel sealed
* -815	Pl St SR Sl 18.0	uses cable conductor as inner contact, RG-402 only
* -816	Pl St SR Sl 18.0	variants for RG-402 and RG-405
* -817	Pl RA SR Sl 12.4	variants for RG-402 and RG-405
* -818	Sk St SR Sl 18.0	variants for RG-402 and RG-405
* -819	Sk St 4H SR Sl 18.0	variants for RG-402 and RG-405
* -820	Sk St 1H SR Sl 18.0	rear mounting.

EXPLANATION OF ABBREVIATIONS

Ad	<u>Adaptor</u> : mating faces shown as Pl/Pl etc
Cl	<u>Clamped</u> cable connection
Cr	<u>Crimped</u> cable connection
FC	<u>Flexible</u> coaxial <u>Cable</u>
PB	<u>Printed</u> (circuit) <u>Board</u> style
Pl	<u>Plug</u>
RA	<u>Right</u> <u>Angle</u>
SB	<u>Solder</u> <u>Bucket</u> (for equipment wire)
Sk	<u>Socket</u>
Sl	<u>Solderless</u> cable connection
SR	<u>Semi-Rigid</u> coaxial cable
St	<u>Straight</u>
Te	<u>Tee</u> (adaptor)
1H	<u>single</u> (1) <u>Hole</u> (bulkhead) mounting
2H	<u>2</u> <u>Hole</u> <u>flange</u> mounting
4H	<u>4</u> <u>Hole</u> <u>flange</u> mounting
12.4	<u>upper</u> frequency limit of style in GHz
*	See Clause DA-3

22161 DETAIL SPECIFICATION - SERIES SSMA - 50 OHM MATING FACE TO IEC 169-1

List of harmonised detail specifications with summary of features.

Body finish: Most styles available gold or passivated stainless steel: see variants on detail specifications.

<u>NUMBER</u>	<u>FEATURES</u>	<u>NOTES</u>
22161		
-801	Pl St SR 18.0	uses cable as inner contact, RG-405 only
-802	Pl St SR 18.0	RG-405 only
-803	Pl St FC Cr 12.4	
-804	Pl RA SR 12.4	RG-405 only
-805	Sk St SR 18.0	RG-405 only
-806	Sk St SR 1H 18.0	RG-405 only, panel sealed, rear mounting
-807	Sk St FC Cr 12.4	
-808	Sk St 4H SB	
-809	Sk St 1H SB 12.4	rear mounting
-810	Sk St 1H SB	rear mounting, panel sealed
-811	Sk St PB	
-812	Sk RA PB	
-813	Ad St Pl/Pl	joins two sockets
-814	Ad St Sk/Sk	joins two plugs
-815	Ad RA Pl/Sk	

EXPLANATION OF ABBREVIATIONS

Ad	<u>Adaptor</u> : mating faces shown as Pl/Pl etc
Cl	<u>Clamped</u> cable connection
Cr	<u>Crimped</u> cable connection
FC	<u>Flexible</u> coaxial <u>Cable</u>
PB	<u>Printed</u> (circuit) <u>Board</u> style
Pl	<u>Plug</u>
RA	<u>Right</u> <u>Angle</u>
SB	<u>Solder</u> <u>Bucket</u> (for equipment wire)
Sk	<u>Socket</u>
Sl	<u>Solderless</u> cable connection
SR	<u>Semi-Rigid</u> coaxial cable
St	<u>Straight</u>
Te	<u>Tee</u> (adaptor)
1H	<u>single</u> (1) <u>Hole</u> (bulkhead) mounting
2H	<u>2</u> <u>Hole</u> flange mounting
4H	<u>4</u> <u>Hole</u> flange mounting
12.4	<u>upper</u> frequency limit of style in GHz
*	See Clause DA-3

DEF STAN 59-35 (PART 0)/3
SECTION 5
APPENDIX A TO ANNEX D (CONTD)

22131 DETAIL SPECIFICATION - SERIES SMB - 50 OHM MATING FACE TO IEC 169-18

List of harmonised detail specifications with summary of features.

Body finish: Most styles available gold or non-tarnish alloy: see variants on detail specifications.

Special note on SMB Series: plugs have female centre contacts
 sockets have male centre contacts

<u>NUMBER</u>	<u>FEATURES</u>	<u>NOTES</u>
22131		
* -801	Pl St FC/SR Cl	includes flexible and semi-rigid cable variants
* -802	Sk St 1H SB	front mounting
-803	Sk St PB	
-804	Sk RA PB	
* -805	Pl RA FC/SR Cl	includes flexible and semi-rigid cable variants
-806	Sk RA 1H SB	front mounting
* -807	Pl St FC Cr	
* -808	Sk St 1H FC Cr	rear mounting or free
* -809	Pl RA FC Cr	
* -810	Sk St 1H FC Cl	rear mounting or free
-811	Sk St 1H SB	rear mounting
* -001	Sk St Fc Cr	
* - 002	Sk St Fc Cl	

EXPLANATION OF ABBREVIATIONS

Ad	<u>Adaptor</u> : mating faces shown as Pl/Pl etc
Cl	<u>Clamped</u> cable connection
Cr	<u>Crimped</u> cable connection
FC	<u>Flexible</u> coaxial <u>Cable</u>
PB	<u>Printed</u> (circuit) <u>Board</u> style
Pl	<u>Plug</u>
RA	<u>Right</u> <u>Angle</u>
SB	<u>Solder</u> <u>Bucket</u> (for equipment wire)
Sk	<u>Socket</u>
Sl	<u>Solderless</u> cable connection
SR	<u>Semi-Rigid</u> coaxial cable
St	<u>Straight</u>
Te	<u>Tee</u> (adaptor)
1H	<u>single</u> (1) <u>Hole</u> (bulkhead) mounting
2H	<u>2</u> <u>Hole</u> flange mounting
4H	<u>4</u> <u>Hole</u> flange mounting
*	<u>See</u> Clause DA-3

22141 DETAIL SPECIFICATION - SERIES SMC - 50 OHM MATING FACE TO IEC 169-9

List of harmonised detail specifications with summary of features.

Body finish: Most styles available gold or non-tarnish alloy: see variants on detail specifications.

Special note on SMB Series: plugs have female centre contacts
sockets have male centre contacts

NUMBER FEATURES

NOTES

22141

* -801	P1 St FC/SR C1	includes flexible and semi-rigid cable variants
* -802	Sk St 1H SB	front mounting
-803	Sk St PB	
-804	Sk RA PB	
* -805	P1 RA FC/SR C1	includes flexible and semi-rigid cable variants
-806	Sk RA 1H SB	front mounting
* -807	P1 St FC Cr	
* -808	Sk St 1H FC Cr	rear mounting or free
* -809	P1 RA FC Cr	
* -810	Sk St 1H FC C1	rear mounting or free
-811	Sk St 1H SB	rear mounting
* -001	Sk St FC Cr	
* -002	Sk St FC C1	
* -007	Sk St 1H FC C1	

EXPLANATION OF ABBREVIATIONS

Ad	Adaptor: mating faces shown as P1/P1 etc
C1	Clamped cable connection
Cr	Crimped cable connection
FC	Flexible coaxial Cable
PB	Printed (circuit) Board style
P1	Plug
RA	Right Angle
SB	Solder Bucket (for equipment wire)
Sk	Socket
S1	Solderless cable connection
SR	Semi-Rigid coaxial cable
St	Straight
Te	Tee (adaptor)
1H	single (1) Hole (bulkhead) mounting
2H	2 Hole flange mounting
4H	4 Hole flange mounting
*	See Clause DA-3

DEF STAN 59-35 (PART 0)/3
SECTION 5
APPENDIX A TO ANNEX D (CONTD)

22221 DETAIL SPECIFICATION - SERIES MCX - 50 OHM MATING FACE TO CECC 22220

List of harmonised detail specifications with summary of features.

Body finish: Most styles available gold body: see variants on detail specifications

<u>NUMBER</u>	<u>FEATURES</u>	<u>NOTES</u>
22221		
* -801	Pl St SR	RG-405 and MIL-C-17/151 (.047in)
* -802	Pl RA SR SB	RG-405 and MIL-C-17/151 (.047in)
* -803	Sk St 1H SR	RG-405 and MIL-C-17/151 (.047in)
* -804	Sk St 1H SB	front mounting
* -805	Sk RA 1H SB	front mounting
* -806	Sk St PB	two sizes
* -807	Sk RA PB	two sizes
* -808	Sk St SR	RG-405 and MIL-C-17/151 (.047in)
* -809	Sk St 1H	soldered mounting, hermetically sealed
* -810	Pl St FC Cr	
* -811	Sk St FC Cr	
* -812	Sk St 1H FC Cr	front mounting
* -813	Pl RA FC Cr	
* -814	Pl RA FC	low profile, soldered attachment to cable braid

EXPLANATION OF ABBREVIATIONS

Ad	Adaptor: mating faces shown as Pl/Pl etc
Cl	Clamped cable connection
Cr	Crimped cable connection
FC	Flexible coaxial Cable
PB	Printed (circuit) Board style
Pl	Plug
RA	Right Angle
SB	Solder Bucket (for equipment wire)
Sk	Socket
Sl	Solderless cable connection
SR	Semi-Rigid coaxial cable
St	Straight
Te	Tee (adaptor)
1H	single (1) Hole (bulkhead) mounting
2H	2 Hole flange mounting
4H	4 Hole flange mounting
*	See Clause DA-3

22201 DETAIL SPECIFICATION - SERIES TNC - 50 OHM MATING FACE TO IEC 169-17

List of harmonised detail specifications with summary of features.

Body finish: Most styles available silver plated or non-tarnish alloy: see variants on detail specifications

Plugs available with wire lock holes

<u>NUMBER</u>	<u>FEATURES</u>	<u>NOTES</u>
22201		
-801	Pl St FC Cl	
-802	Pl St FC Cr	
-803	Pl RA FC Cl	
-804	Pl RA FC Cr	
-805	Sk St FC Cr	
-806	Sk St 1H FC Cr	rear mounting, panel sealed
-807	Sk St 1H SB	front mounting
-808	Sk St 4H SB	
-809	Ad St Sk/Sk	joins two plugs
-810	Ad St Pl/Pl	joins two sockets
-811	Ad St 1H Sk/Sk	panel sealed, joins two plugs
-812	Sk St 1H SB	front mounting, panel and barrier sealed

EXPLANATION OF ABBREVIATIONS

Ad	<u>Adaptor</u> : mating faces shown as Pl/Pl etc
Cl	<u>Clamped</u> cable connection
Cr	<u>Crimped</u> cable connection
FC	<u>Flexible</u> coaxial <u>Cable</u>
PB	<u>Printed</u> (circuit) <u>Board</u> style
Pl	<u>Plug</u>
RA	<u>Right</u> <u>Angle</u>
SB	<u>Solder</u> <u>Bucket</u> (for equipment wire)
Sk	<u>Socket</u>
Sl	<u>Solderless</u> cable connection
SR	<u>Semi-Rigid</u> coaxial cable
St	<u>Straight</u>
Te	<u>Tee</u> (adaptor)
1H	<u>single</u> (1) <u>Hole</u> (bulkhead) mounting
2H	<u>2</u> <u>Hole</u> flange mounting
4H	<u>4</u> <u>Hole</u> flange mounting
*	<u>See</u> Clause DA-3

C Crown Copyright 1989

Published by and obtainable from:
Ministry of Defence
Directorate of Standardization
Kentigern House
65 Brown Street
GLASGOW G2 8EX

Tel No: 041-224-2332

Fax: 041-224-2503

This Standard may be fully reproduced except for sale purposes. The following conditions must be observed:

- 1 The Royal Coat of Arms and the publishing imprint are to be omitted.
- 2 The following statement is to be inserted on the cover:
'Crown Copyright. Reprinted by (name of organization) with the permission of Her Majesty's Stationery Office.'

Requests for commercial reproduction should be addressed to MOD Stan 1, Kentigern House, 65 Brown Street, Glasgow G2 8EX

The following Defence Standard file reference relates to the work on this Standard - D/D Stan/318/26/33.

Contract Requirements

When Defence Standards are incorporated into contracts users are responsible for their correct application and for complying with contract requirements.

Revision of Defence Standards

Defence Standards are revised when necessary by the issue either of amendments or of revised editions. It is important that users of Defence Standards should ascertain that they are in possession of the latest amendments or editions. Information on all Defence Standards is contained in Def Stan 00-00 (Part 3) Section 4, Index of Standards for Defence Procurement - Defence Standards Index published annually and supplemented periodically by Standards in Defence News. Any person who, when making use of a Defence Standard encounters an inaccuracy or ambiguity is requested to notify the Directorate of Standardization without delay in order that the matter may be investigated and appropriate action taken.

OBSOLESCENT

Ministry of Defence
Ministry of Aviation Supply

Defence Standard

59 - 35 (Part 1)

SECTION 1 / Issue 1

31st March 1971

**PLUGS AND SOCKETS,
ELECTRICAL
PATTERN 103**

~ OBSOLESCENT ~

**THIS DEFENCE STANDARD WILL NOT BE UPDATED AND IS
NOT TO BE USED FOR THE PURCHASE OF NEW EQUIPMENT**

AMENDMENT RECORD

AMENDMENT NUMBER	DATE	SIGNATURE
Amdt. 1	6 November 1980	Incorporated in reprints by Stan 12 (April '82)

PLUGS AND SOCKETS, ELECTRICAL

PATTERN 103

This Section of DEF STAN 59 - 35(PART 1) supersedes DEF-5325-1, dated September 1964 and references to Pattern 103, 'Plugs and sockets electrical' in DEF-5321, dated August 1960, and in SSM(L) 9 - 41, Part 14, dated 1st March 1966

1. This Section of DEF STAN 59 - 35(PART 1) specifies the requirements for plugs and sockets, electrical, Pattern 103, with soldered terminations for inter-chassis connection applications, for use by the Navy, Army, and Air Force Departments of the Ministry of Defence and by the Ministry of Aviation Supply.
2. This Section is to be used in conjunction with DEF STAN 59 - 35(PART 1) 'Plugs and sockets, electrical, with soldered terminations d.c. and low frequency applications', which is the generic specification.
3. Table I gives the details of standard ranges of plugs and sockets to be used in all future designs of equipment and for the maintenance, where practicable, of existing designs.
4. The imperial units used in this Standard reflect current trade practices as the items defined herein are interchangeable and fully mateable with items produced in the USA to a Military Specification in imperial units.
5. This Section, together with DEF STAN 59 - 35(PART 1), contains all the necessary technical information and it is the definitive specification for these items. It must be invoked for all tender and contract purposes.
6. Departments named in clause 1 are to implement this Section of DEF STAN 59 - 35(PART 1) from the date of issue.
7. This Section of DEF STAN 59 - 35(PART 1) has been agreed by all authorities concerned. If it should be found unsuitable for a particular requirement, the Director of Standardization should be informed of the circumstances. Any enquiries regarding this Section in relation to an invitation to tender or a contract in which it is invoked should be addressed to the Qualification Assurance Authority named in that invitation to tender or contract.

INDEX TO CONTENTS

<u>CLAUSE</u>	<u>TITLE</u>	<u>PAGE</u>
1	SCOPE	3
2	RELATED SPECIFICATIONS AND DOCUMENTS	3
3	INFORMATION TO BE SUPPLIED BY PURCHASER	3
4	ILLUSTRATIONS AND DRAWINGS	3
5	STYLE REFERENCES	4
6	QUALIFICATION APPROVAL	4 - 6
7	BATCH ACCEPTANCE PROCEDURE	6 - 7
8	SYSTEMATIC QUALITY ASSURANCE TESTS	8 - 9
9	TEST REQUIREMENTS	9 - 18
	TABLE I. STANDARD RANGE OF PLUGS AND SOCKETS	19
	RATINGS	20
<u>DRAWINGS AND ILLUSTRATIONS</u>		
	OUTLINE DRAWINGS	22 - 24
	PANEL CUT-OUTS	25 - 26
	CONTACT SIZING AND HOLDING FORCE GAUGES	27
<u>ANNEX</u>		
	NATO ELECTRONICS PARTS RECOMMENDATION	28

SPECIFICATION FOR
PLUGS AND SOCKETS, ELECTRICAL
FOR INTER-CHASSIS CONNECTIONS. (PATTERN 103)

1. SCOPE

a. This specification relates to a range of multicontact, unsealed, rectangular plugs and sockets with size 20 contacts and soldered terminations Pattern 103 plugs and sockets are suitable for making inter-chassis connections. The items specified herein will engage with and can be used as replacements for similar connectors to US specification MIL-C-8384C.

b. This specification gives details of dimensions, ratings, and test values peculiar to the range of standards defined. It is primarily intended for those concerned with components for use in Service equipment. Other users are invited to adopt it if they so desire.

2. RELATED SPECIFICATIONS AND DOCUMENTS

These are listed in Defence Standard DEF STAN 59 - 35(PART 1). Reference is also made to MIL-C-8384C, Plugs and sockets, electrical, Pattern 103.

3. INFORMATION TO BE SUPPLIED BY PURCHASER

a. When ordering components to this Section of the Standard it is essential to quote the relevant NATO Stock Number (where allotted), Style Reference, and to quote this Section of the Standard.

b. Before using the NATO Stock Number given in this Section of the Standard, reference should be made to the Joint Service qualified products list of electronic parts (RCG4) to ascertain that a Qualification Approval Certificate is extant for the item concerned.

4. ILLUSTRATIONS AND DRAWINGS

a. The essential purpose of the illustrations and drawings which form part of this specification is to ensure mechanical interchangeability. It is essential that equipment designers work to the limits stated in the control drawings and not to the dimensions of individual specimens. Where official drawings are quoted they are mandatory. Copies of such drawings are obtainable from Ministry of Aviation Supply, EQD, Section T2(d), Aquila, Golf Road, Bromley, Kent. BRI 2JB.

b. HM Government drawings referred to are now associated with this Section of the Defence Standard and therefore they must not be altered in any way which will affect function, material, or interchangeability unless the section of the Defence Standard itself is amended. Holders of master drawings must endorse them accordingly.

DEF STAN 59 - 35(PART 1)
SECTION 1(CONTD)

5. STYLE REFERENCES

The style references used in this specification are abbreviations to identify individual plugs and sockets. Typical style references are CC 1514-7P and CC 1514-7S.

CONTROL DRAWING NUMBER	NUMBER OF CONTACTS	CONTACT
CC/C 1514/1	7	PIN
CC/C 1514/2	7	SOCKET

6. QUALIFICATION APPROVAL

- a. Provision of samples. The manufacturer shall submit specimens in accordance with Schedule 1 for which approval is desired.
- b. Grouping of specimens. The specimens shall be grouped as indicated in Schedule 1.
- c. Test incidence. Initial measurements referred to in Table 4 of DEF - 5011 and in this specification as GROUP 0 shall be carried out immediately prior to the commencement of tests on subsequent groups and the tests shall be recorded. Each test shall be applied in the order listed in Schedule 6 and where measurements are required the results shall be recorded. Where tests are not applicable this is indicated in Schedule 6.

SCHEDULE 1

COLUMN NUMBER		1	2
STYLE REFERENCE OF SPECIMENS		CC/1514-7P CC/1514-7S CC/1519-50P CC/1519-50S	CC/1515-14P CC/1515-14S CC/1516-18P CC/1516-18S CC/1517-26P CC/1517-26S CC/1518-34P CC/1518-34S
TOTAL MATING PAIRS OF EACH VARIANT		(a) 18	(b) 4
GROUP	TEST NO	DISTRIBUTION OF SPECIMENS (Mating pairs)	
0	15.1 to 15.11 except 15.1(iii) (See Note 2) 15.6, 15.8, 15.10 15.36 (See Note 3)	All Nil	All Nil
1	15.12 to 15.20 15.15, 15.16, 15.20	4 NOT APPLICABLE	2 NOT APPLICABLE
2	15.21	4	Nil
3	15.22 to 15.24	4	2
4	15.25	NOT APPLICABLE	
5	15.26	2	Nil
6	15.27 15.28	2 NOT APPLICABLE	Nil NOT APPLICABLE
7	15.29, 15.30 15.31 to 15.33	2 NOT APPLICABLE	Nil NOT APPLICABLE
8	15.34 15.35	NOT APPLICABLE	

DEF STAN 59 - 35(PART 1)
SECTION 1(CONTD) - SCHEDULE 2

Notes:

1. a. Qualification Approval submission shall consist of 18 mating pairs of each size (number of contacts) for which approval is required. Where approval is required for a range of more than two sizes the submission shall comprise of 18 mating pairs of each of the largest and smallest sizes together with 4 mating pairs of each other size within the range for which approval is sought.

b. Any departure from the requirements of Schedule 1 shall be agreed with the Approval Authority.
2. Three additional specimens of each variant shall be submitted in the form of piece parts for the dimensional examination of 15.1(iii). Where common piece-parts are involved no more than three specimens of each such part need be submitted.
3. Twenty pin contacts to be supplied as applicable for test 15.36 contact strength.

7. BATCH ACCEPTANCE PROCEDURE

Components submitted for acceptance shall be tested in accordance with DEF-5001-C, Section 3, and shall be subjected to the following tests:

- a. 100 per cent acceptance tests. (See DEF-5001-C, Section 3.)

SCHEDULE 2

TEST NO. DEF STAN 59 - 35 (PART 1)	TITLE OF TEST
15.1(i)	Visual examination
15.11	Voltage proof (Method A)

- b. Sampling tests. (See DEF-5001-C, Section 5.)
 - (1) Tests bracketed together in a group are considered as a sequence and must be performed as such, using the same sample throughout.
 - (2) Information on the re-submission of rejected batches is given in BS 9001.

c. Group A tests.

SCHEDULE 3

TEST NO DEF STAN 59 - 35 (PART 1)	TITLE OF TEST	AQL	INSPECTION LEVEL	TEST CATEGORY
15.2	Compatibility (gauging) or Compatibility Assurance Test (see note below)	1%	II	Non- destructive
15.4	Engagement and disengagement			Non- destructive
15.5	Contact holding force (without sizing)			Non- destructive

Notes:

1. Where compatibility gauges (Test 15.2) are not available a Compatibility Assurance Test shall be applied. For the Compatibility Assurance Test the manufacturer shall demonstrate to the Quality Assurance Authority that his system of piece-part checking and assembly methods together with final mechanical measurements will ensure that the finished component will meet the compatibility requirements.
2. The Inspection Levels and AQL will be agreed by the Quality Assurance Authority in relation to each particular manufacturer's system.

d. Group B tests.

SCHEDULE 4

TEST NO DEF STAN 59 - 35 (PART 1)	TITLE OF TEST	AQL	INSPECTION LEVEL	TEST CATEGORY
15.12	Soldering	4%	S3	Destructive
15.5	Contact holding force			
15.7	Contact resistance			
15.9	Insulation resistance			
15.30	Contact retention (in insert)			

DEF STAN 59 - 35(PART 1)
SECTION 1(CONTD) - SCHEDULE 5

8. SYSTEMATIC QUALITY ASSURANCE TESTS

Tests bracketed together within a group are considered as a sequence and must be performed as such using the same sample throughout.

a. Group C tests.

SCHEDULE 5

TEST NO DEF STAN 59 - 35 (PART 1)	TITLE OF TEST	AQL	INSPECTION LEVEL	TEST CATEGORY
15.1(ii)	Dimensions (outline). Additionally, issue number of manufacturer's drawing schedule to be checked against that quoted on approval certificate. Any significant changes to be reported to Approval Authority	1%	S3	Non- destructive
15.7	Contact resistance			
15.17	Temperature, rapid change 15.17(i), (ii) and (iii) not required			
15.21	Long term, damp heat (21 days)			
15.21(i)	Working voltage application	4%	S3	Destructive
15.21.2(i)	Contact resistance			
15.21.2(iii)	Insulation resistance			
15.21.2(iv)	Visual examination			
15.21.2(v)	Engagement and disengagement			
15.21.2(vii)	Voltage proof			
15.4	Engagement and disengagement			
15.7	Contact resistance			
15.22	Endurance, mechanical (50 operations)			
15.22(i)	Visual examination			
15.22(ii)	Engagement and disengagement	4%	S3	Destructive
15.22(iii)	Contact holding force			
15.23.1	Endurance high Temperature (500 hours)			
15.23.1(ii)	Insulation resistance (hot)			
15.23.1(iii)	Contact resistance			
15.23.1(v)	Voltage proof			

8 (b. Group D tests

- (1) The sample size and performance requirements for Group D tests shall be in accordance with the Qualification Approval requirements for tests specified in DEF STAN 59-35.
- (2) Components for Group D tests shall be selected from batches which have successfully passed the acceptance tests and the batch size from which this selection is made shall be at least three times the required sample quality.

9. TEST REQUIREMENTS

The general test requirements are fully defined in DEF STAN 59-35(PART 1) The following Table contains additional information on test conditions and requirements for the range of standards defined herein.

SCHEDULE 6

TEST NO DEF STAN 59-35 (PART 1)	TITLE	DESCRIPTION	REQUIREMENTS
15.1	GENERAL EXAMINATION	As specified	As specified
(i)	Visual examination	As specified	As specified
(ii)	Dimensions (outline)	As specified	As specified
(iii)	Dimensions (detail) and materials	As specified	As specified
(iv)	Weight	As specified	As in Table 1
15.2	COMPATIBILITY ASSURANCE	As specified	As specified
15.3	POLARIZATION	As specified	As specified
(i)	Polarizing device	As specified	As specified

DEF STAN 59-35(PART 1)
SECTION 1 SCHEDULE 6(CONTD)

TEST NO DEF STAN 59-35 (PART 1)	TITLE	DESCRIPTION	REQUIREMENTS	
15.3	POLARIZATION (contd)			
(ii)	Mis-mating	As specified	As specified	
(iii)	Orientation	NCT APPLICABLE		
15.4	ENGAGEMENT AND DISENGAGEMENT FORCE	As specified	Engagement and disengagement forces	
		Number of contacts	Max .	Min .
		7	27N(6 lbf)	10N (2.3 lbf)
		14	59N(13 lbf)	17N (4 lbf)
		18	81N(18 lbf)	22N (5 lbf)
		26	122N(25 lbf)	31N (7 lbf)
		34	135N(30 lbf)	40N (9 lbf)
		50	188N(42 lbf)	58N (13 lbf)
			Approx force in lb in brackets)	
15.5	CONTACT HOLDING FORCE	As specified for sizing tool and gauge (see page 27)	As specified	
15.6	SEALING	NOT APPLICABLE		
15.7	CONTACT RESISTANCE	As specified	Maximum - 5 miliohms	
15.8	SHELL CONTINUITY	NOT APPLICABLE		
15.9	INSULATION RESISTANCE	As specified - Method A	Not less than 5 000 megohms	
15.10	IONIZATION	NOT APPLICABLE		

TEST NO DEF STAN 59-35 (PART 1)	TITLE	DESCRIPTION	REQUIREMENTS
15.11	VOLTAGE PROOF	As specified - Method A (See Ratings Table)	As specified
15.12	SOLDERING	Soldering iron method. Bit size 3.175 mm (0.125 in) Recovery time 1 hour	Satisfactory tinning. No loosening of parts or other damage such as would impair performance
15.13	BUMPING	As specified Under 'Atmospheric conditions for measurement' As in 15.7	Maximum intermittency 10 microseconds
(i)	Contact resistance		Maximum - 5 milliohms
(ii)	Sealing	NOT APPLICABLE	
15.14	VIBRATION	As specified Under 'Atmospheric conditions for measurement' Severity V2	Maximum intermittency 10 microseconds
(i)	Contact resistance	As in 15.7	Maximum - 5 milliohms
(ii)	Sealing	NOT APPLICABLE	
15.15	SHOCK	NOT APPLICABLE	
15.16	ACCELERATION	NOT APPLICABLE	
15.17	TEMPERATURE, RAPID CHANGE	As specified Severity T5	As specified
(i)	Contact resistance	As 15.7	Maximum Initial reading plus 5 milliohms
(ii)	Shell continuity	NOT APPLICABLE	
(iii)	Sealing	NOT APPLICABLE	

DEF STAN 59-35(PART 1)
SECTION 1 SCHEDULE 6(CONTD)

TEST NO DEF STAN 59-35 (PART 1)	TITLE	DESCRIPTION	REQUIREMENTS
15.18	CLIMATIC	As specified at H6	As specified
15.18.1	Intermediate measurements	As specified	As specified
(i)	Visual examination	As specified	As specified
15.18.2	Temperature, dry heat	As specified	As specified
(i)	Sealing(hot)	NOT APPLICABLE	
15.18.3	Damp heat, accelerated	As specified	As specified
15.18.4	Temperature, dry cold	As specified	As specified
(i)	Disengagement and engagement (cold)	As specified (Measurement of force is not required)	By hand or by special tool
(ii)	Sealing (cold)	NOT APPLICABLE	
15.18.5	Air density low	As specified at severity D1 and 44 mb at 20°C 20 000 m (66 000 ft)	As specified
(i)	Voltage proof	As specified - Method A (See Ratings Table)	As specified
15.18.6(a)	Damp heat, accelerated with assisted recovery (Class H3 only)	NOT APPLICABLE	
15.18.6(b)	Damp heat, accelerated with 24 hour recovery (Class H5 only)	NOT APPLICABLE	
15.18.6(c)	Damp heat, accelerated (Class H6 only)	As specified	As specified
(i)	Working voltage application	As specified - (See Ratings Table)	As specified

TEST NO DEF STAN 59-35 (PART 1)	TITLE	DESCRIPTION	REQUIREMENTS
15.18.6(d) (Contd)	Damp heat, accelerated with temperature, dry cold. (Class H7 only)		NOT APPLICABLE
15.18.7	Final examination		
(i)	Contact resistance	As in 15.7	Maximum initial reading + 5 milliohms
(ii)	Shell continuity		NOT APPLICABLE
(iii)	Insulation resistance	As in 15.9, Method A, within 30 minutes after completion of recovery	Minimum - 100 megohms
(iv)	Visual examination	As specified	As specified
(v)	Disengagement and engagement	As specified	By hand or by special tool.
(vi)	Sealing		NOT APPLICABLE
(vii)	Insulation resistance (Class H5 only)	As in 15.9 Method A	Minimum - 100 megohms
(viii)	Voltage proof	As specified - Method A (See Ratings Table)	As specified
15.19	FIRE RISK	As specified	As specified
15.20	FIREPROOFNESS		NOT APPLICABLE

DEF STAN 59-35(PART 1)
SECTION 1 SCHEDULE 6(CONTD)

TEST NO DEF STAN 59-35 (PART 1)	TITLE	DESCRIPTION	REQUIREMENTS
15.21	DAMP HEAT, (long term)	As specified Severity H6	As specified
(i)	Working voltage application (omitted for Class H3)	As specified - (See Ratings Table)	As specified
15.21.1(a)	Assisted recovery (Class H3 only)	NOT APPLICABLE	
15.21.1(b)	Recovery (Class H5 only)	NOT APPLICABLE	
15.21.1(c)	Recovery (Class H6 and H7 only)	As specified	As specified
15.21.2	Final measurements		
(i)	Contact resistance	As in 15.7	Initial reading + 5 milliohms
(ii)	Shell continuity	NOT APPLICABLE	
(iii)	Insulation resistance	As in 15.9 Method A	Minimum - 100 megohms
(iv)	Visual examination	As specified	As specified
(v)	Disengagement and engagement	As specified	By hand or by special tool
(vi)	Sealing	NOT APPLICABLE	
(vii)	Insulation resistance (Class H5 only)	NOT APPLICABLE	
(viii)	Voltage proof	As specified - Method A (See Ratings Table)	As specified

TEST NO DEF STAN 59-35 (PART 1)	TITLE	DESCRIPTION	REQUIREMENTS
15.22	ENDURANCE, MECHANICAL	As specified 500 operations under 'Atmospheric' conditions for measurement	Maximum speed 15 operations per minute
(i)	Visual examination	As specified	As specified
(ii)	Engagement and disengagement	As in 15.4	By hand or by special tool
(iii)	Contact holding force	As in 15.5(less sizings) For sizing tool and gauge see page 27	As specified
15.23	ENDURANCE HIGH TEMPERATURE (long and short term)	As specified (all specimens long term only)	-
15.23.1	Long term (all specimens)	All contacts to be linked in series with short lengths of suitable conductor. Ambient temperature 125°C. For current see Ratings Table	-
(i)	Sealing(hot)		NOT APPLICABLE
(ii)	Insulation resistance (hot)	As in 15.9 Method A	Minimum - 100 megohms
(iii)	Contact resistance	As in 15.7	Maximum - initial reading plus 5 milliohms
(iv)	Shell continuity		NOT APPLICABLE
(v)	Voltage proof	As specified - Method A (See Ratings Table)	As specified
(vi)	Sealing		NOT APPLICABLE
15.23.2	Short term		NOT APPLICABLE

DEF STAN 59-35(PART 1)
SECTION 1 SCHEDULE 6(CONTD)

TEST NO DEF STAN 59-35 (PART 1)	TITLE	DESCRIPTION	REQUIREMENTS
15.24	PLATING PROVING	Specimens to be tested unmated as specified	-
(i)	Preliminary	As specified	-
(ii)	Contact resistance	As in 15.7	Maximum initial reading plus 5 milliohms
(iii)	Insulation resistance	As in 15.9 Method A	Minimum - 100 megohms
(iv)	Engagement/disengagement forces	As in 15.4	By hand or special tool
15.25	SHELF LIFE	NOT APPLICABLE	
15.26	MOULD GROWTH	As specified	-
(i)	Insulation resistance	As in 15.9 Method A	Minimum - 100 megohms
(ii)	Visual examination	As specified	As specified
15.27	SALT MIST	As specified	-
(i)	Contact resistance		NOT APPLICABLE
(ii)	Shell continuity		NOT APPLICABLE
(iii)	Engagement/disengagement force		NOT APPLICABLE
(iv)	Insulation resistance		NOT APPLICABLE
(v)	Working voltage application		NOT APPLICABLE
		The specimens shall then be 'Cleaned after exposure' and subjected to the following test:	

TEST NO DEF STAN 59-35 (PART 1)	TITLE	DESCRIPTION	REQUIREMENTS
(vi) (Contd)	Visual examination	As specified The specimens shall be allowed 'Recovery after cleaning' and shall then be sub- jected to the following tests:	As specified
(vii)	Disengagement and engagement	As specified	By hand or by special tool
(viii)	Insulation resistance	As in 15.9, Method A	Minimum - 100 megohms
(ix)	Contact resistance	As in 15.7	Maximum - initial reading plus 5 milliohms
(x)	Shell continuity	NOT	APPLICABLE
(xi)	Voltage proof	As specified - Method A (See Ratings Table)	As specified
15.28	DJUST	NOT	APPLICABLE
15.29	ROBUSTNESS OF TERMINATIONS	As specified Test 50% of the contacts but not more than 6 Applied force 9N (2 lb approx)	As specified
15.30	CONTACT RETENTION (in insert)	As specified Test 50% of the contacts but not more than 6 (samples to be different from those tested in 15.29) Applied force 44N(10 lb approx)	As specified
15.31	INSERT RETENTION (Shell)	NOT	APPLICABLE
(i)	Sealing	NOT	APPLICABLE

DEF STAN 59-35 (PART 1)SECTION 1SCHEDULE 6 (CONTD)

TEST NO DEF STAN 59-35 (PART 1)	TITLE	DESCRIPTION	REQUIREMENTS
15.32	TEST PROD DAMAGE	NOT APPLICABLE	
15.33	IMPACT AND RESISTANCE TO STATIC LOAD	NOT APPLICABLE	
15.34	IMMERSION	NOT APPLICABLE	
15.35	SOLVENT RESISTANCE	NOT APPLICABLE	
15.36	CONTACT STRENGTH size 20 (1 mm dia)	As specified Load 0.9 kg \pm 0.03 kg (2 lb \pm 1 oz) using fixture	Permanent set not to exceed 0.127 mm (0.005 in)

LINE NO	STYLE REFERENCE	NATO STOCK NO	ITEM NAME	NO OF CONTACTS	MAXIMUM WEIGHT GRAMES
	(a)	(b)	(c)	(d)	(e)
1	CC 1514-7P	013-0277	PLUG ELECTRICAL	7	8.5
2	CC 1514-7S	013-0278	SOCKET ELECTRICAL	7	8.5
3	CC 1515-14P	013-0279	PLUG ELECTRICAL	14	11.5
4	CC 1515-14S	013-0280	SOCKET ELECTRICAL	14	11.5
5	CC 1516-18P	013-0281	PLUG ELECTRICAL	18	14.5
6	CC 1516-18S	013-0282	SOCKET ELECTRICAL	18	14.5
7	CC 1517-26P	013-0283	PLUG ELECTRICAL	26	17.5
8	CC 1517-26S	013-0284	SOCKET ELECTRICAL	26	14.5
9	CC 1518-34P	013-0285	PLUG ELECTRICAL	34	26.0
10	CC 1518-34S	013-0286	SOCKET ELECTRICAL	34	20.0
11	CC 1519-50P	013-0287	PLUG ELECTRICAL	50	28.5
12	CC 1519-50S	013-0288	SOCKET ELECTRICAL	50	28.5

PLUGS AND SOCKETS, ELECTRICAL

STANDARD RANGE

TABLE 1

DEF STAN 59-55(PART 1)
SECTION 1
TABLE 1

DEF STAN 59-35(PART 1)

SECTION 1

RATINGS - TABLES A & B

RATINGS

Temperature Severity T5 (-55/+ 125°C)

Humidity Severity H6

General purpose Class 1 (Low air density D1 and 20 000 metres 66 000 ft).

CURRENT

The ratings are for ambient temperatures not exceeding 125°C with all contacts carrying the specified current. For operation at the maximum ratings contacts must be connected with wire of adequate size so there is no temperature gradient causing heat to flow into the contacts.

TABLE A

STYLE REFERENCE	CURRENT PER CONTACT AMPERES
CC/C 1514-7P CC/C 1514-7S	7
CC/C 1515-14P CC/C 1515-14S	5
CC/C 1516-18P CC/C 1516-18S	4.5
CC/C 1517-26P CC/C 1517-26S	4.0
CC/C 1518-34P CC/C 1518-34S	3.5
CC/C 1519-50P CC/C 1519-50S	3.0

VOLTAGE

TABLE B

APPLICATION	ALTITUDE		
	SEA LEVEL	9 144 METRES(D1) (30 000 ft)	20 000 METRES (66 000 ft)
Working d.c.	750 Volts	500 Volts	175 Volts
Working a.c. r.m.s. 45-60 Hz	500 Volts	350 Volts	125 Volts
Proof d.c. or a.c. peak	2 500 Volts	1 000 Volts	525 Volts

OUTLINE DRAWINGS

DEF STAN 59-35(PART 1)
SECTION 1

No 4 (-112) 40 UNC-2A
FOR GUIDES 'X' & 'Y' ON
ENTIRE RANGE

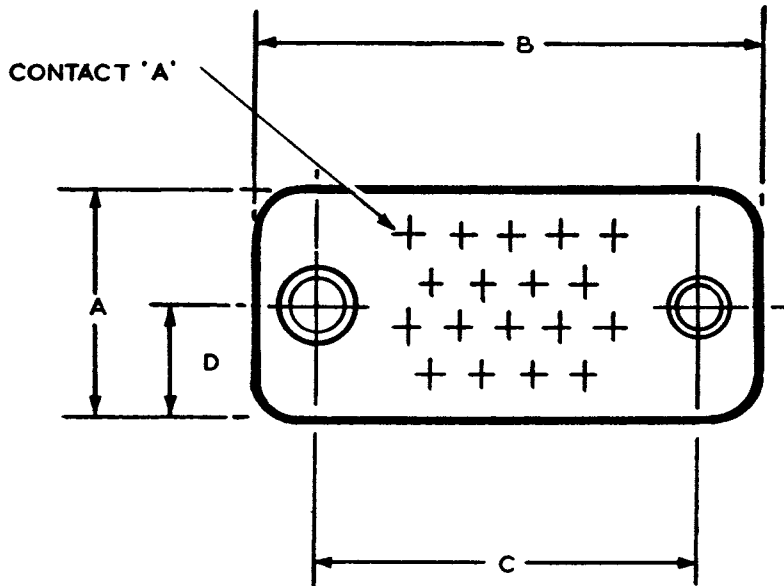
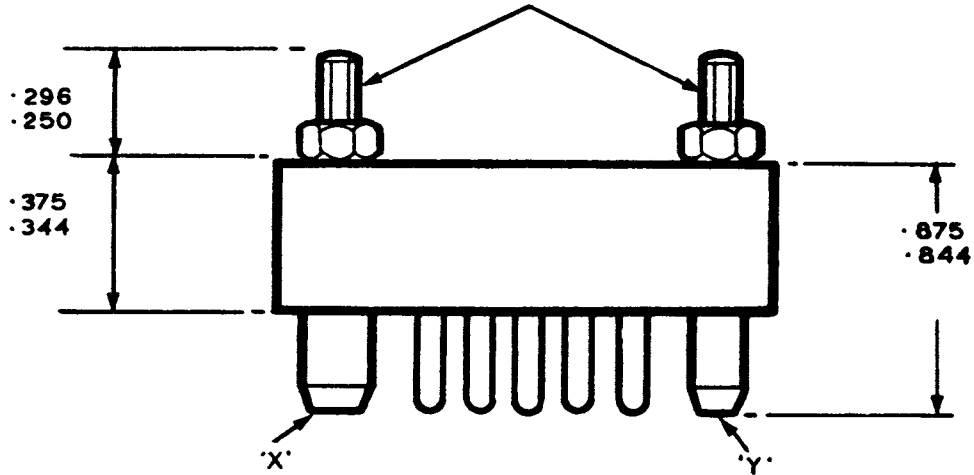

DIMENSIONS (IN INCHES)

NO. OF WAYS	A	B	C	D
7	0.380	1.220	0.906	0.190
14	0.440	1.250	0.937	0.220
18	0.560	1.310	1.000	0.280
26	0.560	1.630	1.312	0.288

PLUGS - 7, 14, 18 and 26 Contacts

Note: On all ranges under normal mating conditions the two mouldings should meet and the distance between the two mounting faces will be 0.710-0.750 in.

OUTLINE DRAWINGS

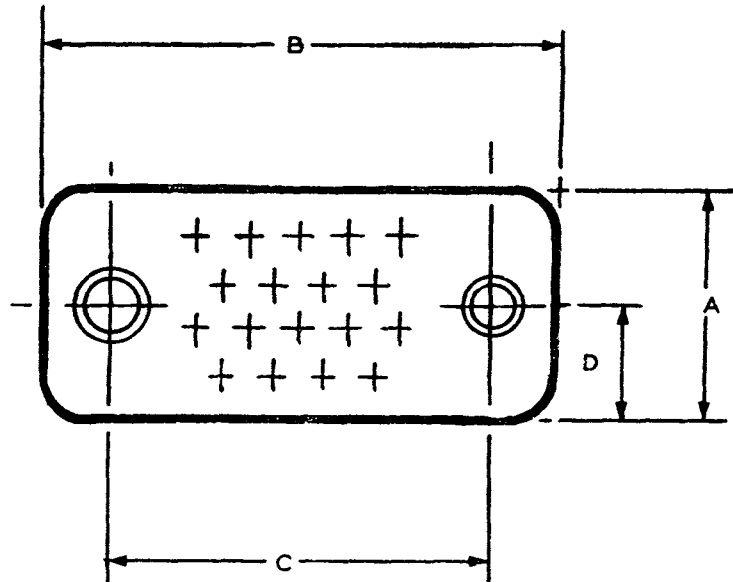
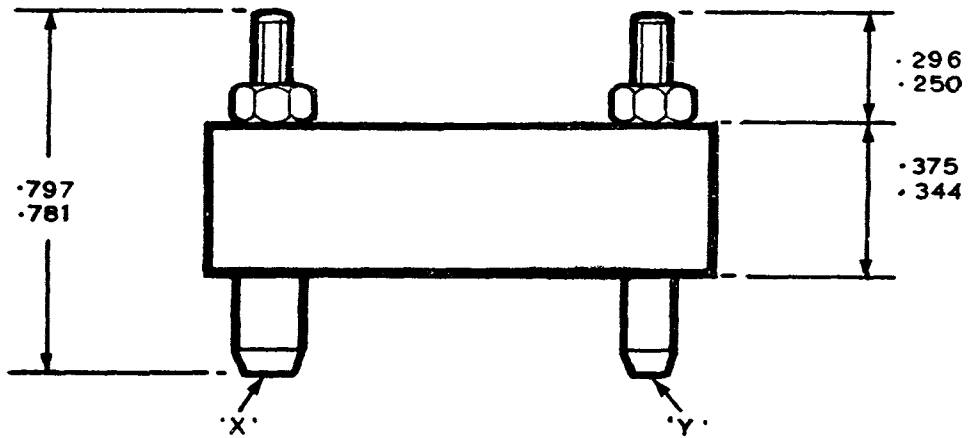

DIMENSIONS (IN INCHES)

NO. OF WAYS	A	B	C	D
7	0.380	1.220	0.706	0.190
14	0.440	1.250	0.737	0.220
18	0.560	1.310	1.000	0.280
26	0.560	1.630	1.312	0.288

SOCKETS - 7, 14, 18 and 26 Contacts

OUTLINE DRAWINGS

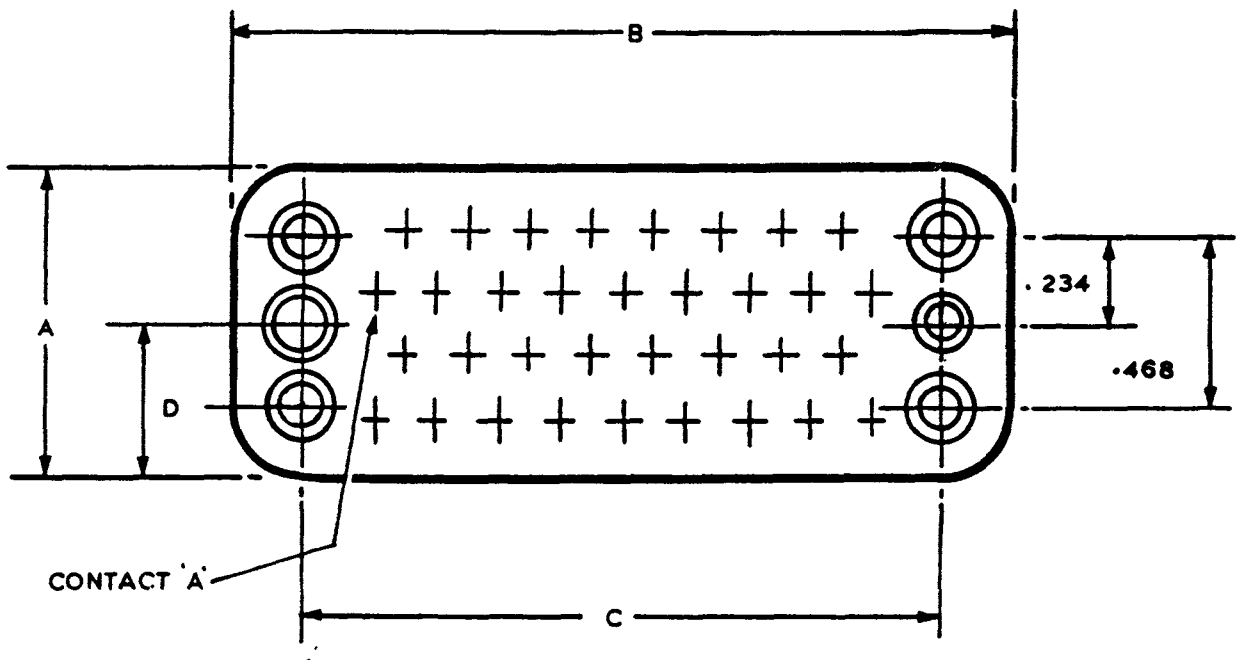
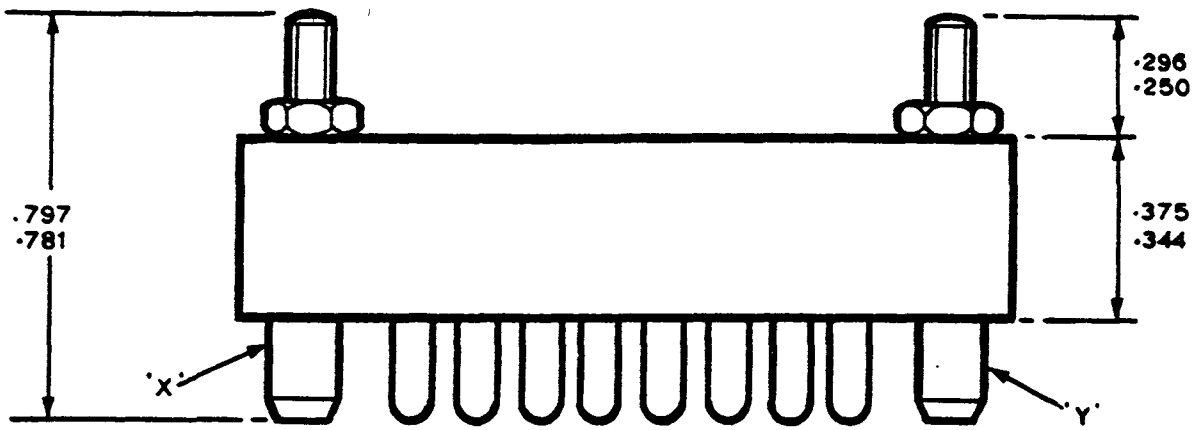

DIMENSIONS (IN INCHES)

NO. OF WAYS	A	B	C	D
34	0.750	2.000	1.687	0.375
50	0.875	2.720	2.282	0.438

PLUGS - 34 and 50 Contacts

OUTLINE DRAWINGS

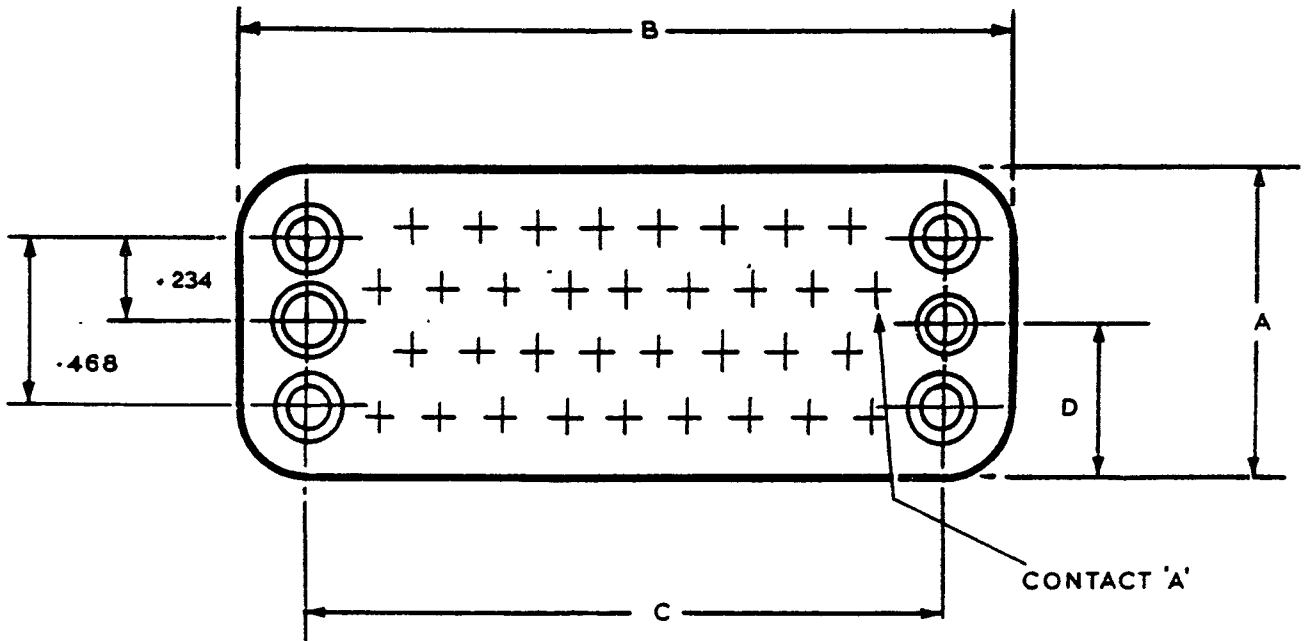

DIMENSIONS (IN INCHES)

NO. OF WAYS	A	B	C	D
34	0.750	2.000	1.687	0.375
50	0.875	2.270	2.282	0.438

SOCKETS - 34 and 50 Contacts

(Amdt 1)

PANEL CUTOUTS

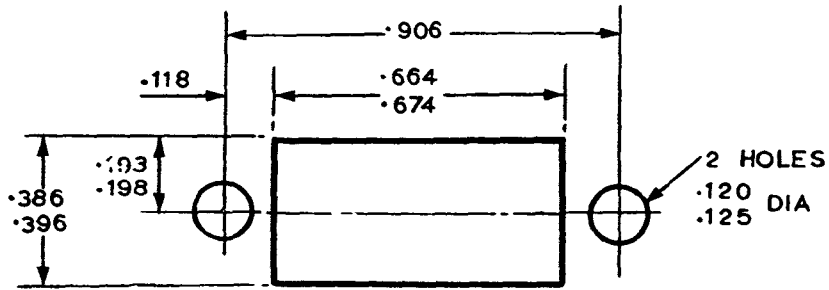

PLUGS AND SOCKETS - 7 Contacts

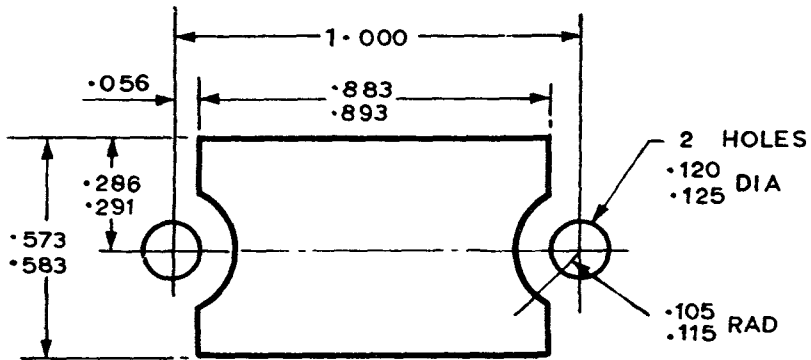

PLUGS AND SOCKETS - 18 Contacts

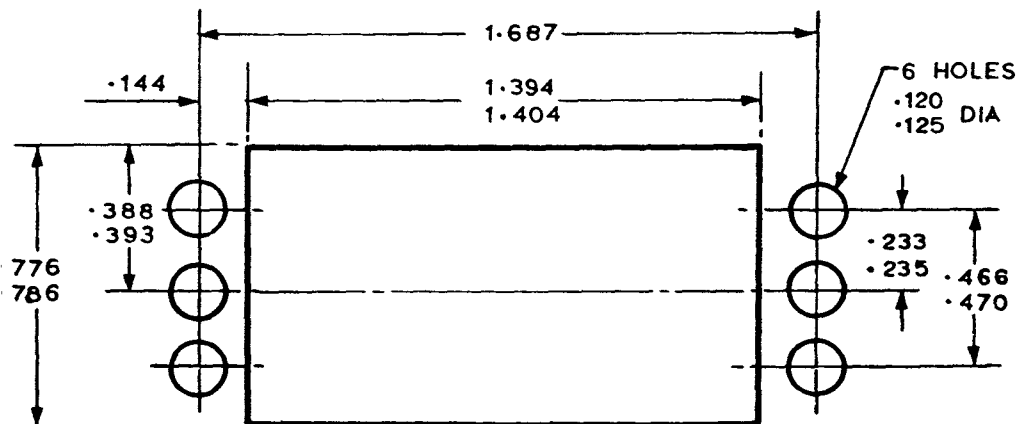

PLUGS AND SOCKETS - 34 Contacts

PANEL CUTOUTS

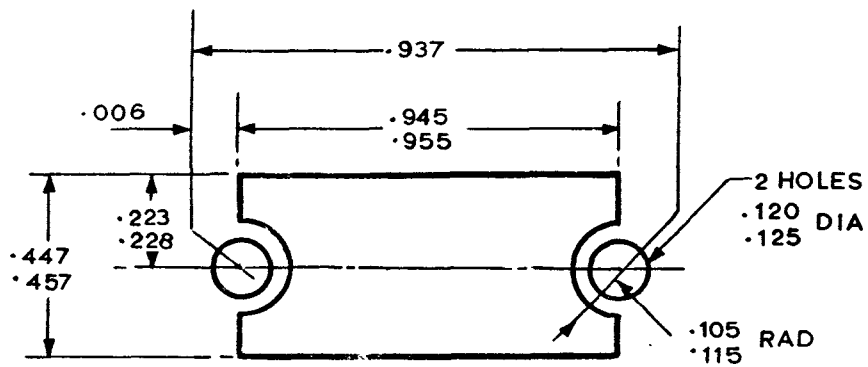

PLUGS AND SOCKETS - 14 Contacts

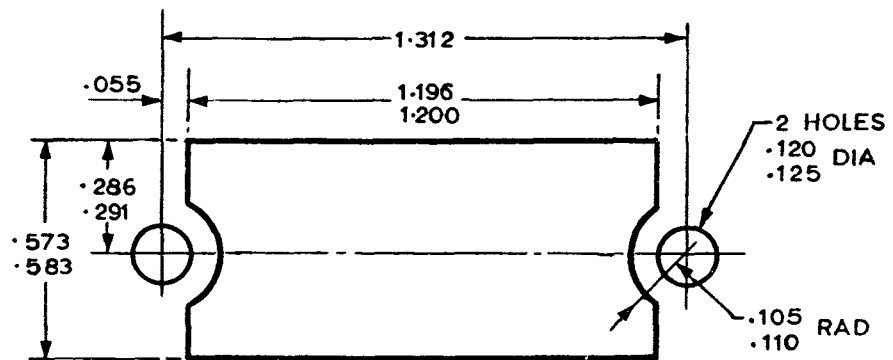

PLUGS AND SOCKETS - 26 Contacts

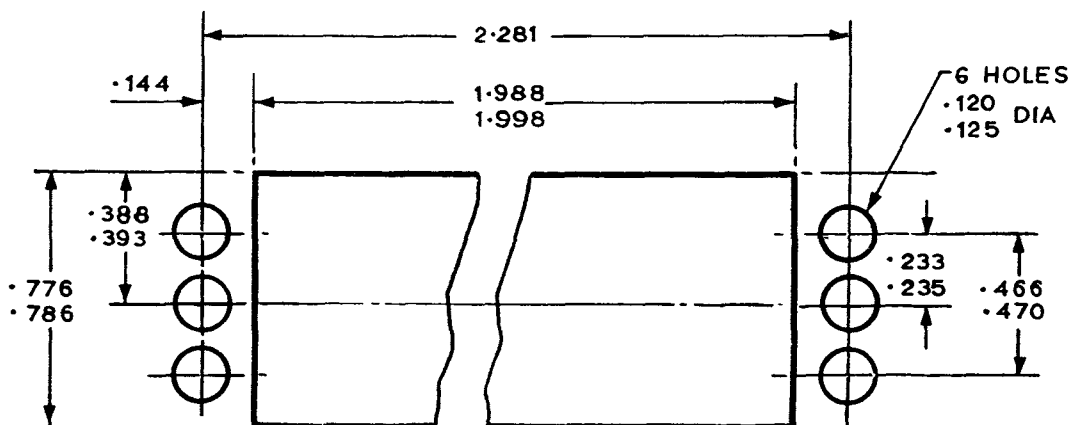

PLUGS AND SOCKETS - 50 Contacts

CONTACT SIZING AND HOLDING FORCE GAUGES

PLUGS AND SOCKETS, ELECTRICAL, PATTERN 103

APPENDIX

Contact sizing and holding force gauges

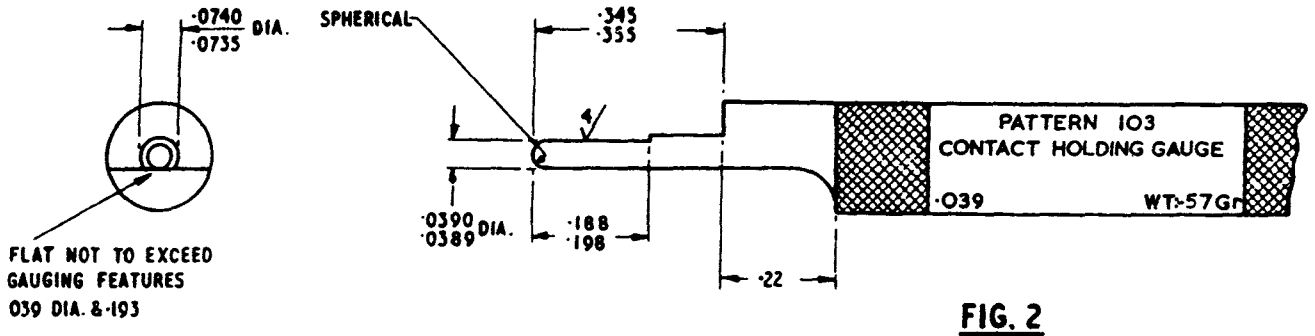
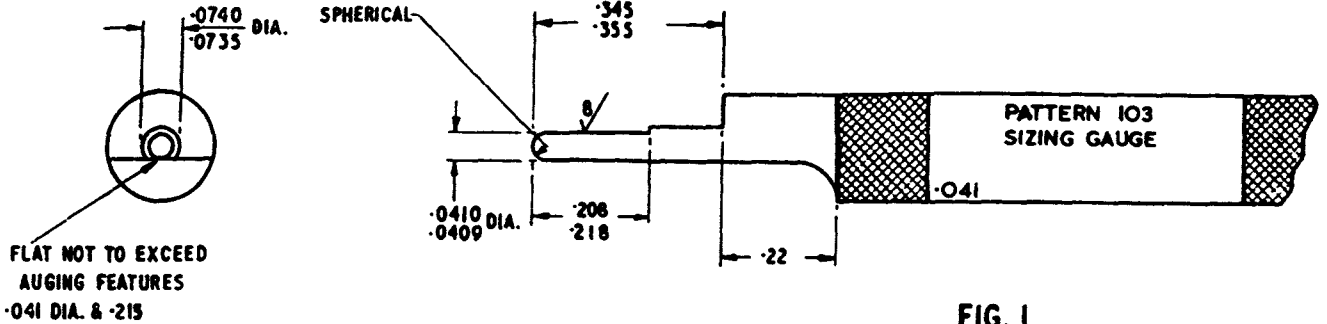

- Notes:
1. Gauging features to be hardened ✓ = harden, temper, grind and lap 650 HV20.
 2. Material: Gauge steel. All sharp edges to be removed.
 3. These gauges are to be used for testing fully assembled component only.

NATO ELECTRONICS PARTS RECOMMENDATION NO 30 (SECOND REVISION)

STANDARDIZATION OF MULTICONTACT CONNECTORS ELECTRIC,
RECTANGULAR, MOULDED-BODY

GENERAL SUMMARY

1. The multicontact connectors electric, rectangular, moulded-body defined herein are recommended by the NATO Group of Experts on Electronic Parts for use in new designs of equipment for the Armed Forces of the North Atlantic Treaty Organization.

PLUGS AND SOCKETS, ELECTRICAL, PATTERN 104,
SEALED, WITH SOLDERED TERMINATIONS AND
THREADED COUPLING, FOR D.C. AND LOW
FREQUENCY APPLICATIONS

AMENDMENT 1

1. Cancel existing pages: 3,4,5,6,9,76,77,80,81,84,85,86,88 and 89
Substitute new pages: 3,4,5,6,9,76,77,80,81,84,85,86,88 and 89
2. Page 1, clause 3; Amend to read: 3.a.
Insert new clause 3.b as follows: b. Tables II, 'Items permitted only for maintenance purposes' and Tables III, 'Items no longer to be provisioned', are contained in Defence Standard 59-4(PART 4).
3. Page 2, INDEX TO CONTENTS, under column headed TITLE
 - a. Line 2, Delete: SPECIFICATIONS AND
 - b. Line 4, Delete: PURPOSE OF
 - c. Line 6, Delete: PROCEDURE FOR
 - d. Line 13, after ELECTRICAL
Insert: ,PATTERN 104
4. Page 7, Delete all detail
5. Page 12, SCHEDULE 7, against TEST NO 15.12, under column headed DESCRIPTION
Delete: 3.175 mm and 3A
Substitute: 3 mm and 3.5A
6. Page 37, TABLE I(c) - CONTINUED, column 4 headed 2-6, under NATO STOCK NO
Delete: 5035-99
Substitute: 5935-99
7. Page 49, TABLE I(G), column 5 heading
Delete: 1-5
Substitute: 1-6
8. Page 78,
 - a. column 2, headed No OF CONTACTS AND CURRENT RATING, line 10
Delete: 4 (1x60 AMP)
4 (3x19 AMP)
Substitute: 4 (3x60 AMP)
4 (1x19 AMP)

8. Page 78, (contd)

b. Columns 4 and 6, headed BUSHING RUBBER (1) and (2), under NATO STOCK NUMBER

Delete: 5340-99

Substitute: 5365-99

c. Column 5, headed SHIELD ELECTRICAL PLUG-SOCKET ANGLED

Delete NATO Stock Nos: 014-2975 (twice), and 014-2978

Substitute NATO Stock Nos: 014-2977 (twice), and 014-1974

d. Column 6, headed BUSHING RUBBER (2)

Delete NATO Stock Nos: 014-9210, and 014-9211

Substitute NATO Stock Nos: 014-9205, and 014-9206 respectively

e. Column 7, headed PACKING PIECE

Delete NATO Stock Nos: 014-9203, 014-9230, and 014-9232

Substitute NATO Stock Nos: 014-9232, 014-9232, and 014-9233 respectively

f. Column 8, headed NUT BUSHING RETAINER

Delete NATO Stock Nos: 014-2969(twice), and 014-2970

Substitute NATO Stock Nos: 014-2970(twice), and 014-2971 respectively

9. Page 79,

a. Column 2, headed No OF CONTACTS AND CURRENT RATING, line 10

Delete: 4^(1x60 AMP)
 4^(3x19 AMP)

Substitute: 4^(3x60 AMP)
 4^(1x19 AMP)

b. Columns 4 and 6, headed BUSHING RUBBER (1) and (2), under NATO STOCK NUMBER

Delete: 5340-99

Substitute: 5365-99

c. Column 5, headed SHIELD ELECTRICAL PLUG-SOCKET STRAIGHT

Delete NATO Stock Nos: 014-2960(twice), and 014-2963

Substitute NATO Stock Nos: 014-2962(twice), and 014-2964 respectively

d. Column 6, headed BUSHING RUBBER (2)

Delete NATO Stock Nos: 014-9210, and 014-9211

Substitute NATO Stock Nos: 014-9205, and 014-9206 respectively

9. Page 79, (contd)

e. Column 7, headed PACKING PIECE

Delete NATO Stock Nos: 014-9203, 014-9230, and 014-9232

Substitute NATO Stock Nos: 014-9232, 014-9232, and 014-9233
respectively

f. Column 8, headed NUT BUSHING RETAINER

Delete NATO Stock Nos: 014-2969(twice), and 014-2970

Substitute NATO Stock Nos: 014-2970(twice), and 014-2971
respectively

10. Page 87, in the tables under NATO STOCK No after 5935-99 in each case

Delete:

097-0052
097-0053
097-0054
097-0055
097-0056
097-0057
097-0255
097-0256
097-0257

Substitute:

013-9172
013-9173
013-9174
013-9175
013-9176
013-9177
013-9178
013-9179
013-9180

11. Make a note of this amendment on the Amendment Record.

25 OCTOBER 1976
DIRECTORATE OF STANDARDIZATION
MINISTRY OF DEFENCE
LONDON

SPECIFICATION FOR PLUGS AND SOCKETS, ELECTRICAL
PATTERN 104, SEALED WITH SOLDERED TERMINATIONS
AND THREADED COUPLING, FOR D.C. AND LOW
FREQUENCY APPLICATIONS

1. SCOPE

a. This specification relates to a range of multi-contact, circular, sealed plugs and sockets, electrical with threaded coupling, silver plated contacts and soldered terminations for dc. and low frequency applications. Pattern 104 plugs and sockets are available in three basic types:

- Type A - Aluminium shells with fine threaded coupling.
- Type B - Brass shells with coarse threaded coupling.
- Type C - Aluminium shells with coarse threaded couplings.

b. Outlets and accessories, which will provide sealing, screening and screen termination for use with the Standard Range of Pattern 104 plugs and sockets are also included in this Standard.

c. This specification gives details of dimensions, ratings, and test values peculiar to the standard range of items defined.

d. The Standard range of pattern 104, plugs and sockets are interchangeable and mateable with appropriate styles, sizes and orientations of the circular multi-contact plugs and sockets shown in Tables II and III, Defence Standard 59-4 Part 4, which superseded DEF 5321. The Pattern 104 Standard Range should first be considered when provisioning, for maintenance purposes, any of the Defence Standard 59-4(PART 4) items.

2. RELATED DOCUMENTS

These are listed in Def Stan 59-35(PART 1).

3. INFORMATION TO BE SUPPLIED BY PURCHASER

a. When ordering components to this section of the Standard it is essential to quote the relevant NATO Stock Number (where allotted), style reference, and this section of the Standard.

b. It is essential that having selected a particular component from the ranges listed in this Standard, reference is made to DEF STAN 59-59 'Services qualified products list of electronic components' to ascertain that a Qualification Approval Certificate is extant for the item concerned. If there is no such certificate at the time of selection, then the relevant NATO Stock Number(s) listed shall not be used.

4. ILLUSTRATIONS AND DRAWINGS

a. The essential purpose of the illustrations and drawings which form part of this specification is to ensure mechanical interchangeability. It is essential that equipment designers work to the limits stated and not to the dimensions of individual specimens. Where official drawings are quoted they are mandatory. Copies of such drawings are obtainable from: Ministry of Defence (PE), EQD, Section T4, 'Aquila', Golf Road, Bromley, BR1 2JB.

b. HM Government drawings referred to are now associated with this Section of the Defence Standard and therefore they must not be altered in any way which will affect function, material, or interchangeability unless the Section of the Defence Standard itself is amended. Holders of master drawings must endorse them accordingly.

5. STYLE REFERENCE

The style reference used to identify individual plug and socket variants are codes representing the following characteristics:

CHARACTERISTIC	CODE	REPRESENTING
Function	P or S	Plug or socket
Pattern	04	Pattern 104
Type	A, B or C	A = Aluminium shell, fine thread coupling B = Brass shell, coarse thread coupling C = Aluminium shell, coarse thread coupling
Temperature severity	4	T4 = -55 to + 100°C
Shell style	C, F or X	C = free female shell (coupler) F = free male shell X = fixed female shell
Shell size	1, 2 or 3	Size of shell
Number of contacts	2, 3, 4 etc as applicable	Number of contacts
Orientation	0 to 5 as applicable	The orientation of the insert in relation to the master Key/keyway of the shell.

Note: A typical style reference is - P 04 A 4 X1-6/0

6. QUALIFICATION APPROVAL

a. Manufacturer's seeking Qualification Approval shall:

- (1) Comply with the requirements of DEF-5001-C.
- (2) Submit a minimum sample of 60 mated pairs of specimens, representative of the range for which approval is sought, for test in accordance with Schedule 1.
- (3) Submit for tests 15.2 and 15.3 an additional 3 specimens of each shell size, type, style, contact arrangement and orientation for which approval is sought. Alternatively, an approved 'sampling plan' may be agreed by the supervising Quality Assurance Authority.
- (4) Submit for tests 15.1 (iii) an additional 3 specimens of each piece part of the range submitted for approval. Where common piece parts are involved, not more than 3 of each need be submitted.

Note: On the satisfactory conclusion of tests on the additional specimens submitted at 6a(3) and (4) above, the specimens may be returned to the manufacturer's stock.

b. Specimens for each Group should contain representative types and styles of the smallest, medium, and largest sizes for which approval is sought. The overall sample (Group 0) shall include the greatest contact density for each voltage and current rating for which approval is sought.

c. Specimens for Groups 1, 2, 3 and 7, shall be taken from the overall sample which shall be submitted for Group 0 tests immediately prior to any other Group of tests.

d. Specimens for Groups 4, 5, and 6, may be taken from the sample used for Group 7.

e. Specimens for Group 8, may be taken from those used for Group 2.

SCHEDULE 1 - PROVISION AND GROUPING OF SAMPLES

GROUP	DEF STAN 59-35/(PART 1) TEST NUMBER	MINIMUM FULL RANGE PER GROUP (mated pairs)	DISTRIBUTION
0	15.1 (except 15.1 (iii)) to 15.11	60	ALL
	15.5		female contacts only
	15.36 (Twenty size 20 contacts to be supplied as applicable)		
1	15.12 to 15.18	15	ALL
	15.19		Mating Item Only 1 Fixed and 1 Free
	15.20		Not applicable
2	15.21	15	ALL
3	15.22 and 15.23	15	ALL
	15.24		Not applicable
4	15.25	5	ALL
5	15.26	5	ALL
6	15.27 and 15.28	5	ALL
7	15.29 to 15.33	15	ALL
8	15.34	11	5
	15.35		1 for each solvent

d. Group 'B' tests.

SCHEDULE 4

TEST NO DEF STAN 59-35 (PART 1)	TITLE OF TEST	AQL	INSPECTION LEVEL	TEST CATEGORY
15.12	Solderability and resistance to heat (DEF 5011, Section 5, test 14g) Bit Size: 3mm for 3amp and 5amp contacts 4.75mm for 19amp contacts 7.62mm for the larger contacts Recovery time 1 hour	4%	S3	Destructive
15.5	Contact holding force			
15.7 \emptyset	Contact resistance			
15.8 \emptyset	Shell continuity			
Note: \emptyset indicates that these tests may be carried out using a test voltage not exceeding 2.5 V and a test current not exceeding 1 amp		4%	S3	Destructive
15.9	Insulation resistance			
15.30	Contact retention (in insert)			
15.31	Insert retention (in shell)	4%	S3	Destructive
15.31(i)	Sealing (excluding panel sealing) The component to be tested in one direction only using pressure differential of 1 bar (1 atmosphere)			

e. Disposal of samples. (See DEF-5001-C, Section 3.)

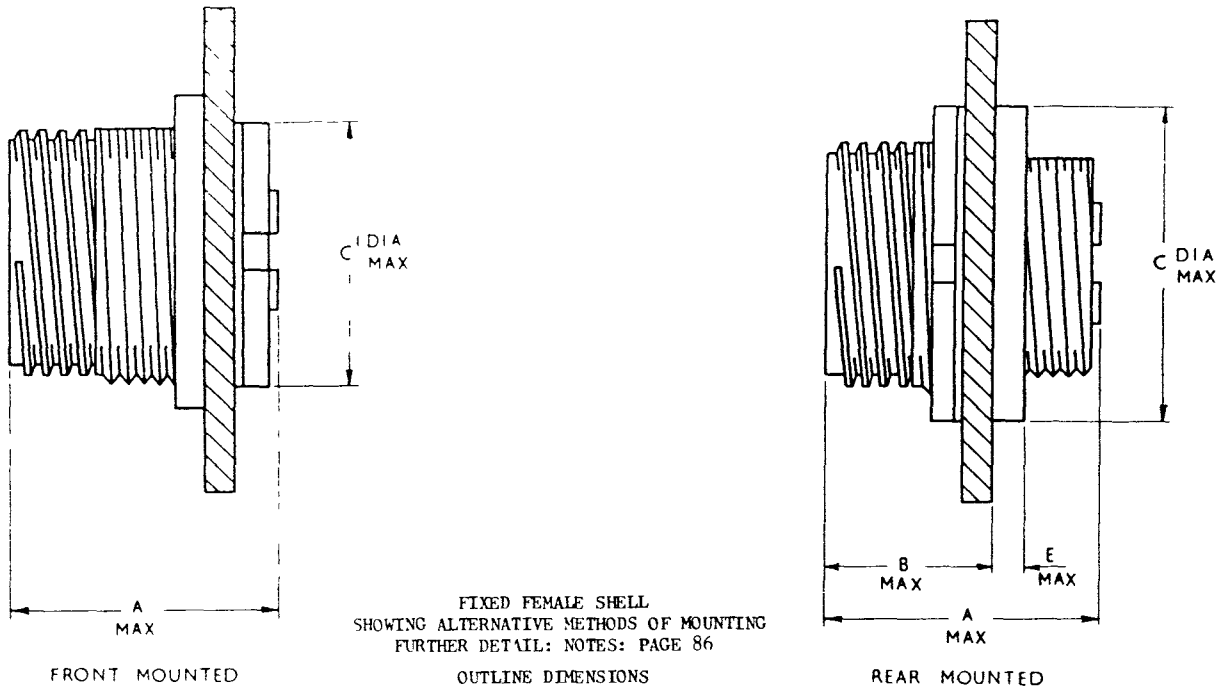

SHELL SIZE	A		B		C		C1		E	
	mm	inch	mm	inch	mm	inch	mm	inch	mm	inch
1	25.05	1.01	15.24	0.600	34.29	1.35	28.70	1.13	3.30	0.130
2	27.60	1.00	17.27	0.680	43.94	1.73	34.29	1.35	3.68	0.145
3	25.96	1.14	17.65	0.695	48.77	1.92	43.94	1.73		

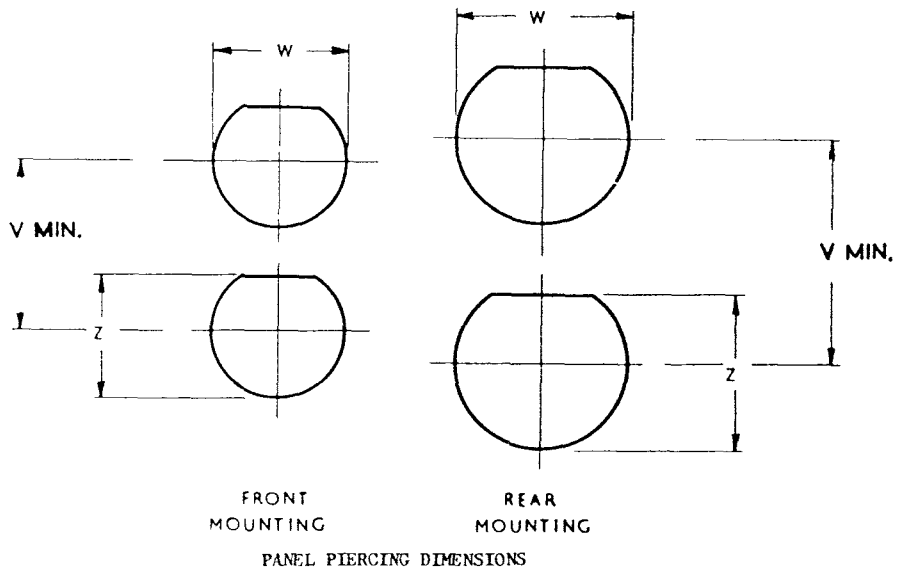

MOUNT -ING	SHELL SIZE	V		W		Z	
		mm	inch	mm	inch	mm	inch
FRONT	1	33.53	1.32	21.53	0.848	20.60	0.811
				21.66	0.853	20.73	0.816
	2	34.68	1.562	27.10	1.067	26.23	1.033
REAR	3			27.23	1.072	26.36	1.038
		50.80	2.00	36.62	1.442	35.81	1.410
	1			36.75	1.447	35.94	1.415
				27.10	1.067	26.23	1.033
				27.23	1.072	26.36	1.038
2	50.80	2.00	36.62	1.442	35.81	1.410	
3	50.80	2.00	36.76	1.447	35.94	1.415	
3				42.42	1.670	41.68	1.641
				42.55	1.675	41.81	1.646

- NOTES: 1. METRIC DIMENSIONS ARE DERIVED FROM ORIGINAL INCH DIMENSIONS
2. MAXIMUM PANEL THICKNESS 3.3 mm (0.13 inch)

PLUG AND SOCKETS, ELECTRICAL, PART 1
 TYPE 1, 2, 3, 4, 5, 6, 7, 8, 9, 10, 11, 12, 13, 14, 15, 16, 17, 18, 19, 20, 21, 22, 23, 24, 25, 26, 27, 28, 29, 30, 31, 32, 33, 34, 35, 36, 37, 38, 39, 40, 41, 42, 43, 44, 45, 46, 47, 48, 49, 50, 51, 52, 53, 54, 55, 56, 57, 58, 59, 60, 61, 62, 63, 64, 65, 66, 67, 68, 69, 70, 71, 72, 73, 74, 75, 76, 77, 78, 79, 80, 81, 82, 83, 84, 85, 86, 87, 88, 89, 90, 91, 92, 93, 94, 95, 96, 97, 98, 99, 100

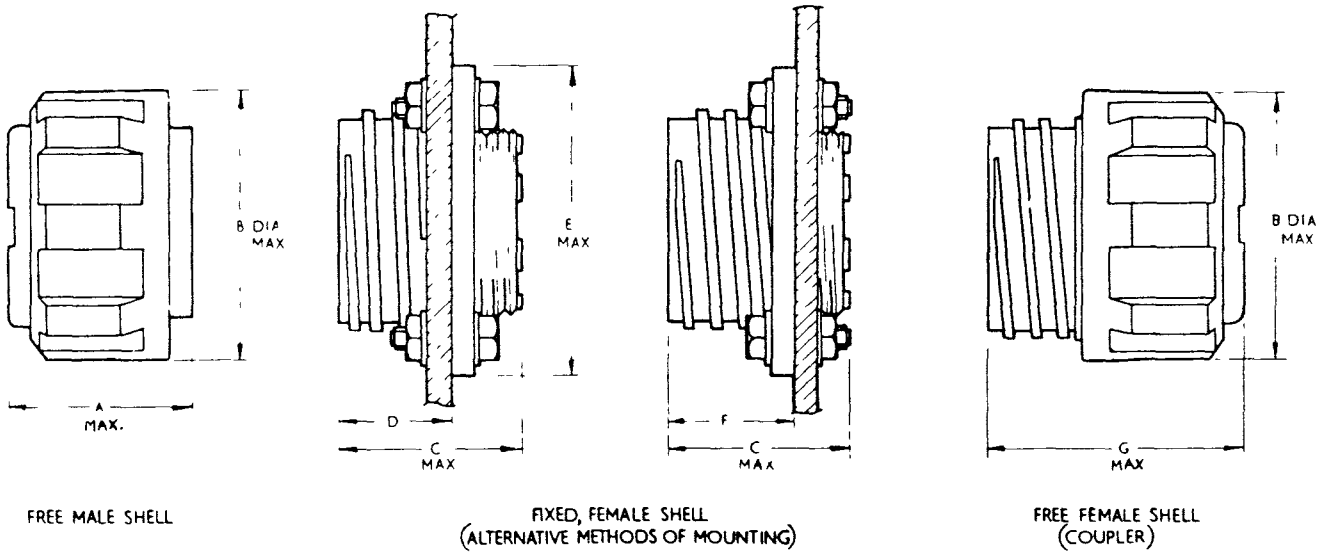
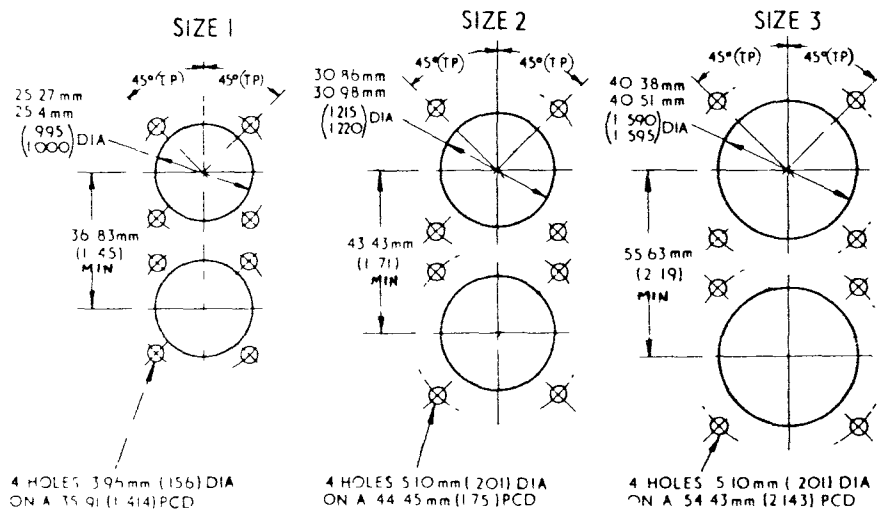

TABLE 1

SIZE	DIMENSIONS													
	A		B		C		D		E		F		G	
	mm	inch	mm	inch	mm	inch	mm	inch	mm	inch	mm	inch	mm	inch
1	26.67	1.05	32.51	1.28	26.67	1.05	16.25	0.64	35.03	1.34	19.55	0.77	30.48	1.20
2	26.67	1.05	38.60	1.52	26.67	1.05	16.25	0.64	42.16	1.66	19.55	0.77	30.48	1.20
3	32.00	1.26	49.02	1.92	29.21	1.15	18.03	0.71	49.02	1.93	21.84	0.86	33.02	1.30

TABLE 2

	SHELL SIZE		
	1	2	3
SPECIAL BOLT	4BA $\frac{1}{2}$	2BA $\frac{5}{8}$	2BA $\frac{3}{4}$
WASHER FLAT	4BA	2BA	2BA
NUT	4BA	2BA	2BA
WASHER, LOCK	4BA	2BA	2BA



- PANEL PIERCING
- [MAX P THICKNESS 3.175mm (.125)]
- NOTES:
- METRIC DIMENSIONS ARE DERIVED FROM ORIGINAL INCH DIMENSIONS.
 - MAXIMUM PANEL THICKNESS 3.175mm (0.125 inch)

FIGURE 8

ACCESSORY SETS WITH STRAIGHT OUTLET CABLES TO DEF STAN 61-12 (PART 5) TYPES A & P

FIGURE 11

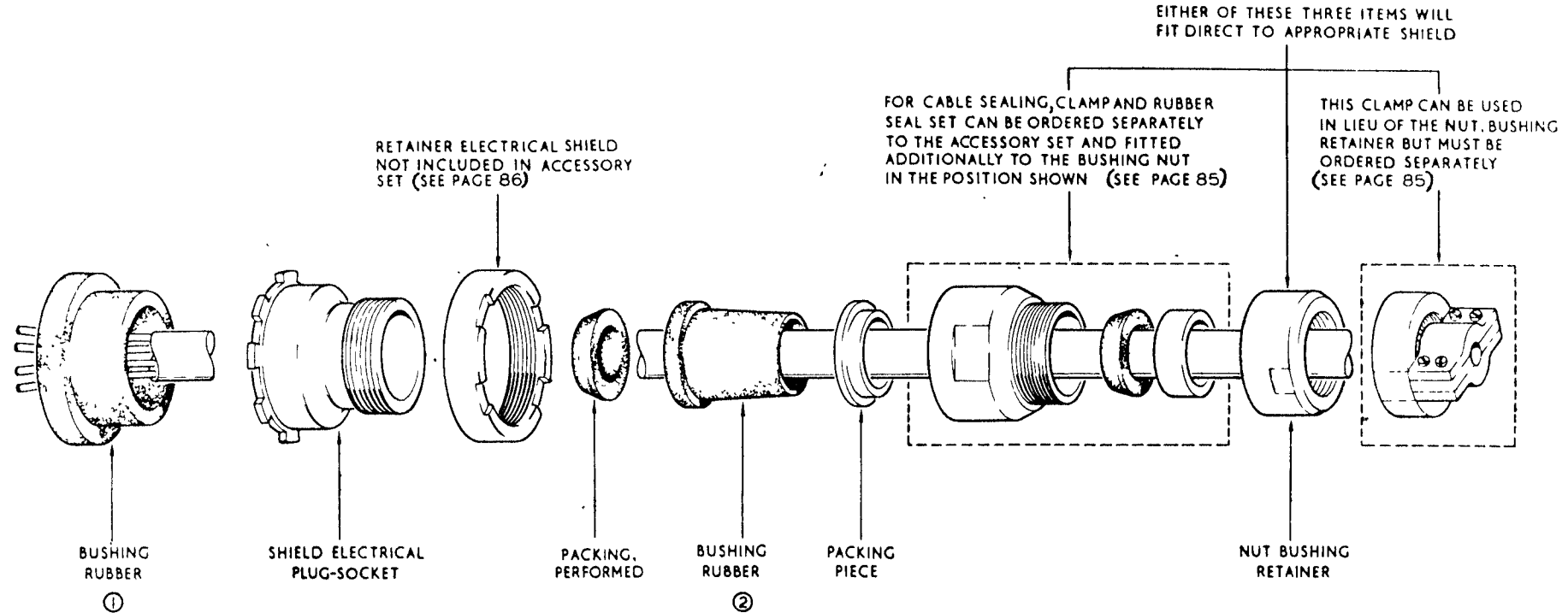

SHELL SIZE	NO OF CONTACTS	CABLE IDENTIFICATION DEF STAN 61-12 (PART 5)		BUSHING RUBBER ①	SHIELD ELECTRICAL	BUSHING RUBBER ②	PACKING PIECE	NUT BUSHING RETAINER	PACKING PERFORMED	ACCESSORY FOR ELECTRICAL PLUG-SOCKET	
		CODE NO	DIMENSIONS		TEMPERATURE CATEGORY T4 ONLY -55°C TO +100°C	STRAIGHT	TEMPERATURE CATEGORY T4 ONLY -55°C TO +100°C		FOR USE WITH SHIELD, ELECTRICAL OR CABLE SEALING CLAMP		TEMPERATURE CATEGORY T4
			MIN	MAX	DRAWING NO CC/B 1175	DRAWING NO CC/B 1176	DRAWING NO CC/B 1181	DRAWING NO CC/B 1358	DRAWING NO CC/B 1045	DRAWING NO CC/B 1180	DRAWING NO CC/B 1295
1	2	37-3-2P	8.54	9.34	011-9877	014-2959	097-0107	014-9228	014-2967	097-0087	014-9270
	3	16-2-3A	5.4	6.2							
	4	16-2-4A	5.9	6.7							
	6	16-2-5A	6.9	7.7							
	4	37-3-4P	9.8	10.5							
2	4	16-2-12A	9.1	9.9	097-0059	014-2961	097-0109	014-9231	014-2972	097-0089	014-9275
	12	16-2-12A	9.1	9.9	097-0059	014-2960	097-0111	014-9230	014-2969	097-0091	014-9275
	15	16-2-15A	10.5	11.5	097-0060	014-2963	097-0240	014-9232	014-2970	097-0239	014-9280
					014-2961	097-0110	014-9232	014-2970	097-0090	014-9282	

ACCESSORY SETS WITH ANGLED OUTLET CABLES TO DEF STAN 61-12 (PART 5) TYPES A & P

FIGURE 12

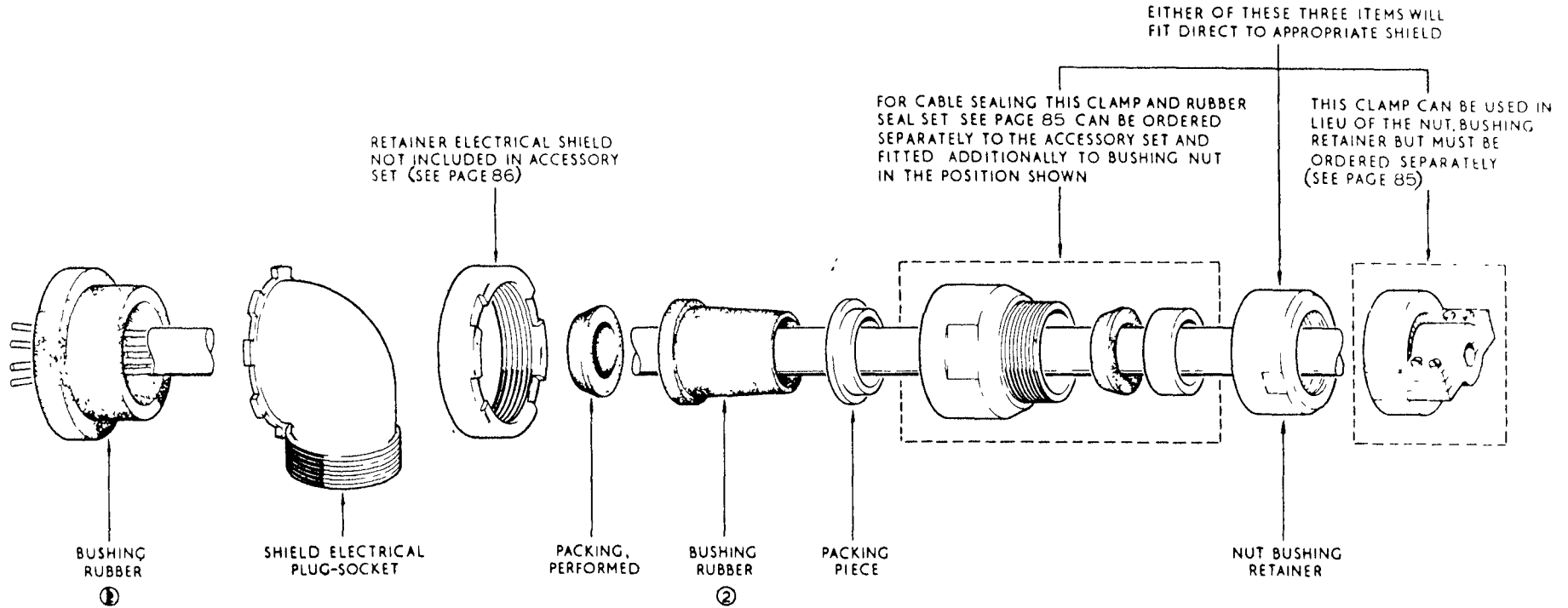

SHELL SIZE	NO OF CONTACTS	CABLE IDENTIFICATION DEF STAN 61-12 (PART 5)		BUSHING RUBBER ①		SHIELD ELECTRICAL	BUSHING RUBBER ②		PACKING PIECE	NUT BUSHING RETAINER FOR USE WITH SHIELD, ELECTRICAL OR CABLE SEALING CLAMP	PACKING PREFORM	ACCESSORY SET ELECTRICAL PLUG & NUT					
		CODE NO	DIMENSIONS mm		TEMPERATURE CATEGORY T4 ONLY -55°C TO +100°C	DRAWING NO CC/B 1175	VARO STOCK NO 5235-99-	TEMPERATURE CATEGORY T4 ONLY -55°C TO +100°C					DRAWING NO CC/B 1133	VARO STOCK NO 5235-99-			
			MIN	MAX											DRAWING NO CC/B 1177	VARO STOCK NO 5235-99-	DRAWING NO CC/B 1358
1	2	37-3-2P	5,5X	9,3X	011-9377	014-2974	097-0107	014-9229	014-2967	097-0087	014-0271						
	3	16-2-3A	5,0	5,9								014-2973	097-0108	014-9229	014-2968	097-0088	014-0273
	4	16-2-4A	5,2	6,2													
	6	16-2-6A	6,9	7,7													
	8	37-3-2P	9,5	10,3													
12	16-2-12A	9,1	9,9	014-2975	097-0111	014-9230	014-2969	097-0081	014-0270								
15	16-2-15A	10,5	11,5							014-2973	097-0210	014-9232	014-2970	097-0239	014-0271		
25	16-2-25A	12,6	13,6	097-0060	014-2973	097-0110	014-9232	014-2970	097-0090							014-0271	

ACCESSORY SETS WITH STRAIGHT OUTLET
 CABLES TO DEF STAN 61 12 (PART 4) TYPES A&C, AND (PART 5) TYPES A&C

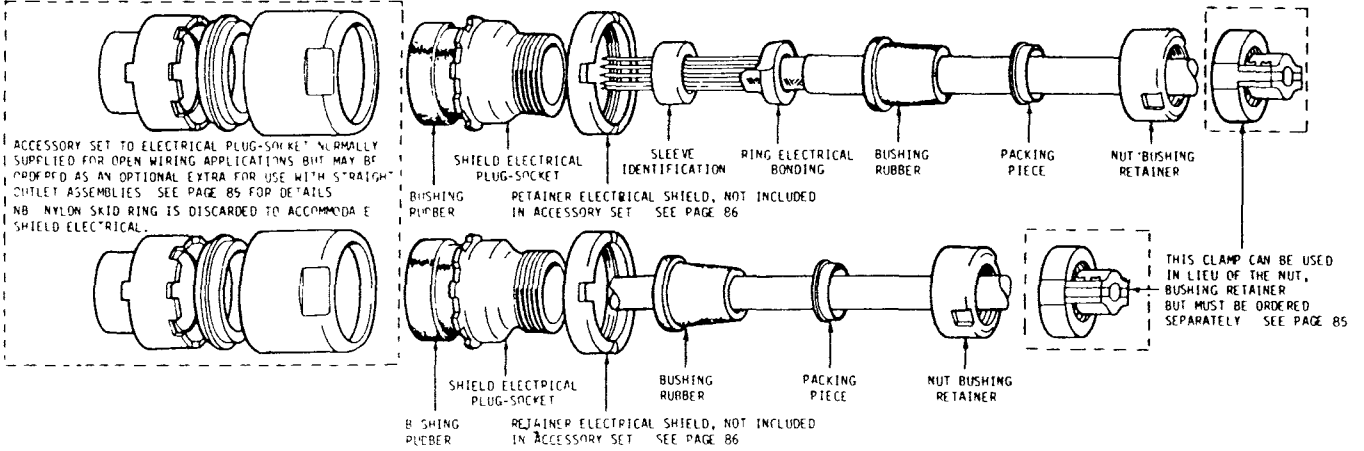

SHELL SIZE	No. OF CONTACTS	CABLE IDENTIFICATION	BUSHING RUBBER	SHIELD ELECTRICAL PLUG-SOCKET	SLEEVE IDENTIFICATION	RING ELECTRICAL BONDING	BUSHING RUBBER	PACKING PIECE	NUT BUSHING RETAINER	ACCESSORY SET ELECTRICAL PLUG-SOCKET
			TEMPERATURE CATEGORY T4 -55°C TO +100°C	STRAIGHT	TEMPERATURE CATEGORY T4 -55°C TO +100°C		TEMPERATURE CATEGORY T4 -55°C TO +100°C		FOR USE WITH SHIELD ELECTRICAL OR CABLE SEALING CLAMP	TEMPERATURE CATEGORY T4 -55°C TO +100°C
		CODE No	DRAWING No CC/B 1175	DRAWING No CC/B 1176	DRAWING No CC/B 1184	DRAWING No CC/B 1182	DRAWING No CC/B 1183	DRAWING No CC/B 1388	DRAWING No CC/B 1045	DRAWING No CC/B 1298
		MIN MAX	NATO STOCK No 3764-99	NATO STOCK No 3935-99	NATO STOCK No 3240-99	NATO STOCK No 3975-99	NATO STOCK No 3246-99	NATO STOCK No 3933-99	NATO STOCK No 3933-99	NATO STOCK No 3933-99

DEF STAN 61-12 (PART 5)

1	12	16 2 12A	9 1	9 9								
	12	16 2 12C	10 0	11 0								
	26	16 2 25A	12 6	13 6								
2	26	16 2 25C	13 6	14 6	097-0059	014-2962	097-0116	014-2941	097-0110	014-9235	014-2970	014-9289
	37	16 2 36C	15 5	16 7								
3	62	16 2 60C	19 1	20 3								

DEF STAN 61 12 (PART 4)

1	12	7 2-12A	5 8	6 4								
	12	7 2-12C	6 6	7 2	011-9877	014-2958	097-0114	014-2939	097-0108	014-9229	014-2968	014-9287
	26	7 2-25A	8 4	9 0								
2	26	7 2 25C	9 2	9 8	097-0059	014-2960	097-0115	014-2942	097-0111	014-9230	014-2969	014-9291
	37	7 2 36A	9 5	10 1								
3	37	7 2 36C	10 4	11 2								
	62	7 2 60A	12 0	12 8								
	62	7 2 60C	13 0	13 8	097 0060	014-2963	097-0116	014-2941	097-0110	014-9235	014-2970	014-9297

NOTE: - COMPLETE ACCESSORY SETS SUITABLE FOR THESE CABLE SIZES ARE NOT YET CODIFIED

ADDITIONAL ACCESSORIES

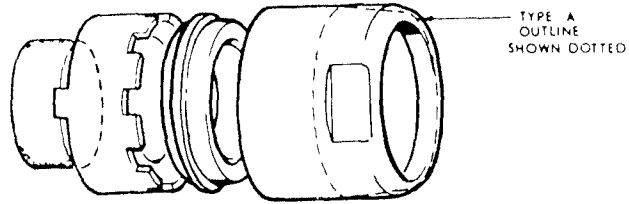

ACCESSORY SET, ELECTRICAL PLUG-SOCKET
(HIGH DENSITY)

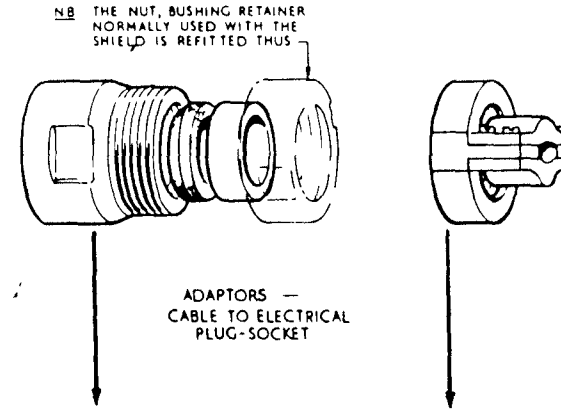

DRAWING NUMBER	NATO STOCK No	SHELL SIZE	CONTACT ARRANGEMENT			
			No. OFF	PLUG OR SOCKET		
CC/C/1386/1	5935-99-014-9310	1	12	P	TYPE A FOR USE WITH ALUMINIUM FREE MALE SHELL AND ALL BRASS CONNECTOR STYLES	
2	9311			S		
3	9312	2	26	P		
4	9313			S		
5	9314	3	37	P		
6	9315			S		
7	9316			P		
8	9317			S		
9	9318	1	12	P		TYPE B FOR USE WITH ALL FEMALE ALUMINIUM CONNECTOR STYLES
10	9319			S		
11	9320	2	26	P		
12	9321			S		
13	9322	3	37	P		
14	9323			S		
15	9324			P		
16	9325			S		

DRAWING NUMBER	NATO STOCK No	TYPE II		MAY BE USED WITH SHIELD ELECTRICAL PLUG SOCKET LISTED BELOW	
		DRAWING NUMBER	NATO STOCK No	STRAIGHT	ANGLED
				NATO STOCK No	NATO STOCK No
CC/B/1237/1	NOT PROVISIONED	CC/B/1238/1	5935-99-014-2982	5935-99-014-2953 or 5935-99-014-2960	5935-99-014-2973 or 5935-99-014-2981
CC/B/1237/2		CC/B/1238/2	5935-99-014-2983	5935-99-014-2959	5935-99-014-2974
CC/B/1237/3		CC/B/1238/3	5935-99-014-2984	5935-99-014-2960	5935-99-014-2975
CC/B/1237/4	5935-99-014-9225	CC/B/1238/4	5935-99-014-2985	5935-99-014-2961	5935-99-014-2976
CC/B/1237/5	NOT PROVISIONED	CC/B/1238/5	5935-99-014-2986	5935-99-014-2962 or 5935-99-014-2963	5935-99-014-2977 or 5935-99-014-2978
CC/B/1237/6	5935-99-014-9227	CC/B/1238/6	5935-99-014-2987	5935-99-014-2964 or 5935-99-014-2965	5935-99-014-2979 or 5935-99-014-2980

PLUGS AND SOCKETS, ELECTRICAL PATTERN 104
 SPARES

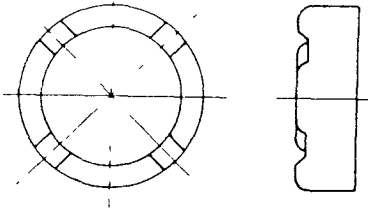

RETAINER, ELECTRICAL SHIELD

SHELL SIZE	THREAD	DRAWING NUMBER	NATO STOCK NUMBER
1	0.7969 x 26 TPI	CC/B 1218/1	5935-99-013-9160
	0.8437 x 20 TPI	CC/B 1218/4	5935-99-013-9163
2	1.0156 x 26 TPI	CC/B 1218/2	5935-99-013-9161
	1.0625 x 20 TPI	CC/B 1218/5	5935-99-013-9164
3	1.4062 x 26 TPI	CC/B 1218/3	5935-99-013-9162
	1.4375 x 20 TPI	CC/B 1218/6	5935-99-013-9165

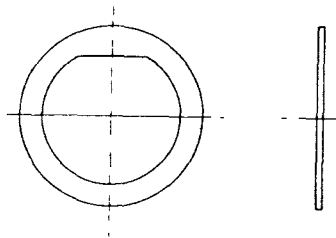

WASHER LOCK

SHELL SIZE	DRAWING NUMBER	NATO STOCK NUMBER	FRONT MOUNT	BACK MOUNT
1	CC/B 1220/1	5310-99-013-9166	-	✓
	CC/B 1220/2	5310-99-013-9167	✓	-
2	CC/B 1220/2	5310-99-013-9167	-	✓
	CC/B 1220/3	5310-99-013-9168	✓	-
3	CC/B 1220/3	5310-99-013-9168	-	✓
	CC/B 1220/4	5310-99-014-9177	✓	-

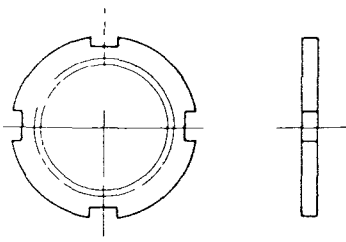

NUT, PLAIN ROUND

SHELL SIZE	DRAWING NUMBER	NATO STOCK NUMBER	FRONT MOUNT	BACK MOUNT
1	CC/B 1219/1	5310-99-013-9169	-	✓
	CC/B 1219/2	5310-99-013-9170	✓	-
2	CC/B 1219/2	5310-99-013-9170	-	✓
	CC/B 1219/3	5310-99-013-9171	✓	-
3	CC/B 1219/3	5310-99-013-9171	-	✓
	CC/B 1219/4	5310-99-014-9176	✓	-

NOTES:

- There are two methods of mounting the type C Style X (female shell), these alternatives give flexibility when positioning dimension A (see: diagram page 76).
 - Front mounting. This is the usual method and for which accessories will be supplied as part of the Standard item.
 - Rear mounting. To utilize this method of mounting the appropriate parts above will have to be ordered separately.
- The tables above show, by means of a tick, the normal front end and alternative back and mounting components available for backing the shell. Outline dimensions of these parts are shown as C and C' in diagrams on page 76.
- indicates that the column heading is not applicable.

THESE ITEMS ARE NORMALLY SUPPLIED AS PARTS OF THE APPROPRIATE ASSEMBLIES THEY NEED ONLY BE ORDERED SEPARATELY TO REPLACE LOST OR DAMAGED PARTS

FIGURE 17

PLUGS AND SOCKETS, ELECTRICAL. PATTERN 104

COVERS ELECTRICAL PLUG/SOCKET
(POLYTHENE OR BRASS)

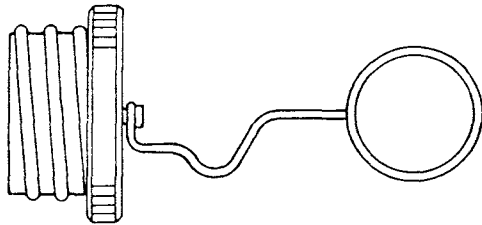

FOR MALE SHELLS

POLYTHENE			
SHELL SIZE	THREAD	DRAWING NUMBER	NATO STOCK NUMBER
1	6 TPI	CC/B 1201/1	5935-99-013-9181
2	6 TPI	CC/B 1201/2	5935-99-013-9182
3	6 TPI	CC/B 1201/3	5935-99-013-9183
	8 TPI	CC/B 1201/4	5935-99-014-9298

BRASS			
SHELL SIZE	THREAD	DRAWING NUMBER	NATO STOCK NUMBER
1	6 TPI	CC/B 1204/1	5935-99-013-9184
2	6 TPI	CC/B 1204/2	5935-99-013-9185
3	6 TPI	CC/B 1204/3	5935-99-013-9186
	6 TPI	CC/B 1204/4	5935-99-014-9301

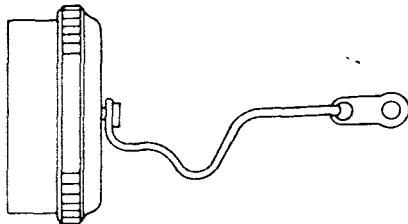

FOR FEMALE SHELLS

POLYTHENE			
SHELL SIZE	THREAD	DRAWING NUMBER	NATO STOCK NUMBER
1	6 TPI	CC/B 1202/1	5935-99-013-9187
2	6 TPI	CC/B 1202/2	5935-99-013-9188
3	6 TPI	CC/B 1202/3	5935-99-013-9189
	8 TPI	CC/B 1202/4	5935-99-014-9299

BRASS			
SHELL SIZE	THREAD	DRAWING NUMBER	NATO STOCK NUMBER
1	6 TPI	CC/B 1205/1	5935-99-013-9190
2	6 TPI	CC/B 1205/2	5935-99-013-9191
3	6 TPI	CC/B 1205/3	5935-99-013-9192
	6 TPI	CC/B 1205/4	5935-99-014-9302

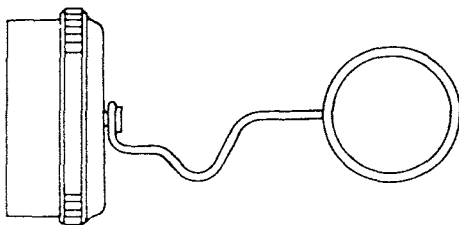

FOR COUPLING ASSEMBLIES

POLYTHENE			
SHELL SIZE	THREAD	DRAWING NUMBER	NATO STOCK NUMBER
1	6 TPI	CC/B 1203/1	5935-99-013-9193
2	6 TPI	CC/B 1203/2	5935-99-013-9194
3	6 TPI	CC/B 1203/3	5935-99-013-9195
	8 TPI	CC/B 1203/4	5935-99-014-9300

BRASS			
SHELL SIZE	THREAD	DRAWING NUMBER	NATO STOCK NUMBER
1	6 TPI	CC/B 1206/1	5935-99-013-9196
2	6 TPI	CC/B 1206/2	5935-99-013-9197
3	6 TPI	CC/B 1206/3	5935-99-013-9198
	8 TPI	CC/B 1206/4	5935-99-014-9303

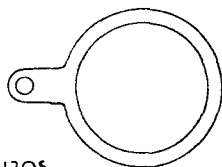

FOR ALUMINIUM COARSE THREAD
IN CONJUNCTION WITH CC/B 1202 & CC/B 1205

SIZE	DRAWING NUMBER	NATO STOCK NUMBER
1	CC/B 1392/1	5935-99-014-9528
2	CC/B 1392/2	5935-99-014-9529
3	CC/B 1392/3	5935-99-014-9530

RING, CONNECTING

FIGURE 19

PLUGS AND SOCKETS, ELECTRICAL PATTERN 104
SPANNER KIT

The special tools required for the correct assembly of pattern 104 plugs and sockets are available as a kit of parts under the NATO Stock number: 5180-99-014-9309.

DESCRIPTION	SHELL SIZE	NATO STOCK NUMBER	CONTROL DRAWING NO	
 BAR TOMMY	NOT APPLICABLE	5120-99-097-0143	CC/B 1269	
 SPANNER WRENCH	1	5120-99-097-0133	CC/B 1190/1	
	2	5120-99-097-0137	CC/B 1190/2	
	3	5120-99-097-0140	CC/B 1190/3	
 HOLDING TOOL, ELECTRICAL PLUG-SOCKET	1	5120-99-056-9019	CC/C 1192/1	
	2	5120-99-056-9020	CC/C 1192/2	
	3	5120-99-056-9021	CC/C 1192/3	
 SPANNER, WRENCH	1	5120-99-013-9199	CC/B 1231/1	
	2	5120-99-013-9200	CC/B 1231/2	
	3	6 TPI	5120-99-013-9201	CC/B/1231/3
		8 TPI	5120-99-014-9308	CC/B 1231/4

FIGURE 20

DEF STAN 59-35 (PART 1) SECTION 2/1
PLUGS AND SOCKETS ELECTRICAL, PATTERN 104, SEALED,
WITH SOLDERED TERMINATIONS AND THREADED COUPLING,
FOR DC AND LF APPLICATIONS

Amendment 2

1. Page 3, Clause 1, Scope

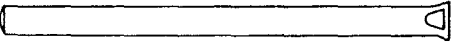
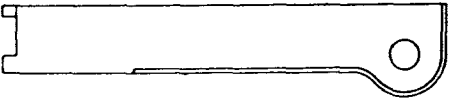
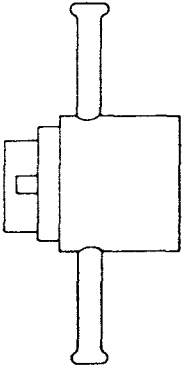
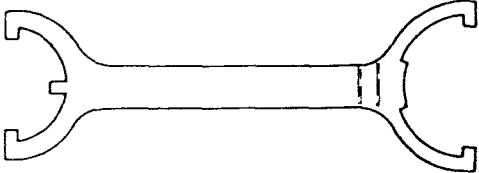
Add new subclause e. For connector-cable assembly, reference should be made to Def Stan 59-95 (Part 1) and Def Stan 59-95 (Part 1) Section 1.

2. Make a note of this amendment on the Amendment Record.

D/D Stan/318/26/17

23 July 1992
Ministry of Defence
Directorate of Standardization
Kentigern House
65 Brown Street
GLASGOW G2 8EX

OBSOLESCE

Ministry of Defence

Defence Standard

59 - 35 (Part 1)

Section 2 / Issue 1

24th August 1971

**PLUGS AND SOCKETS,
ELECTRICAL**

**PATTERN 104, SEALED,
WITH SOLDERED TERMINATIONS
AND THREADED COUPLING,
FOR D.C. AND LOW FREQUENCY
APPLICATIONS**

OBSOLESCE

THIS DEFENCE STANDARD WILL NOT BE UPDATED AND IS
NOT TO BE USED FOR THE PURCHASE OF NEW EQUIPMENT

AMENDMENT RECORD

AMENDMENT NUMBER	DATE	SIGNATURE

PLUGS AND SOCKETS, ELECTRICAL, PATTERN 104
SEALED, WITH SOLDERED TERMINATIONS AND
THREADED COUPLING, FOR D.C. AND LOW
FREQUENCY APPLICATIONS

This Section of DEF STAN 59 - 35 (PART 1)
supersedes DEF-5325-2, dated April 1965 and
Table I of DEF STAN 59 - 4 (PART 4)

1. This Section of DEF STAN 59 - 35 (PART 1) specifies the requirements for plugs and sockets, electrical, Pattern 104, sealed, with soldered terminations and threaded coupling, for d.c. and low frequency applications, for use by all Departments of the Ministry of Defence.
2. This Section, is to be used in conjunction with DEF STAN 59 - 35 (PART 1) 'Plugs and sockets, electrical, with soldered terminations (d.c. and low frequency applications)', which is the generic specification.
3. Tables I(A) to I(M) give the details of the standard ranges of plugs and sockets, electrical, Pattern 104, to be used in all future designs of equipment and where practicable, for the maintenance of existing equipment.
4. This Section, together with DEF STAN 59 - 35 (PART 1) contains all necessary technical information and it is the definitive specification for these items. It shall be invoked for all tender and contract purposes.
5. All Departments of the Ministry of Defence are to implement this Section of DEF STAN 59 - 35 (PART 1) from the date of issue.
6. This Section of DEF STAN 59 - 35 (PART 1) has been agreed by all authorities concerned. If it should be found unsuitable for a particular requirement, the Director of Standardization should be informed of the circumstances. Any enquiries regarding this Section in relation to an invitation to tender or a contract in which it is invoked should be addressed to the Qualification Assurance Authority named in that invitation to tender or contract.

INDEX TO CONTENTS

<u>CLAUSE</u>	<u>TITLE</u>	<u>PAGE</u>
1.	SCOPE	3
2.	RELATED SPECIFICATIONS AND DOCUMENTS	3
3.	INFORMATION TO BE SUPPLIED BY THE PURCHASER	3
4.	PURPOSE OF ILLUSTRATIONS AND DRAWINGS	3
5.	STYLE REFERENCE	4
6.	QUALIFICATION APPROVAL, PROCEDURE FOR	4
7.	BATCH ACCEPTANCE TEST PROCEDURE	8
8.	SYSTEMATIC QUALITY ASSURANCE TESTS	10
9.	TEST REQUIREMENTS	11-21
10.	TECHNICAL NOTES	22
11.	CLASSIFICATION	22
12.	RATINGS	22
13.	INDEX TO STANDARD PLUGS AND SOCKETS, ELECTRICAL	23

DRAWINGS AND ILLUSTRATIONS

	PERMISSIBLE ORIENTATIONS	26-29
FIGURE 1-3	CONTACT SIZING AND HOLDING FORCE GAUGES AND TEST PRODS	24
FIGURE 4	FIXTURE FOR CONTACT STRENGTH TEST	25
FIGURE 5	OVERALL ASSEMBLED LENGTHS	74
FIGURE 6-8	METHODS OF MOUNTING, DIMENSIONS, AND PANEL PIERCING DETAILS	75-77
FIGURE 9-17	ACCESSORIES	78-86
FIGURE 18-19	COVERS, ELECTRICAL, PLUG/SOCKET	87-88
FIGURE 20	SPANNER KIT	89
ANNEX A	ACCESSORIES FOR WIRES, CORDS AND CABLES, ELECTRICAL TYPE B CONSTRUCTION (OUTER METAL SCREEN)	90

SPECIFICATION FOR PLUGS AND SOCKETS, ELECTRICAL
PATTERN 104, SEALED, WITH SOLDERED TERMINATIONS
AND THREADED COUPLING, FOR D.C. AND LOW
FREQUENCY APPLICATIONS

1. SCOPE

a. This specification relates to a range of multi-contact sealed circular plugs and sockets with threaded couplings, silver plated contacts and soldered terminations for d.c. and low frequency applications. Pattern 104 plugs and sockets are available in three basic types:

Type 1 A4 - Aluminium shells with fine thread having inserts suitable for severity T4 (-55/+100°C)

Type 2 B4 - Brass shells with coarse thread having inserts suitable for severity T4 (-55/+100°C)

Type 3 C4 - Aluminium shells with coarse thread, round flange, having inserts suitable for severity T4 (-55/+100°C).

b. Items listed in this Standard include those that are interchangeable and mateable with the circular multi-contact plugs and sockets shown in the superseded DEF-5321 (designated the Mark IV type). Pattern 104 plugs and sockets have a wider temperature range and improved insulation properties. Female contacts are of the restricted entry type.

c. This Standard is to be used in conjunction with DEF STAN 59-35 (PART 1) all the requirements of which are applicable unless otherwise stated herein. Details of dimensions, ratings, and test values applicable to the standard range are defined herein.

2. RELATED SPECIFICATIONS AND DOCUMENTS

These are listed in DEF STAN 59-35 (PART 1).

3. INFORMATION TO BE SUPPLIED BY PURCHASER

a. When ordering components to this Section of the Standard it is essential to quote the relevant NATO Stock Number (where allotted), style reference, and to quote this Section of the Standard.

b. Before using the NATO Stock Numbers given in this Section of the Standard, reference should be made to the Joint Service qualified products list of electronic parts (RCG 4) to ascertain that a Qualification Approval Certificate is extant for the item concerned.

4. ILLUSTRATIONS AND DRAWINGS

a. The essential purpose of the illustrations and drawings which form part of this Section of the Standard is to ensure mechanical interchangeability. It is essential that equipment designers work to the limits stated and not to the dimensions of individual specimens. Where official drawings are quoted they are mandatory. Copies of such drawings are obtainable from:

EQD, Section T2(d)
 'Aquila' Golf Road
 Bromley, Kent. BR1 2JB

b. HM Government drawings referred to are now associated with this Section of the Defence Standard and therefore they must not be altered in any way which will affect function, material, or interchangeability unless the Defence Standard itself is amended. Holders of master drawings must endorse them accordingly.

5. STYLE REFERENCES

The style references used in this Section of the Standard are abbreviations to identify individual plug and socket variants. A typical reference is:

FUNCTION	PATTERN	TYPE	TEMPERATURE	--- SHELL ---		NO OF CONTACTS	ORIENTATION
			SEVERITY	STYLE	SIZE		
P	04	A	4	X	2	6	0

Where the function is denoted by P - plug, S - socket, Pattern 104 by 04. Type of shell (material) by A - aluminium fine thread, B - brass coarse thread and C - aluminium coarse thread. Temperature severity by 4 - (-55/+100°C). Shell style by X - fixed female shell, F - free male shell, or C - free female shell (coupler). The shell size by 1, 2, or 3 as applicable. Number of contacts by 2, 4, etc. Orientation by 0-5, as applicable.

6. QUALIFICATION APPROVAL

a. Provision of samples.

The manufacturer shall submit specimens in accordance with Schedule 1 for which approval is desired, or a minimum quantity of specimens, if approval for only one shell size is desired, in accordance with Schedule 1.

b. Grouping of specimens.

The specimens shall be grouped as indicated in Schedule 1.

c. Test incidence.

Initial measurements referred to in Table 4 of DEF-5011 and in this Section of the Standard as Group 0, shall be carried out immediately prior to the commencement of tests on subsequent groups and the results shall be recorded. Each test shall be applied in the order listed in Schedule 7 and where measurements are required the results shall be recorded. Where tests are not applicable this is indicated in Schedule 7.

**SCHEDULE 1
PATTERN 104**

QUALIFICATION APPROVAL ITEMS

COLUMNS		1				2		3		4	
		(a)		(b)							
SHELL SIZE/NO CONTACTS (TOTAL N OF MATING PAIRS)		1 - 6 x 5A (21) +2 - 6 x 5A } (21) 2 - 12 x 5A }		+3 - 18 x 5A } (32) 3 - 25 x 5A }		1 - 2 x 19A (6) 2 - 4 x 19A (6) +3 - 6 x 19A } (6) 3 - 9 x 19A }		2 - 2 x 5A (6) +3 - 3 x 60A, 1 x 19A } (6) 3 - 2 x 60A, 3 x 19A }		1 - 12 x 3A (9) 2 - 26 x 3A (9) 3 - 62 x 3A (9)	
GROUP	TEST NO.	ALL		ALL		ALL		ALL		ALL	
15.5		ALL SPECIMENS WITH FEMALE CONTACTS									
		TOTAL MATED PAIRS	TEST DISTRIBUTION	TOTAL MATED PAIRS	TEST DISTRIBUTION	TOTAL MATED PAIRS	TEST DISTRIBUTION	TOTAL MATED PAIRS	TEST DISTRIBUTION	TOTAL MATED PAIRS	TEST DISTRIBUTION
1	15.12 to 15.18 incl	8	ALL	4	ALL	6	ALL	4	ALL	6	ALL
	15.19 15.20		-		1 Only NOT APPLICABLE		-		-		
2	15.21	+8	ALL	+4	ALL	+3	ALL	2	ALL	6	ALL
3	15.22 and 15.23 15.24	8	ALL	4	ALL	6	ALL	4	ALL	6	ALL
4	15.25				NOT APPLICABLE						
5	15.26	2	ALL	1	ALL	-	-	-	-	-	-
6	15.27 and 15.28	4	ALL	2	ALL	-	-	-	-	3	ALL
7	15.29 to 15.33	8	ALL	4	ALL	3	ALL	2	ALL	6	ALL
8	15.34	4	ALL	13	4	-	-	-	-	-	-
	15.35		-		13						

Items applicable to this Schedule are on page 6.

REF ID: A66577

NOTES APPLICABLE TO SCHEDULE 1

1. Where approval is sought for the complete range a total of 131 mated pairs shall be submitted.
 2. Where approval is sought for socket couplers, these shall be included as mated items in Groups 2, 3, and 7. This must include 3 of each shell size in A4 and B4.
 3. Specimens marked thus + have high voltage rated contacts and must be included in Group 2.
 4. Specimens marked / have heavy current rated contacts and must be included in Group 3.
 5. a. For approval, specimens shall be submitted of each shell size, half the specimens in each shell size shall carry the maximum number of contacts. The quantities shall be in accordance with column 1(b) for shell size 3 and column 1(a) for each of the shell sizes 1 and 2. Where approval is sought for less than the 3 shell sizes given in column 1, the quantity submitted shall be in accordance with column 1(b).
Note: Test 15.35 (Solvent resistance) is performed on the maximum shell size only for which approval is sought.
 - b. Where approval is sought for more than one of the shell size/contact arrangements given in column 2, the quantity of specimens submitted shall be in accordance with column 2 for the largest shell size for which approval is sought together with an equal quantity of any other shell size.
 - c. Where approval is required for a range which includes the shell size/contact arrangements listed in columns 3 and 4 additional specimens shall be supplied in accordance with columns 3 and 4.
 - d. The specimens supplied shall consist of equal numbers of each female shell style with socket contacts and each female shell style with pin contacts together with the appropriate number of mating shell styles for which approval is sought.
 - e. Results of tests on plugs and sockets fitted with accessories listed herein may be accepted as evidence for approval of the accessories in conjunction with the requirement listed in Note 9 below.
 - f. Any departure from the requirements of Schedule 1 shall be agreed with the Approval Authority.
6. Three specimens of each shell size, style, contact arrangement, and orientation for which approval is sought shall be applied for test to clauses 15.2 and 15.3.
RE: Tests to clauses, 15.2 and 15.3 are non-destructive. Tested specimens that have passed these tests may therefore be returned to the manufacturer's stock.
 7. Three sets of piece parts covering the standard range items for which approval is sought shall be supplied for test to clause 15.1 (iii). Where common piece parts are involved no more than three specimens of each part need be submitted.

NOTES (CONTD)

8. Twenty male contacts are to be supplied as applicable for test 15.16 Contact strength.
9. In addition to the test evidence obtained from 5(e) above three of each accessory item shall be subjected to test clause 15.1.

7. BATCH ACCEPTANCE TEST PROCEDURE

Components submitted for acceptance shall be tested in accordance with DEF-5001-C, Section 3, and shall be subjected to the following tests:

- a. 100 per cent acceptance tests. (See DEF-5001-C, Section 3).

SCHEDULE 2

TEST NO. DEF STAN 59-35 (PART 1)	TITLE OF TEST
15.1(i)	Visual examination
15.6	Sealing (excluding panel sealing) <u>Note:</u> The component to be tested in one direction only, using a pressure differential of 1 bar (1 atmosphere)
15.11	Voltage proof. (As for acceptance sampling) (Method A)

- b. Sampling test. (See DEF-5001-C, Section 3)

- (1) Tests bracketed together within a group are considered as a sequence and must be performed as such, using the same sample throughout.
- (2) Information on the re-submission of rejected batches is given in DEF-131-A.

- c. Group 'A' tests.

SCHEDULE 3

TEST NO. DEF STAN 59-35 (PART 1)	TITLE OF TEST	AQL	INSPECTION LEVEL	TEST CATEGORY
15.2	Compatibility (gauging) or Compatibility assurance test (See note below)	1%	II	Non-destructive
15.4	Engagement and disengagement	1%	II	Non-destructive
15.5	Contact holding force (without sizing)	1%	II	Non-destructive

- Notes:
1. Where compatibility gauges (Test 15.2) are not available a Compatibility Assurance Test shall be applied. For the Compatibility Assurance Test the manufacturer shall demonstrate to the Qualification Assurance Authority that his system of piece part checking and assembly methods together with final mechanical measurements will ensure that the finished components will meet the compatibility requirements.
 2. The Inspection Levels and AQL shall be agreed by the Qualification Assurance Authority in relation to each particular manufacturer's system.

d. Group 'B' tests.

SCHEDULE 4

TEST NO. DEF STAN 59-35 (PART 1)	TITLE OF TEST	AQL	INSPECTION LEVEL	TEST CATEGORY
15.12	Solderability (DEF-5011, Section 5, Test 14 (c) (ii), or 14 (e) (ii) solderability only	4%	S3	Destructive
15.12	Soldering resistance to heat DEF-5011, Section 5, Test 14 (c) (iii), or 14 (e) (ii)			
15.5	Contact holding force			
15.7 ∅	Contact resistance	4%	S3	Destructive
15.8 ∅	Shell continuity			
	∅Note: These tests may be carried out using a test voltage not exceeding 2.5 V and a test current not exceeding 1 amp			
15.9	Insulation resistance	4%	S3	Destructive
15.30	Contact retention (in insert)			
15.31	Insert retention (in shell)	4%	S3	Destructive
15.31(i)	Sealing (excluding panel sealing) The component to be tested in one direction only using pressure differential of 1 bar (1 atmosphere)			

e. Disposal of samples. (See DEF-5001-C, Section 3.)

8. SYSTEMATIC QUALITY ASSURANCE TESTS

Tests bracketed together within a Group are considered as a sequence and must be performed as such using the same sample throughout.

a. Group 'C' tests.SCHEDULE 5

TEST NO DEF STAN 59-35 (PART 1)	TITLE OF TEST	AQL	INSPECTION LEVEL	TEST CATEGORY
15.1(ii)	Dimensions (outline). Additionally, issue number of manufacturer's drawing schedule to be checked against that quoted on approval certificate. Any significant differences to be reported to the Approving Authority	1%	S3	Non-destructive
15.7 15.8 15.17	Contact resistance Shell continuity Temperature, rapid change 15.17(i), (ii), and (iii) not required	4%	S3	Destructive
15.21	Damp heat (long term) (21 days)			
15.21(i)	Working voltage application			
15.21.2(i)	Contact resistance			
15.21.2(ii)	Shell continuity			
15.21.2(iii)	Insulation resistance			
15.21.2(iv)	Visual examination			
15.21.2(v)	Disengagement and engagement			
15.21.2(vi)	Sealing			
15.21.2(viii)	Voltage proof			
15.4 15.7 15.8	Engagement and disengagement force Contact resistance Shell continuity	4%	S3	Destructive
15.22	Endurance, mechanical (50 operations)			
15.22(i) 15.22(ii) 15.22(iii)	Visual examination Engagement and disengagement force Contact holding force (without sizing)			
15.23.1 15.23.1(i) 15.23.1(ii) 15.23.1(iii) 15.23.1(iv) 15.23.1(v) 15.23.1(vi)	Endurance, high temperature (500 hours only) Sealing (hot) Insulation resistance (hot) Contact resistance Shell continuity Voltage proof Sealing	4%	S3	Destructive

b. Group 'D' tests.

SCHEDULE 6

- (1) The sample size and performance requirements for Group 'D' tests shall be in accordance with Qualification Approval requirements for the tests specified herein (see clause 6).
- (2) Components for Group 'D' shall be selected from batches which have successfully passed the acceptance tests and the batch size from which this selection is made shall be at least three-times the required sample quantity.

c. Disposal of samples. (See DEF-5001-C Section 4.)

9. TEST REQUIREMENTS

a. The general test requirements are fully defined in DEF STAN 59 - 35 (PART 1). The following Table contains additional information on test conditions and requirements for the range of standard items defined herein.

SCHEDULE 7

TEST NO. DEF STAN 59 - 35 (PART 1)	TITLE	DESCRIPTION	REQUIREMENTS
15.1	GENERAL EXAMINATION	As specified	As specified
(i)	Visual examination	As specified	As specified
(ii)	Dimensions (outline)	As specified	As specified
(iii)	Dimensions (detail) and materials	As specified	As specified
(iv)	Weight	As specified	As specified (see Tables IA-IV)
15.2	COMPATABILITY ASSURANCE	As specified	As specified
15.3	POLARIZATION	As specified	As specified
(i)	Polarizing device	As specified	As specified
(ii)	Mis-mating	As specified. Applied force 110 newtons(25 lbf approx)	As specified
(iii)	Orientation	As specified. (Measurement of force not-applicable)	As specified

DEF STAN 59 - 35 (PART 1)
SECTION 2/1

TEST NO DEF STAN 59 - 35 (PART 1)	TITLE	DESCRIPTION	REQUIREMENTS								
15.4	ENGAGEMENT AND DISENGAGEMENT FORCE	As specified. (Measurement of force is not required)	By hand								
15.5	CONTACT HOLDING FORCE (resilient contacts only)	As specified using gauge shown on page 24.	As specified								
15.6	SEALING	As specified. At a pressure differential of 1 bar (1 atmosphere)	As specified								
15.7	CONTACT RESISTANCE	As specified	Maximum - 5 milliohms								
15.8	SHELL CONTINUITY	As specified	Maximum - 5 milliohms								
15.9	INSULATION RESISTANCE	As specified. Using Methods A and B	For Method A not less than 5000 Megohms. Results of Method B are to be recorded								
15.10	IONIZATION	NOT APPLICABLE									
15.11	VOLTAGE PROOF	As specified Method B. For proof voltage see Schedule B on page 22.	As specified								
15.12	SOLDERING	Soldering-iron method. <table border="1" style="margin-left: auto; margin-right: auto;"> <thead> <tr> <th>Bit size</th> <th>Contact rating:</th> </tr> </thead> <tbody> <tr> <td>3.175 mm (0.125 in)</td> <td>3A 5A (size 20)</td> </tr> <tr> <td>4.75 mm (0.187 in)</td> <td>19A</td> </tr> <tr> <td>7.62 mm (0.300 in)</td> <td>35A 60A</td> </tr> </tbody> </table>	Bit size	Contact rating:	3.175 mm (0.125 in)	3A 5A (size 20)	4.75 mm (0.187 in)	19A	7.62 mm (0.300 in)	35A 60A	Satisfactory tinning. No loosening of parts or other damage such as would impair performance
Bit size	Contact rating:										
3.175 mm (0.125 in)	3A 5A (size 20)										
4.75 mm (0.187 in)	19A										
7.62 mm (0.300 in)	35A 60A										
15.13	BUMPING	As specified. Under 'Atmospheric Conditions for Measurement'	Maximum intermittency - 10 microseconds								
(i)	Contact resistance	As in 15.7	Maximum - 5 milliohms								
(ii)	Sealing	As in 15.6	As specified								
15.14	VIBRATION	As specified. Under 'Atmospheric Conditions for Measurement'. Severity V2	Maximum intermittency 10 microseconds								
(i)	Contact resistance	As in 15.7	Maximum - 5 milliohms								

TEST NO DEF STAN 59 - 35 (PART 1)	TITLE	DESCRIPTION	REQUIREMENTS
15.14 (contd) (ii)	Sealing	As in 15.6	As specified
15.15 (i) (ii)	SHOCK Contact resistance Sealing	As specified, at Severity S2 As in 15.7 As in 15.6	Maximum intermittency 10 microseconds Maximum - 5 milliohms As specified
15.16 (i) (ii)	ACCELERATION Contact resistance Sealing	As specified, at Severity A1 As in 15.7 As in 15.6	Maximum - 5 milliohms As specified
15.17 (i) (ii) (iii)	TEMPERATURE, RAPID CHANGE Contact resistance Shell continuity Sealing	As specified, Severity T4 As in 15.7 As in 15.8 As in 15.6	As specified Maximum - initial reading plus 5 milliohms Maximum - initial reading plus 5 milliohms As specified
15.18 15.18.1 (i) 15.18.2 (i) 15.18.3 15.18.4	CLIMATIC Intermediate measurements Visual examination Temperature, dry heat Sealing (hot) Damp heat, accelerated Temperature, dry cold	As specified. Humidity Class H6. Temperature Severity T4. As specified As specified As specified As specified As specified	As specified As specified As specified As specified

TEST NO DEF STAN 59 - 35 (PART 1)	TITLE	DESCRIPTION	REQUIREMENTS
15.18.4 (contd)			
(i)	Disengagement and engagement (cold)	As specified	By hand
(ii)	Sealing (cold)	As specified	As specified
15.18.5	Air density low	As specified, Severity D1 or D2 as appropriate	
(i)	Voltage proof	As specified. For proof voltages see Schedule B on page 22	As specified
15.18.6(a)	Damp heat, accelerated, with assisted recovery (Class H3 only)	NOT APPLICABLE	
15.18.6(b)	Damp heat, accelerated with 24 hour recovery (Class H5 only)	NOT APPLICABLE	
15.18.6(c)	Damp heat, accelerated (Class H6 only)	As specified	
(i)	Working voltage application	As specified. For working voltages see Schedule B on page 22	As specified
15.18.6(d)	Damp heat, accelerated with temperature, dry cold (Class H7 only)	NOT APPLICABLE	
15.18.7	Final measurements	As specified	
(i)	Contact resistance	As in 15.7	Maximum - initial reading plus 5 milliohms
(ii)	Shell continuity	As in 15.8	Maximum - initial reading plus 5 milliohms
(iii)	Insulation resistance	As in 15.9 Method A within 30 min after completion of recovery	Minimum - 100 Megohms

TEST NO DEF STAN 59 - 35 (PART 1)	TITLE	DESCRIPTION	REQUIREMENTS
15.18.7 (cont'd)			
(iv)	Visual examination	As specified	As specified
(v)	Disengagement and engagement	As specified	By hand
(vi)	Sealing	As in 15.6	As specified
(vii)	Insulation resistance (Class H5 only)	NOT APPLICABLE	
(viii)	Voltage proof	As specified. For proof voltages see Schedule B page 22	As specified
15.19	FIRE RISK	As specified	As specified
15.20	FIREPROOFNESS	—	NOT APPLICABLE
15.21	DAMP HEAT, (LONG TERM)	As specified. Severity H6	As specified
(i)	Working voltage application (omitted for Class H3)	As specified. For working voltages see Schedule B	As specified
15.21.1(a)	Assisted recovery (Class H3 only)	NOT APPLICABLE	
15.21.1(b)	Recovery (Class H5 only)	NOT APPLICABLE	
15.21.1(c)	Recovery (Classes H6 and H7 only)	As specified	
15.21.2	Final measurements		
(i)	Contact resistance	As in 15.7	Maximum - initial reading plus 5 milliohms
(ii)	Shell continuity	As in 15.8	Maximum - initial reading plus 5 milliohms
(iii)	Insulation resistance	As specified. Method A	Minimum - 50 Megohms
(iv)	Visual examination	As specified	As specified

DEF STAN 59 - 35 (PART 1)
SECTION 2/1

TEST NO DEF STAN 59 - 35 (PART 1)	TITLE	DESCRIPTION	REQUIREMENTS
15.21.2 (contd)			
(v)	Disengagement and engagement	As specified	By hand
(vi)	Sealing	As in 15.6	As specified
(vii)	Insulation resistance (Class H5 only)	NOT APPLICABLE	
(viii)	Voltage proof	As in 15.11. For proof voltages see Schedule B on page 22	As specified
15.22	ENDURANCE, MECHANICAL	As specified. 500 operations, under 'Atmospheric Conditions for Measurement'	
(i)	Visual examination	As specified	As specified
(ii)	Engagement and disengagement force	As in 15.4	By hand
(iii)	Contact holding force	As in 15.5 (without sizing)	As specified
15.23	ENDURANCE, HIGH TEMPERATURE (Long and short term)	As specified. (All specimens long term only)	
15.23.1	Long term (All specimens)	All contacts to be linked in series with short lengths of suitable conductor. Ambient temperature 85°C. Current 3A, 5A, 19A, 35A, or 60A as rated. Duration of test 1000 hours	
(i)	Sealing (hot)	As specified	As specified
(ii)	Insulation resistance (hot)	As specified Method B.	Measurements to be recorded
(iii)	Contact resistance	As in 15.7	Maximum - initial reading plus 5 milliohms
(iv)	Shell continuity	As in 15.8	Maximum - initial reading plus 5 milliohms

TEST NO DEF STAN 59 - 35 (PART 1)	TITLE	DESCRIPTION	REQUIREMENTS
15.23.1 (contd)			
(v)	Voltage proof	As in 15.11. For proof voltages see Schedule B on page 22	As specified
(vi)	Sealing	As in 15.6	As specified
15.23.2	Short term	NOT APPLICABLE	
15.24	PLATING PROVING	NOT APPLICABLE	
15.25	SHELF LIFE	NOT APPLICABLE	
15.26	MOULD GROWTH	As specified	
(i)	Insulation resistance	As in 15.9 Method A	Minimum - 50 Megohms
(ii)	Visual examination	As specified	As specified
15.27	SALT MIST	As specified	
(i)	Contact resistance	As in 15.7	Maximum - initial reading plus 5 milliohms
(ii)	Shell continuity	As in 15.8	Maximum - initial reading plus 5 milliohms
(iii)	Engagement and disengagement force	As in 15.4	By hand
(iv)	Insulation resistance	As in 15.9 Method A	Minimum - 10 Megohms
(v)	Working voltage application	As specified. For working voltages see Schedule B on page 22	As specified
(vi)	Visual examination	As specified	As specified

DEF STAN 59 - 12 (PART 1)
SECTION 2/1

TEST NO DEF STAN 59 - 35 (PART 1)	TITLE	DESCRIPTION	REQUIREMENTS
15.27 (contd) (vii) (viii) (ix) (x) (xi)	Disengagement and engagement Insulation resistance Contact resistance Shell continuity Voltage proof	As specified As in 15.9 Method A As in 15.7 As in 15.8 As in 15.11. For proof voltages see Schedule B on page 22	By hand Minimum - 100 Megohms Maximum - initial reading plus 5 milliohms Maximum - initial reading plus 5 milliohms As specified
15.28 (i) (ii) (iii)	DUST Contact resistance Visual examination Engagement and disengagement force	As specified As in 15.7 As specified As in 15.4	Maximum - initial reading plus 5 milliohms As specified By hand
15.29	ROBUSTNESS OF TERMINATIONS	As specified. Test 50% of the contacts but not more than 6. Applied force, size 20 contacts (1 mm diameter) 22 newtons (5 lbf approx) for all larger sizes, 45 newtons (10 lbf approx)	As specified
15.30	CONTACT RETENTION (in insert)	As specified. Test 50% of the contacts but not more than 6, (different from those used for 15.29). Applied force, 45 newtons (10 lbf approx)	As specified
15.31 (i)	INSERT RETENTION (in shell) Sealing	As specified. Applied force, 220 newtons (50 lbf approx) for 5 seconds As in 15.6	As specified As specified

DEF STAN 59 - 35 (PART 1)
SECTION 2/1

TEST NO DEF STAN 59 - 35 (PART 1)	TITLE	DESCRIPTION	REQUIREMENTS
15.35	SOLVENT RESISTANCE	Types A4, B4, and C4 Test with all solvents listed in DEF STAN 59-35 (PART 1) Annex D, Sections 1 and 2 with the exception of f (Skydrol 500A) and h (XG 278). Immersion in solvents listed in Section 2 shall be for a period of 5 to 6 minutes	
(i)	Insulation resistance	As in 15.9 Method A	Minimum 5000 Megohms
15.35.1	Immersion and temperature cycling	As specified	
15.35.1.1	Cycle 1	As specified	
(i)	Engagement and disengagement	As specified	By hand
(ii)	Engagement and disengagement	As specified	By hand
15.35.1.2	Cycles 2 to 5	As specified	
(i)	Insulation resistance	As in 15.9 Method A	Minimum 100 Megohms
	Cycles 6 to 10	As specified	
(i)	Insulation resistance	As in 15.9 Method A	Minimum 100 Megohms
15.35.1.3	Cycles 11 to 15	As specified	
(i)	Insulation resistance	As in 15.9 Method A	Minimum 100 Megohms
15.35.2	Immersion	As specified	
(i)	Engagement and disengagement	As specified	By hand
(ii)	Engagement and disengagement	As specified	By hand
(iii)	Insulation resistance	As in 15.9 Method A	Minimum 100 Megohms

TEST NO DEF STAN 59 - 35 (PART 1)	TITLE	DESCRIPTION	REQUIREMENTS
15.36	CONTACT STRENGTH (1 mm dia and smaller male contacts only)	As specified load - 0.9 kg \pm 28 g (2 lb \pm 1 oz) using fixture as shown on page 25	Permanent set not to exceed 130 mm (0.005 in approx.)

10. TECHNICAL NOTES

1. Mating items. The free male shell items mate with the appropriate fix female shell items. The free female shell items mate with the appropriate free male shell items, for cable-coupling applications.
2. Fittings: shields, electrical, (straight or angled) and fittings should be ordered separately according to the cable used. Assembly details are shown in the drawings on pages 78-85. The angled shield may be assembled to the plug-socket in any one of the eight angular positions.

11. CLASSIFICATION

SCHEDULE A

Type	A4	B4	C4
Temperature	T4	T4	T4
Humidity	H6	H6	H6
DEF-5011	GP3	GP2	GP2
Shock	S2	S2	S2
Air density (low)	D2	D1	D1

12. RATINGS

Current. As shown in Tables IA - IM.

Voltage. The d.c. working voltage at sea level is shown against each item in the standard range Tables IA - IM, the appropriate ratings for other applications are shown in the following table:

SCHEDULE B

Application	Sea level			300 mb @ 20°C 8500 m (27 800 ft)(D1)			10.67 mb @ 20°C 30 480 m (100 000 ft)(D2)		
	500	1500	2500	350	1200	2000	100	120	200
D.C. working	500	1500	2500	350	1200	2000	100	120	200
A.C. working (r.m.s. 45-60 Hz)	350	1070	1780	250	850	1420	70	80	135
Proof (d.c. or peak)	2000	4000	6500	1700	3000	5000	200	250	420

Note: The voltage ratings are between adjacent contacts to the shell.

PLUGS AND SOCKETS ELECTRICAL PATTERN 104

DEF STAN 59 - 35 (PART 1)
SECTION 2/1

CONTACT SIZING AND HOLDING FORCE GAUGES AND TEST PRODS

FIGS 1
FIGS 2
FIG 3
PAGE 2/4

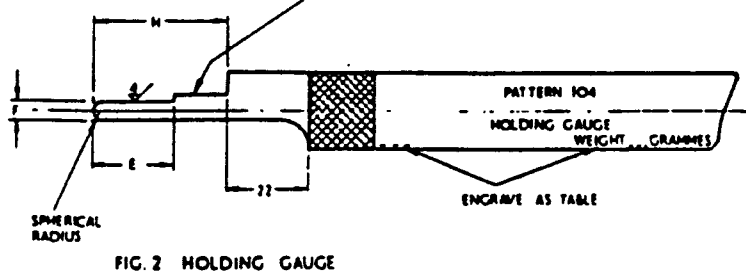
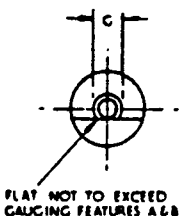
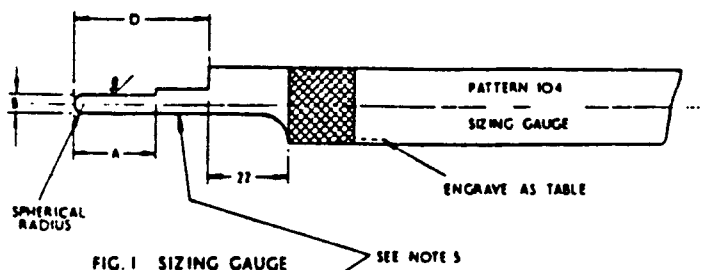
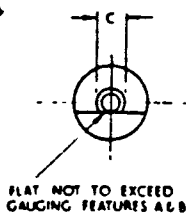

CONTACTS	FIG 1 SIZING GAUGE					FIG 2 HOLDING GAUGE					
	DIMENSIONS				ENGRAVING	DIMENSIONS				ENGRAVING	
	A	B	C	D		E	F	G	H	DIMN	WEIGHT
3 AMP	250 ± .005	0.410 + 0 - .0002	0.800 + .0006 - 0	370 ± .005	.041	.140 + .010 - 0	.0390 + .0007 - 0	.0800 + .0006 - 0	.370 ± .005	.039	35 g
5 AMP	250 ± .005	0.650 + 0 - .0004	0.800 + .0006 - 0	.370 ± .005	.065	.140 + .010 - 0	.0640 + .0006 - 0	.0800 + .0006 - 0	.370 ± .005	.064	57 g
19 AMP	.250 ± .005	.103 + 0 - .0004	.120 + .001 - 0	.370 ± .005	.103	.140 + .010 - 0	.102 + .0004 - 0	.120 + .001 - 0	.370 ± .005	.102	142 g
35 AMP	.250 ± .005	.143 + 0 - .0004	.160 + .001 - 0	.370 ± .005	.143	.140 + .010 - 0	.142 + .0004 - 0	.160 + .001 - 0	.370 ± .005	.142	180 g
60 AMP	.250 ± .005	.190 + 0 - .0004	.210 + .001 - 0	.370 ± .005	.190	.140 + .010 - 0	.189 + .0004 - 0	.210 + .001 - 0	.370 ± .005	.189	200 g

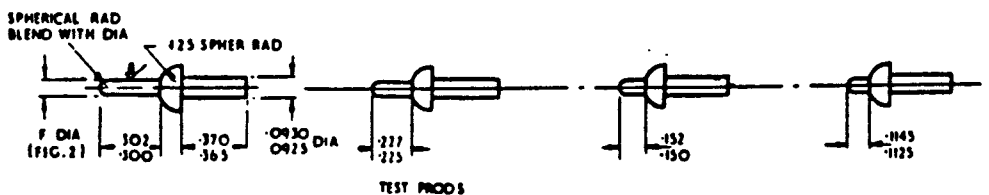

TEST PRODS
THE LENGTH OF PROD AND F DIA VARY. ALL OTHER DIMENSIONS AS LM. ILLUSTRATION
(The tool to be used in conjunction with these test prods is shown in DEF. STAN 59-35 (Part 1) Annex C)

FIG. 3 TEST PRODS

- NOTES:-
1. GAUGING FEATURES TO BE HARDENED ✓ = HARDEN, TEMPER, GRIND AND LAP 650 HV20
 2. MATERIAL: GAUGE STEEL, ALL SHARP EDGES TO BE REMOVED
 3. THESE GAUGES TO BE USED FOR TESTING FULLY ASSEMBLED COMPONENTS ONLY
 4. TOLERANCES IN RESPECT OF WEIGHT SHALL BE ± 1 GRAMME
 5. SHANK DIAMETER TO BE SUCH AS WILL PERMIT UNRESTRICTED ACCESS OF GAUGE

FIXTURE FOR CONTACT STRENGTH TEST

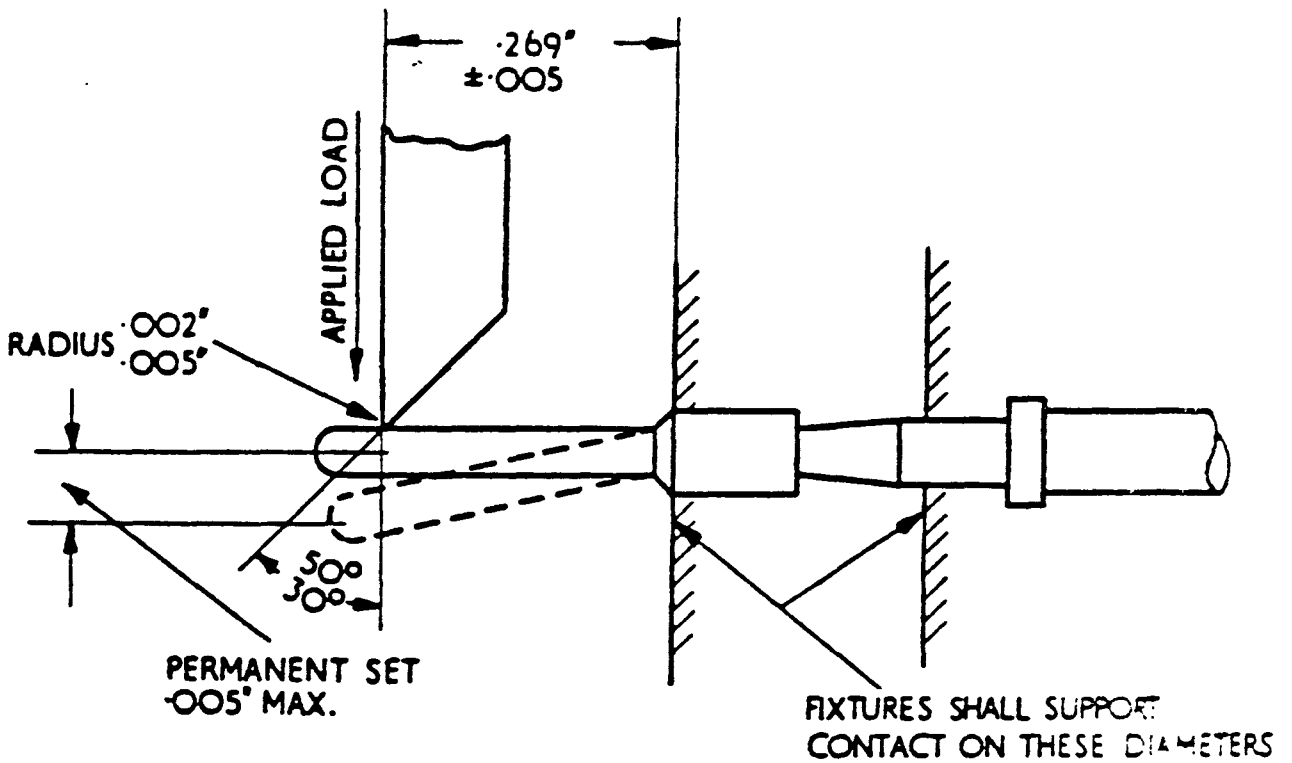

CONTACT STRENGTH TEST

PLUGS AND SOCKETS, ELECTRICAL, PATTERN 104
PERMISSIBLE ORIENTATIONS SHELL SIZE 1

ORIENTATION	2 CONTACT		3 CONTACT		4 CONTACT		6 CONTACT		12 CONTACT	
	PLUG	SOCKET	PLUG	SOCKET	PLUG	SOCKET	PLUG	SOCKET	PLUG	SOCKET
0										
1			THESE ORIENTATIONS ARE NOT TO BE PROVIDED							
2										
3										
4										
5										

Notes applicable to above are on page 73.

PLUGS AND SOCKETS, ELECTRICAL, PATTERN 104
PERMISSIBLE ORIENTATIONS SHELL SIZE 2

ORIENTATION	2 CONTACT		4 CONTACT		5 CONTACT		12 CONTACT		25 CONTACT	
	PLUG	SOCKET	PLUG	SOCKET	PLUG	SOCKET	PLUG	SOCKET	PLUG	SOCKET
0										
1										
2										
3										
4										
5										

Notes applicable to above are on page 73.

PLUGS AND SOCKETS, ELECTRICAL, PATTERN 104
PERMISSIBLE ORIENTATIONS SHELL SIZE 3

ORIENTATION	4 CONTACT		5 CONTACT		6 CONTACT		9 CONTACT	
	PLUG	SOCKET*	PLUG	SOCKET	PLUG	SOCKET	PLUG	SOCKET
0								
1								
2								
3								
4								
5								

Notes applicable to above are on page 73.

PLUGS AND SOCKETS, ELECTRICAL, PATTERN 104
PERMISSIBLE ORIENTATIONS SHELL SIZE 3

ORIENTATION	18 CONTACT		25 CONTACT		37 CONTACT		62 CONTACT	
	PLUG	SOCKET	PLUG	SOCKET	PLUG	SOCKET	PLUG	SOCKET*
0								
1								
2								
3								
4								
5								

Notes applicable to above are on page 73.

TABLE 1(A)
STANDARD RANGE
PLUGS, ELECTRICAL
ALUMINIUM FIXED, FEMALE SHELL, FINE THREAD

SHELL SIZE - NO OF CONTACTS		1 - 2		1 - 3		1 - 4		1 - 6		1 - 12	
Contact layout (Orientation 0)											
TEMPERATURE	ORIENTATION	STYLE REF	NATO STOCK NO	STYLE REF	NATO STOCK NO	STYLE REF	NATO STOCK NO	STYLE REF	NATO STOCK NO	STYLE REF	NATO STOCK NO
T _a -55/+100°C	0	PO4ALX1-2/ /0	5935-99- 013-0525	PO4ALX1-3/ /0	5935-99- 013-0537	PO4ALX1-4/ /0	5935-99- 013-0541	PO4ALX1-6/ /0	5935-99- 013-0553	PO4ALX1-12/ /0	5935-99- 014-8636
	1	/1	013-0526	-	-	/1	013-0542	/1	013-0554	/1	014-8637
	2	/2	013-0527	-	-	/2	013-0543	/2	013-0555	/2	014-8638
	3	/3	013-0528	-	-	/3	013-0544	/3	013-0556	/3	014-8639
	4	/4	013-0529	-	-	/4	013-0545	/4	013-0557	/4	014-8640
	5	/5	013-0530	/5	013-0538	/5	013-0546	/5	013-0558	/5	014-8641
Drawing number		CC/C/1010		CC/C/1011		CC/C/1012		CC/C/1013		CC/C1373	
Max. weight (grams)		28		27		28		28		26	
Current rating at max. temp (ampere/contact)	Cables: DEF STAN 61-12 (PART 5)	16		2.5		2.5		2.5		-	
	DEF STAN 61-12 (PART 4)	-		-		-		-		2	
	Open-wiring	19		5		5		5		3.5	
d.c. working voltage (sea level)		500		500		500		500		500	

Notes applicable to this Table are on page 73.

TABLE I(A) - CONTINUED

SHELL SIZE - NO OF CONTACTS		2 - 2		2 - 4		2 - 6		2 - 12		2 - 26	
Contact layout (Orientation 0)											
TEMPERATURE	ORIENTATION	STYLE REF	NATO STOCK NO	STYLE REF	NATO STOCK NO	STYLE NO	NATO STOCK NO	STYLE REF	NATO STOCK NO	STYLE REF	NATO STOCK NO
T _h -55/+100°D	0	POLALX2-2/ /0	5935-99- 014-8642	POLALX2-4/ /0	5935-99- 013-0565	POLALX2-6/ /0	5935-99- 013-0577	POLALX2-12/ /0	5935-99- 013-0589	POLALX2-26/ /0	5935-99- 014-8648
	1	/1	014-8643	/1	013-0566	/1	013-0578	/1	013-0590	/1	014-8649
	2	/2	014-8644	/2	013-0567	/2	013-0579	/2	013-0591	/2	014-8650
	3	/3	014-8645	/3	013-0568	/3	013-0580	/3	013-0592	/3	014-8651
	4	/4	014-8646	/4	013-0569	/4	013-0581	/4	013-0593	/4	014-8652
	5	/5	014-8647	/5	013-0570	/5	013-0582	/5	013-0594	/5	014-8653
Drawing number		CC/C/1381		CC/C/1014		CC/C/1015		CC/C/1016		CC/C/1373	
Max. weight (gramme)		38		39		36		41		38	
Current rating at max. temp (ampere/contact)	Cables: DEF STAN 61-42 (PART 5)	-		16		2.5		2.5		-	
	DEF STAN 61-12 (PART 4)	-		-		-		-		2	
	Open-wiring	35		19		5		5		3.5	
d.c. working voltage (sea level)		500		500		1500		500		500	

Notes applicable to this Table are on page 15.

TABLE I (A) - CONTINUED

DEF STAN 61-12 (PART 1)
 SECTION 1
 TABLE I(A) (CONT)

SHELL SIZE - NO OF CONTACTS		3 - 18		3 - 25		3 - 37		3 - 62	
Contact layout (Orientation 0)									
TEMPERATURE	ORIENTATION	STYLE REF	NATO STOCK NO	STYLE REF	NATO STOCK NO	STYLE REF	NATO STOCK NO	STYLE REF	NATO STOCK NO
T ₄ -55/+100°C	0	POLALIX-18/ /0	5935-99- 013-0601	POLALIX-25/ /0	5935-99- 013-0613	POLALIX-37/ /0	5935-99- 014-8654	POLALIX-62/ /0	5935-99- 014-8660
	1	/1	013-0602	/1	013-0614	/1	014-8655	/1	014-8661
	2	/2	013-0603	/2	013-0615	/2	014-8656	/2	014-8662
	3	/3	013-0604	/3	013-0616	/3	014-8657	/3	014-8663
	4	/4	013-0605	/4	013-0617	/4	014-8658	/4	014-8664
5	/5	013-0606	/5	013-0618	/5	014-8659	/5	014-8665	
Drawing number		CC/C/1017		CC/C/1018		CC/C/1375		CC/C/1375	
Max. weight (grams)		73		76		72		77	
Current rating at max. temp (ampere/contact)	Cables: DEF STAN 61-12 (PART 5)	2.5		2.5		-		-	
	DEF STAN 61-12 (PART 4)	-		-		2		2	
	Open-wiring	5		5		3.5		3.5	
d.c. working voltage (sea level)		500/1500 See note on page 73		500		500		500	

Notes applicable to this Table are on page 73.

TABLE I(B)
STANDARD RANGE
PLUGS, ELECTRICAL
ALUMINIUM, FREE, MALE SHELL, FINE THREAD

SHELL SIZE - NO OF CONTACTS		1 - 2		1 - 3		1 - 4		1 - 6		1 - 12	
Contact layout (Orientation 0)											
TEMPERATURE	ORIENTATION	STYLE REF	NATO STOCK NO	STYLE REF	NATO STOCK NO	STYLE REF	NATO STOCK NO	STYLE REF	NATO STOCK NO	STYLE REF	NATO STOCK NO
T _a -55/+100°C	0	POL AL P1-2/ /0	5935-99- 013-0625	POL AL P1-3/ /0	5935-99- 013-0637	POL AL P1-4/ /0	5935-99- 013-0641	POL AL P1-6/ /0	5935-99- 013-0653	POL AL P1-12/ /0	5935-99- 014-8646
	1	/1	013-0626	-	-	/1	013-0642	/1	013-0654	/1	014-8467
	2	/2	013-0627	-	-	/2	013-0643	/2	013-0655	/2	014-8668
	3	/3	013-0628	-	-	/3	013-0644	/3	013-0656	/3	014-8669
	4	/4	013-0629	-	-	/4	013-0645	/4	013-0657	/4	014-8670
	5	/5	013-0630	013-0638	/5	013-0638	/5	013-0646	/5	013-0658	/5
Drawing number		CC/C/1001		CC/C/1002		CC/C/1003		CC/C/1004		CC/C/1371	
Max. weight (gramme)		25		24		25		26		25	
Current rating at max. temp (ampere/contact)	Cables: DEF STAN 61-12 (PART 5)	16		2.5		2.5		2.5		-	
	DEF STAN 61-12 (PART 5)	-		-		-		-		2	
	Open-wiring	19		5		5		5		3.5	
Ins. working voltage (V rms)		500		500		500		500		500	

Note: applicable to this Table are on page 73.

DEF STAN 61-12-5
 SECTION 27
 TABLE I(B)

TABLE 1(B) - CONTINUED

SHELL SIZE - NO OF CONTACTS		2 - 2		2 - 4		2 - 6		2 - 12		2 - 26	
Contact layout (Orientation 0)											
TEMPERATURE	ORIENTATION	STYLE REF	NATO STOCK NO	STYLE REF	NATO STOCK NO	STYLE REF	NATO STOCK NO	STYLE REF	NATO STOCK NO	STYLE REF	NATO STOCK NO
T ₄ -55/+100°C	0	POLALP2-2/ /0	5935-99- 014-8672	POLALP2-4/ /0	5935-99- 013-0665	POLALP2-6/ /0	5935-99- 013-0677	POLALP2-12/ /0	5935-99- 013-0689	POLALP2-26/ /0	5935-99- 014-8674
	1	/1	014-8673	/1	013-0666	/1	013-0678	/1	013-0690	/1	014-8673
	2	/2	014-8674	/2	013-0667	/2	013-0679	/2	013-0691	/2	014-8680
	3	/3	014-8675	/3	013-0668	/3	013-0680	/3	013-0692	/3	014-8681
	4	/4	014-8676	/4	013-0669	/4	013-0681	/4	013-0693	/4	014-8682
	5	/5	014-8677	/5	013-0670	/5	013-0682	/5	013-0694	/5	014-8683
Drawing number		CC/C/1380		CC/C/1005		CC/C/1006		CC/C/1007		CC/C/1371	
Max. weight (gramme)		37		37		35		37		37	
Current rating at max. temp (ampere/contact)	Cables: DEF STAN 61-12 (PART 5)	-		16		2.5		2.5		-	
	DEF STAN 61-12 (PART 4)	-		-		-		-		2	
	Open-wiring	35		19		5		5		3.5	
d.c. working voltage (sea level)		500		500		1500		500		500	

Notes applicable to this Table are on page 7.

-4-

TABLE I(B) - CONTINUED

SHELL SIZE - NO OF CONTACTS		3 - 18		3 - 25		3 - 37		3 - 62	
Contact layout (Orientation 0)									
TEMPERATURE	ORIENTATION	STYLE REF	NATO STOCK NO	STYLE REF	NATO STOCK NO	STYLE REF	NATO STOCK NO	STYLE REF	NATO STOCK NO
T ₄ -55/+100°C	0	POLALP3-18/ /0	5935-99- 013-0701	POLALP3-25/ /0	5935-99- 013-0713	POLALP3-37/ /0	5935-99- 014-8684	POLALP3-62/ /0	5935-99- 014-8690
	1	/1	013-0702	/1	013-0714	/1	014-8685	/1	014-8691
	2	/2	013-0703	/2	013-0715	/2	014-8686	/2	014-8692
	3	/3	013-0704	/3	013-0716	/3	014-8687	/3	014-8693
	4	/4	013-0705	/4	013-0717	/4	014-8688	/4	014-8694
	5	/5	013-0706	/5	013-0718	/5	014-8689	/5	014-8695
Drawing number		CC/C/1008		CC/C/1009		CC/C/1371		CC/C/1371	
Max. weight (gramme)		71		74		70		77	
Current rating at max. temp (ampere/contact)	Cables: DEF STAN 61-12 (PART 5)	2.5		2.5		-		-	
	DEF STAN 61-12 (PART 4)	-		-		2		2	
	Open-wiring	5		5		3.5		3.5	
d.c. working voltage (sea level)		500/1500 See note on page 73		500		500		500	

Notes applicable to this Table are on page 73.

DEF STAN 59-25 (PART 1)
SECTION 7/1
TABLE I(B) (CONT.)

TABLE 1(C)
STANDARD RANGE
PLUGS, ELECTRICAL
ALUMINIUM, FREE, FEMALE SHELL (COUPLER), FINE THREAD

SHELL SIZE - NO OF CONTACTS		1 - 2		1 - 3		1 - 4		1 - 6		1 - 12	
Contact layout (Orientation U)											
TEMPERATURE	ORIENTATION	STYLE REF	NATO STOCK NO	STYLE REF	NATO STOCK NO	STYLE REF	NATO STOCK NO	STYLE REF	NATO STOCK NO	STYLE REF	NATO STOCK NO
T ₄ -55/+100°C	0	PO4A4C1-2/ /0	5935-99- 013-0725	PO4A4C1-3/ /0	5935-99- 013-0737	PO4A4C1-4/ /0	5935-99- 013-0741	PO4A4C1-6/ /0	5935-99- 013-0753	PO4A4C1-12/ /0	5935-99- 014-8696
	1	/1	013-0726	-	-	/1	013-0742	/1	013-0754	/1	014-8697
	2	/2	013-0727	-	-	/2	013-0743	/2	013-0755	/2	014-8698
	3	/3	013-0728	-	-	/3	013-0744	/3	013-0756	/3	014-8699
	4	/4	013-0729	-	-	/4	013-0745	/4	013-0757	/4	014-8700
	5	/5	013-0730	/5	013-0738	/5	013-0746	/5	013-0758	/5	014-8701
Drawing number		CC/C/1074		CC/C/1075		CC/C/1076		CC/C/1077		CC/C/1372	
Max. weight (gramme)		26		25		26		26		27	
Current rating at max. temp (ampere/contact)	Cables: DEF STAN 61-12 (PART 5)	16		2.5		2.5		2.5		-	
	DEF STAN 61-12 (PART 4)	-		-		-		-		2	
	Open-wiring	19		5		5		5		3	
d.c. working voltage (sea level)		500		500		500		500		500	

Notes applicable to this Table are on page 73.

TABLE I(C) - CONTINUED

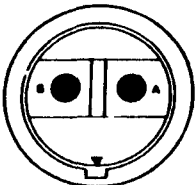
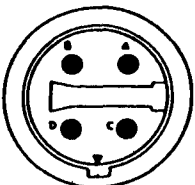
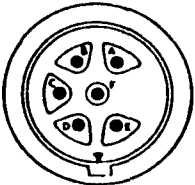
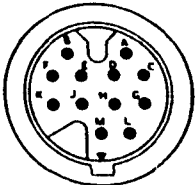
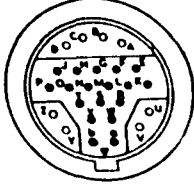
SHELL SIZE - NO OF CONTACTS		2 - 2		2 - 4		2 - 6		2 - 12		2 - 26	
Contact layout (Orientation 0)											
TEMPERATURE	ORIENTATION	STYLE REF	NATO STOCK NO	STYLE REF	NATO STOCK NO	STYLE REF	NATO STOCK NO	STYLE REF	NATO STOCK NO	STYLE REF	NATO STOCK NO
T _h -55/+100°C	0	POLALC2-2/ /0	5935-99- 014-8702	POLALC2-4/ /0	5935-99- 013-0765	POLALC2-6/ /0	5035-99- 013-0777	POLALC2-12/ /0	5935-99- 013-0789	POLALC2-26/ /0	5935-99- 014-8708
	1	/1	014-8703	/1	013-0766	/1	013-0778	/1	013-0790	/1	014-8709
	2	/2	014-8704	/2	013-0767	/2	013-0779	/2	013-0791	/2	014-8710
	3	/3	014-8705	/3	013-0768	/3	013-0780	/3	013-0792	/3	014-8711
	4	/4	014-8706	/4	013-0769	/4	013-0781	/4	013-0793	/4	014-8712
	5	/5	014-8707	/5	013-0770	/5	013-0782	/5	013/0794	/5	014-8713
Drawing number		CC/C/1382		CC/C/1078		CC/C/1079		CC/C/1080		CC/C/1372	
Max. weight (gramme)		38		38		37		39		39	
Current rating at max. temp (ampere/contact)	Cables: DEF STAN 61-12 (PART 5)	-		16		2.5		2.5		-	
	DEF STAN 61-12 (PART 4)	-		-		-		-		2	
	Open-wiring	35		19		5		5		3.5	
Max. working voltage (open level)		500		500		1500		500		500	

Notes applicable to this Table are on page 75.

DEF STAN 61-12
SECTION 2/1
TABLE I(C)(CONTD)

TABLE I(C) - CONTINUED

DEF STAN 61-12 (PART 1)
SECTION 71
TABLE I(C) (CONT'D)

SHELL SIZE - NO OF CONTACTS		3 - 18		3 - 25		3 - 37		3 - 62	
Contact layout (Orientation 0)									
TEMPERATURE	ORIENTATION	STYLE REF	NATO STOCK NO	STYLE REF	NATO STOCK NO	STYLE REF	NATO STOCK NO	STYLE REF	NATO STOCK NO
T _a -55/+100°C	0	POLALC3-18/ /0	5935-99- 013-0801	POLALC3-25/ /0	5935-99- 013-0813	POLALC3-37/ /0	5935-99- 014-8714	POLALC3-62/ /0	5935-99- 014-8720
	1	/1	013-0802	/1	013-0814	/1	014-8715	/1	014-8721
	2	/2	013-0803	/2	013-0815	/2	014-8716	/2	014-8722
	3	/3	013-0804	/3	013-0816	/3	014-8717	/3	014-8723
	4	/4	013-0805	/4	013-0817	/4	014-8718	/4	014-8724
	5	/5	013-0806	/5	013-0818	/5	014-8719	/5	014-8725
Drawing number		CC/C/1081		CC/C/1082		CC/C/1372		CC/C/1372	
Max. weight (gramme)		67		71		71		77	
Current rating at max. temp (ampere/contact)	Cables: DEF STAN 61-12 (PART 5)	2.5		2.5		-		-	
	DEF STAN 61-12 (PART 4)	-		-		2		2	
	Open-wiring	5		5		3.5		3.5	
d.c. working voltage (sea level)		500-1500 See note on page 73		500		500		500	

Notes applicable to this Table are on page 73.

- 44 -

TABLE I (D)

STANDARD RANGE

SOCKETS, ELECTRICAL

ALUMINIUM, FIXED, FEMALE SHELL, FINE THREAD

SHELL SIZE - NO OF CONTACTS		1 - 2		1 - 3		1 - 4		1 - 6		1 - 12	
Contact layout (Orientation 0)											
TEMPERATURE	ORIENTATION	STYLE REF	NATO STOCK NO	STYLE REF	NATO STOCK NO	STYLE REF	NATO STOCK NO	STYLE REF	NATO STOCK NO	STYLE REF	NATO STOCK NO
T ₄ -55/+100°C	0	S04ALX1-2/ /0	5935-99- 013-0825	S04ALX1-3/ /0	5935-99- 013-0837	S04ALX1-4/ /0	5935-99- 013-0841	S04ALX1-6/ /0	5935-99- 013-0853	S04ALX1-12/ /0	5935-99- 013-0871
	1	/1	013-0826	-	-	/1	013-0842	/1	013-0854	/1	013-0872
	2	/2	013-0827	-	-	/2	013-0843	/2	013-0855	/2	013-0873
	3	/3	013-0828	-	-	/3	013-0844	/3	013-0856	/3	013-0874
	4	/4	013-0829	-	-	/4	013-0845	/4	013-0857	/4	013-0875
	5	/5	013-0830	/5	013-0835	/5	013-0846	/5	013-0858	/5	013-0876
Drawing number		CC/C/1010		CC/C/1011		CC/C/1012		CC/C/1013		CC/C/1377	
Max. weight (gramme)		28		27		28		28		26	
Current rating at max. temp (ampere/contact)	Cables: DEF STAN 61-12 (PART 5)	16		2.5		2.5		2.5		-	
	DEF STAN 61-12 (PART 4)	-		-		-		-		2	
	Open-wiring	19		5		5		5		3.5	
Working voltage (sea level)		500		500		500		500		500	

Notes applicable to this Table are on page 73.

013-0877
 013-0878
 013-0879
 013-0880
 013-0881
 013-0882
 013-0883
 013-0884
 013-0885
 013-0886
 013-0887
 013-0888
 013-0889
 013-0890
 013-0891
 013-0892
 013-0893
 013-0894
 013-0895
 013-0896
 013-0897
 013-0898
 013-0899
 013-0900

TABLE I(D) - CONTINUED

DEF STAN 59-35 (PART 1)
SECTION 2/1
TABLE I(D)(CONTD)

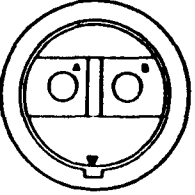
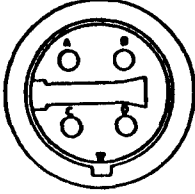
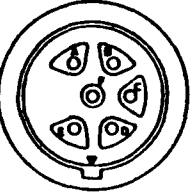
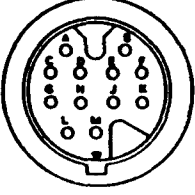
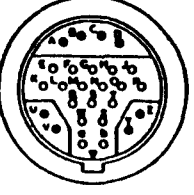
SHELL SIZE - NO OF CONTACTS		2 - 2		2 - 4		2 - 6		2 - 12		2 - 26	
Contact layout (Orientation 0)											
TEMPERATURE	ORIENTATION	STYLE REF	NATO STOCK NO	STYLE REF	NATO STOCK NO	STYLE REF	NATO STOCK NO	STYLE REF	NATO STOCK NO	STYLE REF	NATO STOCK NO
T ₄ -55/+100°C	0	SO4ALX2-2/ /0	5935-99- 014-8732	SO4ALX2-4/ /0	5935-99- 013-0865	SO4ALX2-6/ /0	5935-99- 013-0877	SO4ALX2-12/ /0	5935-99- 013-0889	SO4ALX2-26/ /0	5935-99- 014-8738
	1	/1	014-8733	/1	013-0866	/1	013-0878	/1	013-0890	/1	014-8739
	2	/2	014-8734	/2	013-0867	/2	013-0879	/2	013-0891	/2	014-8740
	3	/3	014-8735	/3	013-0868	/3	013-0880	/3	013-0892	/3	014-8741
	4	/4	014-8736	/4	013-0869	/4	013-0881	/4	013-0893	/4	014-8742
	5	/5	014-8737	/5	013-0870	/5	013-0882	/5	013-0894	/5	014-8743
Drawing number		CC/C/1381		CC/C/1014		CC/C/1015		CC/C/1016		CC/C/1373	
Max. weight (grams)		38		39		36		41		38	
Current rating at max. temp (ampere/contact)	Cables: DEF STAN 61-12 (PART 5)	-		16		2.5		2.5		-	
	DEF STAN 61-12 (PART 4)	-		-		-		-		2	
	Open-wiring	35		19		5		5		3.5	
d.c. working voltage(sea level)		500		500		1500		500		500	

Notes applicable to this Table are on page 73.

TABLE I(D) - CONTINUED

SHELL SIZE - NO OF CONTACTS		3 - 18		3 - 25		3 - 37		3 - 62		
Contact layout (Orientation 0)										
TEMPERATURE	ORIENTATION	STYLE REF	NATO STOCK NO	STYLE REF	NATO STOCK NO	STYLE REF	NATO STOCK NO	STYLE REF	NATO STOCK NO	
T ₄ -55/+100°C	0	SO4ALX3-18/ /0	5935-99- 013-0901	SO4ALX3-25/ /0	5935-99- 013-0913	SO4ALX3-37/ /0	5935-99- 014-8744	SO4ALX3-62/ /0	5935-99- 014-8750	
	1	/1	013-0902	/1	013-0914	/1	014-8745	/1	014-8751	
	2	/2	013-0903	/2	013-0915	/2	014-8746	/2	014-8752	
	3	/3	013-0904	/3	013-0916	/3	014-8747	/3	014-8753	
	4	/4	013-0905	013-0905	/4	013-0917	/4	014-8748	/4	014-8754
	5	/5	013-0906	013-0906	/5	013-0918	/5	014-8749	/5	014-8755
Drawing number		CC/C/1017		CC/C/1018		CC/C/1373		CC/C/1373		
Max. weight (grams)		73		76		72		77		
Current rating at max. temp (ampere/contact)	Cables: DEF STAN 61-12 (PART 5)	2.5		2.5		-		-		
	DEF STAN 61-12 (PART 4)	-		-		2		2		
	Open-wiring	5		5		3.5		3.5		
d.c. working voltage(see level)		500/1500 See note on page 73		500		500		500		

Notes applicable to this Table are on page 73.

DEF STAN 61-12 (PART 5)
 DEF STAN 61-12 (PART 4)
 (CC/C/1373)

TABLE (E)
STANDARD RANGE
SOCKETS, ELECTRICAL
ALUMINIUM, FREE, MALE SHELL, FINE THREAD

SHELL SIZE - NO OF CONTACTS		1 - 2		1 - 3		1 - 4		1 - 6		1 - 12	
Contact layout (Orientation 0)											
TEMPERATURE	ORIENTATION	STYLE REF	NATO STOCK NO	STYLE REF	NATO STOCK NO	STYLE REF	NATO STOCK NO	STYLE REF	NATO STOCK NO	STYLE REF	NATO STOCK NO
T ₄ -55/+100°C	0	SO4ALP1-2/ /0	5935-99- 013-0925	SO4ALP1-3/ /0	5935-99- 013-0937	SO4ALP1-4/ /0	5935-99- 013-0941	SO4ALP1-6/ /0	5935-99- 013-0953	SO4ALP1-12/ /0	5935-99- 014-8756
	1	/1	013-0926	-	-	/1	013-0942	/1	013-0954	/1	014-8757
	2	/2	013-0927	-	-	/2	013-0943	/2	013-0955	/2	014-8758
	3	/3	013-0928	-	-	/3	013-0944	/3	013-0956	/3	014-8759
	4	/4	013-0929	-	-	/4	013-0945	/4	013-0957	/4	014-8760
5	/5	013-0930	013-0938	/5	013-0938	/5	013-0946	/5	013-0958	/5	014-8761
Drawing number		CC/C/1001		CC/C/1002		CC/C/1003		CC/C/1004		CC/C/1371	
Max. weight (gramme)		25		24		25		26		25	
Current rating at max. temp (ampere/contact)	Cables: DEF STAN 61-12 (PART 5)	16		2.5		2.5		2.5		-	
	DEF STAN 61-12 (PART 4)	-		-		-		-		2	
	Open-wiring	19		5		5		5		3.5	
d.c. working voltage (sea level)		500		500		500		500		500	

Notes applicable to this Table are on page 73.

42-

TABLE I (E) - CONTINUED

SHELL SIZE - NO OF CONTACTS		2 - 2		2 - 4		2 - 6		2 - 12		2 - 26	
Contact layout (Orientation 0)											
TEMPERATURE	ORIENTATION	STYLE REF	NATO STOCK NO	STYLE REF	NATO STOCK NO	STYLE REF	NATO STOCK NO	STYLE REF	NATO STOCK NO	STYLE REF	NATO STOCK NO
T ₄ -55/+100°C	0	SO4A.F2-2/ /0	5935-99- 014-8762	SO4A.F2-4/ /0	5935-99- 013-0965	SO4A.F2-6/ /0	5935-99- 013-0977	SO4A.F2-12/ /0	5935-99- 013-0989	SO4A.F2-26/ /0	5935-99- 014-8768
	1	/1	014-8763	/1	013-0966	/1	013-0978	/1	013-0990	/1	014-8769
	2	/2	014-8764	/2	013-0967	/2	013-0979	/2	013-0991	/2	014-8770
	3	/3	014-8765	/3	013-0968	/3	013-0980	/3	013-0992	/3	014-8771
	4	/4	014-8766	/4	013-0969	/4	013-0981	/4	013-0993	/4	014-8772
	5	/5	014-8767	/5	013-0970	/5	013-0982	/5	013-0994	/5	014-8773
Drawing number		CC/C/1380		CC/C/1005		CC/C/1006		CC/C/1007		CC/C/1371	
Max. weight (gramme)		37		37		35		38		37	
Current rating at max temp (ampere/contact)	Cables: DEF STAN 61-12 (PART 5)	-		16		2.5		2.5		-	
	DEF STAN 61-12 (PART 4)	-		-		-		-		2	
	Open-wiring	35		19		5		5		3.5	
d.c. working voltage (sea level)		500		500		1500		500		500	

Notes applicable to this Table are on page 73.

DEF STAN 59-35 (PA. 1)
SECTION 2/1
TABLE I (E)

TABLE I(E) - CONTINUED

DEF STAN 40-15 (PART 1)
 SECTION 7/1
 TABLE I(E)(CONT)

SHELL SIZE - NO OF CONTACTS		3 - 18		3 - 25		3 - 37		3 - 62	
Contact layout (Orientation 0)									
TEMPERATURE	ORIENTATION	STYLE REF	NATO STOCK NO	STYLE REF	NATO STOCK NO	STYLE REF	NATO STOCK NO	STYLE REF	NATO STOCK NO
T4 -55/+100°C	0	S04ALP3-18/ /0	5935-99- 013-1214	S04ALP3-25/ /0	5935-99- 013-1226	S04ALP3-37/ /0	5935-99- 014-8774	S04ALP3-62/ /0	5935-99- 014-8780
	1	/1	013-1215	/1	013-1227	/1	014-8775	/1	014-8781
	2	/2	013-1216	/2	013-1228	/2	014-8776	/2	014-8782
	3	/3	013-1217	/3	013-1229	/3	014-8777	/3	014-8783
	4	/4	013-1218	/4	013-1230	/4	014-8778	/4	014-8784
	5	/5	013-1219	/5	013-1231	/5	014-8779	/5	014-8785
Drawing number		CC/C/1008		CC/C/1009		CC/C/1371		CC/C/1371	
Max. weight (gramme)		71		74		70		77	
Current rating at max. temp (ampere/contact)	Cables: DEF STAN 61-12 (PART 5)	2.5		2.5		-		-	
	DEF STAN 61-12 (PART 4)	-		-		2		2	
	Open-wiring	5		5		3.5		3.5	
d.c. working voltage (sea level)		500/1500 See note on page 73		500		500		500	

* is applicable to this Table are on page 73.

TABLE I (F)

STANDARD RANGE

PLUGS, ELECTRICAL

BRASS, FIXED, FEMALE SHELL, COARSE THREAD

SHELL SIZE - NO.OF CONTACTS		1 - 2		1 - 3		1 - 4		1 - 6		1 - 12	
Contact layout (Orientation 0)											
TEMPERATURE	ORIENTATION	STYLE REF	NATO STOCK NO	STYLE REF	NATO STOCK NO	STYLE REF	NATO STOCK NO	STYLE REF	NATO STOCK NO	STYLE REF	NATO STOCK NO
T ₄ -55/+100°C	0	PO4.B4.X1-2/ /0	5935-99- 013-1238	PO4.B4.X1-3/ /0	5935-99- 013-1244	PO4.B4.X1-4/ /0	5935-99- 013-1246	PO4.B4.X1-6/ /0	5935-99- 013-1252	PO4.B4.X1-12/ /0	5935-99- 014-8746
	1	/1	013-1239	-	-	/1	013-1247	/1	013-1253	/1	014-8757
	2	/2	013-1240	-	-	/2	013-1248	/2	013-1254	/2	014-8788
	3	/3	013-1241	-	-	/3	013-1249	/3	013-1255	/3	014-8789
	4	/4	013-1242	-	-	/4	013-1250	/4	013-1256	/4	014-8790
	5	/5	013-1243	013-1243	/5	013-1245	/5	013-1251	/5	013-1257	/5
Drawing number		CC/C/1124		CC/C/1125		CC/C/1126		CC/C/1127		CC/C/1376	
Max. weight (gramme)		65		64		64		67		82	
Current rating at max. temp (ampere/contact)	Cables: DEF STAN 61-12 (PART 5)	16		2.5		2.5		2.5		-	
	DEF STAN 61-12 (PART 4)	-		-		-		-		2	
	Open-wiring	19		5		5		5		3.5	
d.c. working voltage(amp level)		500		500		500		500		500	

Notes applicable to this Table are on page 13.

DEF STAN 59-35 (PART 1)
 SECTION 2/1
 TABLE I (F)

TABLE I(P) - CONTINUED

DEF STAN 59-15 (PART 1)
 SECTION 2/1
 TABLE I(P) (CONTD)

SHELL SIZE - NO OF CONTACTS		2 - 2		2 - 4		2 - 6		2 - 12		2 - 26	
Contact layout (Orientation 0)											
TEMPERATURE	ORIENTATION	STYLE REF	NATO STOCK NO	STYLE REF	NATO STOCK NO	STYLE REF	NATO STOCK NO	STYLE REF	NATO STOCK NO	STYLE REF	NATO STOCK NO
T ₄ -55/+100°C	0	POL.B4.X2-2/ /0	5935-99- 014-8792	POL.B4.X2-4/ /0	5935-99- 013-1258	POL.B4.X2-6/ /0	5935-99- 013-1264	POL.B4.X2-12/ /0	5935-99- 013-1270	POL.B4.X2-26/ /0	5935-99- 014-8798
	1	/1	014-8793	/1	013-1259	/1	013-1265	/1	013-1271	/1	014-8799
	2	/2	014-8794	/2	013-1260	/2	013-1266	/2	013-1272	/2	014-8800
	3	/3	014-8795	/3	013-1261	/3	013-1267	/3	013-1273	/3	014-8801
	4	/4	014-8796	/4	013-1262	/4	013-1268	/4	013-1274	/4	014-8802
	5	/5	014-8797	/5	013-1263	/5	013-1269	/5	013-1275	/5	014-8803
Drawing number		CC/C/1397		CC/C/1128		CC/C/1129		CC/C/1130		CC/C/1376	
Max. weight (gramme)		91		92		90		95		125	
Current rating at max. temp (ampere/contact)	Cables: DEF STAN 61-12 (PART 5)	-		16		2.5		2.5		-	
	DEF STAN 61-12 (PART 4)	-		-		-		-		2	
	Open-wiring	35		19		5		5		3.5	
d.o. working voltage (sea level)		500		500		1500		500		500	

TABLE I (F) - CONTINUED

SHELL SIZE - NO OF CONTACTS		3 - 4		3 - 5		3 - 6		3 - 9	
Contact layout (Orientation 0)									
TEMPERATURE	ORIENTATION	STYLE REF	NATO STOCK NO	STYLE REF	NATO STOCK NO	STYLE REF	NATO STOCK NO	STYLE REF	NATO STOCK NO
T4 -55/+100°C	0	POLBLX3-4/ /0	5935-99- 013-1276	POLBLX3-5/ /0	5935-99- 014-8804	POLBLX3-6/ /0	5935-99- 013-1282	POLBLX3-9/ /0	5935-99- 013-1288
	1	/1	013-1277	/1	014-8805	/1	013-1283	/1	013-1289
	2	/2	013-1278	/2	014-8806	/2	013-1284	/2	013-1290
	3	/3	013-1279	/3	014-8807	/3	013-1285	/3	013-1291
	4	/4	013-1280	/4	014-8808	/4	013-1286	/4	013-1292
	5	/5	013-1281	/5	014-8809	/5	013-1287	/5	013-1293
Drawing number		CC/C/1131		CC/C/1132		CC/C/1195		CC/C/1133	
Max. weight (gramme)		166		166		155		164	
Current rating at max. temp (ampere/contact)	Cables: DEF STAN 61-12 (PART 5)	-		-		-		-	
	DEF STAN 61-12 (PART 4)	-		-		-		-	
	Open-wiring	A, B, and C - 60 D - 19		A and B - 60 C, D, and E - 19		19		19	
Max. working voltage (sea level)		500		500		2500		500	

Notes applicable to this Table are on page 15.

DEF STAN 59-15 (PART 4)
 SECTION 2/1
 TABLE I (F) (CONT.)

TABLE I (F) - CONTINUED

DEF STAN 59-35 (PART 1)
 SECTION 2/1
 TABLE I (F) (CONTD)

SHELL SIZE - NO OF CONTACTS		3 - 18		3 - 25		3 - 37		3 - 62	
Contact layout (Orientation 0)									
TEMPERATURE	ORIENTATION	STYLE REF	NATO STOCK NO	STYLE REF	NATO STOCK NO	STYLE REF	NATO STOCK NO	STYLE REF	NATO STOCK NO
T ₄ -55/+10C°	0	PO4B4X3-18/ /0	5935-99- 013-1294	PO4B4X3-25/ /0	5935-99- 013-1300	PO4B4X3-37/ /0	5935-99- 014-8810	PO4B4X3-62/ /0	5935-99- 014-8816
	1	/1	013-1295	/1	013-1301	/1	014-8811	/1	014-8817
	2	/2	013-1296	/2	013-1302	/2	014-8812	/2	014-8818
	3	/3	013-1297	/3	013-1303	/3	014-8813	/3	014-8819
	4	/4	013-1298	/4	013-1304	/4	014-8814	/4	014-8820
	5	/5	013-1299	/5	013-1305	/5	014-8815	/5	014-8821
Drawing number		CC/C/1134		CC/C/1135		CC/C/3176		CC/C/1376	
Max weight (grams)		159		159		169		175	
Current rating at max temp (ampere/contact)	Cables: DEF STAN 61-12 (PART 5)	2.5		2.5		-		-	
	DEF STAN 61-12 (PART 4)	-		-		2		2	
	Open-wiring	5		5		3.5		3.5	
d.c. working voltage (sea level)		500/1500 See note on page 73		500		500		500	

Notes applicable to this Table are on page 73.

TABLE I(G)

STANDARD RANGE

PLUGS, ELECTRICAL

BRASS, FREE, MALE SHELL, COARSE THREAD

SHELL SIZE - NO OF CONTACTS		1 - 2		1 - 3		1 - 4		1 - 5		1 - 12	
Contact layout (Orientation 0)											
TEMPERATURE	ORIENTATION	STYLE REF	NATO STOCK NO	STYLE REF	NATO STOCK NO	STYLE REF	NATO STOCK NO	STYLE REF	NATO STOCK NO	STYLE REF	NATO STOCK NO
T ₄ -55/+100°C	0	POL.BLP1-2/ /0	5935-99- 013-1306	POL.BLP1-3/ /0	5935-99- 013-1312	POL.BLP1-4/ /0	5935-99- 013-1314	POL.BLP1-5/ /0	5935-99- 013-1320	POL.BLP1-12/ /0	5935-99- 014-8822
	1	/1	013-1307	-	-	/1	013-1315	/1	013-1321	/1	014-8823
	2	/2	013-1308	-	-	/2	013-1316	/2	013-1322	/2	014-8824
	3	/3	013-1309	-	-	/3	013-1317	/3	013-1323	/3	014-8825
	4	/4	013-1310	-	-	/4	013-1318	/4	013-1324	/4	014-8826
5	/5	013-1311	013-1313	/5	013-1313	/5	013-1319	/5	013-1325	/5	014-8827
Drawing number		CC/C/1112		CC/C/1113		CC/C/1114		CC/C/1115		CC/C/1374	
Max. weight (gramme)		78		72		73		79		76	
Current rating at max. temp (ampere/contact)	Cables: DEF STAN 61-12 (PART 5)	16		2.5		2.5		2.5		-	
	DEF STAN 61-12 (PART 4)	-		-		-		-		2	
	Open-wiring	19		5		5		5		3.5	
d.c. working voltage (nom. level)		500		500		500		500		500	

Notes applicable to this Table are on page 75.

DEF STAN 59-15 (1962)
SECTION 2/1
TABLE I(G)

TABLE I(G) - CONTINUED

DEF STAN 59-35 (PART 1)
 SECTION 2/1
 TABLE I(G)(CONTR)

SHELL SIZE - NO OF CONTACTS		2 - 2		2 - 4		2 - 6		2 - 12		2 - 26	
Contact layout (Orientation 0)											
TEMPERATURE	ORIENTATION	STYLE REF	NATO STOCK NO	STYLE REF	NATO STOCK NO	STYLE REF	NATO STOCK NO	STYLE REF	NATO STOCK NO	STYLE REF	NATO STOCK NO
T ₄ -55/+100°C	0	PO4B4P2-2/ /0	5935-99- 014-8828	PO4B4P2-4/ /0	5935-99- 013-1326	PO4B4P2-6/ /0	5935-99- 013-1332	PO4B4P2-12/ /0	5935-99- 013-1338	PO4B4P2-26/ /0	5935-99- 014-8834
	1	/1	014-8829	/1	013-1327	/1	013-1333	/1	013-1339	/1	014-8835
	2	/2	014-8830	/2	013-1328	/2	013-1334	/2	013-1340	/2	014-8836
	3	/3	014-8831	/3	013-1329	/3	013-1335	/3	013-1341	/3	014-8837
	4	/4	014-8832	/4	013-1330	/4	013-1336	/4	013-1342	/4	014-8838
5	/5	014-8833	/5	013-1331	/5	013-1337	/5	013-1343	/5	014-8839	
Drawing number		CC/C/1402		CC/C/1116		CC/C/1117		CC/C/1118		CC/C/1374	
Max. weight (gramme)		103		106		102		103		124	
Current rating at max. temp (ampere/contact)	Cables: DEF STAN 61-12 (PART 5)	-		16		2.5		2.5		-	
	DEF STAN 61-12 (PART 4)	-		-		-		-		2	
	Open-wiring	35		19		5		5		3.5	
d.c. working voltage (sea level)		500		500		500		500		500	

Notes applicable to this Table are on page 73.

TABLE I(G) - CONTINUED

SHELL SIZE - NO OF		3 - 4		3 - 5		3 - 6		3 - 9	
Contact layout (Orientation 0)									
TEMPERATURE	ORIENTATION	STYLE REF	NATO STOCK NO	STYLE REF	NATO STOCK NO	STYLE REF	NATO STOCK NO	STYLE REF	NATO STOCK NO
T ₄ -55/+100 °C	0	PO4B4F3-4/ /0	5935-99- 013-1344	PO4B4F3-5/ /0	5935-99- 014-8840	PO4B4F3-6/ /0	5935-99- 013-1350	PO4B4F3-9/ /0	5935-99- 013-1356
	1	/1	013-1345	/1	014-8841	/1	013-1351	/1	013-1357
	2	/2	013-1346	/2	014-8842	/2	013-1352	/2	013-1358
	3	/3	013-1347	/3	014-8843	/3	013-1353	/3	013-1359
	4	/4	013-1348	/4	014-8844	/4	013-1354	/4	013-1360
	5	/5	013-1349	/5	014-8845	/5	013-1355	/5	013-1361
Drawing number		CC/C/1119		CC/C/1120		CC/C/1194		CC/C/1121	
Max. weight (gramme)		182		182		183		180	
Current rating at max. temp (ampere/contact)	Cables: DEF STAN 61-12 (PART 5)	-		-		-		-	
	DEF STAN 61-12 (PART 4)	-		-		-		-	
	Open-wiring	A, B, and C - 60 D - 19		A and B - 60 C, D, and E - 19		19		19	
d.c. working voltage (sea level)		500		500		2500		500	

Notes applicable to this Table are on page 75.

TABLE I(G) - CONTINUED

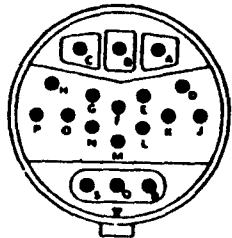
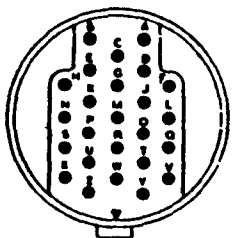
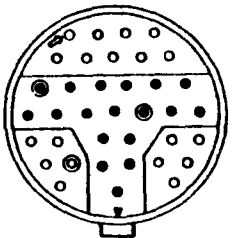
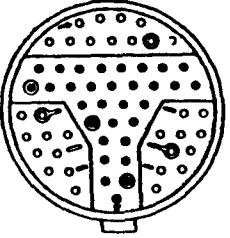
SHELL SIZE - NO OF CONTACTS		3 - 18		3 - 25		3 - 37		3 - 62	
Contact layout (Orientation 0)									
TEMPERATURE	ORIENTATION	STYLE REF	NATO STOCK NO	STYLE REF	NATO STOCK NO	STYLE REF	NATO STOCK NO	STYLE REF	NATO STOCK NO
T _h -55/+100°C	0	PO4.B4.P3-18/ /0	5935-99- 013-1362	PO4.B4.P3-25/ /0	5935-99- 013-1368	PO4.B4.P3-37/ /0	5935-99- 014-8846	PO4.B4.P3-62/ /0	5935-99- 014-8852
	1	/1	013-1363	/1	013-1369	/1	014-8847	/1	014-8853
	2	/2	013-1364	/2	013-1370	/2	014-8848	/2	014-8854
	3	/3	013-1365	/3	013-1371	/3	014-8849	/3	014-8855
	4	/4	013-1366	/4	013-1372	/4	014-8850	/4	014-8856
	5	/5	013-1367	/5	013-1373	/5	014-8851	/5	014-8857
Drawing number		CC/C/1122		CC/C/1123		CC/C/1374		CC/C/1374	
Max. weight (grams)		177		182		170		178	
Current rating at max. temp (ampere/contact)	Cables: DEF STAN 61-12 (PART 5)	2.5		2.5		-		-	
	DEF STAN 61-12 (PART 5)	-		-		2		2	
	Open-wiring	5		5		3.5		3.5	
d.c. working voltage (sea level)		500/1500 See note on page 73		500		500		500	

DEF STAN 59-35 (PART 1)
 SECTION 2/1
 TABLE I(G) (CONTD)

Notes applicable to this Table are on page 73.

TABLE I(H)

STANDARD RANGE

PLUGS, ELECTRICAL

BRASS, FREE, FEMALE SHELL(COUPLER), COARSE THREAD

SHELL SIZE - NO OF CONTACTS		1 - 2		1 - 3		1 - 4		1 - 6		1 - 12	
Contact layout (Orientation 0)											
TEMPERATURE	ORIENTATION	STYLE REF	NATO STOCK NO	STYLE REF	NATO STOCK NO	STYLE REF	NATO STOCK NO	STYLE REF	NATO STOCK NO	STYLE REF	NATO STOCK NO
T4 -55/+100°C	0	PO4B4C1-2/ /0	5935-99- 013-1374	PO4B4C1-3/ /0	5935-99- 013-1380	PO4B4C1-4/ /0	5935-99- 013-1382	PO4B4C1-6/ /0	5935-99- 013-1388	PO4B4C1-12/ /0	5935-99- 014-8853
	1	/1	013-1375	-	-	/1	013-1383	/1	013-1389	/1	014-8859
	2	/2	013-1376	-	-	/2	013-1384	/2	013-1390	/2	014-8860
	3	/3	013-1377	-	-	/3	013-1385	/3	013-1391	/3	014-8861
	4	/4	013-1378	-	-	/4	013-1386	/4	013-1392	/4	014-8862
	5	/5	013-1379	-	013-1381	/5	013-1387	/5	013-1393	/5	014-8863
Drawing number		CC/C/1136		CC/C/1137		CC/C/1138		CC/C/1139		CC/C/1375	
Max. weight (gramme)		86		85		85		85		86	
Current rating at max. temp (ampere/contact)	Cables: DEF STAN 61-12 (PART 5)	16		2.5		2.5		2.5		-	
	DEF STAN 61-12 (PART 4)	-		-		-		-		2	
	Open-wiring	19		5		5		5		3.5	
Max. working voltage (sea level)		500		500		500		500		500	

Notes applicable to this Table are on page 73.

DEF STAN 61-12 (Part 1)
 SECTION 7
 TABLE I(H)

TABLE I(H) - CONTINUED

DEF STAN 59-35 (PART 1)
SECTION 2/1
TABLE I(H)(CONTD)

SHELL SIZE - NO OF CONTACTS		2 - 2		2 - 4		2 - 6		2 - 12		2 - 26	
Contact layout (Orientation 0)											
TEMPERATURE	ORIENTATION	STYLE REF	NATO STOCK NO	STYLE REF	NATO STOCK NO	STYLE REF	NATO STOCK NO	STYLE REF	NATO STOCK NO	STYLE REF	NATO STOCK NO
T ₄ -55/+100°C	0	PO4D4C2-2/ /0	5935-99- 014-8864	PO4D4C2-4/ /0	5935-99- 013-1394	PO4D4C2-6/ /0	5935-99- 013-1400	PO4D4C2-12/ /0	5935-99- 013-1406	PO4D4C2-26/ /0	5935-99- 014-8870
	1	/1	014-8865	/1	013-1395	/1	013-1401	/1	013-1407	/1	014-8871
	2	/2	014-8866	/2	013-1396	/2	013-1402	/2	013-1408	/2	014-8872
	3	/3	014-8867	/3	013-1397	/3	013-1403	/3	013-1409	/3	014-8873
	4	/4	014-8868	/4	013-1398	/4	013-1404	/4	013-1410	/4	014-8874
	5	/5	014-8869	/5	013-1399	/5	013-1405	/5	013-1411	/5	014-8875
Drawing number		CC/C/1407		CC/C/1140		CC/C/1141		CC/C/1142		CC/C/1375	
Max. weight (gramme)		113		113		97		98		130	
Current rating at max. temp (ampere/contact)	Cables: DEF STAN 61-12 (PART 5)	-		16		2.5		2.5		-	
	DEF STAN 61-12 (PART 4)	-		-		-		-		2	
	Open-wiring	35		19		5		5		3.5	
d.c. working voltage (sea level)		500		500		1500		500		500	

Notes applicable to this Table are on page 73.

TABLE I(H) - CONTINUED

SHELL SIZE - NO OF CONTACTS		3 - 4		3 - 5		3 - 6		3 - 9	
Contact layout (Orientation 0)									
TEMPERATURE	ORIENTATION	STYLE REF	NATO STOCK NO	STYLE REF	NATO STOCK NO	STYLE REF	NATO STOCK NO	STYLE REF	NATO STOCK NO
T4 -55/+100°C	0	PO4.B4.C3-4/ /0	5935-99- 013-14.12	PO4.B4.C3-5/ /0	5935-99- 014-8876	PO4.B4.C3-6/ /0	5935-99- 013-14.18	PO4.B4.C3-9/ /0	5935-99- 013-14.24
	1	/1	013-14.13	/1	014-8877	/1	013-14.19	/1	013-14.25
	2	/2	013-14.14	/2	014-8878	/2	013-14.20	/2	013-14.26
	3	/3	013-14.15	/3	014-8879	/3	013-14.21	/3	013-14.27
	4	/4	013-14.16	/4	014-8880	/4	013-14.22	/4	013-14.28
	5	/5	013-14.17	/5	014-8881	/5	013-14.23	/5	013-14.29
Drawing number		CC/C/1143		CC/C/1144		CC/C/1196		CC/C/1145	
Max. weight (gramme)		165		165		160		160	
Current rating at max. temp (ampere/contact)	Cables: DEP STAN 61-12 (PART 5)	-		-		-		-	
	DEP STAN 61-12 (PART 4)	-		-		-		-	
	Open-wiring	A, B, and C - 60 D - 19		A and B - 60 C, D, and E - 19		19		19	
d.c. working voltage (sea level)		500		500		2500		500	

Notes applicable to this Table are on page 73.

-55-

FIG. TAN: 59-25 (PART 1)
SECTION: 7/1
TABLE I(H) (CONTD)

TABLE I(H) - CONTINUED

DEF STAN 50-15 (PART 1)
SECTION 2/1
TABLE I(H) (CONTD)

SHELL SIZE - NO OF CONTACTS		3 - 18		3 - 25		3 - 37		3 - 62	
Contact layout (Orientation 0)									
TEMPERATURE	ORIENTATION	STYLE REF	NATO STOCK NO	STYLE REF	NATO STOCK NO	STYLE REF	NATO STOCK NO	STYLE REF	NATO STOCK NO
T _a -55/+100°C	0	PO4B4C3-18/ /0	5935-99- 013-1430	PO4B4C3-25/ /0	5935-99- 013-1436	PO4B4C3-37/ /0	5935-99- 014-8882	PO4B4C3-62/ /0	5935-99- 014-8888
	1	/1	013-1431	/1	013-1437	/1	014-8883	/1	014-8889
	2	/2	013-1432	/2	013-1438	/2	014-8884	/2	014-8890
	3	/3	013-1433	/3	013-1439	/3	014-8885	/3	014-8891
	4	/4	013-1434	/4	013-1440	/4	014-8886	/4	014-8892
	5	/5	013-1435	/5	013-1441	/5	014-8887	/5	014-8893
Drawing number		CC/C/1146		CC/C/1147		CC/C/1375		CC/C/1375	
Max. weight (gramme)		182		163		171		179	
Current rating at max. temp (ampere/contact)	Cables: DEF STAN 61-12 (PART 5)	2.5		2.5		-		-	
	DEF STAN 61-12 (PART 4)	-		-		2		2	
	Open-wiring	5		5		3.5		3.5	
l.c. working voltage (sea level)		500/1500 See note on page 73		500		500		500	

Notes applicable to this Table are on page 73.

TABLE I(J)

STANDARD RANGE

SOCKETS, ELECTRICAL

BRASS, FIXED, FEMALE SHELL, COARSE THREAD

SHELL SIZE - NO OF CONTACTS		1 - 2		1 - 3		1 - 4		1 - 6		1 - 12	
Contact layout (Orientation 0)											
TEMPERATURE	ORIENTATION	STYLE REF	NATO STOCK NO	STYLE REF	NATO STOCK NO	STYLE REF	NATO STOCK NO	STYLE REF	NATO STOCK NO	STYLE REF	NATO STOCK NO
T _h -55/+100°C	0	SO4B4X1-2/ /0	5935-99- 013-1442	SO4B4X1-3/ /0	5935-99- 013-1448	SO4B4X1-4/ /0	5935-99- 013-1450	SO4B4X1-6/ /0	5935-99- 013-1456	SO4B4X1-12/ /0	5935-99- 014-8894
	1	/1	013-1443	-	-	/1	013-1451	/1	013-1457	/1	014-8895
	2	/2	013-1444	-	-	/2	013-1452	/2	013-1458	/2	014-8896
	3	/3	013-1445	-	-	/3	013-1453	/3	013-1459	/3	014-8897
	4	/4	013-1446	-	-	/4	013-1454	/4	013-1460	/4	014-8898
	5	/5	013-1447	-	013-1449	/5	013-1455	/5	013-1461	/5	014-8899
Drawing number		CC/C/1124		CC/C/1125		CC/C/1126		CC/C/1127		CC/C/1376	
Max. weight (gramme)		65		64		64		67		82	
Current rating at max. temp (ampere/contact)	Cables: DEF STAN 61-12 (PART 5)	16		2.5		2.5		2.5		-	
	DEF STAN 61-12 (PART 4)	-		-		-		-		2	
	Open-wiring	19		5		5		5		3.5	
Ins. working voltage (nom level)		500		500		500		500		500	

Note applicable to this Table are on page 15.

TABLE I(J) - CONTINUED

DEF STAN 61-12 (PART 1)
SECTION 2.1
TABLE I(J) (CONT'D)

SHELL SIZE - NO OF CONTACTS		2 - 2		2 - 4		2 - 6		2 - 12		2 - 26		
Contact layout (Orientation 0)												
TEMPERATURE	ORIENTATION	STYLE REF	NATO STOCK NO	STYLE REF	NATO STOCK NO	STYLE REF	NATO STOCK NO	STYLE REF	NATO STOCK NO	STYLE REF	NATO STOCK NO	
T ₄ -55/+100 °C	0	SO4BLX2-2/ /0	5935-99- 014-9326	SO4BLX2-4/ /0	5935-99- 013-1462	SO4BLX2-6/ /0	5935-99- 013-1468	SO4BLX2-12/ /0	5935-99- 013-1474	SO4BLX2-26/ /0	5935-99- 014-8900	
	1	/1	014-9327	/1	013-1463	/1	013-1469	/1	013-1475	/1	014-8901	
	2	/2	014-9328	/2	013-1464	/2	013-1470	/2	013-1476	/2	014-8902	
	3	/3	014-9329	/3	013-1465	/3	013-1471	/3	013-1477	/3	014-8903	
	4	/4	014-9330	013-1466	/4	013-1466	/4	013-1472	/4	013-1478	/4	014-8904
	5	/5	014-9331	013-1467	/5	013-1467	/5	013-1473	/5	013-1479	/5	014-8905
Drawing number		CC/C/1397		CC/C/1128		CC/C/1129		CC/C/1130		CC/C/1376		
Max. weight (grams)		91		92		90		95		125		
Current rating at max. temp (ampere/contact)	Cables: DEF STAN 61-12 (PART 5)	-		16		2.5		2.5		-		
	DEF STAN 61-12 (PART 4)	-		-		-		-		2		
	Open-wiring	35		19		5		5		3.5		
d.c. working voltage (sea level)		500		500		1500		500		500		

Notes applicable to this Table are on page 73.

TABLE I(J) - CONTINUED

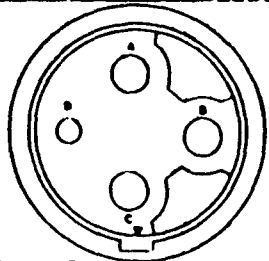
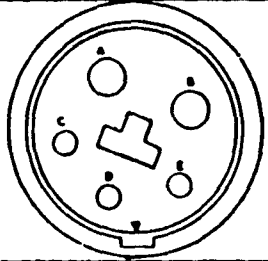
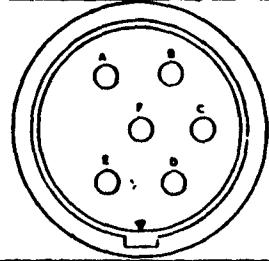
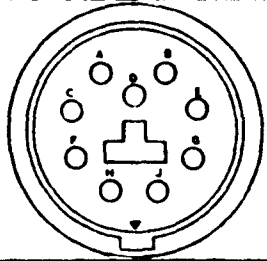
SHELL SIZE - NO OF CONTACTS		3 - 4		3 - 5		3 - 6		3 - 9	
Contact layout (Orientation 0)									
TEMPERATURE	ORIENTATION	STYLE REF	NATO STOCK NO	STYLE REF	NATO STOCK NO	STYLE REF	NATO STOCK NO	STYLE REF	NATO STOCK NO
T ₄ -55/+100 °C	0	S04BLX3-4/ /0	5935-99- 013-1481	S04BLX3-5/ /0	5935-99- 014-8906	S04BLX3-6/ /0	5935-99- 013-1486	S04BLX3-9/ /0	5935-99- 013-1492
	1	/1	013-1481	/1	014-8907	/1	013-1487	/1	013-1493
	2	/2	013-1482	/2	014-8908	/2	013-1488	/2	013-1494
	3	/3	013-1483	/3	014-8909	/3	013-1489	/3	013-1495
	4	/4	013-1484	/4	014-8910	/4	013-1490	/4	013-1496
5	/5	013-1485	/5	014-8911	/5	013-1491	/5	013-1497	
Drawing number		CC/C/1131		CC/C/1132		CC/C/1195		CC/C/1133	
Max. weight (gramme)		166		166		155		164	
Current rating at max. temp (ampere/contact)	Cables: DEF STAN 61-12 (PART 5)	-		-		-		-	
	DEF STAN 61-12 (PART 4)	-		-		-		-	
	Open-wiring	A, B, and C - 60 D - 19		A and B - 60 C, D, and E - 19		19		19	
Low working voltage (sea level)		500		500		2500		500	

Notes applicable to this Table are on page 13.

TABLE I(J) - CONTINUED

DEF STAN 61-16 (APP 1)
 SECTION 7/1
 TABLE I(J) (CONT'D)

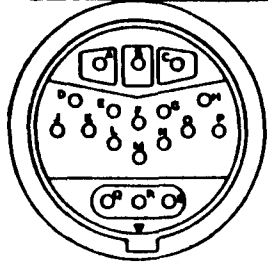
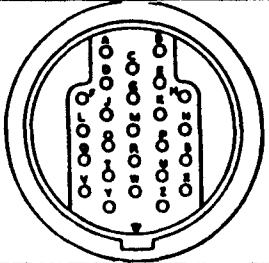
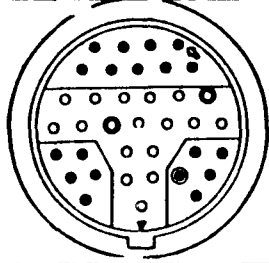
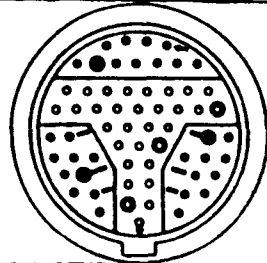
SHELL SIZE - NO OF CONTACTS		3 - 18		3 - 25		3 - 37		3 - 62	
Contact layout (Orientation 0)									
TEMPERATURE	ORIENTATION	STYLE REF	NATO STOCK NO.	STYLE REF	NATO STOCK NO.	STYLE REF	NATO STOCK NO.	STYLE REF	NATO STOCK NO.
T ₄ -55/+100 °C	0	S04B4X3-18/ /0	5935-99- 013-1498	S04B4X3-25/ /0	5935-99- 013-1504	S04B4X3-37/ /0	5935-99- 014-8912	S04B4X3-62/ /0	5935-99- 014-8918
	1	/1	013-1499	/1	013-1505	/1	014-8913	/1	014-8919
	2	/2	013-1500	/2	013-1506	/2	014-8914	/2	014-8920
	3	/3	013-1501	/3	013-1507	/3	014-8915	/3	014-8921
	4	/4	013-1502	/4	013-1508	/4	014-8916	/4	014-8922
	5	/5	013-1503	/5	013-1509	/5	014-8917	/5	014-8923
Drawing number		CC/C/1134		CC/C/1135		CC/C/1376		CC/C/1376	
Max. weight (gramme)		159		159		169		175	
Current rating at max. temp (ampere/contact)	Cables: DEF STAN 61-12 (PART 5)	2.5		2.5		-		-	
	DEF STAN 61-12 (PART 4)	-		-		2		2	
	Open-wiring	5		5		3.5		3.5	
d.c. working voltage (sea level)		500/1500 See note on page 73		500		500		500	

Notes applicable to this Table are on page 73.

TABLE I(K)

STANDARD RANGE

SOCKETS, ELECTRICAL

BRASS, FREE, MALE SHELL, COARSE THREAD



SHELL SIZE - NO OF CONTACTS		1 - 2		1 - 3		1 - 4		1 - 6		1 - 12	
Contact layout (Orientation 0)											
TEMPERATURE	ORIENTATION	STYLE REF	NATO STOCK NO	STYLE REF	NATO STOCK NO	STYLE REF	NATO STOCK NO	STYLE REF	NATO STOCK NO	STYLE REF	NATO STOCK NO
TL -55/+100°C	0	S04BLP1-2/ /0	5935-99- 013-1510	S04BLP1-3/ /0	5935-99- 013-1516	S04BLP1-4/ /0	5935-99- 013-1518	S04BLP1-6/ /0	5935-99- 013-1524	S04BLP1-12/ /0	5935-99- 014-8924
	1	/1	013-1511	-	-	/1	013-1519	/1	013-1525	/1	014-8925
	2	/2	013-1512	-	-	/2	013-1520	/2	013-1526	/2	014-8926
	3	/3	013-1513	-	-	/3	013-1521	/3	013-1527	/3	014-8927
	4	/4	013-1514	-	-	/4	013-1522	/4	013-1528	/4	014-8928
	5	/5	013-1515	013-1517	/5	013-1523	/5	013-1529	/5	014-8929	
Drawing number		CC/C/1112		CC/C/1113		CC/C/1114		CC/C/1115		CC/C/1374	
Max. weight (grams)		78		72		73		79		76	
Current rating at max. temp (amps/contact)	Cables: DEF STAN 61-12 (PART 5)	16		2.5		2.5		2.5		-	
	DEF STAN 61-12 (PART 5)	-		-		-		-		2	
	Open-wiring	19		5		5		5		3.5	
d.c. working voltage (nom level)		500		500		500		500		500	

Notes applicable to this Table are on page 75.

FIG. 44
 SECTION 22
 TABLE I(K)

TABLE I(K) - CONTINUED

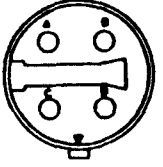
DEF STAN 59-35 (PART 1)
SECTION 2/1
TABLE I(K) (CONTD)

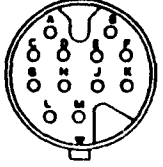
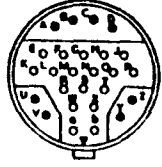
SHELL SIZE - NO OF CONTACTS		2 - 2		2 - 4		2 - 6		2 - 12		2 - 26	
Contact layout (Orientation 0)											
TEMPERATURE	ORIENTATION	STYLE REF	NATO STOCK NO	STYLE REF	NATO STOCK NO	STYLE REF	NATO STOCK NO	STYLE REF	NATO STOCK NO	STYLE REF	NATO STOCK NO
T _h -55/+100 °C	0	SO4B4P2-2/ /0	5935-99- 014-8930	SO4B4P2-4/ /0	5935-99- 013-1530	SO4B4P2-6/ /0	5935-99- 013-1536	SO4B4P2-12/ /0	5935-99- 013-1542	SO4B4P2-26/ /0	5935-99- 014-8936
	1	/1	014-8931	/1	013-1531	/1	013-1537	/1	013-1543	/1	014-8937
	2	/2	014-8932	/2	013-1532	/2	013-1538	/2	013-1544	/2	014-8938
	3	/3	014-8933	/3	013-1533	/3	013-1539	/3	013-1545	/3	014-8939
	4	/4	014-8934	/4	013-1534	/4	013-1540	/4	013-1546	/4	014-8940
	5	/5	014-8935	/5	013-1535	/5	013-1541	/5	013-1547	/5	014-8941
Drawing number		CC/C/1402		CC/C/1116		CC/C/1117		CC/C/1118		CC/C/1374	
Max. weight (grams)		103		106		102		103		124	
Current rating at max. temp (ampere/contact)	Cables: DEF STAN 61-12 (PART 5)	-		16		2.5		2.5		-	
	DEF STAN 61-12 (PART 4)	-		-		-		-		2	
	Open-wiring	35		19		5		5		3.5	
i.c. working voltage (sea level)		500		500		1500		500		500	

Notes applicable to this Table are on page 73.

TABLE I(K) - CONTINUED

SHELL SIZE - NO OF CONTACTS		3 - 4		3 - 5		3 - 6		3 - 9	
Contact layout (Orientation 0)									
TEMPERATURE	ORIENTATION	STYLE REF	NATO STOCK NO	STYLE REF	NATO STOCK NO	STYLE REF	NATO STOCK NO	STYLE REF	NATO STOCK NO
T4 -55/+100°C	0	S04B4P3-4/ /0	5935-99- 013-1548	S04B4P3-5/ /0	5935-99- 014-8942	S04B4P3-6/ /0	5935-99- 013-1554	S04B4P3-9/ /0	5935-99- 013-1560
	1	/1	013-1549	/1	014-8943	/1	013-1555	/1	013-1561
	2	/2	013-1550	/2	014-8944	/2	013-1556	/2	013-1562
	3	/3	013-1551	/3	014-8945	/3	013-1557	/3	013-1563
	4	/4	013-1552	/4	014-8946	/4	013-1558	/4	013-1564
	5	/5	013-1553	/5	014-8947	/5	013-1559	/5	013-1565
Drawing number		CC/C/1119		CC/C/1120		CC/C/1194		CC/C/1121	
Max weight (grams)		182		182		183		183	
Current rating at max. temp (ampere/contact)	Cables: DEF STAN 61-12 (PART 5)	-		-		-		-	
	DEF STAN 61-12 (PART 4)	-		-		-		-	
	Open-wiring	A, B, and C - 60 D - 19		A and B - 60 C, D, and E - 19		19		19	
d.c. working voltage (sea level)		500		500		500		500	

Notes applicable to this Table are on page 75.

-63-

DEF STAN 59-35 (PART 1)
SECTION 2/1

TABLE I(K) - CONTINUED

DEF STAN 99-35 (PART 1)
SECTION 2/1
TABLE I(K) (CONTD)

SHELL SIZE - NO OF CONTACTS		3 - 18		3 - 25		3 - 37		3 - 62	
Contact layout (Orientation 0)									
TEMPERATURE	ORIENTATION	STYLE REF	NATO STOCK NO	STYLE REF	NATO STOCK NO	STYLE REF	NATO STOCK NO	STYLE REF	NATO STOCK NO
T4 -55/+100°C	0	S04B4F3-18/ /0	5935-99- 013-1566	S04B4F3-25/ /0	5935-99- 013-1572	S04B4F3-37/ /0	5935-99- 014-8948	S04B4F3-62/ /0	5935-99- 014-8954
	1	/1	013-1567	/1	013-1573	/1	014-8949	/1	014-8955
	2	/2	013-1568	/2	013-1574	/2	014-8950	/2	014-8956
	3	/3	013-1569	/3	013-1575	/3	014-8951	/3	014-8957
	4	/4	013-1570	/4	013-1576	/4	014-8952	/4	014-8958
	5	/5	013-1571	/5	013-1577	/5	014-8953	/5	014-8959
Drawing number		CC/C/1122		CC/C/1123		CC/C/1374		CC/C/1374	
Max. weight (gramme)		177		182		170		178	
Current rating at max. temp (ampere/contact)	Cables: DEF STAN 61-12 (PART 5)	2.5		2.5		-		-	
	DEF STAN 61-12 (PART 4)	-		-		2		2	
	Open-wiring	5		5		3.5		3.5	
d.c. working voltage (sea level)		500/1500 See note page 73		500		500		500	

Notes applicable to this Table are on page 73.

TABLE I(L)

STANDARD RANGE

PLUGS, ELECTRICAL, ALUMINIUM, FIXED FEMALE SHELL, COARSE THREAD

SHELL SIZE - NO OF CONTACTS		1 - 2		1 - 3		1 - 4		1 - 6		1 - 12	
Contact layout (Orientation 0)											
TEMPERATURE	ORIENTATION	STYLE REF	NATO STOCK NO	STYLE REF	NATO STOCK NO	STYLE REF	NATO STOCK NO	STYLE REF	NATO STOCK NO	STYLE REF	NATO STOCK NO
74 -55, +100°K	0	P04C4X1-2/ /0	5935-99- 014-8960	P04C4X1-3/ /0	5935-99- 014-8966	P04C4X1-4/ /0	5935-99- 014-8972	P04C4X1-6/ /0	5935-99- 014-8978	P04C4X1-12/ /0	5935-99- 014-8984
	1	/1	014-8961	-	-	/1	014-8973	/1	014-8979	/1	014-8985
	2	/2	014-8962	-	-	/2	014-8974	/2	014-8980	/2	014-8986
	3	/3	014-8963	-	-	/3	014-8975	/3	014-8981	/3	014-8987
	4	/4	014-8964	-	-	/4	014-8976	/4	014-8982	/4	014-8988
	5	/5	014-8965	-	014-8971	/5	014-8977	/5	014-8983	/5	014-8989
Drawing number		CC1356		CC 1357		CC1358		CC1359		/ / 1370	
Max. weight (gramme)		30		30		30		30		30	
Current rating at max. temp (ampere/contact)	Cables: DEF STAN 61-12 (PART 5)	16		2.5		2.5		2.5		-	
	DEF STAN 61-12 (PART 4)	-		-		-		-		2	
	Open-wiring	19		5		5		5		3.5	
Working voltage (sea level)		500		500		500		500		500	

1. The applicable to this table are on page 75.

1. The applicable to this table are on page 75.

TABLE I(L) - CONTINUED

DEF STAN 59-15 (PART 1)
SECTION 3
TABLE I(D) (CONT'D)

SHELL SIZE - NO OF CONTACTS		2 - 2		2 - 4		2 - 6		2 - 12		2 - 26	
Contact layout (Orientation 0)											
TEMPERATURE	ORIENTATION	STYLE REF	NATO STOCK NO	STYLE REF	NATO STOCK NO	STYLE REF	NATO STOCK NO	STYLE REF	NATO STOCK NO	STYLE REF	NATO STOCK NO
T ₄ -55/+100°C	0	PO4CLX2-2/ /0	5935-99- 014-8990	PO4CLX2-4/ /0	5935-99- 014-8996	PO4CLX2-6/ /0	5935-99- 014-9002	PO4CLX2-12/ /0	5935-99- 014-9008	PO4CLX2-26/ /0	5935-99- 014-9014
	1	/1	014-8991	/1	014-8997	/1	014-9003	/1	014-9009	/1	014-9015
	2	/2	014-8992	/2	014-8998	/2	014-9004	/2	014-9010	/2	014-9016
	3	/3	014-8993	/3	014-8999	/3	014-9005	/3	014-9011	/3	014-9017
	4	/4	014-8994	/4	014-9000	/4	014-9006	/4	014-9012	/4	014-9018
	5	/5	014-8995	/5	014-9001	/5	014-9007	/5	014-9013	/5	014-9019
Drawing number		CC1360		CC1361		CC1362		CC1363		CC/C/1370	
Max. weight (gramme)		36		38		40		45		45	
Current rating at max. temp (ampere/contact)	Cables: DEF STAN 61-12 (PART 5)	-		16		2.5		2.5		-	
	DEF STAN 61-12 (PART 4)	-		-		-		-		2	
	Open-wiring	35		19		5		5		3.5	
d.c. working voltage (sea level)		500		500		1500		500		500	

Notes applicable to this Table are on page 73.

TABLE I(L) - CONTINUED

SHELL SIZE - NO OF CONTACTS		3 - 4		3 - 5		3 - 6		3 - 9	
Contact layout (Orientation 0)									
TEMPERATURE	ORIENTATION	STYLE REF	NATO STOCK NO	STYLE REF	NATO STOCK NO	STYLE REF	NATO STOCK NO	STYLE REF	NATO STOCK NO
T ₄ -55/+100°C	0	PO4CLX3-4/ /0	5935-99- 014-9020	PO4CLX3-5/ /0	5935-99- 014-9026	PO4CLX3-6/ /0	5935-99- 014-9032	PO4CLX3-9/ /0	5935-99- 014-9038
	1	/1	014-9021	/1	014-9027	/1	014-9033	/1	014-9039
	2	/2	014-9022	/2	014-9028	/2	014-9034	/2	014-9040
	3	/3	014-9023	/3	014-9029	/3	014-9035	/3	014-9041
	4	/4	014-9024	/4	014-9030	/4	014-9036	/4	014-9042
	5	/5	014-9025	/5	014-9031	/5	014-9037	/5	014-9043
Drawing number		CC1364		CC1365		CC1366		CC1367	
Max. weight (gramme)		65		67		69		73	
Current rating at max. temp (ampere/contact)	Cables: DEF STAN 61-12 (PART 5)	-		-		-		-	
	DEF STAN 61-12 (PART 4)	-		-		-		-	
	Open-wiring	A, B, and C - 60 D - 19		A and B - 60 C, D, and E - 19		19		19	
Max. working voltage (amp level)		500		500		500		500	

Notes applicable to this Table are on page 75.

DEF STAN 61-12
SECTION 61-12
TABLE I(L) (CONT)

-67-

TABLE I(L) - CONTINUED

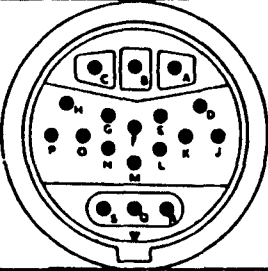
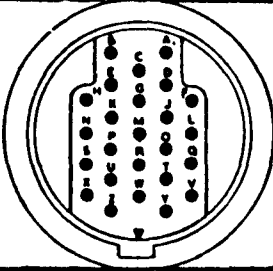
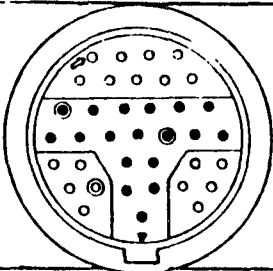
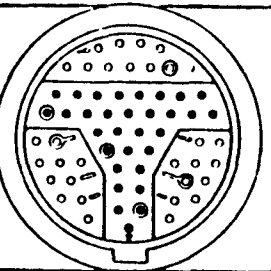
SHELL SIZE - NO OF CONTACTS		3 - 18		3 - 25		3 - 37		3 - 62	
Contact layout (Orientation 0)									
TEMPERATURE	ORIENTATION	STYLE REF	NATO STOCK NO	STYLE REF	NATO STOCK NO	STYLE REF	NATO STOCK NO	STYLE REF	NATO STOCK NO
T _l -55/+100°C	0	POLCLX3-18/ /0	5935-99- 014-9044	POLCLX3-25/ /0	5935-99- 014-9050	POLCLX3-37/ /0	5935-99- 014-9056	POLCLX3-62/ /0	5935-99- 014-9062
	1	/1	014-9045	/1	014-9051	/1	014-9057	/1	014-9063
	2	/2	014-9046	/2	014-9052	/2	014-9058	/2	014-9064
	3	/3	014-9047	/3	014-9053	/3	014-9059	/3	014-9065
	4	/4	014-9048	/4	014-9054	/4	014-9060	/4	014-9066
	5	/5	014-9049	/5	014-9055	/5	014-9061	/5	014-9067
Drawing number		CC1368		CC1369		CC/C/1370		CC/C/1370	
Max. weight (gramme)		77		80		80		84	
Current rating at max. temp (ampere/contact)	Cables: DEF STAN 61-12 (PART 5)	2.5		-		-		-	
	DEF STAN 61-12 (PART 4)	-		-		2		2	
	Open-wiring	5		5		3.5		3.5	
d.c. working voltage (sea level)		500/1500 See note on page 73		500		500		500	

Notes applicable to this Table are on page 73.

DEF STAN 61-12 (PART 4)
SECTION 2/1
TABLE I(L) (CONT.)

TABLE 1(b)

STANDARD RANGE

SOCKETS, ELECTRICAL, ALUMINIUM, FIXED FEMALE SHELL, COARSE THREAD

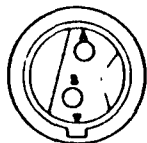
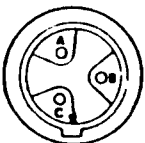
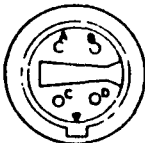
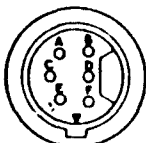
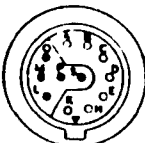
SHELL SIZE - NO OF CONTACTS		1 - 2		1 - 3		1 - 4		1 - 6		1 - 12	
Contact layout (Orientation 0)											
TEMPERATURE	ORIENTATION	STYLE REF	NATO STOCK NO	STYLE REF	NATO STOCK NO	STYLE REF	NATO STOCK NO	STYLE REF	NATO STOCK NO	STYLE REF	NATO STOCK NO
T4 -55/+100°C	0	SO4CLX1-2/ /0	5935-99- 014-9068	SO4CLX1-3/ /0	5935-99- 014-9074	SO4CLX1-4/ /0	5935-99- 014-9080	SO4CLX1-6/ /0	5935-99- 014-9086	SO4CLX1-12/ /0	5935-99- 014-9092
	1	/1	014-9069	-	-	/1	014-9081	/1	014-9087	/1	014-9093
	2	/2	014-9070	-	-	/2	014-9082	/2	014-9088	/2	014-9094
	3	/3	014-9071	-	-	/3	014-9083	/3	014-9089	/3	014-9095
	4	/4	014-9072	-	-	/4	014-9084	/4	014-9090	/4	014-9096
	5	/5	014-9073	-	014-9079	/5	014-9085	/5	014-9091	/5	014-9097
Drawing number		CC1356		CC1357		CC1358		CC1359		CC/C/1370	
Max. weight (gramme)		30		30		30		30		30	
Cables: DEF STAN 61-12 (PART 5) DEF STAN 61-12 (PART 4) Open-wiring	16		2.5		2.5		2.5		-		
	-		-		-		-		2		
	19		5		5		5		3.5		
500		500		500		500		500		500	

Refer to this Table also on page 25.

TABLE 1(b)

TABLE I(M) - CONTINUED

DEF STAN 61-12 (PART 1)
SECTION 71
TABLE I(M)

SHELL SIZE - NO OF CONTACTS		2 - 2		2 - 4		2 - 6		2 - 12		2 - 26	
Contact layout (Orientation 0)											
TEMPERATURE	ORIENTATION	STYLE REF	NATO STOCK NO	STYLE REF	NATO STOCK NO	STYLE REF	NATO STOCK NO	STYLE REF	NATO STOCK NO	STYLE REF	NATO STOCK NO
T ₄ -55/+100°C	0	S04C4X2-2/ /0	5935-99- 014-9098	S04C4X2-4/ /0	5935-99- 014-9104	S04C4X2-6/ /0	5935-99- 014-9110	S04C4X2-12/ /0	5935-99- 014-9116	S04C4X2-26/ /0	5935-99- 014-9122
	1	/1	014-9099	/1	014-9105	/1	014-9111	/1	014-9117	/1	014-9123
	2	/2	014-9100	/2	014-9106	/2	014-9112	/2	014-9118	/2	014-9124
	3	/3	014-9101	/3	014-9107	/3	014-9113	/3	014-9119	/3	014-9125
	4	/4	014-9102	/4	014-9108	/4	014-9114	/4	014-9120	/4	014-9126
	5	/5	014-9103	/5	014-9109	/5	014-9115	/5	014-9121	/5	014-9127
Drawing number		CC1360		CC1361		CC1362		CC1363		CC/C/1370	
Max. weight (gramme)		36		38		40		45		45	
Current rating at max. temp (ampere/contact)	Cables: DEF STAN 61-12 (PART 5)	-		16		2.5		2.5		-	
	DEF STAN 61-12 (PART 4)	-		-		-		-		2	
	Open-wiring	35		19		5		5		3.5	
I. _{sc} working voltage (sea level)		500		500		1500		500		500	

Notes applicable to this Table are on page 73.

TABLE I(M) - CONTINUED

SHELL SIZE - NO OF CONTACTS		3 - 4		3 - 5		3 - 6		3 - 9	
Contact layout (Orientation 0)									
TEMPERATURE	ORIENTATION	STYLE REF	NATO STOCK NO	STYLE REF	NATO STOCK NO	STYLE REF	NATO STOCK NO	STYLE REF	NATO STOCK NO
T ₄ -55/+100°C	0	SO4C4X3-4/ /0	5935-99- 014-9128	SO4C4X3-5/ /0	5935-99- 014-9134	SO4C4X3-6/ /0	5935-99- 014-9140	SO4C4X3-9/ /0	5935-99- 014-9146
	1	/1	014-9129	/1	014-9135	/1	014-9141	/1	014-9147
	2	/2	014-9130	/2	014-9136	/2	014-9142	/2	014-9148
	3	/3	014-9131	/3	014-9137	/3	014-9143	/3	014-9149
	4	/4	014-9132	/4	014-9138	/4	014-9144	/4	014-9150
	5	/5	014-9133	/5	014-9139	/5	014-9145	/5	014-9151
Drawing number		CC/C/1369		CC/C/1369		CC/C/1369		CC/C/1369	
Max. weight (gramme)		65		67		69		73	
Current rating at max. temp (ampere/contact)	Cables: DEF STAN 61-12 (PART 5)	-		-		-		-	
	DEF STAN 61-12 (PART 4)	-		-		-		-	
	Open-wiring	A, B, and C - 60 D - 19		A and B - 60 C, D, and E - 19		19		19	
d.c. working voltage (sea level)		500		500		2500		500	

Notes applicable to this Table are on page 73.

TABLE I(M) - CONTINUED

DEF STAN 61-12 (PART 1)
 SECTION 71
 TABLE I(M) (CONT.)

SHELL SIZE - NO OF CONTACTS		3 - 18		3 - 25		3 - 37		3 - 62	
Contact layout (Orientation 0)									
TEMPERATURE	ORIENTATION	STYLE REF	NATO STOCK NO	STYLE REF	NATO STOCK NO	STYLE REF	NATO STOCK NO	STYLE REF	NATO STOCK NO
T ₄ -55/+100°C	0	SO4CX3-18/ /0	5935-99- 014-9152	SO4CX3-25/ /0	5935-99- 014-9158	SO4CX3-37/ /0	5935-99- 014-9164	SO4CX3-62/ /0	5935-99- 014-9170
	1	/1	014-9153	/1	014-9159	/1	014-9165	/1	014-9171
	2	/2	014-9154	/2	014-9160	/2	014-9166	/2	014-9172
	3	/3	014-9155	/3	014-9161	/3	014-9167	/3	014-9173
	4	/4	014-9156	/4	014-9162	/4	014-9168	/4	014-9174
	5	/5	014-9157	/5	014-9163	/5	014-9169	/5	014-9175
Drawing number		CC1368		C-1369		CC/C/1370		CC/C/1370	
Max. weight (gramme)		77		80		80		84	
Current rating at max. temp (ampere/contact)	Cables: DEF STAN 61-12 (PART 5)	2.5		2.5		-		-	
	DEF STAN 61-12 (PART 4)	-		-		2		2	
	Open-wiring	5		5		3.5		3.5	
d.c. working voltage (sea level)		500/1500 See note page 73		500		500		500	

-72-

tes applicable to this Table are on page 73.

NOTES APPLICABLE TO TABLES

1. The Navy management code is the last seven digits of the NATO Stock Number prefixed by 0568, eg 0568/000-0000.
2. The Army management code is the NATO Stock Number prefixed by Z32, eg Z32/5935-99-COC-0000.
3. The Air Force management code is the last seven digits of the NATO Stock Number prefixed by 10H, eg 10H/0000000 (the number is not hyphenated).
4. - indicates that the column heading does not apply.
5. The Shell Size 3, 18 contact items have d.c. voltages of:
 - Contacts ADC 1500 V to any other contacts or to the shell.
 - Contacts D to P 500 V to any other of these contacts or to the shell.
 - Contacts QRS 500 V between these contacts.
 - Contacts QRS 1500 V to any other contacts or to the shell.
6. Items with male and female contacts are correctly titled 'Plug-socket, electrical' but, for convenience, they are grouped under the general titles 'Plug, electrical or socket, electrical' in Tables I(A) - I(M).

NOTES APPLICABLE TO

PERMISSIBLE ORIENTATIONS SHELL SIZES 1, 2 AND 3

1. The diagrams are of mating the faces and show the standard orientations of the insert in relation to the Shell. The single key/key way of the shell is represented by the black square at the base of each diagram.
2. Refer to Tables I(A) - I(M) for enlarged view of panform.
3. The contact location plan of High Density Styles is as follows:
 - a. The arrow indicates the starting point.
 - b. Every subsequent tenth contact is ringed.
 - c. The rectangular markers indicate the direction to be followed when sequential contacts are not in line.
4. In other styles each contact is indexed.
5. Orientations and contact allocations reserved for power supplies are listed in DEF STAN 59-4 (PART 7).

OVERALL ASSEMBLED LENGTHS

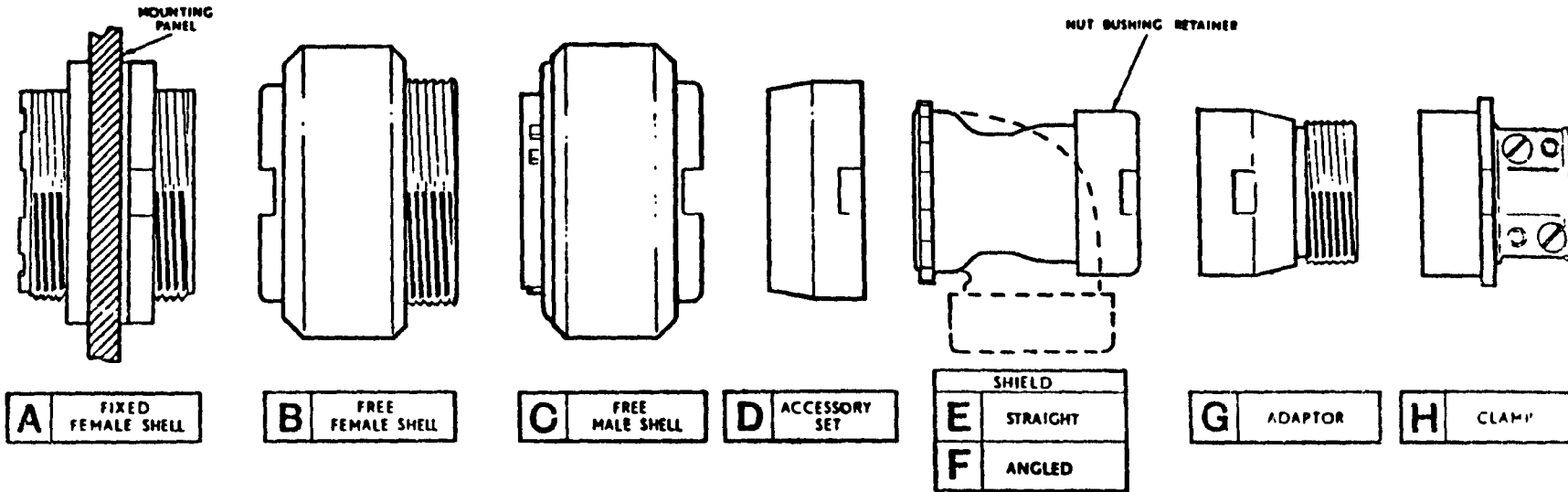

NOTES : 1. THE DIMENSIONS QUOTED ARE FOR THE LARGEST SHIELD IN ANY INDIVIDUAL SHELL SIZE
2. ADDITIONAL DIMENSIONAL DATA MAY BE FOUND ON PAGES 75, 76, 77

		ALUMINIUM FINE THREAD						ALUMINIUM COARSE THREAD						BRASS COARSE THREAD					
		1		2		3		1		2		3		1		2		3	
		m/m	inch	m/m	inch	m/m	inch	m/m	inch	m/m	inch	m/m	inch	m/m	inch	m/m	inch	m/m	inch
MATED SHELLS																			
A AND C		46.2	1.82	46.2	1.82	49.5	1.95	45.2	1.78	47.2	1.86	46.7	1.84	46.2	1.82	46.2	1.82	49.5	1.95
B AND C		49.8	1.96	49.8	1.96	53.3	2.10	NOT APPLICABLE						47.0	1.85	47.0	1.85	53.3	2.10
CABLE FITTINGS		ADD DIMENSIONS QUOTED BELOW TO THOSE SHOWN ABOVE TO CALCULATE OVERALL ASSEMBLED LENGTHS OF SHELLS AND CABLE FITTINGS																	
D ONLY	HIGH DENSITY STYLES	8.4	.33	8.6	.34	8.9	.35	8.4	.33	8.6	.34	8.9	.35	8.4	.33	8.6	.34	8.9	.35
D AND E	-	36.1	1.42	61.7	2.43	66.5	2.62	36.1	1.42	61.7	2.43	66.5	2.62	36.1	1.42	61.7	2.43	66.5	2.62
E ONLY	INCLUDING NUT, BUSHING RETAINER	27.7	1.09	53.1	2.09	57.7	2.27	27.7	1.09	53.1	2.09	57.7	2.27	27.7	1.09	53.1	2.09	57.7	2.27
D AND F	"	26.2	1.03	45.2	1.78	57.7	2.27	26.2	1.03	45.2	1.78	57.7	2.27	26.2	1.03	45.2	1.78	57.7	2.27
F ONLY	"	17.8	.70	36.6	1.44	48.8	1.92	17.8	.70	36.6	1.44	48.8	1.92	17.8	.70	36.6	1.44	48.8	1.92
E AND G	"	NOT PROVISIONED		28.2	1.11	30.0	1.18	NOT PROVISIONED		28.2	1.11	30.0	1.18	NOT PROVISIONED		28.2	1.11	30.0	1.18
F AND G	"	NOT PROVISIONED		36.6	1.44	48.8	1.92	NOT PROVISIONED		36.6	1.44	48.8	1.92	NOT PROVISIONED		36.6	1.44	48.8	1.92
E AND H	NUT BUSHING RETAINER DISCARDED	39.9	1.57	65.3	2.57	73.2	2.88	39.9	1.57	65.3	2.57	73.2	2.88	39.9	1.57	65.3	2.57	73.2	2.88
F AND H	"	22.9	.90	41.7	1.64	53.9	2.12	22.9	.90	41.7	1.64	53.9	2.12	22.9	.90	41.7	1.64	53.9	2.12
G AND H	"	NOT PROVISIONED		51.3	2.02	57.7	2.27	NOT PROVISIONED		51.3	2.02	57.7	2.27	NOT PROVISIONED		51.3	2.02	57.7	2.27

FIGURE 5
-74-

PLUGS AND SOCKETS, ELECTRICAL, PATTERN 104
CIRCULAR, SEALED ALUMINIUM SHELLS WITH THREADED COUPLING

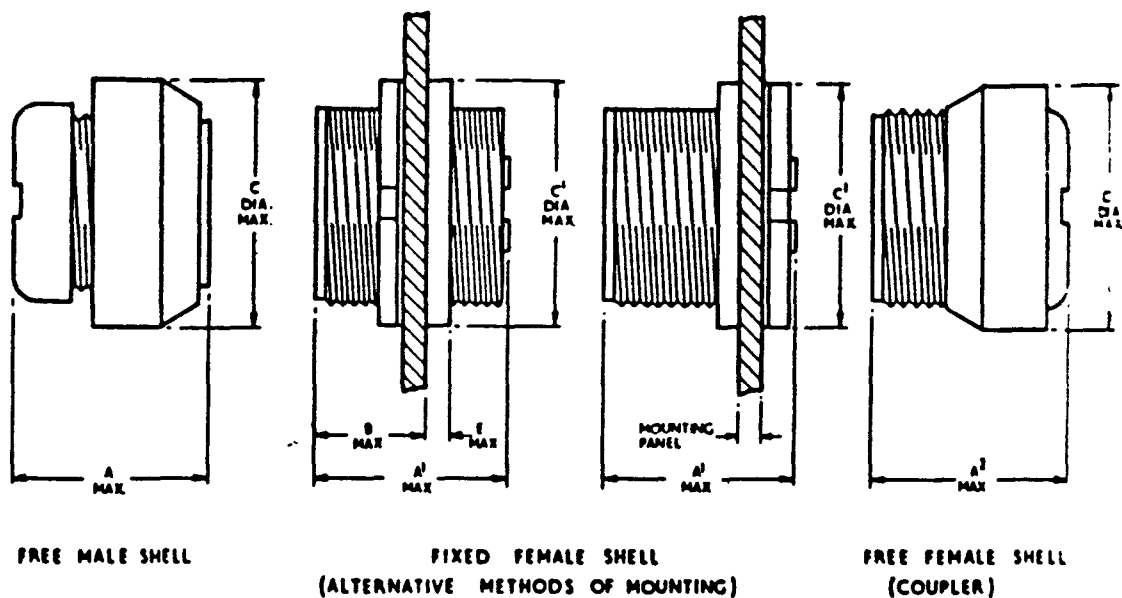

DIMENSIONS

SIZE	A		A'		A''		B		C		C'		E	Ø
	M/M	INS	M/M	INS	M/M	INS	M/M	INS	M/M	INS	M/M	INS		
1	26.67	1.05	26.67	1.05	30.48	1.20	13.97	0.55	29.21	1.15	27.70	1.13	2.30	Ø-13
2	26.67	1.05	26.67	1.05	30.48	1.20	13.97	0.55	34.79	1.37	34.29	1.35	2.30	Ø-13
3	30.48	1.20	29.21	1.15	33.02	1.30	13.24	0.60	44.45	1.73	43.94	1.73	3.81	Ø-15

SIZE 1

SIZE 2

SIZE 3

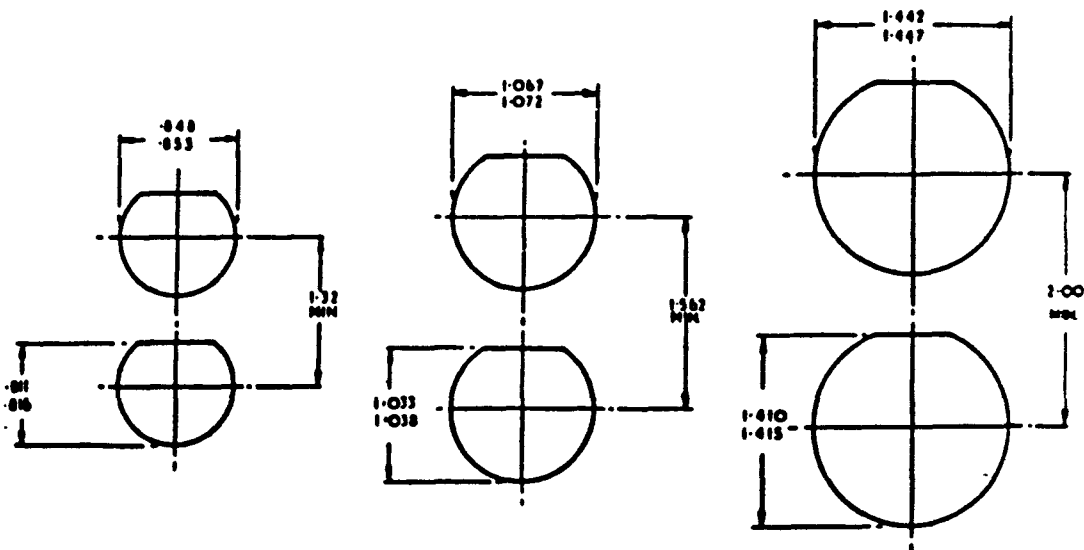

PANEL PIERCING
(MAXIMUM PANEL THICKNESS 0.3)

TOLERANCES: AS STATED

NOTES:

MARKING. THE NATO STOCK No. MANUFACTURERS CODE AND DATE CODE (SEE DEF-5004-0 TO BE LEGIBLY AND INDELIBLY MARKED ON COMPONENT AS INSTRUCTED ON CONTROL DRG.

1 EL PIERCING. THE DIMENSIONS BETWEEN CENTRES ARE RECOMMENDED MINIMUM SPACING BETWEEN ADJACENT ITEMS.

PLUGS AND SOCKETS, ELECTRICAL, PATTERN 104
CIRCULAR, SEALED ALUMINIUM SHELLS WITH COARSE THREADED COUPLING

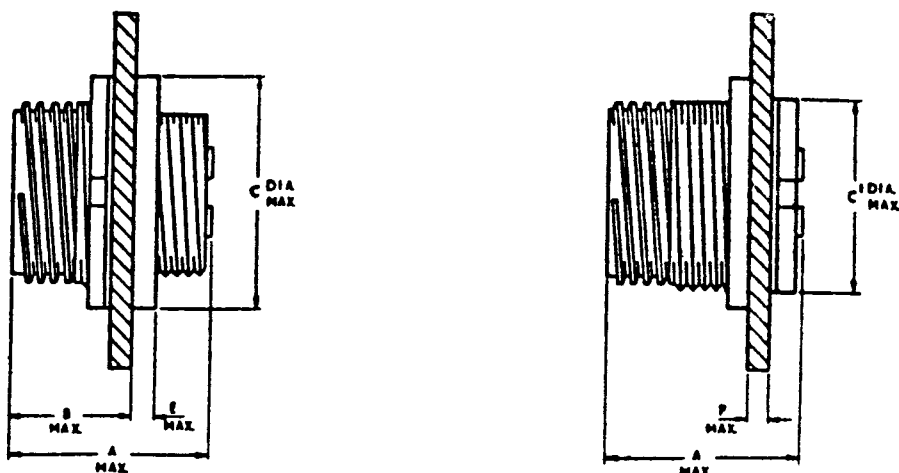

FIXED FEMALE SHELL
(ALTERNATIVE METHODS OF MOUNTING)

METRIC DIMENSIONS DERIVED FROM ORIGINAL INCH DIMENSIONS

SIZE	A MAX.		B MAX.		C MAX.		C' MAX.		E MAX.		P MAX.	
	M/M	INS	M/M	INS	M/M	INS	M/M	INS	M/M	INS	M/M	INS
1	27.69	1.090	17.27	.680	34.29	1.350	21.59	.850	3.91	.154	3.30	.130
2					43.94	1.730	27.18	1.070				
3	28.93	1.139			48.90	1.923	43.94	1.730	4.37	.180		

PANEL PIERCING

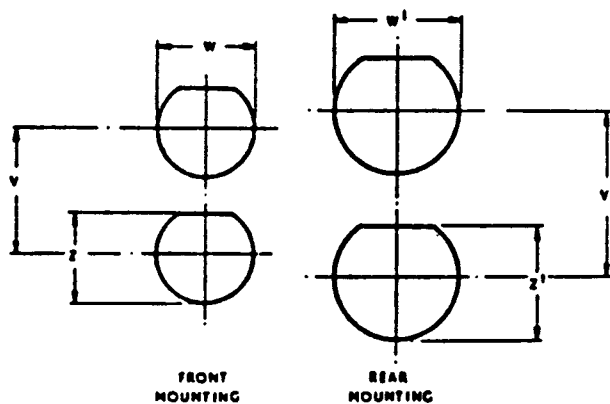

SIZE	V		V'		W		W'		Z		Z'	
	M/M	INS	M/M	INS	M/M	INS	M/M	INS	M/M	INS	M/M	INS
1	33.53	1.32	39.68	1.562	21.33	.848	27.10	1.067	20.60	.811	26.23	1.033
					21.66	.853	27.23	1.072	20.73	.816	26.36	1.038
2	39.68	1.562	50.80	2.00	27.10	1.067	36.62	1.442	26.23	1.033	35.81	1.410
					27.23	1.072	36.75	1.447	26.36	1.038	35.94	1.415
3	50.80	2.00	56.93	2.23	36.62	1.442	42.42	1.670	35.81	1.410	41.68	1.641
					36.75	1.447	42.55	1.675	35.94	1.415	41.81	1.646

TOLERANCES: AS STATED

NOTES:

MARKING. THE NATO STOCK No. MANUFACTURERS CODE AND DATE CODE (SEE DEF-5001-C) TO BE LEGIBLY AND INDELIBLY MARKED ON COMPONENT AS INSTRUCTED ON CONTROL DRG.

PANEL PIERCING. THE DIMENSIONS BETWEEN CENTRES ARE RECOMMENDED MINIMUM SPACING BETWEEN ADJACENT ITEMS.

PLUGS AND SOCKETS, ELECTRICAL, PATTERN 104
CIRCULAR, SEALED, BRASS SHELLS WITH THREADED COUPLING

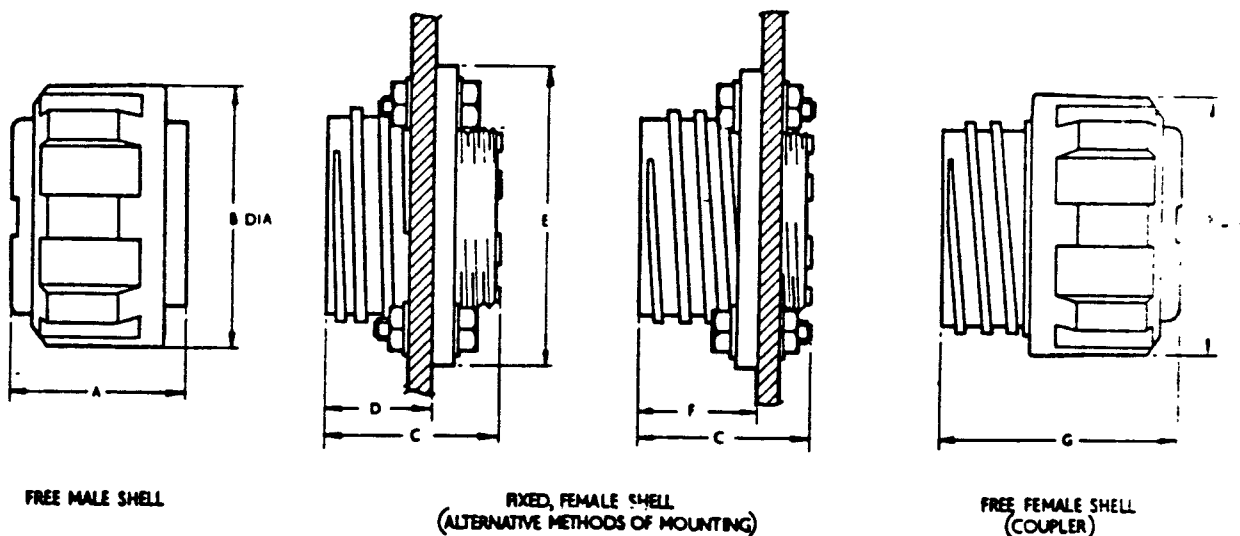

FREE MALE SHELL

FIXED, FEMALE SHELL
(ALTERNATIVE METHODS OF MOUNTING)

FREE FEMALE SHELL
(COUPLER)

SIZE	DIMENSIONS						
	A	B	C	D	E	F	G
1	1.05	1.28	1.05	.64	1.34	.77	.12
2	1.05	1.52	1.05	.64	1.66	.77	.12
3	1.20	1.93	1.15	.71	1.93	.86	.13

	FIXED ITEMS SUPPLIED WITH SHELL SIZE		
	1	2	3
SPECIAL BOLT	4BA .12	2BA .218	2BA .218
WASHER FLAT	4BA	2BA	2BA
NUT	4BA	2BA	2BA
WASHER, LOCK	4BA	2BA	2BA

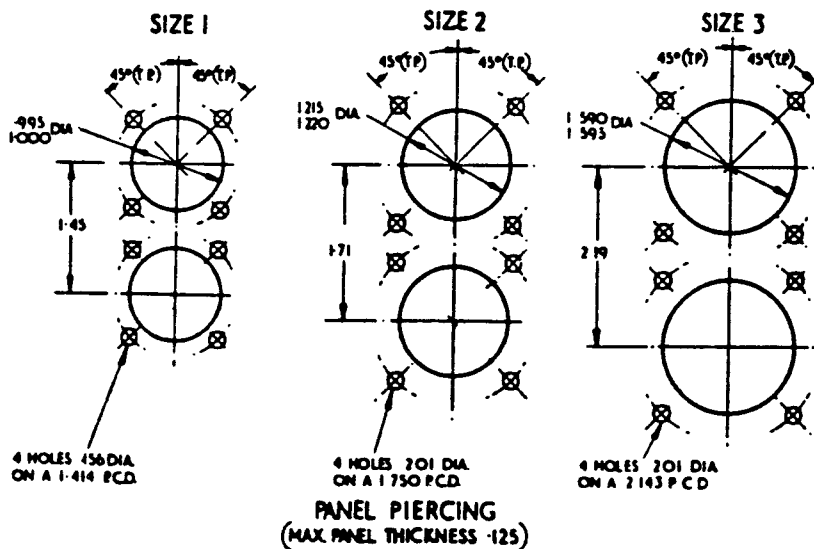

TOLERANCES: AS STATED

NOTES:

MARKING. THE NATO STOCK No. MANUFACTURERS CODE AND DATE CODE (SEE DEF-5001-2) TO BE LEGIBLY AND INDELIBLY MARKED ON COMPONENT AS INSTRUCTED ON CONTROL DRAWING.

PANEL PIERCING. THE DIMENSIONS BETWEEN CENTRES ARE THE RECOMMENDED MINIMUM SPACING BETWEEN ADJACENT ITEMS.

FIGURE 8

ACCESSORY SETS WITH ANGLED OUTLET
OPEN WIRING

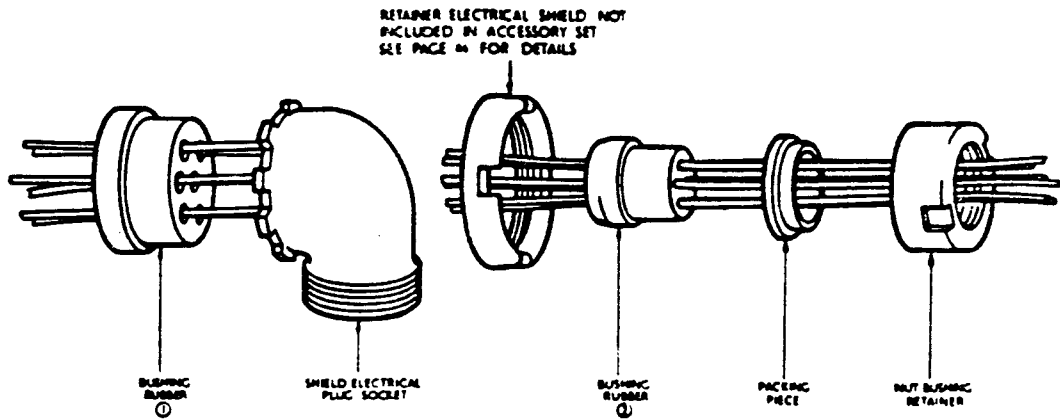

SHELL SIZE	No. OF CONTACTS AND CURRENT RATING	ACCEPTABLE CABLE DIAMETER IN INCHES	BUSHING, RUBBER (1)	SHIELD ELECTRICAL PLUG-SOCKET ANGLED	BUSHING RUBBER (2)	PACKING PIECE	NUT BUSHING RETAINER	ACCESSORY SET ELECTRICAL PLUG-SOCKET				
			TEMPERATURE CAT T4 ONLY -55°C TO +100°C		TEMPERATURE CAT T4 ONLY -55°C TO +100°C			DRAWING NUMBER CC/B 1234	DRAWING NUMBER CC/B 1177	DRAWING NUMBER CC/B 1233	DRAWING NUMBER CC/B 1045	DRAWING NUMBER CC/B 1296
			NATO STOCK NUMBER 3340-99	NATO STOCK NUMBER 3935-99	NATO STOCK NUMBER 5340-99			NATO STOCK NUMBER 5935-99	NATO STOCK NUMBER 5935-99	NATO STOCK NUMBER 5935-99		
1	2 = 19 AMP	.086 - .155	O14-9178	O14-2974	O14-9200	O14-9228	O14-2967	O14-8958				
	3 = 5 AMP	.035 - .075	O14-9179	O14-2973	O14-9201			O14-8970				
		.076 - .105	O14-9180		O14-9202			O14-9076				
	4 = 5 AMP	.035 - .075	O14-9181		O14-9203			O14-9078				
		.076 - .105	O14-9182		O14-9204			O14-9285				
	6 = 5 AMP	.035 - .075	O14-9183		O14-9205			O14-9288				
.076 - .105		O14-9184	O14-9206		O14-9292							
2	2 = 35 AMP	.136 - .220	O14-9185	O14-2975	O14-9207	O14-9229	O14-2968	O14-9294				
	3 = 19 AMP	.086 - .155	O14-9186	O14-2981	O14-9208			O14-9296				
		4 = 19 AMP	.086 - .155		O14-9187			O14-9209	O14-9503			
	6 = 5 AMP	.035 - .075	O14-9188		O14-9210			O14-9505				
		.076 - .105	O14-9189		O14-9211			O14-9507				
	12 = 5 AMP	.035 - .075	O14-9190		O14-9212			O14-9509				
	.076 - .105	O14-9191	O14-9213		O14-9511							
3	4 (1 = 60 AMP) (3 = 19 AMP)	.216 - .317	O14-9192	O14-2978	O14-9214	O14-9232	O14-2970	O14-9513				
		.086 - .155			O14-9215			O14-9515				
	5 (2 = 60 AMP) (3 = 19 AMP)	.216 - .317	O14-9193		O14-9216			O14-9517				
		.086 - .155	O14-9194		O14-9217			O14-9519				
	6 = 19 AMP	.086 - .155	O14-9195		O14-9218			O14-9521				
		.035 - .075	O14-9196		O14-9219			O14-9523				
	9 = 19 AMP	.076 - .105	O14-9197		O14-9220			O14-9525				
		.035 - .075	O14-9198		O14-9221			O14-9527				
25 = 5 AMP	.076 - .105	O14-9199										

FIGURE 9
-78-

ACCESSORY SETS WITH STRAIGHT OUTLET
OPEN WIRING

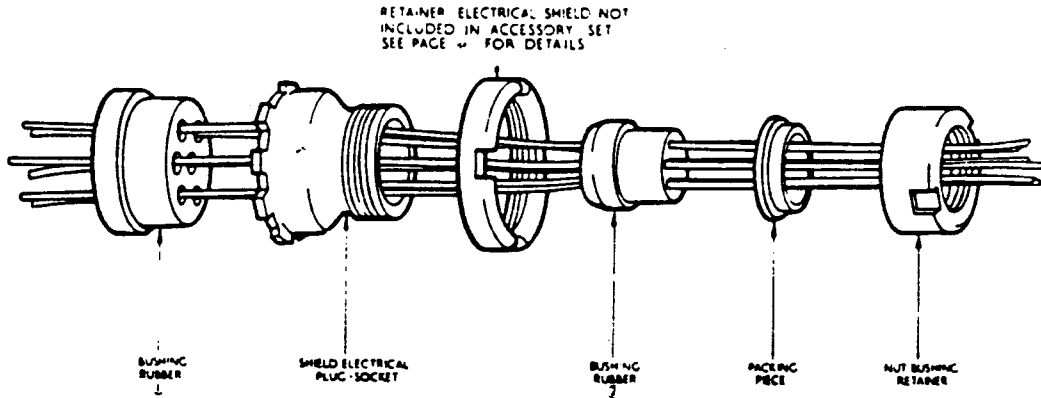

SHELL SIZE	No OF CONTACTS AND CURRENT RATING	ACCEPTABLE CABLE DIAMETER IN INCHES	BUSHING RUBBER ①	SHIELD ELECTRICAL PLUG-SOCKET	BUSHING RUBBER ②	PACKING PIECE	NUT BUSHING RETAINER	ACCESSORY SET ELECTRICAL PLUG-SOCKET
			TEMPERATURE CAT. T4 ONLY -55°C TO +100°C	STRAIGHT	TEMPERATURE CAT. T4 ONLY -55°C TO +100°C			
			DRAWING NUMBER CC/C 1234	DRAWING NUMBER CC/B 1176	DRAWING NUMBER CC/C 1233			
			NATO STOCK NUMBER 5340-99	NATO STOCK NUMBER 5935-99	NATO STOCK NUMBER 5340-99	NATO STOCK NUMBER 5935-99	NATO STOCK NUMBER 5935-99	NATO STOCK NUMBER 5935-99
1	2 x 19 AMP	.086 - .155	O14-9178	O14-2959	O14-9200	O14-9228	O14-2967	O 4-8 6 6 7
	3 x 5 AMP	.035 - .075	O14-9179	O14-2958	O14-9201	O14-9229	O14-2968	O 4-8 9 6 9
		.076 - .105	O14-9180		O14-9202			O 4-9 0 7 5
	4 x 5 AMP	.035 - .075	O14-9181		O14-9203			O 4-9 0 7 7
		.076 - .105	O14-9182		O14-9204			O14-9 2 8 4
	6 x 5 AMP	.035 - .075	O14-9183		O14-9205			O 4-9 2 8 6
.076 - .105		O14-9184	O14-9206		O 4-9 2 9 0			
2	2 x 35 AMP	.136 - .220	O14-9185	O14-2960	O14-9207	O14-9203	O14-2969	O 4-9 2 9 3
	3 x 19 AMP	.086 - .155	O14-9186	O14-2966	O14-9208	O14-9229	O14-2968	O 4-9 2 9 5
	4 x 19 AMP	.086 - .155	O14-9187		O14-9209			O 4-9 3 0 2
		.035 - .075	O14-9188		O14-9210			O 4-9 3 0 4
	6 x 5 AMP	.076 - .105	O14-9189	O14-9211	O 4-9 3 0 6			
		12 x 5 AMP	.035 - .075	O14-9190	O14-2960	O14-9212	O14-9230	O14-2969
	.076 - .105		O14-9191		O14-9213			O 4-9 3 1 0
3	4 (1 x 60 AMP) (3 x 19 AMP)	.216 - .317	O14-9192	O14-2963	O14-9214	O14-9232	O14-2970	O 4-9 3 1 2
		.086 - .155	O14-9193		O14-9215			O 4-9 3 1 4
	6 x 19 AMP	.086 - .155	O14-9194		O14-9216			O 4-9 3 1 5
	9 x 19 AMP	.086 - .155	O14-9195		O14-9217			O 4-9 3 1 8
		.035 - .075	O14-9196		O14-9218			O 4-9 3 2 0
	18 x 5 AMP	.076 - .105	O14-9197		O14-9219			O 4-9 3 2 2
		.035 - .075	O14-9198		O14-9220			O 4-9 3 2 4
	25 x 5 AMP	.076 - .105	O14-9199		O14-9221			O 4-9 3 2 6

FIGURE
-79-

ACCESSORY SETS WITH STRAIGHT OUTLET CABLES TO DEF STAN 61-12 (PART 5) TYPES A & P

DEF STAN 59 - 35 (PART 1)
SECTION 2/1

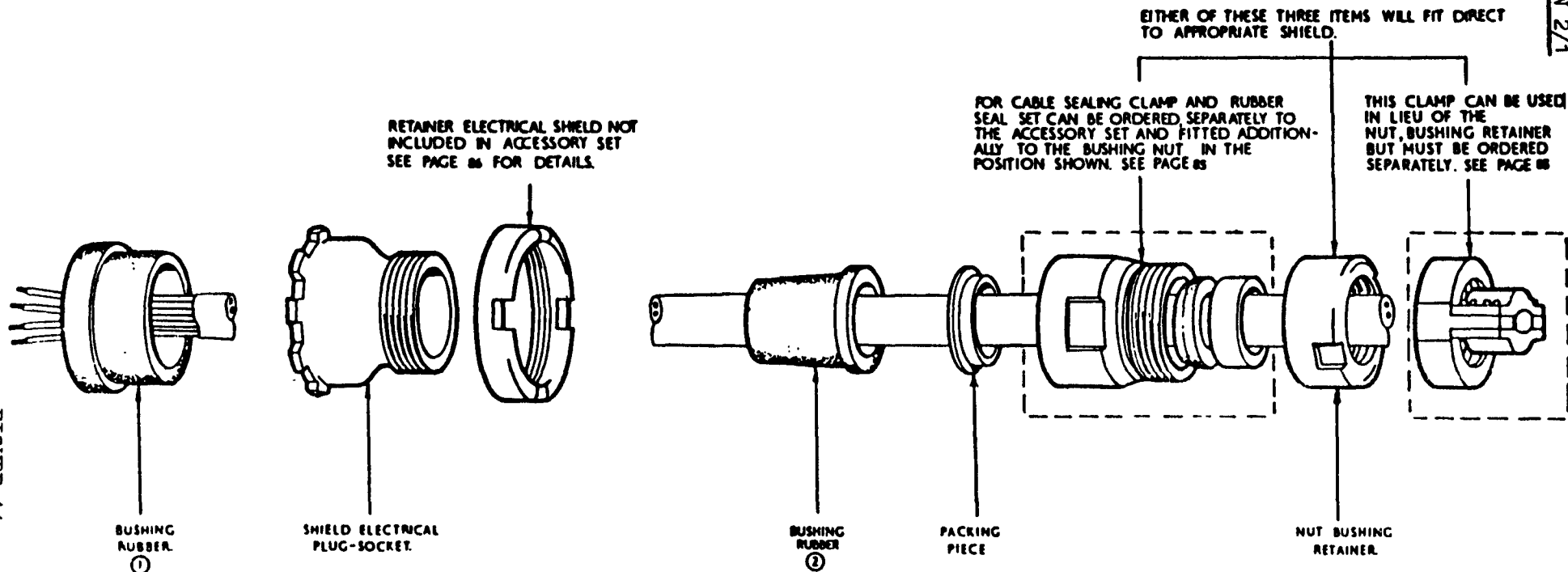

FIGURE 11
-80-

SHELL SIZE	No OF CONTACTS	CABLE IDENTIFICATION DEF. STAN. 61-12 (PART 5)		BUSHING RUBBER ①	SHIELD ELECTRICAL SOCKET	BUSHING RUBBER ②	PACKING PIECE	NUT BUSHING RETAINER	ACCESSORY SET ELECTRICAL PLUG-SOCKET	
		CODE No.	DIMENSIONS mm		TEMPERATURE CATEGORY T4 ONLY -55°C TO +100°C	STRAIGHT	TEMPERATURE CATEGORY T4 ONLY -55°C TO +100°C		FOR USE WITH SHIELD, ELECTRICAL OR CABLE SEALING CLAMP	TEMPERATURE CATEGORY T4
			MIN	MAX	DRAWING No. CC/B1175	DRAWING No. CC/B1176	DRAWING No. CC/B1183	DRAWING No. CC/B1388	DRAWING No. CC/B1043	DRAWING No. CC/B1295
				NATO STOCK No 5935-99-	NATO STOCK No 5935-99-	NATO STOCK No 5935-99-	NATO STOCK No 5935-99-	NATO STOCK No 5935-99-	NATO STOCK No 5935-99-	
	2	37-3-2P	8.5x 5.0	O11 - 9877	O14 - 2959	O97 - O107	O14 - 9228	O14 - 2967	O14 - 9270	
	3	16-2-3A	5.4 6.2		O14 - 2958	O97 - O108	O14 - 9229	O14 - 2968	O14 - 9272	
	4	16-2-4A	5.9 6.7		O14 - 2961	O97 - O109	O14 - 9230	O14 - 2972	O14 - 9276	
	6	16-2-6A	6.9 7.7		O14 - 2960	O97 - O111	O14 - 9232	O14 - 2969	O14 - 9278	
	4	37-3-4P	9.8 10.8	O97 - 0059	O14 - 2963	O97 - O240	O14 - 9231	O14 - 2970	O14 - 9280	
	12	16-2-12A	9.1 9.9		O14 - 296	O97 - O111	O14 - 9231	O14 - 2970	O14 - 9282	
	18	16-2-18A	10.5 11.5	O97 - 0060						
	25	16-2-25A	12.6 13.6							

ACCESSORY SETS WITH ANGLED OUTLET CABLES TO DEF STAN 61-12 (PART 5) TYPES A & P

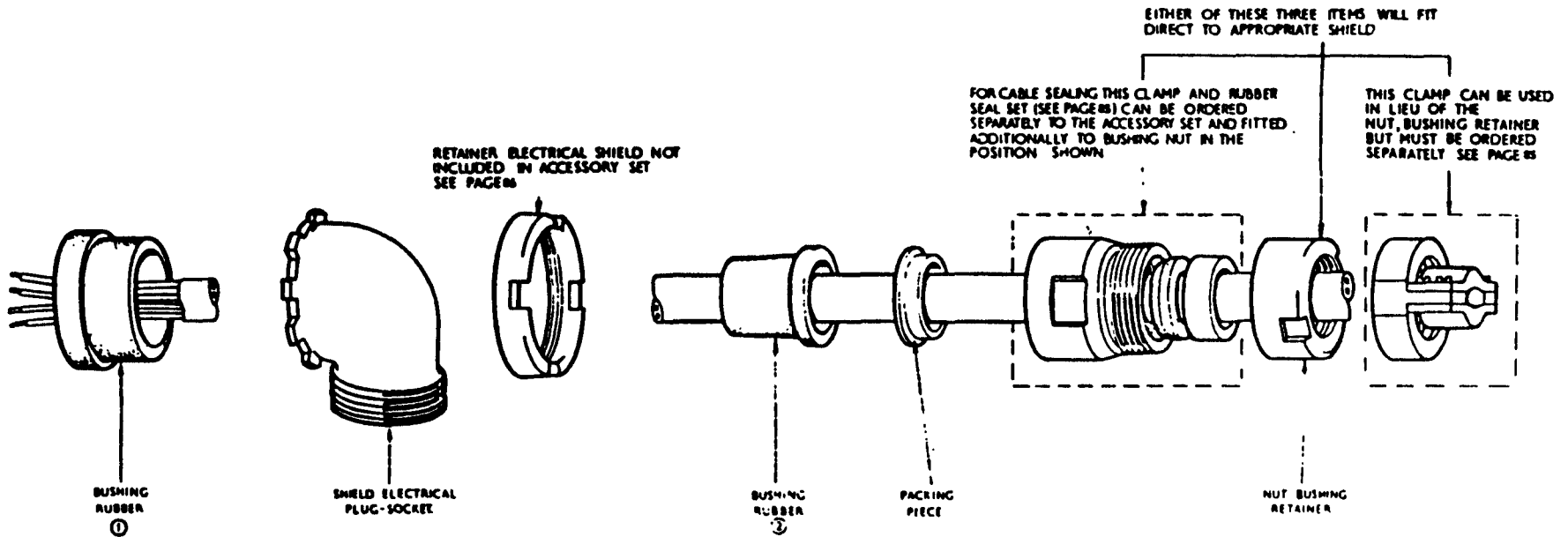

FIGURE 12
-81-

SHELL SIZE	No. OF CONTACTS	CABLE IDENTIFICATION DEF. STAN. 61-12 (PART 5)		BUSHING RUBBER ①	SHIELD ELECTRICAL SOCKET	BUSHING RUBBER ②	PACKING PIECE	NUT BUSHING RETAINER	ACCESSORY SET ELECTRICAL PLUG-SOCKET
		CODE No.	DIMENSIONS mm MIN. MAX.	TEMPERATURE CATEGORY T4 ONLY -55°C TO +100°C DRAWING No. CC/B1175 NATO STOCK No. 5933-99-	ANGLED DRAWING No. CC/B1177 NATO STOCK No. 5933-99-	TEMPERATURE CATEGORY T4 ONLY -55°C TO +100°C DRAWING No. CC/B1183 NATO STOCK No. 5933-99-		FOR USE WITH SHIELD, ELECTRICAL OR CABLE SEALING CLAMP. DRAWING No. CC/B1045 NATO STOCK No. 5933-99-	TEMPERATURE CATEGORY T4 DRAWING No. CC/B 1295 NATO STOCK No. 5933-99-
1	2	37-3-2P	8.57 9.32 5.0 5.8	O11-9877	O14-2974	O97-0107	O14-9228	O14-2967	O14-9271
	3	16-2-3A	5.4 6.2		O14-2973	O97-0108	O14-9229	O14-2968	O14-9273
	4	16-2-4A	5.9 6.7						
	6	16-2-6A	6.9 7.7						
2	4	37-3-4P	9.8 10.8	O97-0059	O14-2976	O97-0109	O14-9230	O14-2972	O14-9277
	12	16-2-12A	9.1 9.9		O14-2975	O97-0111	O14-9232	O14-2969	O14-9277
3	18	16-2-18A	11.5 11.5	O97-01060	O14-2978	O97-0240	O14-9231	O14-2970	O14-9271
	25	16-2-25A	12.6 13.6		O14-2978	O97-0111	O14-9231	O14-2970	O14-9271

ACCESSORY SETS WITH STRAIGHT OUTLET. CABLES TO DEF STAN 61-12 (PART 5) TYPES C, J, & R

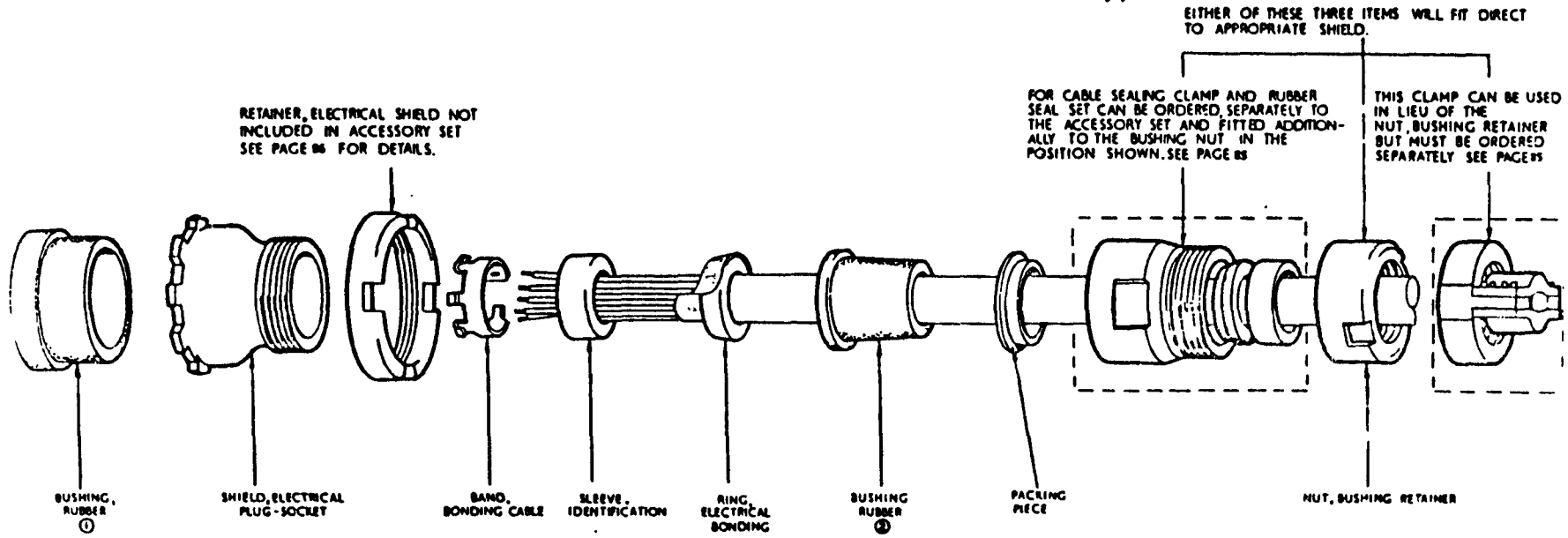
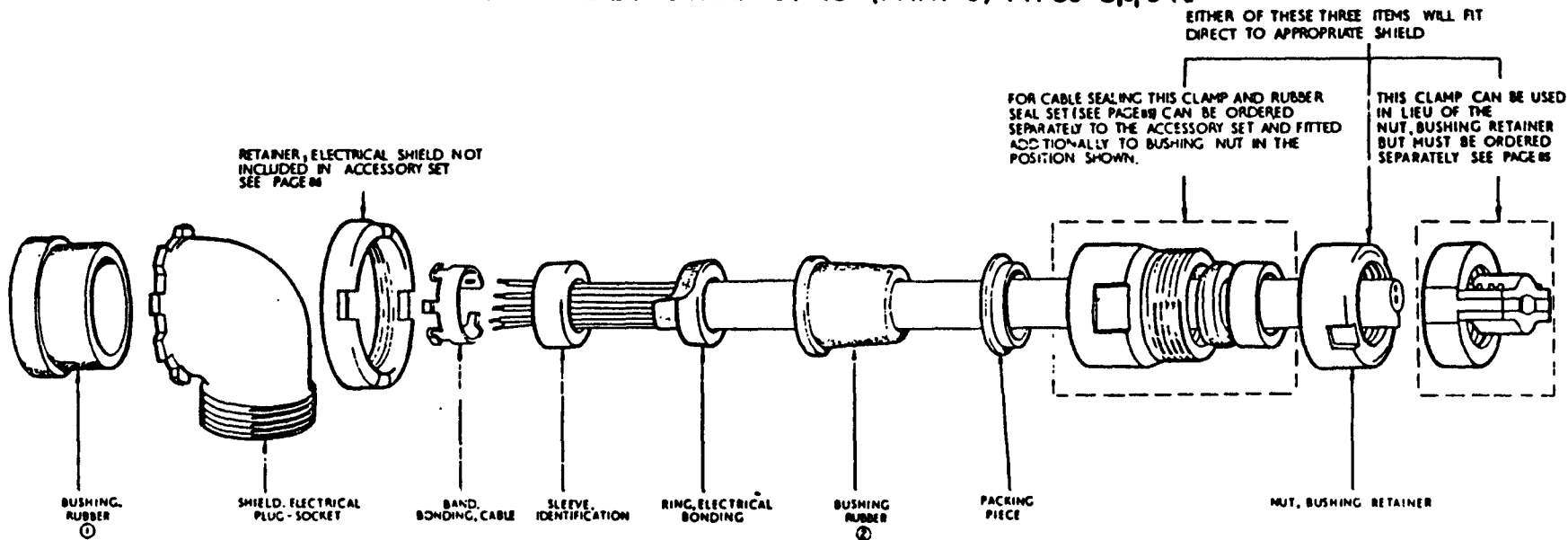

FIGURE 13
-P2-

SHELL SIZE	No OF CONTACTS	CABLE IDENTIFICATION DEF STAN 61-12 (PART 5)	BUSHING, RUBBER ①	SHIELD, ELECTRICAL PLUG-SOCKET	BAND, BONDING, CABLE	SLEEVE, IDENTIFICATION	RING, ELECTRICAL BONDING	BUSHING, RUBBER ②	PACKING PIECE	NUT, BUSHING RETAINER	ACCESSORY SET, ELECTRICAL PLUG-SOCKET	
			TEMPERATURE CATEGORY T4 ONLY -55°C TO +100°C	STRAIGHT	FOR USE WITH 16-2-6J AND 16-2-18J CABLES ONLY	TEMPERATURE CATEGORY T4 -55°C + 100°C		TEMPERATURE CATEGORY T4 -55° TO +100°C		FOR USE WITH SHIELD ELECTRICAL OR CABLE SEALING CLAMP	TEMPERATURE CATEGORY T4	
		CODE No.	DRAWING No CC/8 1175	DRAWING No CC/8 1176	DRAWING No CC/5 1181	DRAWING No CC/5 1184	DRAWING No CC/5 1182	DRAWING No CC/8 1183	DRAWING No CC/3 1388	DRAWING No CC/5 1045	DRAWING No CC/8 1293	
		MIN MAX	NATO STOCK No 5935-99	NATO STOCK No 5935-99	NATO STOCK No 5975-99	NATO STOCK No 5340-99	NATO STOCK No 5975-99	NATO STOCK No 5935-99	NATO STOCK No 5935-99	NATO STOCK No 5935-99	NATO STOCK No 5935-99	
I	2	37-3-2R 7.0 7.3	O11-9877	O14-2959			O14-2938	O97-0107	O14-9228	O14-2967	O14-9234	
	3	16-2-3C 6.4 7.2		O14-2958		O97-0114	O14-2939	O97-0108	O14-9229	O14-2958	O14-9236	
	4	16-2-4C 6.9 7.7										
	6	16-2-6C 7.9 8.7										
C	4	37-3-4R 10.8 11.8	O97-0059	O14-2961		O97-0115	O14-2942	O97-0109	O14-9230	O14-2972	O14-9240	
	6	16-2-6J 12.9 13.9		O14-2962	O14-2936	O97-0116	O14-2940	O97-0240	O14-9231	O14-2970	O14-9244	
	12	16-2-12C 10.0 11.0		O14-2960		O97-0115	O14-2942	O97-0111	O14-9232	O14-2969	O14-9242	
J	18	16-2-18C 11.5 12.5	O97-0060	O14-2963		O97-0116	O14-2941	O97-0240	O14-9231	O14-2970	O14-9246	
		16-2-18J 17.6 18.8		O14-2964	O14-2937	O97-0017	O14-2943	O97-0112	O14-9233	O14-2971	O14-9250	
	25	16-2-25C 13.6 14.6		O14-2963		O97-0016	O14-2941	O97-0110	O14-9231	O14-2970	O14-9248	

ACCESSORY SETS WITH ANGLED OUTLET CABLES TO DEF. STAN. 61-12 (PART 5) TYPES C, J, & R.



-83-
FIGURE 14.

SHELL SIZE	No OF CONTACTS	CABLE IDENTIFICATION DEF STAN 61-12 (PART 5)		BUSHING RUBBER ①	SHIELD ELECTRICAL PLUG-SOCKET	BAND BONDING CABLE	SLEEVE IDENTIFICATION	RING ELECTRICAL BONDING	BUSHING RUBBER ②	PACKING PIECE	MUT. BUSHING RETAINER	ACCESSORY SET ELECTRICAL PLUG-SOCKET
		CODE No	DIMENSIONS mm MIN MAX	TEMPERATURE CATEGORY T4 ONLY -55°C TO +100°C	ANGLED	FOR USE WITH DEF IO TYPE J CABLE ONLY	TEMPERATURE CATEGORY T4 -55°C + 100°C	TEMPERATURE CATEGORY T4 -55°C TO +100°C	FOR USE WITH SHIELD ELECTRICAL OR CABLE SEALING CLAMP	TEMPERATURE CATEGORY T4		
		DRAWING No CC/B 1175	DRAWING No CC/B 1177	DRAWING No CC/S 1181	DRAWING No CC/S 1184	DRAWING No CC/S 1182	DRAWING No CC/S 1183	DRAWING No CC/B 1398	DRAWING No CC/B 1045	DRAWING No CC/B 1253		
		NATO STOCK No 5935-99	NATO STOCK No 5935-99	NATO STOCK No 5975-99	NATO STOCK No 5340-99	NATO STOCK No 5975-99	NATO STOCK No 5935-99	NATO STOCK No 5935-99	NATO STOCK No 5935-99	NATO STOCK No 5935-99	NATO STOCK No 5935-99	NATO STOCK No 5935-99
1	2	37-3-2R	5.5 6.0 10.1 10.8	011-9877	014-2974		097-0114	014-2938	097-0107	014-9228	014-2967	014-9235
	3	16-2-3C	6.4 7.2									
	4	16-2-4C	6.9 7.7									
	6	16-2-6C	7.9 8.7									
2	4	37-3-4R	10.8 11.8	097-0059	014-2976	014-2936	097-0115	014-2942	097-0109	014-9230	014-2972	014-9241
	6	16-2-6J	12.9 13.9									
	12	16-2-12C	10.0 11.0									
3	18	16-2-18C	11.5 12.5	097-0060	014-2978	014-2937	097-0116	014-2941	097-0240	014-9231	014-2970	014-9245
	17	16-2-17C	11.6 11.8									
	15	16-2-15C	11.6 14.6									

DEF STAN 5 - SECTION 2/1

DEF STAN 59 - 35 (PART 1)
SECTION 2/1

ACCESSORY SETS WITH STRAIGHT OUTLET
 CABLES TO DEF STAN 61 12 (PART 4) TYPES A&C, AND (PART 5) TYPES A&C.

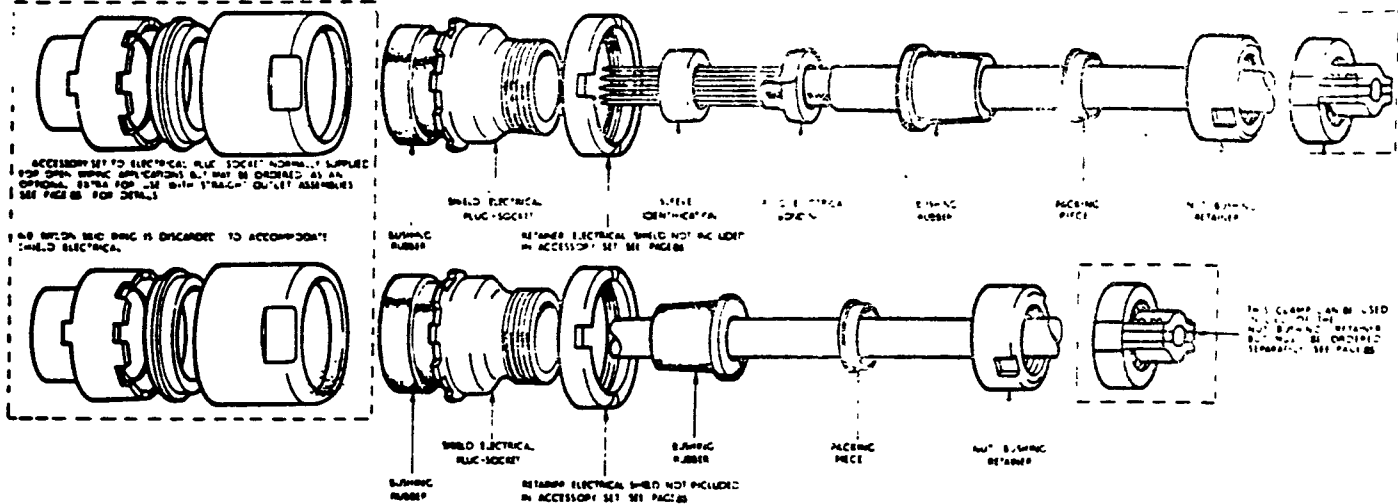

SHELL SIZE	NO. OF CONTACTS	CABLE IDENTIFICATION	BUSHING RUBBER	SHIELD ELECTRICAL PLUG-SOCKET	SLEEVE IDENTIFICATION	RING ELECTRICAL BONDING	BUSHING RUBBER	PACKING PIECE	NUT BUSHING RETAINER	ACCESSORY SET ELECTRICAL PLUG-SOCKET
			TEMPERATURE CATEGORY T4 -55°C TO +100°C	STRAIGHT	TEMPERATURE CATEGORY T4 -55°C TO +100°C		TEMPERATURE CATEGORY T4 -55°C TO +100°C			FOR USE WITH SHIELD ELECTRICAL OR CABLE SEALING CLAMP
CODE No.		DIMENSIONS mm	DRAWING No. CC/B 1175	DRAWING No. CC/B 1176	DRAWING No. CC/B 1184	DRAWING No. CC/B 1187	DRAWING No. CC/B 1185	DRAWING No. CC/B 1288	DRAWING No. CC/B 1043	DRAWING No. CC/B 1298
		MIN. MAX.	NATO STOCK No. 5923-99	NATO STOCK No. 5923-99	NATO STOCK No. 5340-99	NATO STOCK No. 5923-99	NATO STOCK No. 5923-99	NATO STOCK No. 5923-99	NATO STOCK No. 5923-99	NATO STOCK No. 5923-99

DEF STAN 61-12 (PART 5)

1	12	10-2-12A	9 1 9 9								
	12	10-2-12C	10 0 11 0								
2	26	10-2-25A	12 6 13 6								
	26	10-2-25C	13 0 14 6	097-0050	014-2962	097-0116	014-2941	097-0110	014-9231	014-2970	04-9289
3	37	10-2-36C	15 3 16 7								
	62	10-2-60C	1 20 3								

DEF STAN 61-12 (PART 4)

1	12	7-2-12A	5 8 6 4 <th></th> <th></th> <th></th> <th></th> <th></th> <th></th> <th></th> <th></th>								
	12	7-2-12C	6 6 7 2	011-0877	014-2938	097-0114	014-2939	097-0108	014-9229	014-2968	04-9287
2	26	7-2-25A	8 4 19 0								
	26	7-2-25C	9 2 19 8	097-0050	014-2960	097-0115	014-2942	097-0111	014-9232	014-2969	04-9291
	37	7-2-36A	9 3 10 1								
	37	7-2-36C	10 4 11 2								
	62	7-2-60A	1 2 0 2 8								
3	62	7-2-60C	1 0 13 8	097-0060	014-2963	097-0116	014-2941	097-0110	014-9231	014-2970	04-9297

NOTE: - COMPLETE ACCESSORY SETS AVAILABLE FOR UNSHIELDED CABLE SIZES ARE NOT AVAILABLE.

ADDITIONAL ACCESSORIES

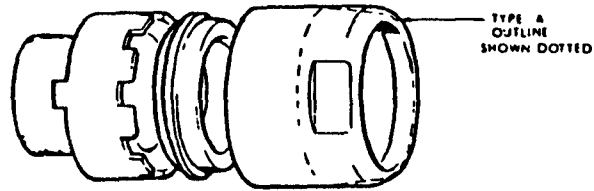

ACCESSORY SET, ELECTRICAL PLUG-SOCKET
(HIGH DENSITY)

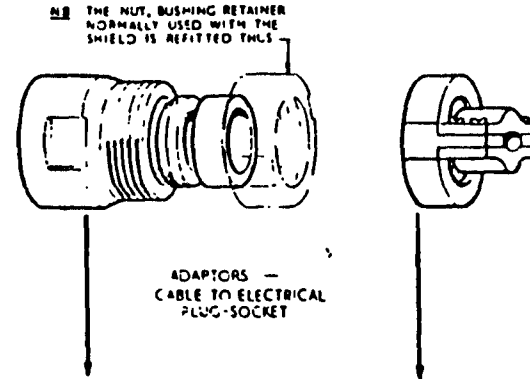

DRAWING NUMBER	NATO STOCK No	SHELL SIZE	CONTACT ARRANGEMENT			
			No OFF	PLUG OR SOCKET		
CC/C 1386/1	5935-99-014-9310	1	12	P	TYPE A FOR USE WITH ALUMINIUM FREE MALE SHELL AND ALL BRASS CONNECTOR STYLES	
• 2	• 9311			S		
• 3	• 9312	2	26	P		
• 4	• 9313			S		
• 5	• 9314	3	37	P		
• 6	• 9315			S		
• 7	• 9316			P		
• 8	• 9317			S		
• 9	• 9318	1	12	P		TYPE B FOR USE WITH ALL FEMALE ALUMINIUM CONNECTOR STYLES
• 10	• 9319			S		
• 11	• 9320	2	26	P		
• 12	• 9321			S		
• 13	• 9322	3	37	P		
• 14	• 9323			S		
• 15	• 9324			P		
• 16	• 9325			S		

TYPE I		TYPE II		MAY BE USED WITH SHIELD ELECTRICAL PLUG-SOCKET LISTED BELOW	
DRAWING NUMBER	NATO STOCK No	DRAWING NUMBER	NATO STOCK No	STRAIGHT	ANGLED
				NATO STOCK No	NATO STOCK No
CC/B/1237/1	NOT PROVISIONED	CC/B/1238/1	5935-99-014-2982	5935-99-014-2958	5935-99-014-2973
				or	or
				5935-99-014-2966	5935-99-014-2981
CC/B/1237/2	NOT PROVISIONED	CC/B/1238/2	5935-99-014-2983	5935-99-014-2959	5935-99-014-2974
CC/B/1237/3		CC/B/1238/3	5935-99-014-2984	5935-99-014-2960	5935-99-014-2975
CC/B/1237/4		5935-99-014-9225	CC/B/1238/4	5935-99-014-2985	5935-99-014-2961
CC/B/1237/5	NOT PROVISIONED	CC/B/1238/5	5935-99-014-2986	5935-99-014-2962	5935-99-014-2977
				or	or
CC/B/1237/6	5935-99-014-9227	CC/B/1238/6	5935-99-014-2987	5935-99-014-2963	5935-99-014-2978
				or	or
				5935-99-014-2964	5935-99-014-2979
				or	or
				5935-99-014-2965	5935-99-014-2980

-85-
FIGURE 16

PLUGS AND SOCKETS, ELECTRICAL PATTERNS FOR SPARES

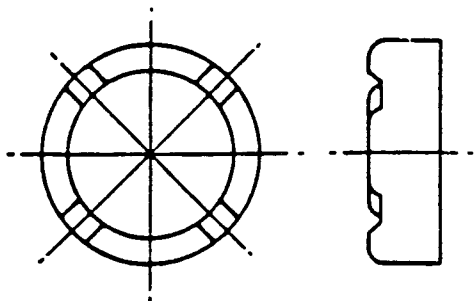

RETAINER, ELECTRICAL SHIELD

SHELL SIZE	THREAD	DRAWING No.	NATO STOCK No.
1	-7969 x 26 TPI	CC/B 1218/1	5935-99-013-9160
	-8431 x 20 TPI	CC/B 1218/4	5935-99-013-9163
2	1-0156 x 26 TPI	CC/B 1218/2	5935-99-013-9161
	1-0625 x 20 TPI	CC/B 1218/5	5935-99-013-9164
3	1-4062 x 26 TPI	CC/B 1218/3	5935-99-013-9162
	1-4375 x 20 TPI	CC/B 1218/6	5935-99-013-9165

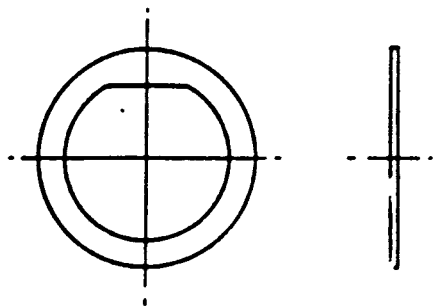

WASHER LOCK

SIZE	DRAWING No.	NATO STOCK No.
1	CC/B 1220/1	5310-99-013-9166
2	CC/B 1220/2	5310-99-013-9167
3	CC/B 1220/3	5310-99-013-9168
3A	CC/B 1220/4	5310-99-014-9177

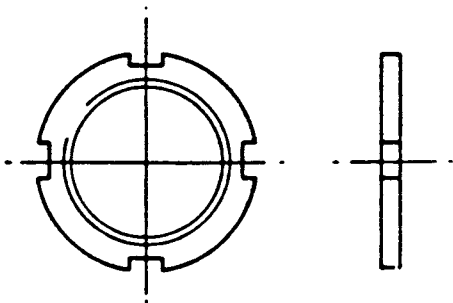

NUT, PLAIN ROUND

SIZE	DRAWING No.	NATO STOCK No.
1	CC/B 1219/1	5310-99-013-9169
2	CC/B 1219/2	5310-99-013-9170
3	CC/B 1219/3	5310-99-013-9171
3A	CC/B 1219/4	5310-99-014-9176

THESE ITEMS ARE NORMALLY SUPPLIED AS PARTS OF THE APPROPRIATE ASSEMBLIES. THEY NEED ONLY BE ORDERED SEPARATELY TO REPLACE LOST OR DAMAGED PARTS.

PLUGS AND SOCKETS, ELECTRICAL. PATTERN 104

COVERS, ELECTRICAL PLUG/SOCKET (ALUMINIUM)

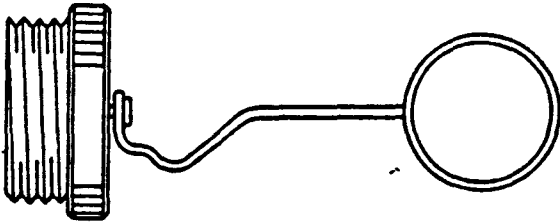

FOR MALE SHELLS

SIZE	DRAWING No	N.A.T.O STOCK No
1	CC/B/1185/1	5935-99-097-0051
2	CC/B/1185/2	5935-99-097-0052
3	CC/B/1185/3	5935-99-097-0054

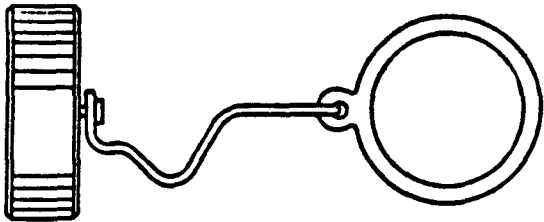

FOR FEMALE SHELLS

SIZE	DRAWING No.	N.A.T.O STOCK No
1	CC/B/1186/1	5935-99-097-0055
2	CC/B/1186/2	5935-99-097-0056
3	CC/B/1186/3	5935-99-097-0057

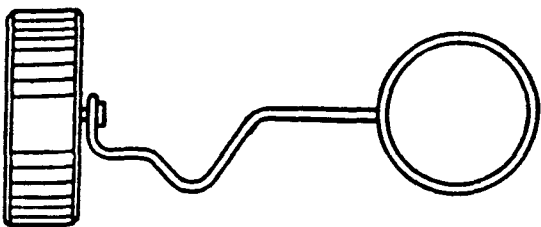

FOR COUPLING ASSEMBLIES

SIZE	DRAWING No	N.A.T.O. STOCK No
1	CC/B/1187/1	5935-99-097-0058
2	CC/B/1187/2	5935-99-097-0059
3	CC/B/1187/3	5935-99-097-0060

PLUGS AND SOCKETS, ELECTRICAL, PATTERN 104

COVERS ELECTRICAL PLUG/SOCKET
(POLYTHENE AND BRASS)

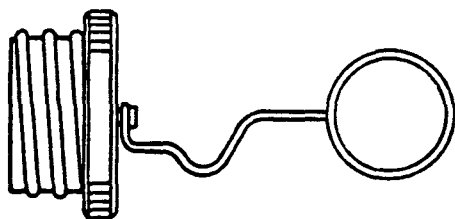

FOR MALE SHELLS

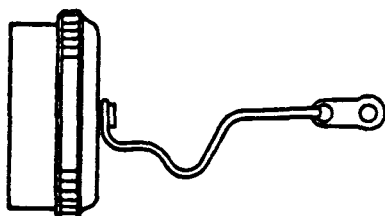

FOR FEMALE SHELLS

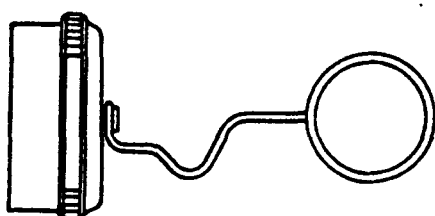

FOR COUPLING ASSEMBLIES

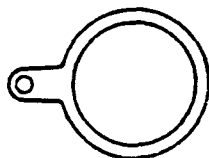

FOR ALUMINIUM COARSE THREAD
IN CONJUNCTION WITH CC/B 1202 & CC/B 1205

POLYTHENE

SIZE	DRG No	NATO STOCK No
1	CC/B 1201 / 1	5935-99-013-9181
2	CC/B 1201 / 2	5935-99-013-9182
3	CC/B 1201 / 3	5935-99-013-9183
3A	CC/B 1201 / 4	5935-99-014-9298

BRASS

SIZE	DRG No	NATO STOCK No
1	CC/B 1204 / 1	5935-99-013-9184
2	CC/B 1204 / 2	5935-99-013-9185
3	CC/B 1204 / 3	5935-99-013-9186
3A	CC/B 1204 / 4	5935-99-014-9301

POLYTHENE

SIZE	DRG No	NATO STOCK No
1	CC/B 1202 / 1	5935-99-013-9187
2	CC/B 1202 / 2	5935-99-013-9188
3	CC/B 1202 / 3	5935-99-013-9189
3A	CC/B 1202 / 4	5935-99-014-9299

BRASS

SIZE	DRG No	NATO STOCK No
1	CC/B 1205 / 1	5935-99-013-9190
2	CC/B 1205 / 2	5935-99-013-9191
3	CC/B 1205 / 3	5935-99-013-9192
3A	CC/B 1205 / 4	5935-99-014-9302

POLYTHENE

SIZE	DRG No	NATO STOCK No
1	CC/B 1203 / 1	5935-99-013-9193
2	CC/B 1203 / 2	5935-99-013-9194
3	CC/B 1203 / 3	5935-99-013-9195
3A	CC/B 1203 / 4	5935-99-014-9300

BRASS

SIZE	DRG No	NATO STOCK No
1	CC/B 1206 / 1	5935-99-013-9196
2	CC/B 1206 / 2	5935-99-013-9197
3	CC/B 1206 / 3	5935-99-013-9198
3A	CC/B 1206 / 4	5935-99-014-9303

SIZE	DRG No	NATO STOCK No
1	CC/B 1392 / 1	5935-99-014-9528
2	CC/B 1392 / 2	5935-99-014-9529
3	CC/B 1392 / 3	5935-99-014-9530

RING, CONNECTING.

PLUGS AND SOCKETS, ELECTRICAL. PATTERN 104
SPANNER KIT

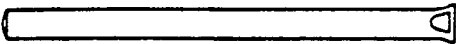
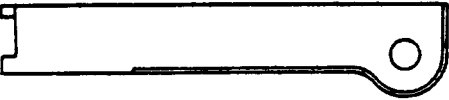
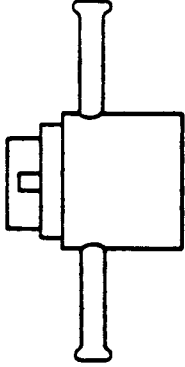
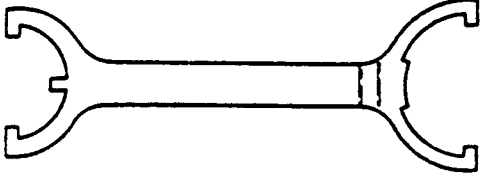
DESCRIPTION	SIZE	NATO STOCK No	DRAWING No
 BAR TOMMY	NOT APPLICABLE	5120-99-097-0143	CC/B 1269
 SPANNER WRENCH	1	5120-99-097-0133	CC/B/1190/1
	2	5120-99-097-0137	CC/B/1190/2
	3	5120-99-097-0140	CC/B/1190/3
 HOLDING TOOL, ELECTRICAL PLUG-SOCKET	1	5120-99-056-9019	CC/C/1192/1
	2	5120-99-056-9020	CC/C/1192/2
	3	5120-99-056-9021	CC/C/1192/3
 SPANNER, WRENCH	1	5120-99-013-9199	CC/B/1231/1
	2	5120-99-013-9200	CC/B/1231/2
	3	5120-99-013-9201	CC/B/1231/3
	3A	5120-99-014-9308	CC/B/1231/4

TOOL KIT, NATO STOCK No. 5180-99-014-9309

COMPRISES ALL ITEMS DETAILED ON THIS PAGE

ANNEX APattern 10L, Plugs and Sockets.DEF STAN 61-12 (PART 5) WIRES, CORDS AND CABLE, ELECTRICAL.TYPE 'B' CONSTRUCTION.

1. No provision is made in this specification for the use of type 'B' cables (as type A plus outer metal screen) with an appropriate accessory set.
2. For maintenance purposes replacement items for existing type 'B' installations are listed hereunder.

Cable No	Packing, Preformed	Sleeve, Electrical Plug-Socket	
	Drawing No CC/B1180 Nato Stock No 5935-99-	INNER Drg No CC/B1179 Nato Stock No 5935-99-	OUTER Drg No CC/B1178 Nato Stock No 5935-99-
16-2-2B 16-2-3B 16-2-4B 16-2-6B	097-0088	014-2923	014-2916
16-2-12B	097-0091	014-2926	014-2919
16-2-18B	097-0239	014-2928	014-2921
16-2-25B	097-0090	014-2928	014-2921

Note: The addition of the ① Bushing, Rubber; Shield, Electrical Plug-Socket, and Nut, Bushing Retainer applicable to the equivalent type A cable complete the items required to facilitate connection. See pages 80 and 81.