

As you are now the owner of this document which should have come to you for free, please consider making a donation of £1 or more for the upkeep of the (Radar) website which holds this document. I give my time for free, but it costs me in excess of £300 a year to bring these documents to you. You can donate here <https://blunham.com/Radar>

Please do not upload this copyright pdf document to any other website. Breach of copyright may result in a criminal conviction.

This document was generated by me Colin Hinson from a document held at Henlow Signals Museum. It is presented here (for free) and this version of the document is my copyright (along with the Signals Museum) in much the same way as a photograph would be. Be aware that breach of copyright can result in a criminal record.

The document should have been downloaded from my website <https://blunham.com/Radar>, if you downloaded it from elsewhere, please let me know (particularly if you were charged for it). You can contact me via my Genuki email page:

<https://www.genuki.org.uk/big/eng/YKS/various?recipient=colin>

You may not copy the file for onward transmission of the data nor attempt to make monetary gain by the use of these files. If you want someone else to have a copy of the file, please point them at the website (<https://blunham.com/Radar>).

Please do not point them at the file itself as the file may move or be updated.

I put a lot of time into producing these files which is why you are met with this page when you open the file.

In order to generate this file, I need to scan the pages, split the double pages and remove any edge marks such as punch holes, clean up the pages, set the relevant pages to be all the same size and alignment. I then run Omnipage (OCR) to generate the searchable text and then generate the pdf file.

Hopefully after all that, I end up with a presentable file. If you find missing pages, pages in the wrong order, anything else wrong with the file or simply want to make a comment, please drop me a line (see above).

It is my hope that you find the file of use to you personally – I know that I would have liked to have found some of these files years ago – they would have saved me a lot of time !

Colin Hinson

In the village of Blunham, Bedfordshire.

WIRELESS TRANSMISSION

EDITED BY
F. J. CAMM

WIRELESS TRANSMISSION

By the same Author

Practical Wireless Encyclopaedia

Practical Wireless Service Manual

Practical Wireless Circuits

Everyman's Wireless Book

Newnes' Television Manual

Wireless Coils, Chokes and Transformers

Newnes' Short Wave Manual

The Superhet Manual

Radio Engineer's Pocket Book

Newnes' Radio Valve Data Pocket Book

Radio Training Manual

WIRELESS TRANSMISSION

BY

F. J. CAMM

Editor of

"Practical Wireless"

WITH 120 ILLUSTRATIONS

LONDON

GEORGE NEWNES LIMITED

TOWER HOUSE, SOUTHAMPTON STREET, STRAND, W.C.2

<i>First Published</i>	.	.	1938
<i>Second Edition</i>	.	.	1938
<i>Third Edition</i>	.	.	1939
<i>Fourth Edition</i>	.	.	1939
<i>Fifth Edition</i>	.	.	1941
<i>Sixth Edition</i>	.	.	1941
<i>Seventh Edition</i>	.	.	1943
<i>Eighth Edition</i>	.	.	1945

*Made and Printed in Great Britain
by Jarrold & Sons, Ltd., Norwich*

EDITOR'S PREFACE

THE Amateur Transmitter has performed valuable work for broadcasting, for the experiments conducted by those operating amateur transmitting sets have been used not only by the broadcasting authorities, but also by wireless receiver manufacturers, and in many respects the amateur transmitter may be regarded as the unofficial C.I.D. of radio. Their interest continues in spite of the war-time ban on amateur transmitting. There are several thousand amateur transmitters in this country. It is estimated that there are 70,000 amateur transmitters throughout the world.

Interest in amateur transmission is growing, for most of the keen wireless experimenters are turning to it as a change from building experimental broadcast receivers.

The book covers all aspects of the subject from the obtaining of an amateur transmitting licence to the building of transmitters.

Readers are advised to take *Practical Wireless*—9d. every month.

F. J. CAMM

WIRELESS TRANSMISSION

CHAPTER I

PRELIMINARIES

HOWEVER keen a wireless constructor may be on receiving and logging wireless transmissions, there comes a time when he has a desire to be able to reverse the procedure, and take part in the ever-increasing activities of the many thousands of amateur transmitters.

The desire is generally created—in genuine wireless enthusiasts—if any time is spent on the short waves, listening to amateur transmitters working other stations over distances varying between a few miles and several thousands. One cannot help being impressed by the spirit of friendship which exists between all transmitters, irrespective of nationality and tongue, and the feeling that the station owners are getting ninety per cent out of wireless, enjoying it to the full apart from contributing—to a very great extent—to the development and progress of the science.

The amateur who intends to take up transmitting, however, often finds that it is not too easy to secure all the necessary details. The object of this book, therefore, is to put the whole matter quite clearly before those interested, and to describe, from the fundamental stages upwards, the design and construction of transmitters suitable for amateur use, but it must be fully appreciated that such equipment must not be operated until the licence requirements have been fully satisfied. This is not only for the sake of conforming to regulations, it is also to protect the facilities already granted to amateur transmitters as a whole.

To avoid any misunderstanding, unless the would-be amateur transmitter is prepared to devote a reasonable amount of time and study to the subject, to enable him to overcome the preliminary details, then he may as well abandon the idea of becoming the proud owner of a transmitting station.

Preliminary and Essential Details.—However anxious you are to reach the transmitting stage, it is useless for you to attempt to skip the preliminary details, even if they are dry and uninteresting. The quicker the ground work is done, the quicker the licence application can be made.

Licences.—When a fair amount of time has been spent on short-wave reception, it is feasible to think about applying for a transmitting licence. It is not necessary to have the transmitter assembled before doing this, as it is highly possible that some little time will elapse between the time of application, and the granting of the official Licence.

There are two forms of licence, the A.A. or Artificial Aerial, and the Full Licence.

Artificial Aerial.—The licence granted under this heading covers the use of transmitting apparatus which is not coupled to an outside or radiating aerial. A dummy or artificial aerial has to be used, and the whole equipment so designed that it will not radiate signals outside the premises in which it is being used. A great number of constructors have the opinion that such facilities are of little use. That is not so, in fact, every constructor who wishes to become a full licence holder should commence his activities by securing an A.A. licence, as most valuable information and experience can be obtained by the intelligent use of apparatus which comes within the scope of the licence. It must be appreciated, that apart from the Artificial Aerial, the equipment is identical with a proper transmitter, and that every form of test can be made, as regards modulation, circuit design and characteristics. The cost of an A.A. licence is 10s. per annum. Tests have not to be passed, but it is necessary that certain technical details are completed on the application form which can be obtained from the Engineer-in-Chief, Radio Section, G.P.O., Armour House, London, E.C.1. It usually takes about three weeks for the licence to be granted.

Full Licence.—When an application is made for a Full Licence, it is necessary to convince the authorities that genuine experiments of a definite nature are to be carried out, and that such experiments cannot be made with an A.A. licence. An application form, obtainable from the same address as the A.A. licence, will have to be completed, answering certain questions relating to technical qualifications, nationality and character.

To quote the vital paragraphs in the regulations :

“ Applicants must satisfy the Postmaster-General as to their qualification and intention to conduct experiments of scientific value or public utility. If scientific investigation is intended they should be certified as competent investigators by

a Government Department or some recognized scientific body. Authority to use wireless sending apparatus, even with an artificial aerial can be granted *only if the nature of the* proposed experiments and other circumstances warrant that course."

If the application is favourably considered, a morse test has to be passed, when the applicant has to transmit and receive twelve words per minute, for a period of five minutes.

A Full Licence costs 30s. for the first year, and £1 for every succeeding year, that is an initial fee of 10s. for the licensing and an annual fee of £1, payable in advance. These charges only cover stations operating on a power up to 10 watts, which is the maximum power for new transmitters in the amateur class. There are certain specifications governing the apparatus, its type and operation, but these will be dealt with in later chapters when designs are being considered.

Cost.—Transmitting apparatus can cost anything from a few pounds to sums far beyond the average constructor's wildest dreams, but, it need not be half so costly as many people think; in fact, it is possible to reckon the cost of a simple low-power transmitter in shillings, so there is no need to fear that expenditure will be too high to allow the necessary gear to be made or secured.

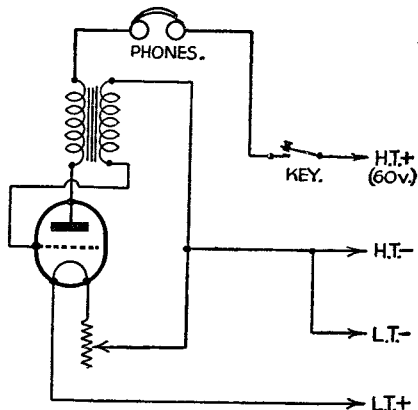

Fig. 1.—A Simple L.F. Oscillator for Morse Code Practice.

Quite a number of enthusiasts have been under the impression that "mains" operation is essential, and, as they have not had an electricity supply in their district, they had dropped all idea of transmitting. Therefore battery as well as mains-operated apparatus is dealt with, as quite a good range can be obtained without excessive H.T. consumption.

Morse Code.—Most short-wave enthusiasts have a slight knowledge of the morse code; before, however, one can

become the owner of a fully licensed transmitting station, it is absolutely essential to master the code both as regards sending and reading. Bearing in mind that it will take, at least, two to three months of diligent practice to become reasonably proficient, and, as a sound knowledge of morse is essential for the licensing tests, no time should be lost in making up the simple L.F. oscillator (Fig. 1) and getting down to practice.

The complete International morse code is set out on page 132, and it will be seen that the letters of the alphabet, numbers, punctuations and abbreviations are formed by various arrangements of "dots" and "dashes."

Always think of a "dot" as "dit," and a "dash" as "dah," and adopt the habit of saying "dit dah" for A; "dah dit dit dit" for B, and so on, and you will, eventually, recognize letters by their resultant sound, and not so much by so many "dots or dashes."

Note that several letters consist only of "dots," while others are formed by "dashes," for example, E, I, S and H use only "dots," and T, M and O "dashes."

There are several letters which have opposites. A is the reverse of N, B the reverse of V and so forth, and it will be found that such little aids to the memory all help in mastering the complete code.

Pay particular attention to the length of "dits," "dahs" and the time between each letter and word. A "dah" is equal to three "dits"; the time between each letter should be the same as that taken by one "dit," while five "dits" represents the space between each word. •

Don't on any account, adopt a sloppy or careless style of sending, as you will find it very difficult to get out of the habit when you reach the transmitting stage, and other amateurs will report that your signals are not readable.

CHAPTER II

FUNDAMENTAL PRINCIPLES

BEFORE proceeding with the practical side of the work, it is important to discuss fundamentals.

Electricity.—Electricity is the vital factor of wireless transmissions. Without it, broadcasting and the radiating of wireless signals, in any form, would be impossible.

It is not made or generated, as in the case of, say, gas, glass or soap. It is present in all "matter," but, in a latent or inactive form, and it is not until it is made to get a "move on," that it indicates its presence by one or more of its many applications.

All "matter" is formed by a mixture of what scientists call "*electrons*" and "*protons*." An "electron" is the smallest possible quantity of "*negative electricity*."

If, by some means or another, the electrons can be made to move, it is said that an electric current has been set up; or, if you like to put it another way, an electric current is nothing more than a movement of electrons which are present in all "matter." It is necessary, of course, to provide some means to create the stress or strain in the matter to cause the movement of electrons. Dynamos and batteries are two of the most common means, but they do not generate or make the electricity.

Unit of Measurement.—As the stress or strain can be a variable quantity, some Unit of measurement had to be adopted, so it is usual to refer to it as the "electro-motive-force," written E.M.F. or just plain E, and use the name "volt" for the units of force or pressure.

Direct Current.—Every constructor is familiar with the terms A.C. and D.C., which are abbreviations of "alternating current" and "direct current," both of which are used in radio and domestic work.

If conditions are so arranged, that the electrons move in *one direction only* (Fig. 2), like a long procession, then it is said that a "direct current" is flowing.

Alternating Current.—If, however, the source creating the stress is such that the movement of the electrons is *not* continuously in one direction, but backwards and forwards (Fig. 3)

the reversal of direction taking place frequently, then the resultant current is "*alternating*," and the number of times the reversal or alternations take place per second is known as the "*periodicity*" or "*frequency*."

It is essential that these brief details are remembered, as they play an important part in wireless, and they will be elaborated on from time to time.

Conductors.—Electricity has to be provided with a path to allow it to reach the point to which it is to be applied. Such paths are called conductors, and they are usually formed from metal, although certain liquids and gaseous substances will also serve.

Some materials allow the electricity to flow without any appreciable hindrance, while others will offer sufficient opposition to stop the flow. The first types are good conductors, the others, if no current flows, are known as "*insulators*."



Figs. 2 and 3.—Diagrams showing the movement of electrons in a D.C. and an A.C. circuit.

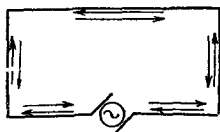

Resistance.—The opposition to D.C. is always called "*resistance*," and denoted by the letter R. A perfect insulator has, of course, infinite resistance. The Unit of measurement is the "*Ohm*."

The resistance of a conductor depends on its size, i.e., its cross-sectional area, the material of which it is formed, and its length. The formula can be written: $R = \rho \frac{L}{A}$ where ρ is a constant depending on the material, and known as the "*specific resistance*," L, the length of the conductor, and A, the cross-sectional area. L and A must be in the same units of measurement. The "*specific resistance*" of a material will be found in most electrical text-books. The accompanying table shows the values of the more common metals.

Specific Resistances in Microhms—

Copper (annealed) : 1.561.

Copper (hard drawn) : 1.647.

Aluminium (annealed) : 2.665.

„ (hard drawn) : 3.160.

Iron (annealed) : 9.065.

Zinc : 5.751.

Ohm's Law.—This Law concerns the relation between the resistance (R) of a circuit, the applied E.M.F. (E) and the current (I) which will be set up. The relation can be written :

$$I = \frac{E}{R} \text{ or } E = I \times R \text{ or } R = \frac{E}{I}$$

where I is in Amperes (the Unit of Current), E in Volts and R in Ohms. If the above is memorized as $\frac{E}{I \times R}$ it is always very easy to determine one unknown quantity. For example, if the item under consideration is covered, the remaining formula is correct for calculating the unknown value.

It must be remembered that the above law only applies to direct current.



Figs. 4 and 5.—The difference between series and parallel connections.

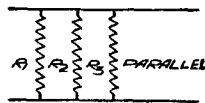

Resistances in "series," as in Fig. 4 and in "parallel" as in Fig. 5, are quite usual in wireless circuits, therefore, it is advisable to be quite clear on how to determine the resultant resistance.

When they are in series, $R = R.1 + R.2 + R.3 + R.4$, etc., but when they are in parallel, the calculation is a little more complicated.

$$R = \frac{I}{\frac{I}{R.1} + \frac{I}{R.2} + \frac{I}{R.3} + \frac{I}{R.4}, \text{ etc.}}$$

Power (Watts).—When a current flows in a circuit possessing resistance, a certain amount of power is lost through being dissipated in the form of heat. It is possible to calculate the power or wattage from the formula $W = I \times E$, but from Ohm's Law it is known that $E = I \times R$, therefore, it can be re-written : $W = (I \times I) \times R$, or more correctly :

$$W = I^2 \times R$$

By further substitution, it will be seen that still another method of expressing it can be obtained, namely :

$$W = \frac{E \times E}{R} \text{ or } \frac{E^2}{R}$$

Later on, it will be a question of considering or calculating the input and output of valves, and as such quantities are usually

measured in watts, readers should get familiar with the above methods.

Periods and Frequencies.—It is usual to speak of a “period,” during which the current starts, reverses and returns to starting point again, as a “cycle,” i.e., cycle of operations, and the average frequency of commercial electricity supplies is 50 cycles per second. With wireless, however, the frequencies of the alternating currents can be anything between 30 and several millions c.p.s. ; in fact, the figures become so large that the terms “kilocycle” and “megacycle” are used. Kilo meaning 1,000, and Mega 1,000,000. For example, a wavelength of 1,500 metres is equal to 200,000 cycles or 200 kilocycles per second, while a wavelength on the short-wave band of, say, 30 metres, has a frequency of 10,000,000 cycles which is equal to 10 megacycles.

Those frequencies which correspond to the frequency of sounds audible to the human ear, are usually referred to as “low-frequencies,” while those outside the range of hearing are known as “high or radio frequencies.”

The low-frequency range is from 30 cycles to 10,000 cycles per second, approximately, although it is not always possible to reproduce the entire range, owing to other limiting factors. When a current is alternating at the frequencies met with in wireless work, it produces certain effects which have to receive special consideration.

With D.C. it is quite an easy matter to determine the behaviour of a current in a circuit, but, in the case of A.C. it is not just a question of the material and size of the conductor, especially where high-frequencies are concerned.

From the formula for D.C. resistance it can be seen that the current is concerned with the whole conductor, whereas, with A.C. currents, above the low-frequency range, they tend to travel on the surface of the conductor, producing what is known as the “skin effect” which produces further opposition to the current flow. The higher the frequency, the more pronounced the effect, therefore, it is usual to use conductors offering large surface areas, often hollow, like copper tubing, for coils carrying the higher, or radio frequencies.

Eddy Currents.—When a conductor is carrying a current, a magnetic field is produced around it, and if the current is alternating, then the magnetic field will also be alternating.

Now, if a metal object is within this alternating magnetic field, currents will be *induced* in it, such currents being called “eddy currents.”

CHAPTER III

ABOUT VALVES

PROVIDING the formulæ given in the previous chapter have been studied, the question of the valve in relation to transmitting can be considered.

It must be appreciated that the valve plays a vital part in the design and construction of transmitting gear, therefore, it is essential to have a reasonable knowledge of its operation.

Let us consider the most simple type of valve, namely the "diode" which consists of *two* elements, housed in the familiar glass bulb common to practically all wireless valves.

One element is known as the "plate or anode," and the other is the filament or, if mains-operated, the "cathode," and they are shown diagrammatically, in Fig. 6.

If the filament is heated by the battery F, shown in Fig. 7, electrons will be emitted into the space enclosed by the glass bulb, but if another battery is connected, in the manner of H, as in Fig. 8, so that the "plate" P is *positive* with respect to the filament, then the milliammeter M will indicate current flowing, showing that the electrons emitted from the filament are rushing across the space to the "plate," and round through the circuit, back to their starting point, forming a continuous flow or current.

Supposing, instead of a battery, a source of *alternating* current is placed across the filament and plate, thus causing the plate to be alternately positive and negative, it will be found that when the plate is *negative*, no electrons will flow across to it or, in other words, no current flow will be indicated, but, during every *positive* half-cycle of the alternating current, the electron movement will take place, and a current will flow in the circuit. From this it will be seen that the valve only allows current to flow in one direction, and that it actually "rectifies" the alternating current, leaving, so to speak, a pulsating continuous or direct current. One common application of the "diode" is the rectifying of A.C. supplies in a mains-operated receiver.

Fortunately, however, the diode will rectify alternating currents having very high frequencies, as well as the usual 50 cycles of electricity supplies, therefore, it can be used as a

“detector” or “rectifier” of the radio frequencies in a wireless receiver.

The Triode.—If Fig. 9 is examined, it will be seen that a third element has been added to the diode, converting it to what is known as a “triode,” which has different characteristics and greater applications than the diode.

The arrangement of the elements or electrodes is shown in Fig. 10, G being the grid, which is literally a grid formed by a fine wire wound round one or more rigid supports; F the filament, located inside the grid, and P the plate surrounding the grid. The “mesh” of the grid, and its position in relation to the other elements play a most important part in valve

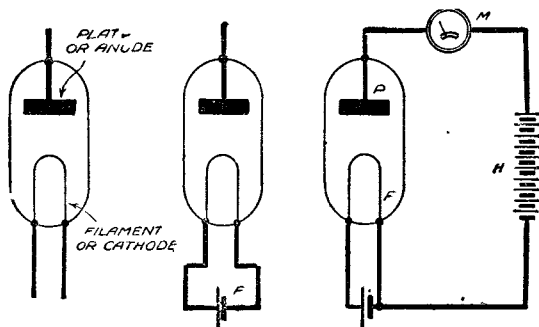

Figs. 6, 7 and 8.—Diagrams showing the diode valve and the method of applying cathode and anode supplies.

design, and construction, as they directly affect the characteristics of the valve. If the grid is connected to the filament, Fig. 11, and the circuits completed with the batteries F and H, a current will be indicated by the milliammeter, showing that the electrons are passing through the “grid” to the plate.

Now let us take the matter a stage further, and re-draw the circuit as Fig. 12, which will be recognized as a “resistance coupled” L.F. amplifier.

The battery G.B. is so arranged that the grid can be made negative with respect to the filament.

It will now be found that when the grid is made more negative by increasing the value of G.B. (grid bias) the “space” round the grid becomes more negative, and the electron flow is hindered, with the result that less electrons will get across to the plate and, therefore, less current will flow in the plate

circuit. Those not familiar with valve operation should carry out these simple experiments, and prove these statements.

Now supposing across the points "g" and "e" (dotted lines, Fig. 12), we apply an "alternating" voltage, equivalent to a signal coming from V_1 , the effect will be to make the grid more or less negative, in relation to its *normal mean value*, i.e. the bias. This "more or less negative" arrangement, may not be too clear. One might say, why negative—what about the positive cycles of the alternating current (signal)? Think of it thus. The grid *is* negative—in this case—because of the applied grid bias, so, the negative half-cycles make it *more* negative, while the *positive* half-cycles make it *less* negative.

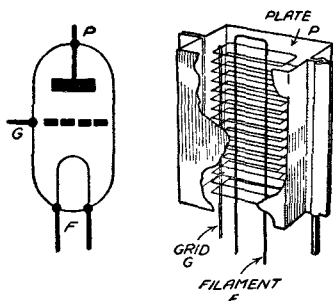

Figs. 9 and 10.—Theoretical and practical assembly of the triode valve.

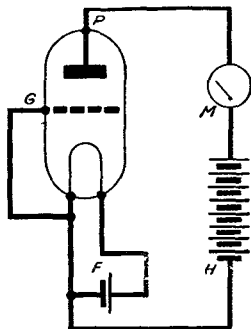

Fig. 11.—The complete circuit of a triode to show the flow of current.

The variation of the grid voltage will have its effect on the plate current by causing it to fluctuate about its "mean" value, according to reason given for Fig. 12.

Voltage Drop.—Turn now, to the plate circuit of V_2 , where R is a resistance or impedance (coil) forming what is known as the "load." Reverting to Ohm's Law, it will be understood that a resistance in a circuit can cause a "voltage drop" according to the current flowing.

In the case in question, the variation in the plate current will cause a variation in the voltage dropped across the resistance R and, now, the next two facts are *very important*, assuming the valve to be operating correctly, the voltage variations will be identical to the grid variations, but they will be larger or, in other words, they will be *amplified*, showing that

the three-element valve differs from the two-element type inasmuch that it not only acts as a rectifier of alternating current but it also acts as an "amplifier."

Certain valves are better than others as amplifiers, and as it is necessary to have some term to denote their capabilities in that respect, we speak of the "amplification factor" of a valve, and use the term "Mu" and the sign μ to denote it.

It is possible to calculate the "amplification factor," and it is advisable for all experimenters to be familiar with the procedure, so that they can check their valves from time to time. As it relates to actual magnification, the factor can be expressed as the ratio between the change in plate voltage necessary to produce a given change in plate current; and the change in *grid* voltage necessary to produce the *same* change in current. The formula can be written:

$$\frac{\text{Change in plate volts}}{\text{Change in grid volts}}$$

The plate current being constant.

There is no unit of measurement, as Mu or μ is simply a number. The Mu of a valve is only one of its characteristics and it is necessary to consider the "mutual conductance or slope" and the "impedance."

Mutual Conductance.—The "mutual conductance" denoted by the letter "g" is an indication of the "goodness" of the valve, as it is the ratio between the *change in anode current*

and the *change in grid volts* the plate volts remaining *constant*. It can be written :

$$\frac{\text{Change in plate current}}{\text{Change in grid volts}}$$

The unit of measurement being

in milliamperes (plate current) per volt (on grid). The "impedance" or, sometimes quoted as "A.C. resistance" of a

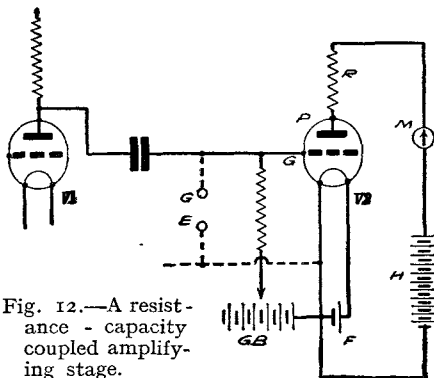

Fig. 12.—A resistance-capacity coupled amplifying stage.

valve is another ratio, but this time concerned only with the plate circuit, the *grid* being maintained as a *constant voltage*. It is denoted by the letters "Ro," the unit being ohms.

Characteristic Curves.—To understand this more fully, the *characteristic curve* must be referred to, and it is really essential that every constructor should know how to read such curves and how they are formed.

In Fig. 13, it will be seen that a vertical line has been marked off in milliamperes, to represent the anode current flow, while the horizontal base is marked off in volts to indicate the H.T. applied to the anode.

If the H.T. is increased, from zero, by regular steps of, say, 10 volts, it will be found that the current also increases, and the curve is obtained by plotting the H.T. voltage against the anode current. For example, with 22 volts the current is 1 mA. so a dot is made on the vertical line of the 22 volt mark *opposite* the 1 mA. mark on the anode current scale. This procedure is repeated at 40, 60, 80 volts until the maximum anode voltage for the valve concerned is reached, then a line is drawn through all the points plotted, the result being the curve indicated by the line "a" "b."

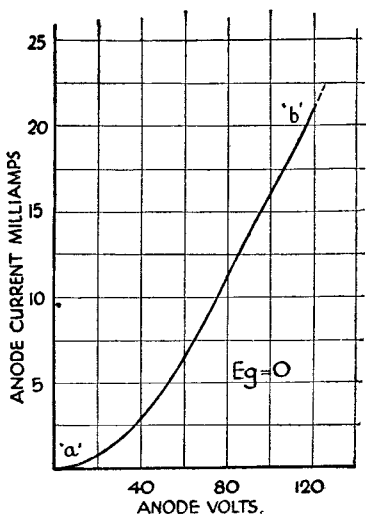

Fig. 13.—Anode current/anode volts curve.

E_g = grid volts, in this case zero.

From this curve it is possible to see what anode current will flow at any particular value of H.T. voltage, when the grid is at zero potential, i.e., when it is connected to the negative side of the filament and no additional bias voltage applied. Most valve makers publish several curves of this type. One being taken under the above conditions, and others with the grid receiving different values of bias.

A better idea can be obtained from what is known as the

Grid Volts/Anode Current curve, which is shown in Fig. 14, the curve being formed by plotting Grid Volts (bias) against Anode Current. The effect of positive and negative bias should be noted; the length of the straight portion, and the shape of the bend at the bottom of the curve are important, while the *cut-off point*, i.e. the bias value for zero anode current, must also be appreciated. If a signal or source of alternating voltage is now applied across the grid and filament *but in series* with sufficient negative bias to bring the operating

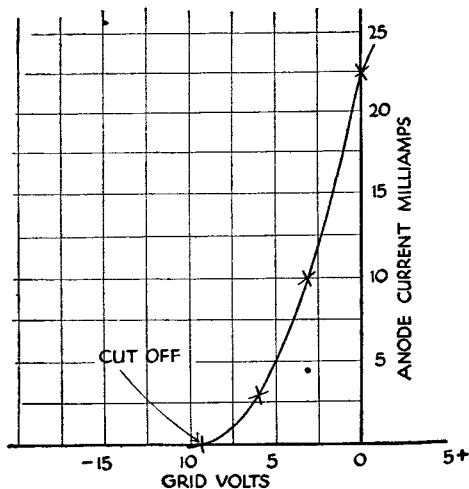

Fig. 14.—Grid volts/anode current curve.

point near the centre of the straight portion, the grid potential will rise and fall about its mean of normal value and the effect of this will be to cause a similar but *amplified variation* about the mean anode current. A study of the curve shown in Fig. 15 will explain why an amplified variation is obtained.

The size or amplitude of the input signal curve should be compared with that of the anode current variation curve, "g" and "a" respectively.

To make the reason why it is essential to work on the straight portion of the curve—when considering amplification—more clear, let us see the effect of applying the signal at the bottom of the curve.

The input signal is represented by the curve "d" and the output by "e", and it is not difficult to see, that, through operating on the bottom bend of the curve, the positive half of the signal has far greater effect on the anode current than the negative half or, in other words, the variation about the mean anode current is no longer a faithful reproduction of the signal, it is *distorted*.

Mean Values.—The beginner must not be confused with the expression “mean” value. Think of it in the following way.

To secure the operating conditions given above, it is necessary to use a certain value of grid bias; well, that can be thought of as the normal or mean value. The incoming signal, either increases or decreases it. With the anode circuit, it can be seen from the curves that a steady current is always flowing—that is the mean, in that case, and any variation takes place above or below that mean value. The points “m.g.” and “m.a.” indicate the respective mean values.

Simple Test Panel.—

It is not a difficult matter to make a simple test panel to check this characteristic of a valve. The arrangement shown in Fig. 16 is all that is required, the procedure being as follows: With the plug P in socket A and all switches, except S₁, open, adjust the H.T. supply to 100 volts. The value being checked by closing S₃. The anode current shown by the milliammeter M is noted, then the H.T. is increased by, say, 20 volts, and the fresh reading of M observed.

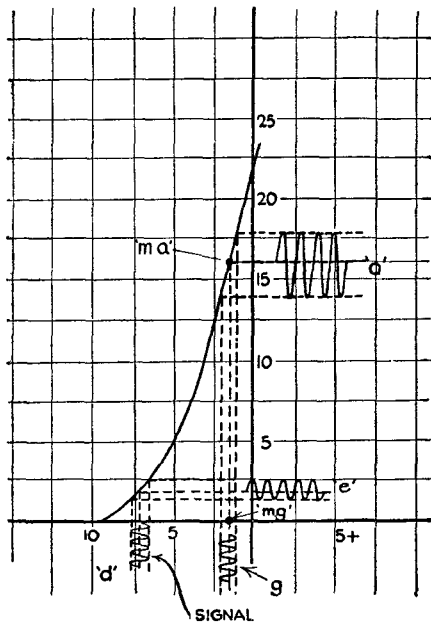

Fig. 15.—Characteristic curve showing the varying amplitude of the input signal.

Opening S₁ for a moment, the plug P is then put into socket B and, with S₁ closed again, the bias is adjusted until the reading of M is reduced to its original value. The bias voltage necessary, being read by the voltmeter V_g.

This gives the change in plate voltage, in this case 20 volts

and the change in grid voltage, to bring about the same change in plate current, the amplification factor being :

$$\frac{\text{Change in Plate voltage}}{\text{Change in Grid voltage}}$$

As this characteristic is very closely related to others, equally as important, the beginner will do well to get familiar with the method of determining it himself. In fact, the simple test panel mentioned, will prove valuable during all experimental work.

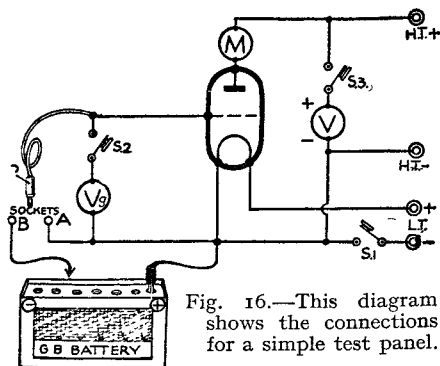

Fig. 16.—This diagram shows the connections for a simple test panel.

Unfortunately, characteristic curves do not convey all the information required when one is designing a receiver, amplifier or component.

They are known as *static curves*; and do not, for example, give any indication of the valve's performance during actual operating conditions. It will be remembered

that they were plotted by taking several readings at different D.C. values, i.e. grid or anode volts.

What is really required are curves showing the characteristics of a valve under operating conditions—when a *load* is in its anode circuit—and when its anode current and anode voltage are dependent on the value of the load, and in turn, on the grid voltage.

All these details are most intimately related to each other and, what is even more important, the efficiency of the work of the valve is governed by the ultimate selection of the operating values.

Most constructors have had actual proof of this, especially with L.F. amplifiers, when something has been wrong with the setting of the bias or H.T., or when trying various components or loud speakers.

Load Effect.—It is essential that the load effect be understood clearly, therefore, once again you must refer to one of the static curves and refresh your memory about Ohm's Law.

The curve "a" in Fig. 17 will be recognized as a simple grid volt/anode current curve, but those marked "b" will, no doubt, be new to many readers. They represent the effect on the anode current, of various loads in the anode circuit, the H.T. being constant. It will be noted that the curves ("b") become less steep as their resistance is increased. In other words, less anode current flows, the reason for this being connected with Ohm's Law as mentioned below.

From the Law it will be remembered that I (current) equals E (voltage) divided by R (the resistance of the circuit), therefore, rearranging the formula, we get E equals I multiplied by R . From this, it will be obvious that the voltage dropped across a resistance depends not only on the value of the resistance but also on the current flowing.

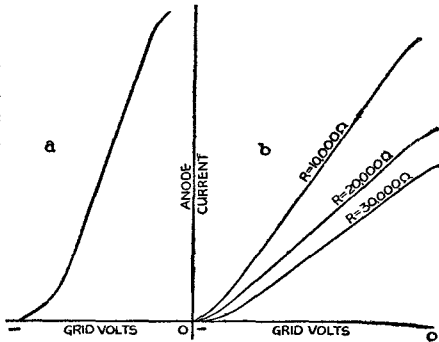

Fig. 17.—The standard grid-volts/anode-current curve, and the effect of varying loads shown graphically.

Referring to the curves "b." As the bias is increased, less anode current flows; likewise there is less voltage drop across the resistance but, as the bias is reduced, the anode current increases—the voltage drop becomes greater and, therefore, less effective H.T. reaches the anode, the result being, a flattening out of the curve compared to those of "a."

Grid Voltage Values.—It is now necessary to draw a series of fresh curves but with these, it is intended to plot anode current against anode voltage, at different *fixed* values of the grid bias.

The curves thus formed are shown in Fig. 18. In appearance, they are very similar to the simple curves of "a", but, by plotting a series or *family* of them for different values of grid voltage, it is possible to determine several important items vitally connected with the efficient operation of the valve concerned. The theoretical circuit of the valve arrangement is shown in Fig. 19.

It is usual for the H.T. supply E_b to be sufficient to

supply the anode with its specified operating voltage at the normal anode current. For example, if the valve is rated at about 200 volts (maximum) on the anode, its normal operating current is, say, 20 mA., and the load is equivalent to 5,000 ohms, then the voltage dropped across the load will be 5,000 multiplied by $\cdot 02$ amperes (20 mA.), which is equal to 100 volts. This, therefore, necessitates E_b being capable of supplying a voltage of 200 (required by the anode) plus 100 dropped across the load or, in other words, 300 volts.

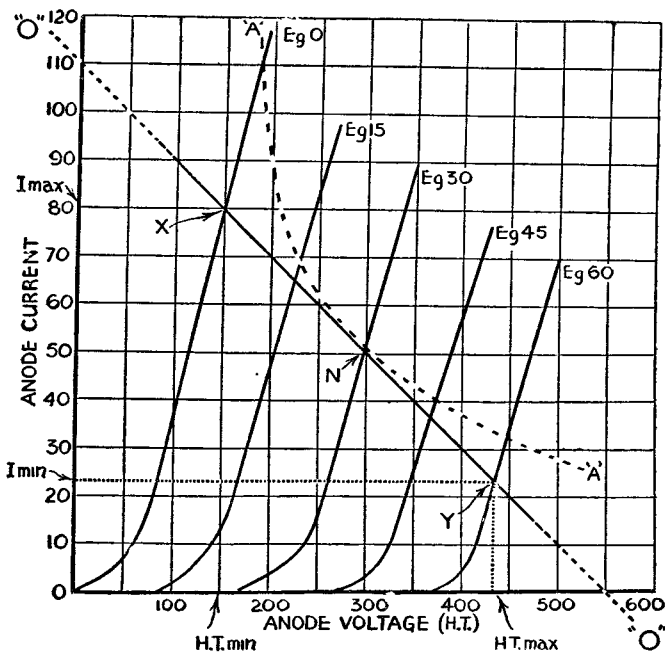

Fig. 18.—Dynamic curve, showing load line, dissipation, and other important working data.

The bias values can be taken through the voltage range applicable to the valve under consideration, the limits being, of course, set by the cut-off point, i.e. no anode current, and the saturation point.

Maximum Anode Dissipation.—The next thing to consider is the maximum anode dissipation of the valve concerned, as

it is essential for the operating conditions to be kept within that limit, otherwise the life of the valve will be reduced.

Assuming that the anode dissipation is 12 watts, it should be noted that that figure represents anode dissipation, and not A.C. or undistorted output, which is a very different item. The anode dissipation is the product of the applied H.T., and the D.C. anode current for that H.T. value. For example, if 250 volts is the maximum anode voltage suggested by the makers, it will be safe to allow an anode current of 48 mA. to flow, 250 multiplied by $\cdot 048$ (48 mA.) equals 12 watts.

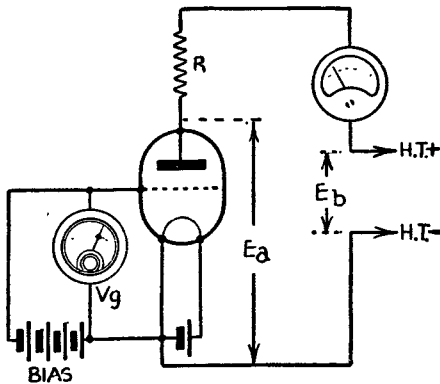

Fig. 19.—Circuit arrangement for taking dynamic curves or other valve data.

To obtain a graphical indication of the permissible dissipation at the various grid and anode voltages of the curves shown, the dotted curve A, A is produced. Its position on any one of the anode volts/anode current curves is determined by the product of the anode volts multiplied by the anode current which, of course, as the current is in milliamps, must be divided by 1,000, the normal operating current for the grid voltages concerned being obtained from the makers specification, or the grid volts/anode current curve.

Load Line.—Now that the limits, so to speak, are set, the next thing is to plot the curve O O, known as the *load line*, which allows the actual undistorted output to be calculated together with the value of load which will give maximum efficiency.

The point N, which represents the normal operating point of the valve, is used for one setting of the load line, but, as the degree of slope is of some importance, it is necessary for another point to be fixed also, therefore, it is quite usual to determine the point of *minimum* H.T. volts, and set it off on the zero grid volt curve.

The value of minimum H.T. can be calculated from the impedance of the valve and the normal operating anode current, in the following manner.

Assuming that the ideal load is equal to twice the impedance of the valve—when considering triodes—the minimum H.T. will be equal to that load multiplied by the normal anode current divided by one thousand (if the anode current is in milliamperes).

Having determined the H.T. value, a vertical line is then projected from that value until it intersects the zero grid volt curve, the point of intersection X forming the second bearing, so to speak, for the load line.

The line can then be drawn through X and N and continued until it cuts the curve which represents *twice* the *normal* grid bias voltage, point Y. If, from that point, a line is dropped to the H.T. volt base, it will give the value of the maximum H.T., while the *minimum* anode can be read off the vertical current scale by projecting the point Y to the left. If the load was in the nature of a pure resistance, i.e. no inductance, the line O O would be perfectly straight, and, if it was continued until it cut the anode current scale and the H.T. base, the H.T. voltage divided by the anode current—at the points of intersection—will give the impedance of the load. If a signal is applied to the grid having a peak voltage swing of, say, 15 volts about the operating point N, it must be understood that the positive peak will be 30 *minus* 15, i.e. 15 volts, while the peak negative swing will be 30 *plus* 15 or 45 volts. If the values of H.T. and anode current are taken for those grid voltages, it will be seen that they are $E_g - 15 = 65$ mA. at 220 v. and $E_g - 45 = 37$ mA. at 370 V.H.T.

Anode Current Swing.—From these changes, it is possible to determine the H.T. and anode current swing for the signal in question, by the simple arrangement shown below.

H.T. voltage swing equals $\frac{370 - 220}{2} = 75$. It should be noted that the division by 2 is necessary as the changes have been produced by the positive and negative swing about the

normal operating point or, in other words, an alternating value is always obtained about its zero point.

The anode current swing is obtained in the same way, namely, it equals $\frac{65-37}{2}=14$.

One item which must be noted from the above example is, that the grid is 15 volts positive at the peak of that half cycle; a very undesirable state of affairs so far as L.F. amplification is concerned. It is, therefore, very essential for the valve to be fully loaded and, quoting the above case again, the maximum swing about N should be 30 volts in which case the grid voltage will not go beyond zero in the positive position.

Under these conditions the H.T. voltage and anode current swing would be:—Eg O=80 mA. at 150 volts H.T. and, Eg 60=23 mA. at 430 volts H.T. the anode current swing being $\frac{80-24}{2}=28$ at the H.T. swing= $\frac{430-150}{2}=140$.

From these values, the output of the valve can be calculated by applying the formula: Output Watts=(I max.—I min.) multiplied by (H.T. max.—H.T. min.), the result being divided by 8.

To avoid confusion, I *max.* equals the higher value of the anode current, while I *min.* equals the minimum or lower value. The expressions concerning H.T. max. and min. apply in the same manner.

Second Harmonic Distortion.—It will be appreciated that if distortion (harmonic) is allowed, it will be possible to obtain a greater output for a given valve, therefore, it is necessary to set some limit to the amount of distortion permissible, when carrying out output calculations. With triodes, it has been found that the ear can tolerate 5 per cent second harmonic distortion without any disagreeable effects, so it is usual to allow that amount and arrange matters accordingly. Without going into minute details, it can be taken that 5 per cent second harmonic distortion is obtained when the distance N X is $\frac{11}{9}$ of the distance N Y.

Regarding the slope of the load line and its relation to the value of the external load, the desirable resistance R₁ can be determined from $R_1 = \frac{H.T. \text{ max.} - H.T. \text{ min.}}{I \text{ max.} - I \text{ min.}}$ (in ohms).

In all the above calculations, it should be noted that I is in amperes and H.T. in volts.

CHAPTER IV

THE VALVE AS RECTIFIER AND OSCILLATOR

BEFORE one can consider using alternating current supplies for the purpose of providing the necessary high-tension for a receiver or transmitter, it is essential to arrange some means whereby the alternating current can be "rectified" so that a steady current, flowing in one direction only—*direct current*—is obtained.

The process is known as "rectification," and in this chapter it refers to alternating currents of low frequency—the standard frequency of commercial supplies in this country being 50 cycles per second—and not, as in the case of rectification or detection in a wireless receiver, to alternating currents of radio or high frequency.

When dealing with batteries or D.C. supplies, the potential can be considered to be steady, while the polarity is always constant, one side of the circuit being negative and the other side positive. With A.C., however, the state of affairs is very different, as the polarity alternates between a positive and negative maximum value.

It is possible to represent the difference between the two supplies graphically, and "x", Fig. 20, indicates the wave form of a direct current, while "y" shows that produced by an alternating supply, the change in polarity being clearly indicated. The distance between the two points "a" and "b" represents a complete cycle, during which the current passes from zero to positive maximum, back to zero and on to negative maximum, finally completing the cycle by returning to zero. This cycle is repeated very frequently, and it is the number of times per second that it takes place which determines the periodicity or frequency of the current.

If the two curves are given a little consideration, it will be appreciated that to obtain the required results the alternating current has to be stopped from flowing in alternate directions, i.e., above and below the zero line; therefore, various methods have been devised to do this, but in this article we are only concerned with the thermionic valve as a rectifier.

The Valve Rectifier.—The original thermionic valve (Fleming) employed two electrodes only (diode valve), a filament and

an anode, as indicated in Fig. 21. For its operation it depended on the filament, when heated, emitting electrons which passed across the intervening space to the anode, providing the anode was maintained at a positive potential,

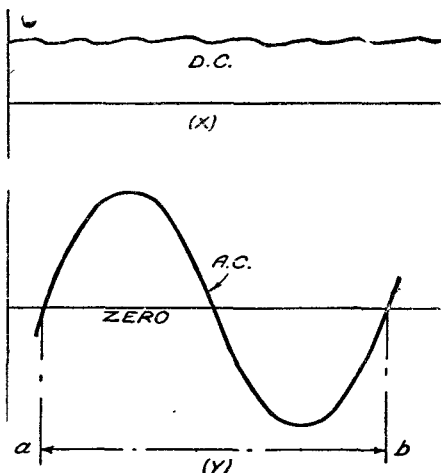

Fig. 20.—Graphical representation of a D.C. and A.C. supply.

with respect to the filament. The flow of electrons constitutes an electric current, and the milliammeter M will indicate its presence when the required operating conditions are in force.

The rectifying valve of to-day is fundamentally the same, though, of course, vast improvements have been made as regards design, construction and efficiency.

The modern rectifying valve can be of the directly or indirectly heated type ;

it can be fitted with one or two anodes for half or full-wave rectification, while larger electrodes are employed to allow the necessary output and life to be obtained.

One of the main considerations in design is the reduction of voltage drop across the valve, perfect insulation, and a filament which is capable of giving a generous emission without excessive loss of life. The placing of the anode in relation to the filament is very important, as the distance between them has a direct bearing on the voltage drop.

Operation.—Referring again to Fig. 21. If the battery B is replaced with a source of alternating current, it follows that the anode will be alternately positive and negative ; therefore, in view of the previous remarks concerning the Fleming valve, it also follows that current will flow only during the positive half-cycle, i.e., when the anode is positive. During the negative half-cycle, no current flow will take place, so what really happens is : a *unidirectional* current is set up, *but* it is of a *pulsating* nature due to the time between successive positive half-waves.

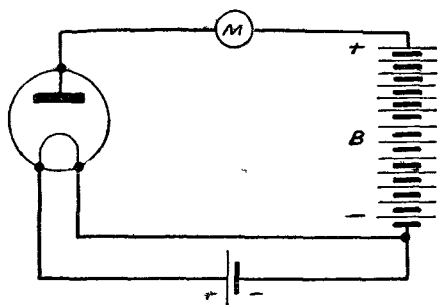

Fig. 21.—Simple or basic rectifying circuit.

half of the A.C. wave, it being the most simple method possible and it is usually known as half-wave rectification.

Full-wave Rectification.—If two half-wave rectifiers are connected, as shown in Fig. 23, it will be possible to utilize the complete A.C. cycle and obtain a greatly improved output wave form.

The source of alternating current is obtained from the mains, via the transformer T, which can be so designed that the voltage output of the secondary windings is greater or less than the actual mains supply.

The secondary S is provided with a tapping at its dead electrical centre, and

This can best be understood by examining Fig. 22, in which curve A shows the wave form of the rectified output, and it will be appreciated—by comparison with “x,” Fig. 20—that the D.C. thus produced is still far from perfect.

The system described deals with only

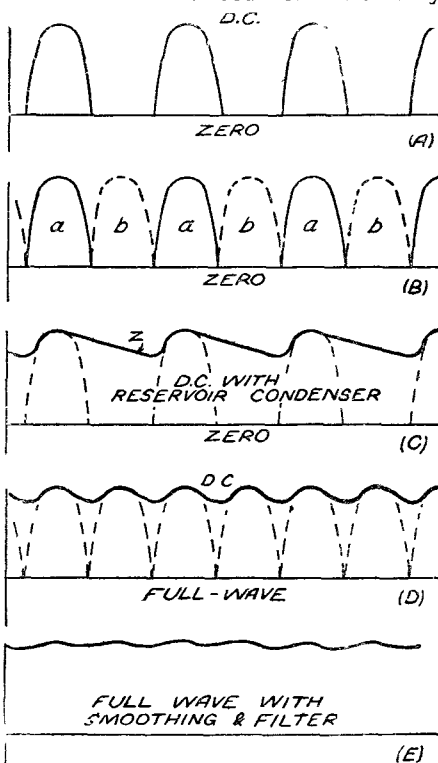

Fig. 22.—Graphical representation of the effects of rectification and smoothing of an A.C. supply.

it is essential that the voltage across "s" and "s.l." is equal to twice the voltage required by the anode of each rectifier, thus giving between "c.t." and "s" and "c.t." and "s.l." a voltage equal to that required by each valve.

When the secondary is positive at "s," current will flow through the rectifier R, but R1 will be inoperative. As soon, however, as the polarity of the secondary changes, "s.l." will become positive and the current flow will be through rectifier R1, while R will cease, as that end of the winding is then negative.

By adopting this method, and it is the one most widely used, both half-cycles of the A.C. waves are rectified, and the resultant output is considerably smoother or, in other words, the big gaps between the pulses A, Fig. 22, have been filled in, as shown by B of the same diagram, by the rectification of the additional half-wave.

It is not usual for average amateur work, to use two separate half-wave rectifying valves to obtain full-wave rectification, as full-wave rectifying valves, containing two sets of electrodes within one bulb, are standard products of the various valve manufacturers.

Smoothing.—It has been agreed that the outputs obtained so far are still far from perfect, and quite unsuitable to feed the anodes of the valves in a receiver or transmitter, therefore, some smoothing arrangements must be employed.

For simplicity's sake, consider the half-wave output first. Quite a high degree of smoothing can be obtained by simply connecting a suitable fixed condenser across the output. In fact, such an arrangement also has a marked effect on the output voltage, tending to raise the value; therefore, although the capacity is not exactly critical, it is advisable to follow the rectifier makers specification. If the condenser has too high a value, damage can be caused to the rectifier by excessive charging currents, while, on the other hand, if the capacity is too small, the condenser will discharge its load too quickly or too much before it receives the next charge, thus producing a pronounced ripple.

If the curve C (Fig. 22) is examined, the general effect of the condenser can be seen. During the positive half-cycles the condenser receives a charge which is discharged, or partially so, during the following negative half-cycles, thus, as the curve shows, filling in, so to speak, the gaps between the pulses or peaks, the part "z" being condensed voltage.

For the average amateur working voltages a capacity of 4 mfd. is quite satisfactory, but it will be found that half-wave rectification requires more smoothing than full-wave.

The unevenness of curve C is due, to a great extent, to the presence of "ripple" voltages superimposed on the direct current, and if such are allowed to remain it is highly probable that pronounced "hum" will be experienced, so a simple filter circuit has to be embodied to remove all traces of them. A good L.F. choke and another fixed condenser are all that is necessary, at least, in the majority of cases, and they are intro-

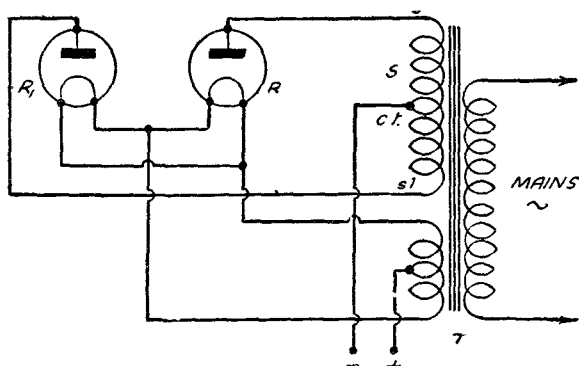

Fig. 23.—Method of using two half-wave rectifiers to obtain an improved output waveform.

duced into the circuit as shown in Fig. 24, which shows the complete full-wave rectifier arrangement.

With the output of the full-wave circuit, the condenser smoothing has an even greater effect than in the previous case, the resultant curve being shown as D (Fig. 22), where it will be seen that the output is no longer a series of heavy pulses, but a fairly steady supply.

The filter circuit is still, however, essential, and its effect can be seen by examining the curve E (Fig. 22), which represents a reasonably good D.C. supply.

The choke "Ch" Fig. 24, should have an inductance of at least 20 to 25 henries when carrying the maximum current output of the rectifier concerned, while C1 should be 4 mfd. to

6 mfd., and, for safety's sake, it is advisable to see that it is made for a "working" voltage of, say, 50 per cent higher than the rectified output.

The Valve as an Oscillator.—The first requirement of a wireless transmitter is some source or generator of oscillations, and it is of vital importance that the frequency of the oscillations can be controlled. The valve is ideal for this purpose, in fact, it may be said that it has superseded all other forms, and is the only method suitable for amateur requirements, bearing

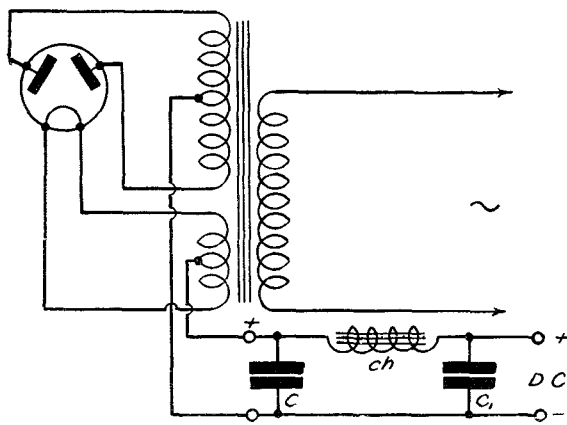

Fig. 24.—A full-wave valve rectifier circuit.

in mind regulations. Fig. 25 shows the most simple circuit, and many of the older experimenters will recognize in it, the early one-valve receiver. Across the grid filament circuit is connected the inductance L tuned by the variable condenser C . In the plate circuit is another inductance L_1 , in series with the H.T. battery, and it is so placed that it is inductively coupled to the grid circuit.

If the inductive coupling is sufficient, a certain proportion of the energy in L_1 will be fed back into the grid circuit, and if the transference of energy is great enough, oscillatory currents will be set up in the grid circuit, and a state of oscillation will be reached.

inter-electrode capacities of the valve can, to a certain extent, influence the result (capacity feed-back).

Assuming that a tapped coil, as in Fig. 26, is in use, it will be found that the degree of "grid-excitation" (feed-back) can be controlled by the position of the tap "t" on the coil L_1 . The closer the tapping point is moved towards the plate end of L_1 , so will the grid excitation increase. With an average circuit and valve, satisfactory operating conditions can be obtained with, say, .3 to .5 of the total number of turns in the plate-tap circuit.

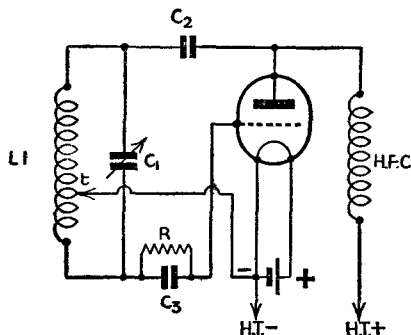

Fig. 26.—The standard Hartley circuit.

In each circuit (Figs. 26-27) the grid receives its necessary bias by means of the voltage developed across the resistance R , the condenser C_3 preventing any D.C. voltage from the filament reaching the grid. The value of C_3 is not too critical, but R should be selected according to the type of valve and the actual operating conditions. Its value is often best determined by experiment.

Colpitts Circuit.

The Colpitts circuit (Fig. 28) is an example of capacity feed-back or excitation, and it depends for its control on the capacity ratio of C_{1a} and C_{1g} , the two condensers being in series across the inductance L_1 . The smaller the capacity of C_{1g} compared to that of C_{1a} the greater will be the excitation of the grid circuit but, the total capacity must be kept constant to maintain the desired frequency.

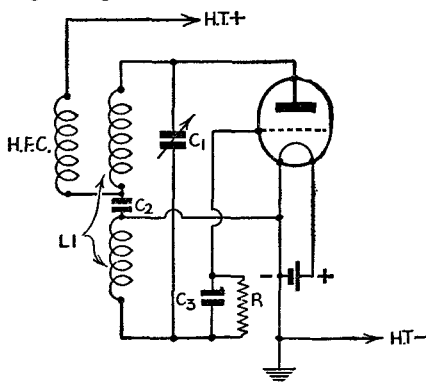

Fig. 27.—A modification of Fig. 26—known as the series-fed Hartley

The Ultraudion.—Another circuit, very similar to the Colpitts, is the Ultraudion, Fig. 29, but as it is not widely used, except for ultra-short waves, it is not necessary to discuss, in detail, its operation in this chapter.

Tuned-Plate Tuned-Grid.—This circuit, which is quite popular, is shown in Fig. 30, where it will be seen that its name is obtained from tuned circuits of the plate and L_1 grid.

It does not depend on inductive coupling between the coils L_1 and L_2 for the essential feed-back, but on the capacity existing between the grid and

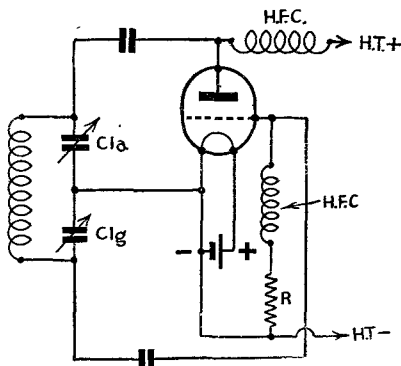

Fig. 28.—The Colpitts circuit.

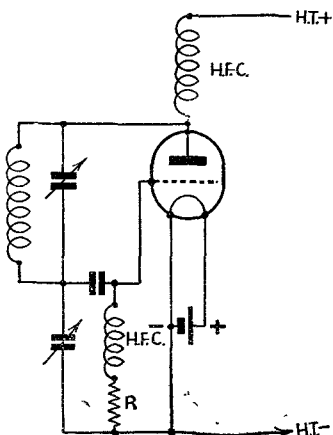

Fig. 29.—This is the Ultraudion circuit.

plate elements of the valve. A state of oscillation will be reached when both circuits are tuned to a common frequency, although maximum efficiency is only obtained when the two circuits are not "dead" in tune. The frequency of oscillations is governed—chiefly—by the characteristics of the plate circuit, the grid circuit not being so critical. The degree of excitation is governed—mainly—by the constants of the grid coil circuit, which is usually tuned to a slightly lower frequency than the plate arrangement. The tuned-plate tuned-grid or T.P.T.G. oscillator is not

too easy to adjust but, it is quite popular, as far better stability can be obtained than with other circuits of a similar type.

T.N.T. Circuit.—A variation of the above, is the T.N.T. circuit, which is shown in Fig. 31, and it should be noted that the grid

coil is no longer tuned by a variable condenser. The circuit (L1) is brought to an approximate resonant state by its self capacity, and the capacity of the valve and associated wiring. The only snag, if it can be called such, is the coil L1, but, once suitable dimensions have been determined, the circuit is quite easy to operate and tune, while it is less costly to construct than, say, the Colpitts.

The Electron-Coupled Oscillator.—If the circuit, Fig. 32, is examined carefully, it will be seen that it is nothing more than an elaboration of the fundamental inductively coupled

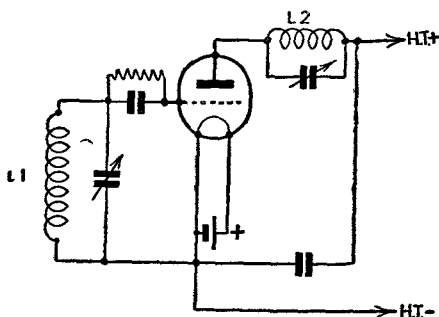

Fig. 30.—The circuit shown here is the tuned-plate tuned-grid arrangement.

have the filament tap at earth potential, but such an arrangement is not *vital*, *providing* the plate, grid and filament are at the correct *relative* potentials. In the case in consideration, the circuit is modified so that the oscillator anode is at earth potential, from an *H.F.* point of view, although, as the diagram shows, it is at a high relative *D.C.* potential. The condenser *C.a.* must have ζ capacity that will present negligible reactance to *H.F.* currents, thus maintaining the oscillator plate at earth potential.

It will be appreciated that as the plate is not allowed to vary in *H.F.* potential, the cathodes *H.F.* potential will vary, while the heater circuit can still be kept at earth potential. With a battery-operated valve, these requirements present certain difficulties, necessitating the use of suitable *H.F.* chokes, therefore, an indirectly heated mains valve has definite advantages. If the actual anode of the *S.G.* valve is given a positive potential, it will receive the electrons flowing through the screening grid *G.s.* which forms the oscillator anode. This

circuit, in fact, the Hartley oscillator can be recognized, as shown below.

The normal control grid *G.c.* becomes the oscillator grid, while the screening grid, *G.s.* serves the purpose of the plate in the Hartley circuit, and the plate proper now acts as the output. It is usual in a Hartley circuit, to

flow of electrons will actually be modulated by the oscillations generated in the Hartley portion of the circuit, therefore, the output plate circuit current will have a high-frequency component, and, if a tuned circuit is arranged in the plate circuit (T.C., Fig. 33) and tuned to the oscillator frequency, then the plate will vary in voltage at that frequency, or, in other words, the valve will be acting as an oscillator-amplifier. An oscillator of this type, providing the screening is most complete, and no external coupling takes place, is capable of giving a very high degree of stability, a most important item. Another very good

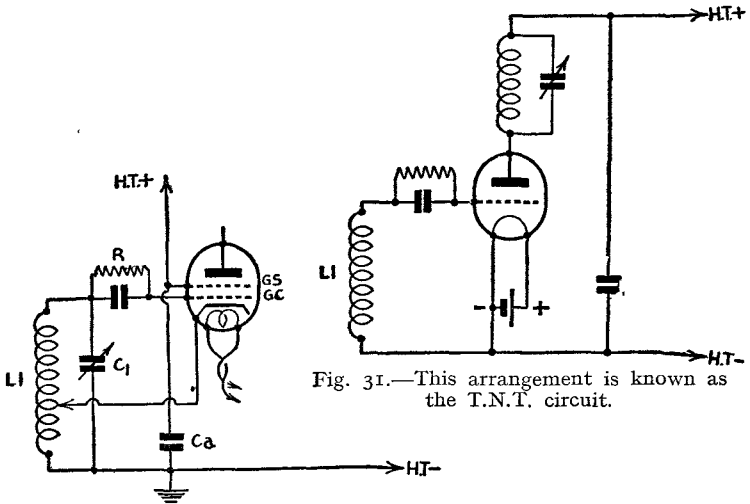

Fig. 31.—This arrangement is known as the T.N.T. circuit.

Fig. 32.—The method of coupling here gives rise to the term electron-coupled.

feature is that the electron-coupled oscillator is very efficient as regards *harmonics* of the oscillator frequency. By this is meant the output circuit (T.C.), can be tuned to two, three and four times the oscillator frequency, thus allowing similar frequencies to be transmitted, but it must be appreciated that the efficiency of the output decreases, rather rapidly, above the second harmonic. Such an operation is known as “doubling.”

Crystal-controlled Oscillators.—Most constructors are familiar with “piezo-electric” crystal pick-ups, loudspeakers and microphones, which make use of certain characteristics of crystals in the “piezo-electric” group. Quartz is the crystal

Operation.—When a crystal is vibrating or oscillating at the very high frequencies usually associated with radio-frequency circuits, a certain amount of heat is generated, due to molecular friction, and the rise in temperature can affect the frequency.

The amount of variation produced depends on the “cut” of the crystal, there being various ways of obtaining or cutting out the little slabs from the natural crystal formation. However, if certain operating points are watched, the temperature-frequency variation can almost be ignored.

The higher the radio frequency voltages across the crystal, i.e., the greater the amplitude of the vibrations, the greater will be the temperature rise, therefore, certain limiting factors are introduced if satisfactory operation is to be maintained.

A peculiar part about a quartz crystal, is that apart from the what may be called useful vibrations, there are

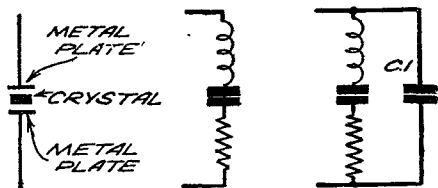

Figs. 34 to 36.—The electrical equivalent of a crystal circuit.

others which tend to produce additional heating, and stresses of a mechanical nature in the crystal's structure. If the radio-frequency voltages are great enough, it is possible for the crystal to crack up, due to the excessive stresses thus produced, so it becomes necessary to limit the power to be handled by the circuit. This is one of the points which must be noted about a crystal-controlled oscillator; it will only handle low power, say, 4 to 5 watts, therefore, it becomes necessary, with the average transmitter, to amplify the output, and the section of a transmitter which attends to that, is known as the power amplifier.

It is not always an easy matter to measure the radio-frequency voltages across the crystal, so the more simple procedure of checking the r.f. current is usually adopted. This can be done with the aid of a suitable meter or lamp in series with the earth potential side of the crystal.

The safe current depends on the type or “cut” of crystal, but for the type concerned with these articles, it should not exceed, say, 50 mA., the value being also governed by the H.T. applied, and the valve in use.

A simple triode crystal-controlled oscillator is shown in Fig. 37, where it will be noted that the usual tuned-grid arrangement, i.e. coil and condenser, has been replaced by the quartz crystal. The circuit is really a form of the T.P.T.G. mentioned previously. Other suitable circuits are shown in Figs. 38-39 from which it will be seen that pentodes appear to be more favoured than triodes. There is a very definite reason for this. Mention has been made regarding the power limitations of a crystal-controlled circuit; well, a pentode helps to overcome that snag, as less heating of the crystal takes place than with a triode for the same power input, and a greater

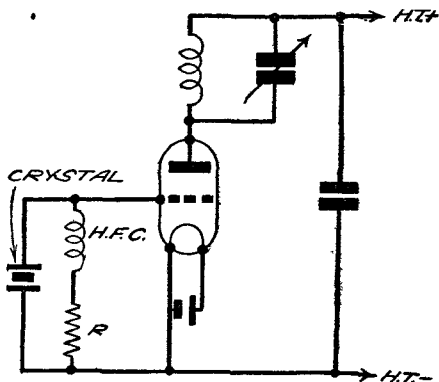

Fig. 37.—Simple triode crystal-controlled circuit.

plate voltage can be applied, due to the fact that the feedback voltage is less owing to the reduction of the plate grid capacity by the presence of the screening grid.

Frequency Doubling.—It was mentioned before when dealing with the "electron-coupled" oscillator, that the circuit possessed the advantage of being able to give a worth-

while output on frequencies which were a multiple of the fundamental and that a name or term is given to such features.

One cannot get very far with transmitting without coming across the expressions "doubling," "doubblers" and "frequency multipliers." To the uninitiated these may seem rather terrifying, but they really define that which is expressed in the previous paragraph. In other words, when a valve is so arranged that its anode output is twice the frequency of its input, it is usually referred to as a "doubler," while the process is known as "doubling." The remaining term "frequency multiplier" can be so used if so desired, as that is what really happens, but it is a term which is not widely used over here. When one speaks of "doubling" the frequency it must be appreciated that the wavelength is *halved*, or, to carry it a

stage further, if the anode output circuit is tuned to the third harmonic (multiple) of the input frequency, the wavelength will correspond to a third of that of the original. This point, while being obvious to many, often misleads the beginner.

There is nothing to prevent the anode circuit being tuned to any harmonic, except the fact that the higher the harmonic to which it is tuned the lower becomes the efficiency of the arrangement; therefore, it is more usual to make use of a chain of doublers if it is required to multiply the original frequency many times.

Little Gain.—While such an arrangement can be looked upon as a “straight amplifier” apart from actual operating conditions, it is not usual to obtain much gain from the stage, in fact, in many instances, no gain at all is obtained. For a simple “doubler,” i.e. second harmonic, the “driving” power should be two or three times as great as that required for ordinary amplification. It will be obvious, in

view of the nature of the circuit requirements, that it is not advisable to use valves in push-pull, owing to the freedom of the second harmonic content in their output; parallel arrangements are quite efficient.

Doubling.—With a simple oscillator the plate and anode circuits are coupled together, either by induction or capacity, so that sufficient energy is passed back from the anode to the grid to maintain oscillatory currents in both circuits. A common example of this is the reaction effect in a receiving circuit. When this state of oscillation is reached, the power generated is of a definite frequency—remember it is an alternating current—and the frequency of the oscillations depends on the characteristics of the grid and anode circuits, i.e., the crystal and/or the tuned circuits. If both the input (grid) and the output (anode) are tuned to the same frequency it is only natural that the oscillations in both circuits will be identical

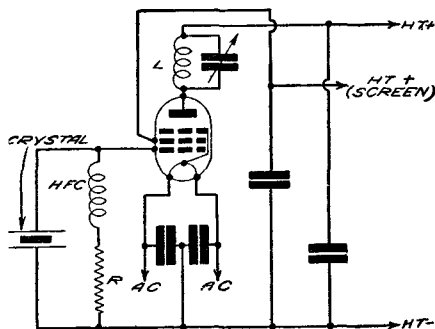

Fig. 38.—Pentode oscillator—crystal controlled.

so far as frequency is concerned, and that the anode circuit will obtain a kick or impulse every oscillation of the grid circuit. Supposing, however, the anode circuit is so arranged that it can be tuned to say, the second harmonic of the input frequency; then, instead of obtaining an impulse every cycle it will only do so every second, but providing conditions are suitable, the impulse will maintain oscillations in the output circuit at a frequency to which it is tuned, namely, in the case of the second harmonic twice that of the input. That, in a nutshell, is what happens when we speak of doubling or frequency multiplying.

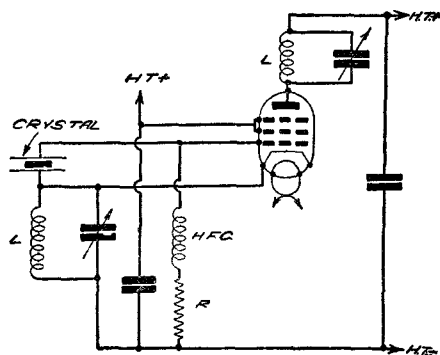

Fig. 39.—The Tritet oscillator.

certain advantages in this type of circuit, or by using a rather high-resistance grid leak, for example, the leak should have a value of three to four times the value of that specified for normal operation of the type of valve concerned.

There is one point to watch with "grid-leak" bias arrangements. If the drive or excitation of the "doubler" fails, an excessive anode current will flow, sufficient, in fact, to cause harm to the doubler valve, especially if high anode voltages are being applied. With the battery system, this risk is, of course, not present, and therefore, as both methods have certain desirable features, it is quite common for a combination of the two to be used, i.e. bias applied from a battery to keep the anode current within safe limits, and a grid leak, connected in series with the battery, to provide the extra bias needed for operating conditions during normal excitation.

To obtain a large harmonic output, it is necessary to bias the valve right down to the "cut-off" point of the anode current curve, in fact, it is quite usual to apply double the "cut-off" bias, providing the necessary drive is available. The additional bias can be provided by batteries, which have

CHAPTER VI

THE RADIO-FREQUENCY POWER AMPLIFIER

THE power amplifier in a transmitting circuit—more usually referred to as the P.A.—is primarily designed to supply power to the aerial circuit by amplifying radio or high-frequency currents previously generated. In spite of the frequency it is called upon to handle, it can hardly be considered in the same light as an ordinary H.F. amplifier, in fact, it can be more accurately likened to an L.F. power amplifier, as the power involved necessitates the use of L.F. power or pentode valves, together with sufficient grid bias to produce the correct operating conditions. Many amateurs have some difficulty with the P.A. stage. They are unable to grasp its method of operation and/or obtain the utmost efficiency, and generally all their troubles are due to the lack of appreciation of what constitutes *correct operating conditions*.

A Comparison.—The quickest way to understand a P.A. stage is to use an ordinary L.F. or output stage as the basis for the investigations. It is well known that when a valve is used as an L.F. amplifier, one is concerned only with the straight portion of the characteristic curve of the valve concerned, i.e. the grid volts/anode current curve.

This can be appreciated more readily, and the whole operation of an L.F. amplifier summed up, by reference to the curves shown in Fig. 40, where “g” represents the input and “a” the anode output. Providing the valve is operated on the straight portion, the anode output will be identical—though amplified—to the input, but if the input is such that it drives the grid too far along the negative line then distortion of the output curve is bound to be produced. It is also possible, of course, for the input to drive the grid curve into the positive section; in which case grid current will be set up, distortion introduced and the effect of the input reduced.

In case this is not too clear, it is only necessary to draw a fresh grid volt/anode current curve with “g” having greater amplitude. It will then be obvious that the operating portion will be brought down into the bend of the grid volts/anode

current curve and/or too far over towards the positive bias or zero negative bias point. In the first case the bottom of the output curve will be chopped off, while in the second, the grid will become positive and act as an anode thus producing current (grid current) in the grid circuit, a most detrimental state of affairs in L.F. amplifiers. From this it will be seen that the operating portion of the curve is limited and the actual efficiency of the arrangement low. It is these defects or limitations which necessitate operating a P.A. under rather different and, what may seem, unorthodox conditions.

The Effects of Distortion.—With the L.F. example, the distortion produced will result in the output consisting of the

Fig. 40.—Diagram illustrating the reproduction (a) of a signal (g) when working on the straight portion of the curve.

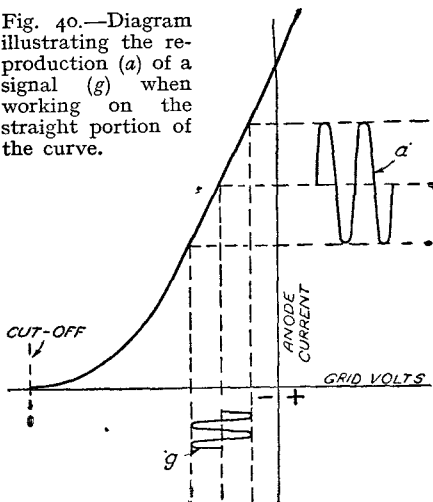

frequency of the input plus harmonics of the original frequency, and as it is possible for the average loudspeaker to reproduce the majority of these, the reproduction will not be a faithful magnification of the input. Supposing, however, that we are only concerned with one frequency and that it is possible, by using some simple arrangement in the anode circuit, to ignore any multiples

or harmonics of that frequency, then it appears that the efficiency and output of the amplifier might be increased. These are the conditions which apply to a P.A. stage. One can consider—for practical purposes—that the valve is called upon to handle one frequency only—at high frequency, of course—and that the tuned-anode circuit will select or accept the frequency of the input only and ignore all others.

This allowance in the operating limits, means that the possibility of introducing distortion *need not be* considered or, in

other words, the grid input can be increased irrespective of whether it drives the operating point on the grid volt/anode current curve down into the bottom bend. In fact, a P.A. stage is generally biased well past the "cut-off" point, as shown below.

Referring to Fig. 41, it will be seen that the grid drive and bias have been adjusted so that the operating portion swings down into the bottom bend. In the resultant anode curve is examined, it will be noted that it now represents a series of pulses, and it is these which are used to develop the power in the anode circuit.

It will be remembered that when a parallel tuned circuit is in resonance (i.e.

exactly in tune) with an applied signal, it can be considered as a high resistance load. If then, a suitable coil and condenser combination is placed in the anode circuit of the P.A. valve, it is obvious that the pulsations will set up an oscillatory voltage across the circuit, and cause an oscillating current to flow therein, when the combination

Fig. 41.—The effect of working on the bottom of the curve is shown in this diagram.

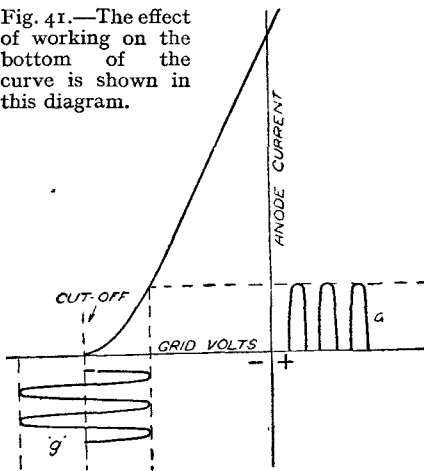

is tuned to the frequency of the input. Any harmonics which might be present will have negligible effect, as the circuit—usually referred to as the "tank" circuit—will be out of resonance so far as they are concerned thus providing a low resistance or impedance which will not allow any appreciable power to be developed.

The Effect of Bias.—The efficiency of the arrangement is greatest when the pulses are high and narrow, and they can be made thus by increasing the bias applied, but it must be remembered that the drive must also be increased accordingly. It is the adjustment of the bias which makes the operation seem, at first sight, so unorthodox compared with its L.F.

counterpart. It is quite usual to bias a P.A. stage to twice—and even more—times its “cut-off” providing, of course, that there is sufficient drive available to warrant such conditions.

There is one point which must not be overlooked. The increase in efficiency obtained by the above methods is *not* an increase in the sense of obtaining greater output for a given input. For example, additional power is required to drive the grid swing hard over under such conditions. Similarly, if the drive is increased still further—with the object of getting even greater output, the input curve will cut too far into the positive area; grid current will flow, representing a power loss, and the drive will be—so to speak—held back.

The most, if not the only—efficient way of increasing the power of the output is to increase the anode high-tension and, at the same time, increase bias and drive. There are, however, limitations, the chief of these being the power which the valve can dissipate. The power lost often being sufficient to raise the anodes to a red heat, while large H.F. currents can produce sufficient heat to damage the structure of the valve and set up numerous troubles.

A Problem of Wattage.—The efficiency of suitable triodes, when operated under P.A. conditions, is in the region of a power ratio of 8 : 1, but, much better figures can be obtained from circuits using pentodes, although the actual percentage efficiency will depend, to a great extent, on the frequency concerned. Many beginners are not too clear regarding anode dissipation rating as connected with watts input to the aerial. For example, one might be using a valve, which, according to the makers' figures, has a safe anode dissipation of say, 30 watts, yet the input to the aerial might be 70 watts.

One is chiefly concerned with the anode efficiency of the stage, as will be made clear by the following. Supposing an efficiency of, say, 70 per cent is being obtained, and the input is 100 watts. Well, it is obvious that the input to the aerial will be only 70 watts or, in other words, 30 watts has been lost, the major portion of it being dissipated in the valve itself in the form of heat, therefore, it is essential that the valve selected must be capable of standing up to an anode dissipation of 30 watts.

Power amplifiers can be classified under three headings, according to the conditions under which they are operated.

Class A.—This is the most simple form. A triode valve is employed, the grid being biased so that the operating point is

brought onto the straight portion of the grid volts/anode current curve. If a signal is applied to the grid, an exact—though magnified—variation is produced in the anode current. The graphic representation is shown in Fig. 42 “a”.

With this type of amplifier, it is absolutely essential that the grid is not allowed to become positive, otherwise grid current will flow and violent distortion will be produced.

From the R.F. point of view, Class A has certain disadvantages; in fact, it is not now widely used, but more about that later. With a single triode, there is always the risk of

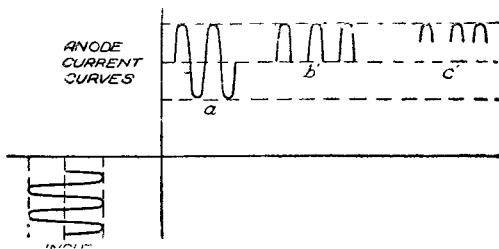

Fig. 42.—The different effects on a signal due to working on various parts of the grid-volts/anode-current curve.

considerable harmonic distortion unless particular attention is paid to the circuit design, operating conditions and component characteristics.

While with a single valve the efficiency is on the low side, it is possible to improve matters considerably, by using two triodes in Class A push-pull, and, what is even more important, such an arrangement practically eliminates distortion due to the even harmonics as they are cancelled out by virtue of the push-pull operation.

Class B.—This method might be considered as another form of the above, providing one remembers that the valves are operated under very different conditions. To commence with, a valve in Class B is always biased right down to its cut-off point, i.e., when no anode current flows. Consequently, when a signal is applied across its grid circuit, only the positive half wave has any effect on the anode current; the grid being rendered less negative by the application of the positive half wave, thus bringing the operating point up the curve away from the cut-off value and allowing anode current to flow. This will be appreciated more readily by reference to

the graphic representation Fig. 42 "b," where it will also be seen that the negative half wave only helps to make the grid still more negative, so it is not possible for any anode current to flow during that period.

While the efficiency of such an amplifier is considered quite good, it must not be overlooked that grid current will be set up which immediately introduces losses across the grid circuit, and these losses *have* to be made good by the preceding or driver stage. It is quite usual to employ a small power valve as driver. The importance of the above becomes more apparent when it is realized that the output of a Class B amplifier is proportional to the square of the exciting grid voltages.

When considering r.f. P.A. stages it is sometimes necessary to amplify the radio frequency *after* it has been modulated. An operation which calls for *linear* amplification, and when such requirements exist, a Class B amplifier can be used in the final stage.

Only one valve has been mentioned which, while being quite suitable for r.f. P.A. circuits is totally unsuitable for L.F. amplification. It is necessary, therefore, to use two valves—after the manner of Class A push-pull—each valve operating alternately on the positive half waves of the input. The anodes of the two valves are fed with H.T. through a centre tapped transformer and the resultant curve shape of the voltages induced in the secondary—from each half of the primary—is identical to that of the input.

Class C.—This method is nothing more than a Class B amplifier with different bias values. This is mentioned, as one is sometimes confused by the many names associated with circuits, especially when the name or term is such that it sounds to those not too familiar with circuits, as though it is something very weird and wonderful. With Class B the valve is biased down to cut-off point, whilst with Class C, the bias is increased to at least twice the cut-off value.

The effect of this increase in bias is to allow anode current to flow during a part of the positive half wave of the input only, as shown in "c" Fig. 42. By operating the valve under these conditions, it is possible to obtain a higher anode efficiency and greater power output, but the actual gain or amplification will be relatively low as the excessive bias has to be made up by the drive to the grid; therefore, it will be appreciated that ample power must be available for the drive if the full efficiency is to be obtained.

Neutralization.—It will be remembered that one type was known as a T.P.T.G. or, in other words tuned-plate tuned-grid, the valve being brought to a state of oscillation by tuning the plate and grid circuits to the same frequency. When using a triode as a P.A., there is always the great danger that it will act in the same manner. In fact, if suitable steps were not taken to prevent such an occurrence, the stage would become hopelessly unstable.

There always exists, between the plate and grid of a three-electrode valve a certain capacity. One might think of it as a very minute condenser connected across those two electrodes, and, while such capacity is not really serious when considering

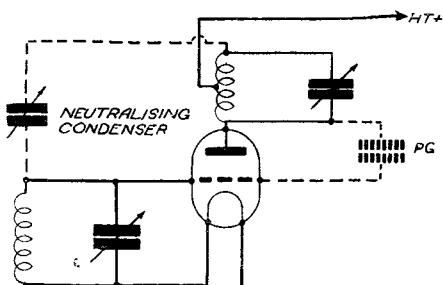

Fig. 43.—The inter-electrode capacity and method of balancing it out.

L.F. amplification, it can become a serious matter with R.F. stages. Its effect will be to allow some of the R.F. energy in the plate circuit to be passed back to the grid, and that, in the circumstances under consideration, would be sufficient to cause the valve to oscillate. A most detrimental factor in any amplifier. To overcome the plate/grid capacity feed-back, a very simple and novel arrangement is used. It is novel inasmuch that no attempt is made to stop the feed-back, as will be shown below:—

A triode, complete with tuned grid and anode circuits is shown in Fig. 43. The inter-electrode capacity is represented by the condenser P.G.

The anode of the valve receives its H.T. by means of the centre tap in the tank coil, and that point—so far as H.F. currents are concerned—can be considered to be at zero potential.

CHAPTER VII

MODULATION SYSTEMS

It has already been explained that the oscillator valve in a transmitter is solely concerned with the generation of radio-frequency oscillations at a predetermined and constant frequency. Such oscillations are responsible for the production of what might be termed a steady train of waves from the radiating system, the amplitude and frequency of which are maintained within definite close limits.

It is usual to refer to the waves thus produced as "continuous waves," or C.W., but when telephony is being considered they are more often spoken of as the "carrier waves," the reason for which will be apparent in the next few paragraphs.

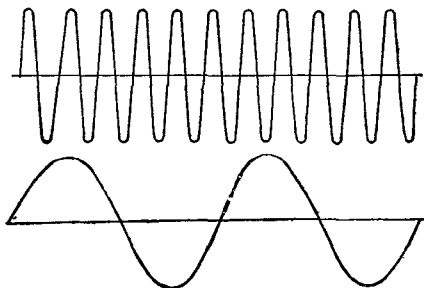

Figs. 45 and 46.—The constant carrier, and below, the applied L.F. oscillation.

What is Modulation? —Modulation can be thought of as the means or process whereby the radio frequency oscillations (carrier waves) are varied in such a manner that they convey the signal to be transmitted. Without some form of modulation, the carrier waves would be absolutely useless, so far as conveying any intelligence from one station to another.

The carrier waves can be modulated by (a) varying their frequency or (b) by varying their amplitude, and it is proposed to consider the latter, as it is the only satisfactory method so far as the amateur is concerned.

An imaginary radio-frequency wave is depicted, graphically, in Fig. 45, the waves having constant amplitude, while Fig. 46 represents a single tone sound. If the carrier is now modulated by the electrical equivalent of the sound, Fig. 45 becomes that shown in Fig. 47, where it will be seen that the

amplitude has been varied according to the wave-form of Fig. 46, or, in other words, one would say that the carrier is modulated, so that it is conveying the single-tone sound.

The new shape—dotted outline—is called the “modulation envelope,” and it will be noticed that it extends beyond the original limits—amplitude—of the carrier, but the frequency has not been changed in any way.

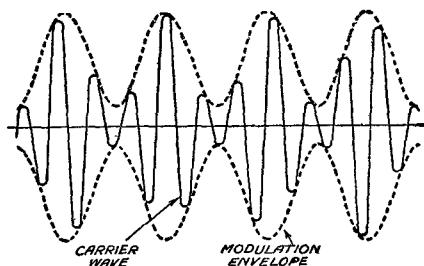

Fig. 47.—The result of combining the two impulses shown at Figs. 45 and 46.

When the carrier is modulated or, rather, when its amplitude is varied, additional frequencies are produced which are known as “side bands.” These are equal to the sum of the frequency of the carrier and the modulation frequency, and the difference between them. This may sound rather confusing, but it is an item which must be appreciated, as the following will show. When, say, the voice is being transmitted, the modulation frequencies can range as high as 2,500 cycles per second, approximately, which means that wave or frequency band covered by such a transmission would occupy 5,000 cycles, i.e. 5 Kcs.

Percentage Modulation.—It is possible to vary the amount of modulation applied to the carrier, and it is usual to express the amount as a percentage, the formula being thus:—

$$\frac{\text{Maximum modulated amplitude-carrier}}{\text{carrier amplitude}} \times 100 \%$$

A carrier, modulated 100 per cent, is shown in Fig. 48, and it should be noted that under such conditions, the carrier amplitude is increased to twice its normal amount, and reduced to zero. With a lower value, the graph would be similar to Fig. 49, while a higher percentage would produce Fig. 50 which indicates the state of over modulation.

Such conditions are *not good*; the modulation envelope becomes distorted, and the quality of transmission is seriously affected, while—due to the production of additional side bands

—the transmission channel becomes broader which, in turn, can cause unnecessary interference to local listeners.

Modulating Systems.—Except in the case of a low-powered single-valve outfit, such as the model recently described, it is not usual to apply modulation direct to the oscillator circuit as

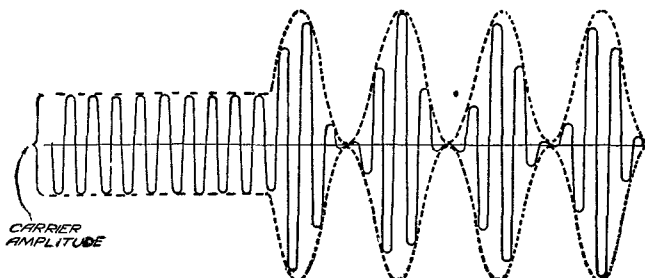

Fig. 48.—A carrier with 100% modulation.

such methods are likely to cause frequency variation which, in this instance, is to be avoided.

It is more general, therefore, to modulate the driven R.F. power amplifying stages as the following diagrams indicate.

Choke System.—This arrangement, also known as the Heising or “constant current” method of plate modulation, is shown in Fig. 51. The H.T. supply for the modulator and

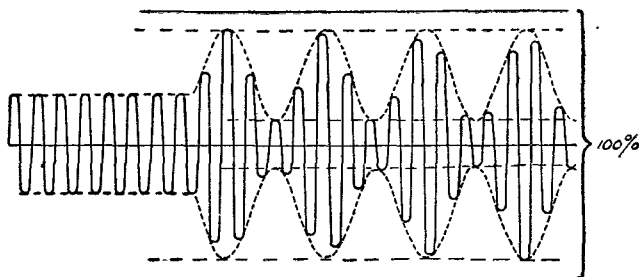

Fig. 49.—Showing the effects of modulation lower than 100%.

R.F. amplifier is supplied from a source common to both anodes, and through the L.F. choke Ch. which has, naturally, a very high impedance to low frequencies.

The low-frequency input is fed to the grid of the modulator, which operates as an ordinary L.F. amplifier, the anode circuit

of the R.F. amplifier acting as its anode load. Under operating conditions, the low-frequency output of the modulator is superimposed on the D.C. supply of the R.F. amplifier whose radio-frequency output is modulated accordingly.

To obtain satisfactory operating conditions with this system, it is necessary for the R.F. amplifier to be at a lower plate D.C. voltage than the modulator, so the resistance R

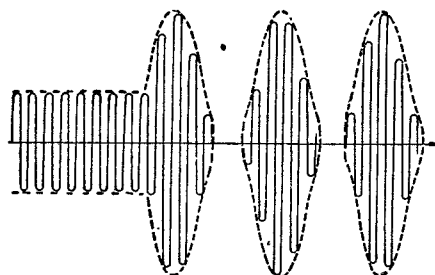

Fig. 50.—In this diagram the modulation is over 100%. Note the breaks in the envelope.

is embodied, an L.F. by-pass being provided by the condenser C.

Grid-bias Modulation.—This system is shown in Fig. 52, where it will be seen that the secondary of an L.F. output transformer is in series with the bias supply to the R.F. amplifier. Actually, the method is not recommended

for beginners, as more attention has to be paid to the R.F. amplifier to make up for a loss of modulated output, which is one of the disadvantages of the system.

The primary of the L.F. transformer is in the anode circuit of the modulator, and, during operation, the bias of the R.F. amplifier is varied at modulation frequencies which directly affect the radio-frequency output. Less low-frequency power is required to obtain full modulation, thus reducing the amount of gear necessary, but it must be remembered that the modulated carrier is also reduced, for given conditions, compared to the plate modulating systems.

Suppressor-grid Modulation.—A method which is becoming very popular is the use of pentodes in the R.F. amplifier, and obtaining modulation by variation of the suppressor-grid potential.

Such valves have very high efficiency, and quite small low-frequency power is sufficient to modulate large radio-frequency outputs, as a very small change in the suppressor-grid voltage produces a much greater change in the radio-frequency output.

A typical circuit is shown in Fig. 53.

Microphone Input Circuits.—To convert the sounds to be

The layout of the transmitter should be such that the microphone amplifier is well screened and remote from the remainder of the assembly, otherwise R.F. currents will be introduced into the L.F. circuits with dire effects.

When modulation is being considered, it is quite a common thing to think of additional frequencies being superimposed on the fundamental or carrier frequency, and one is inclined to apply the term to telephony only, overlooking the fact

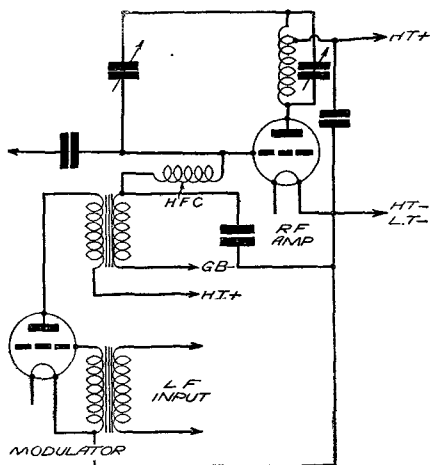

Fig. 52.—This circuit shows the arrangement for grid-bias modulation.

that modulation also takes place during telegraphic transmissions.

Keying and Keying Circuits.—Perfect keying is a pleasure to listen to, and a station very soon becomes known for perfect telegraphic transmissions; in fact, it might be said, and quite rightly, that the hall-mark of a station is the manner in which the key is handled, and the quality of transmission.

If morse signals are going to be radiated, then it is essential for the operator to concentrate on becoming key perfect.

For the first month or two, forget all about speed work, and concentrate on clean-cut signals, proper spacing and correct periods of contact for both dot and dash. Once these items have been mastered, speed will come much more easily, and your signals will be readable.

Object of Keying.—It is obvious that if telegraphic information is to be transmitted, some means must be provided whereby the aerial H.F. currents can be interrupted according to any pre-arranged code; for example, the morse code, and it is usual, with the types of transmitters under consideration, to use a hand-operated key for the purpose.

While it would seem quite an easy matter to insert a key or

switch to break the H.F. currents, there are certain requirements which must be considered, otherwise, variation in the frequency of the transmission will be produced ; severe interference will be caused to nearby receivers ; the possibility of shock to the operator and the oxidizing of the key contacts by arcing.

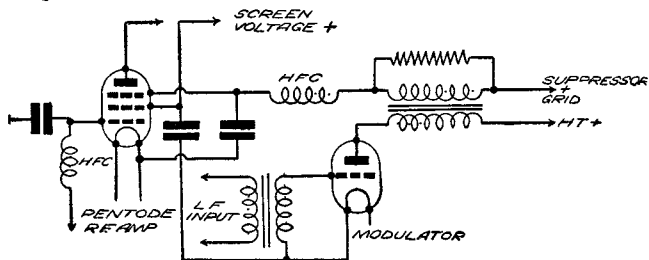

Fig. 53.—In this arrangement the system known as suppressor-grid modulation is employed.

One of the simplest ways of connecting the key is as shown in Fig. 55, where it will be seen that it is in series with the negative H.T. leads. Such an arrangement is quite satisfactory for low-powered outfits, but it must be appreciated that there is always a possibility of shock if contact is made between the two sides of the key.

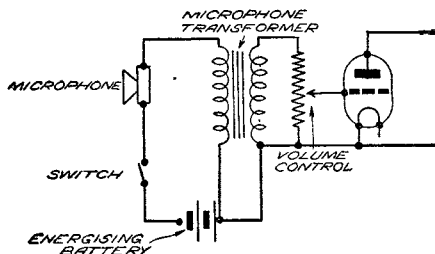
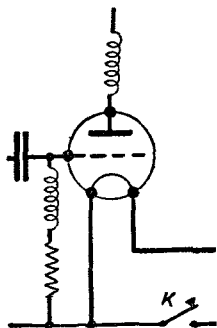
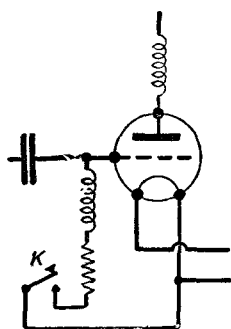

Fig. 54.—The best method of connecting the microphone is shown here.

More widely used methods are those shown in Figs. 56, 57, and 58, and which operate on the system of controlling the anode current by the application of correct bias when the key is in each position, i.e. open and closed. It will be noted that these methods eliminate the possibility of shock, therefore, they can be used on high-powered transmitters.

When it is realized that "*amplitude*" modulation is the form most widely used, it will be more readily appreciated how the operation of the key during morse radiations produces the desired effect, especially if Fig. 59 is considered.

The curve (Fig. 59) shows the graphical representation of a carrier wave, i.e. having constant amplitude or, in other words, unmodulated.



NOTE: R LIMITS CURRENT WHEN B IS SHORTED BY K BEING CLOSED

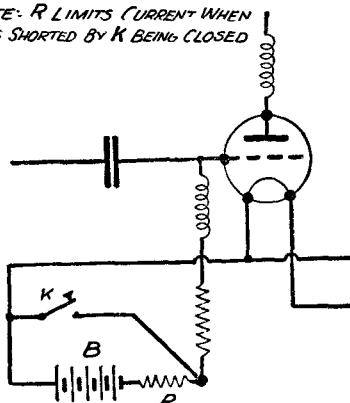

Figs. 55 and 56.—Suggestions for keying under varying battery circuit conditions.

If the key is now operated to send, say, the letter B, *dash, dot, dot, dot*, the resultant effect is similar to that shown by the curve in Fig. 60, the dotted lines indicating the shape of the modulation envelope.

It is quite possible for the wave-form or the shape of the modulation envelope to be a distorted reproduction of the ideal, due, in the majority of cases, to the lack of a key filter, or the use of one of poor design, unsatisfactory regulation in the H.T. supply, or the type of keying arrangement used. In certain circuits, the current will rise and fall too rapidly, producing a wave-form as indicated by Fig. 61, while "peaks" are often present (Fig. 62) when poor regulation of the H.T. supply is present.

With regard to the wave-form shown in Fig. 61 it is highly probable that interference will be caused to nearby receivers—even those tuned to ordinary broadcast wavelengths—in the form of key clicks, therefore, it is very desirable to avoid such distortion of the wave-form.

Keying Filters.—With the keying circuits already mentioned, the trouble can be eliminated by the use of a suitable keying filter, but, if primary keying is employed, then it will be necessary to give particular attention to the capacity of the smoothing condensers.

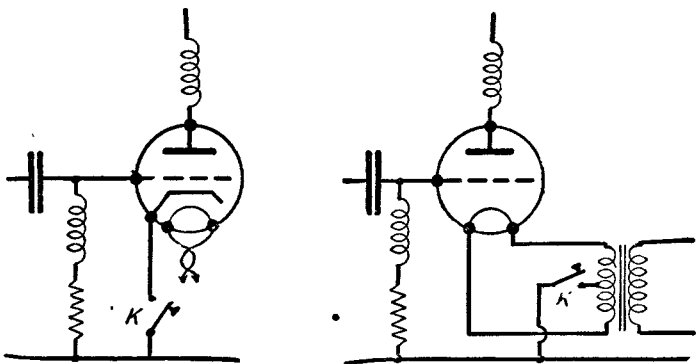

Figs. 57 and 58.—How to arrange for keying with mains-operated valves.

A simple but very effective filter is shown in Fig. 63. The L.F. choke L should have an inductance between ten and twenty Henries. In low-powered outfits, a lower value will often prove quite satisfactory, in fact, the primary of quite a small mains transformer will do or, if one is inclined, it is not a difficult matter to make up the component from the junk box.

The object of an L.F. choke, is to provide inductance which has the property of opposing sudden current changes, and use is made of this in the keying filter.

When the key is closed, a certain amount of energy is stored in the inductance, and its electro-magnetic field, of the choke, but, when the key is opened, the energy will be discharged, so to speak, back into the circuit.

If the current in the circuit is of appreciable value, the sudden release of the stored energy will, no doubt, cause

sparking at the key contacts which will not only harm the contacts, but also kill the object of the filter, as such sparking would cause interference.

To overcome this little snag, it is only necessary, fortunately, to connect a condenser across the key contacts, the capacity depending on individual conditions. Values between .25 mfd. and 2 mfd. should be tried.

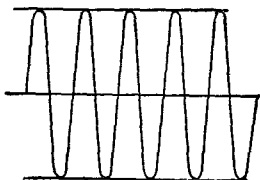

Fig. 59.—Diagrammatic representation of an unmodulated carrier wave.

Eliminating Sparking.—It will be appreciated that the condenser really prevents a sudden cut-off or cessation of the power, thus tending to round off the corners (Fig. 61), and eliminate sparking at the moment the key is opened.

If the circuit is now considered with the key open, it will be clear that if voltage is present across the key contacts when the key is open, the condenser will receive a charge, therefore, when the circuit is closed again, the charge will tend to

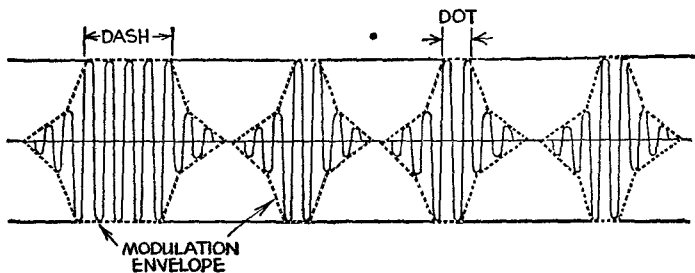

Fig. 60.—Diagram showing the effect of the letter "B" in modulating carrier.

produce sparking at the contacts. If, however, a suitable resistance is wired in series with the condenser, most of the trouble will disappear, as the energy will be absorbed by the resistance.

It is impossible to give hard and fast values, as so much depends on individual circuits and arrangements, therefore, it will be necessary for experiments to be made to determine

those most suitable. Anything from a 100 to 1,000 ohms may

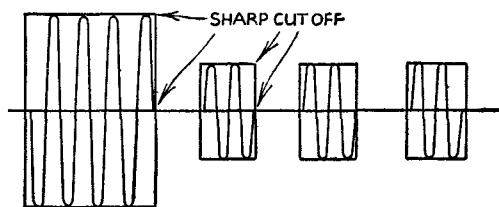

Fig. 61 (left).—In some arrangements a sharp cut-off will be obtained, whilst if poor regulation of the H.T. supply is provided, peaks will be produced as shown in Fig. 62 immediately below.

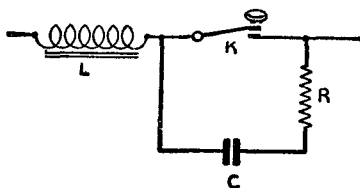
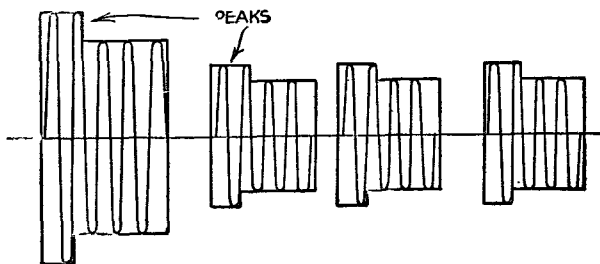

Fig. 63.—A simple keying filter circuit.

be necessary, in fact, it is a very wise idea to make the resistance variable.

CHAPTER VIII

ELECTRONIC RADIATION

THE "electronic" theory states, speaking in a practical sense, that an electric current is really nothing more than a movement of electrons (i.e. the smallest quantity of negative electricity which, with the proton, is the basis of all matter) and, if the movement is in one direction, it is usual to refer to the current as being "direct current." It will be remembered, however, that it is also possible to make the flow of electrons reverse periodically and set up an "alternating current."

Radiation.—Radiation, when applied to the subject under consideration, refers to the radiation of energy from the transmitting source.

The energy takes the form of electro-magnetic waves, waves which have an electric and a magnetic component, and which travel at the same speed as light, namely, 186,000 miles or 300,000,000 metres per second.

This energy is only radiated when the electrons are forced to get a move on or are pulled up with a jerk ; in other words, a circuit carrying "direct current" will not radiate during normal current flow, but only at the moment of switching on and off, i.e. starting and stopping.

With a circuit carrying "alternating current" (A.C.) however, the conditions are very different as the electrons are in a continuous state of starting and stopping, producing electro-magnetic waves as long as the current is switched on.

This state of affairs exists with all commercial A.C. supplies, but, as the frequency is so low, usually 50 cycles per second, the energy radiated is very small. The greatest radiation is produced by circuits carrying A.C. having very high frequencies, in fact, it will be found that the amount of energy radiated increases with frequency, i.e. the short wavelengths.

The waves have another characteristic in common with those of light, they can be reflected and refracted, as will be explained further on, thus allowing direction of maximum radiation to be pre-determined, as in "beam" transmissions.

Characteristics of Radiated Waves.—For normal broadcast requirements, it is possible to design transmitting aerials which will allow very even radiation in all directions,

particularly in the case of long waves. Under such conditions, the strength of the signal at the receiving aerial will, more or less, depend upon its distance from the transmitter, the signal gradually getting weaker and weaker as the distance increases.

With the higher frequencies (short waves), however, one cannot apply the same reasoning, as the behaviour of short waves is, to say the least, very erratic and greatly influenced by the items mentioned below.

Earth or Surface Waves.—For clearness the electro-magnetic

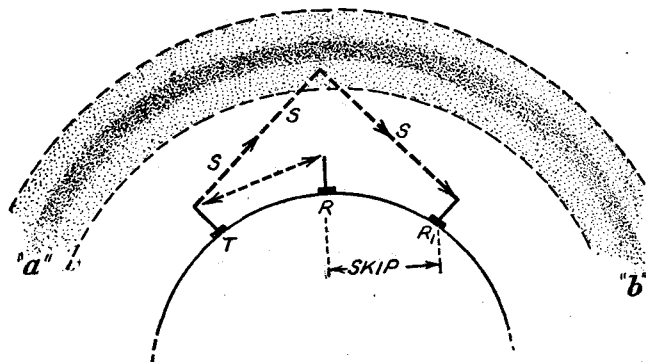

Fig. 64.—Diagram showing the effect of the reflected and direct waves of two separate receivers.

waves are divided into two groups, one of which can be classified under the above heading, and we will consider that one first.

When short waves are radiated from a transmitting aerial system some of them travel over the earth's surface or in the lower atmosphere, which is, comparatively speaking, fairly dependable, but, owing to the absorption of energy by earthed objects, such as trees, houses and the actual earth itself, they become attenuated or weakened rather rapidly and their effective range is, likewise, very limited. The effect becomes more pronounced as the frequency is increased, in fact, if the wavelength is down in the ultra-short band, the effective range almost becomes equal to the optical range, although, in view of the strange results now being obtained with the television transmissions, it does not seem possible to form any hard and fast rule.

Sky Waves.—Sky waves is an ideal name for these second group.

Through speaking about "Earth Waves" it must not be

CHAPTER VIII

ELECTRONIC RADIATION

THE "electronic" theory states, speaking in a practical sense, that an electric current is really nothing more than a movement of electrons (i.e. the smallest quantity of negative electricity which, with the proton, is the basis of all matter) and, if the movement is in one direction, it is usual to refer to the current as being "direct current." It will be remembered, however, that it is also possible to make the flow of electrons reverse periodically and set up an "alternating current."

Radiation.—Radiation, when applied to the subject under consideration, refers to the radiation of energy from the transmitting source.

The energy takes the form of electro-magnetic waves, waves which have an electric and a magnetic component, and which travel at the same speed as light, namely, 186,000 miles or 300,000,000 metres per second.

This energy is only radiated when the electrons are forced to get a move on or are pulled up with a jerk ; in other words, a circuit carrying "direct current" will not radiate during normal current flow, but only at the moment of switching on and off, i.e. starting and stopping.

With a circuit carrying "alternating current" (A.C.) however, the conditions are very different as the electrons are in a continuous state of starting and stopping, producing electro-magnetic waves as long as the current is switched on.

This state of affairs exists with all commercial A.C. supplies, but, as the frequency is so low, usually 50 cycles per second, the energy radiated is very small. The greatest radiation is produced by circuits carrying A.C. having very high frequencies, in fact, it will be found that the amount of energy radiated increases with frequency, i.e. the short wavelengths.

The waves have another characteristic in common with those of light, they can be reflected and refracted, as will be explained further on, thus allowing direction of maximum radiation to be pre-determined, as in "beam" transmissions.

Characteristics of Radiated Waves.—For normal broadcast requirements, it is possible to design transmitting aerials which will allow very even radiation in all directions,

particularly in the case of long waves. Under such conditions, the strength of the signal at the receiving aerial will, more or less, depend upon its distance from the transmitter, the signal gradually getting weaker and weaker as the distance increases.

With the higher frequencies (short waves), however, one cannot apply the same reasoning, as the behaviour of short waves is, to say the least, very erratic and greatly influenced by the items mentioned below.

Earth or Surface Waves.—For clearness the electro-magnetic

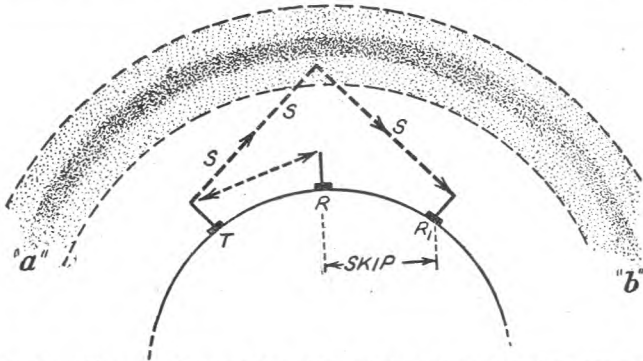

Fig. 64.—Diagram showing the effect of the reflected and direct waves of two separate receivers.

waves are divided into two groups, one of which can be classified under the above heading, and we will consider that one first.

When short waves are radiated from a transmitting aerial system some of them travel over the earth's surface or in the lower atmosphere, which is, comparatively speaking, fairly dependable, but, owing to the absorption of energy by earthed objects, such as trees, houses and the actual earth itself, they become attenuated or weakened rather rapidly and their effective range is, likewise, very limited. The effect becomes more pronounced as the frequency is increased, in fact, if the wavelength is down in the ultra-short band, the effective range almost becomes equal to the optical range, although, in view of the strange results now being obtained with the television transmissions, it does not seem possible to form any hard and fast rule.

Sky Waves.—Sky waves is an ideal name for these second group.

Through speaking about "Earth Waves" it must not be

thought that all the energy is radiated in that manner, far from it, as the greater amount of energy is, undoubtedly, radiated sky-wards at a small angle to the horizontal, and thus clears all surrounding earthed objects.

It is quite possible that these waves would go on travelling higher and higher and be of no use for communication purposes, if it were not possible for them to be reflected and refracted in the same manner as light.

Heaviside Layer.—At approximately 60 to 70 miles above the earth's surface there exists a layer of ionised atmosphere which is known as the Heaviside Layer after Oliver Heaviside, who, in 1902 put forward the theory of its existence.

The air molecules are ionised by collision due to bombardment by solar and cosmic radiations, and what really happens is that certain electrons and ions are rendered free to travel about, so to speak, on their own. The happy free state, however, doesn't exist for long; as the smashing up business goes on the free electrons and ions recombine to form neutral molecules, but, during their freedom the electrons have been on the move, and it is their movement which is chiefly responsible for the refraction of the waves which penetrate the ionised layer.

The whole idea will be more readily understood by referring to Fig. 64. Let T represent the transmitting station; R and R₁ receiving stations and the shaded band "a" "b" the ionised layer, or Heaviside Layer. The shading, in the band "a" "b" is intended to represent the density of the layer, i.e. the greatest number of free electrons in the centre of the layer.

The station R is at a distance from T, which comes within the range of the "earth or surface" waves, and the strength of the received signals will depend on the amount of absorption of energy, by earthed objects, between the two points. The other station, R₁, however, is beyond the effective range of the "earth" waves, and will depend on the "sky" waves for its signals, their path of travel being indicated by the dotted line "s" "s".

It will be noted that the path is turned back towards the earth by the ionised layer, and the turning process is due to a combination of reflection and refraction, according to the frequency of the waves. The higher the frequency, the greater the depth of penetration of the layer, and, consequently, the greater the distance between T and the point where they come in contact with the earth.

A peculiar point about the Heaviside Layer is that its height is greater at night time, and this, in turn, again affects

the range of the "sky" waves, as many amateurs will have, no doubt, noticed during reception tests.

It is assumed that there are other layers beside the Heavyside, in fact, it is known that another does exist, and it is known as the Appleton layer, which varies in height according to the season. It is estimated to be as much as 300 miles above the earth's surface during certain periods.

Skip Distance.—If the diagram is examined, it will be noted that any station situated in the area between R and R₁ does not receive either the ground or sky waves; in other words, it is in a "dead" area, and as the waves literally "skip" that distance it is usual to refer to such as the "skip distance."

It will be appreciated, therefore, that a transmitter might, quite possibly, not be received by a station, say, fifty miles away, but his signals would be received at good strength by a station many hundreds or thousands of miles away. As the frequency is reduced, i.e. wavelength increased, the sky wave is bent back earthwards at a more acute angle; in fact, above 80 metres, the waves will return earthwards within the range of the "earth" waves, besides, of course, greater distances.

Fading.—Before connecting the two paths open to electromagnetic waves with fading, it is necessary to get a general idea, even though it is a brief one, of "phase" relationship.

If two alternating currents are flowing in the same circuit and they have identical frequencies; they will augment or nullify each other, according to whether they are in phase or out of phase with each other.

Assuming that they are "in phase" with each other, then the maximum amplitude will be equal to the arithmetical sum of the two, and when such conditions exist, it is usual to state that the currents are "synchronized."

As the currents get "out of phase" the maximum amplitude will decrease, until when the phase difference or angle becomes 180 degrees, the amplitude falls to zero. This condition is known as "phase opposition." It is possible for a receiving station to be affected by earth waves and sky waves. Well, it is also possible for a time difference to exist between the reception of one and the other, such difference resulting in a phase difference between the two groups of waves. To make matters worse, the phase difference is not constant; it is possible for it to vary from moment to moment, and the resultant effect is to produce fluctuations in signal strength which are often classified under the heading of "fading."

CHAPTER IX

ONE-VALVE BATTERY-OPERATED TRANSMITTER

A Battery-Operated (One-Valver) 'Phone Transmitter.—The first transmitter for home constructors who have not yet explored the more serious and fascinating side of wireless, should be as simple as possible, consistent with the purpose it is intended to serve, namely, the progress of the operators' knowledge of wireless.

The circuit shown in Fig. 65 is not a new or original design, in fact, it is one which is already widely used by experimenters, and experienced transmitters, who require a low powered "stand-by" or "local" outfit.

It also possesses the advantages that, if at a later date, the user wishes to build a more powerful outfit, the components will be usable.

If the circuit is examined, it will be seen that the valve is an ordinary Class B, in this case, a Cossor 240B, which consists of two complete triodes, except for the common filament, in the one bulb.

If one triode circuit is traced, it will be seen that it forms a simple crystal-controlled oscillator circuit, which has its plate circuit tuned by the coil L, and variable condenser C, its resultant frequency or wavelength being governed by the crystal across the grid circuit.

That section, then, acts as the generator of the oscillations, but that in itself is not sufficient for our purpose. It is necessary to impress on those oscillations speech or music, so some means of "modulating" them have to be employed.

If the circuit of the other triode section is followed, it will be seen that it is nothing more than a L.F. amplifier, and it is used to amplify the minute electrical variations from the microphone circuit, until they are sufficient to modulate, fully, the oscillator output.

With a circuit of this type, a really efficient microphone, having a high output is necessary, therefore, a sensitive transverse current pattern is advisable.

The coil is perfectly straightforward, the design lending itself to home construction, if so desired, while the construction

of the complete transmitter should not present any difficulties to the average enthusiast.

Constructional Details.—One is often tempted to sling together test and experimental circuits or “hook-ups” but, with the class of work under consideration, an attempt should be made to make the job look neat and compact, so it is proposed to use what is known as “rack” construction, on very similar lines to the large transmitters, as such an arrangement not only looks good, but what is even more important, it is very reasonable in price, simple to make, and safeguards efficiency.

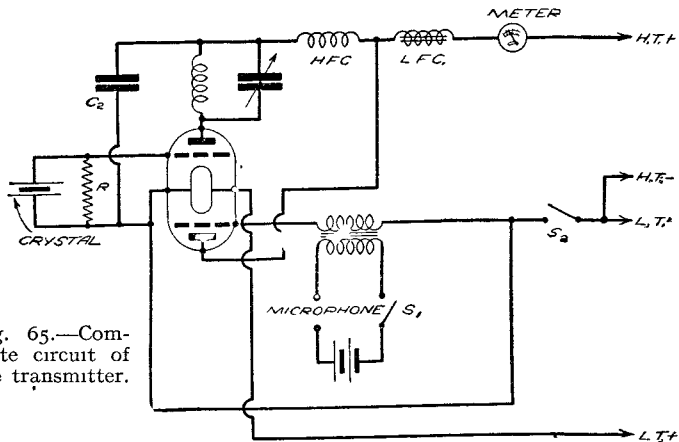

Fig. 65.—Complete circuit of the transmitter.

A general idea of the arrangement can be gathered from Fig. 66. The supports at each corner, and the four cross members are $\frac{3}{8}$ in. angle aluminium. Their dimensions are given in the diagram, together with those of the two baseboards.

The lower compartment is intended to house the batteries, while the upper one is for the actual transmitter, thus keeping all connecting leads short and constant, and making the whole outfit self-contained.

The sides of the structure are covered with perforated zinc, which allows ample ventilation for the battery compartment, and forms quite efficient screening for the circuit.

An ebonite panel is used for the transmitter, but the lower part and back can be covered with plywood stained black and left matt or polished, according to taste.

Constructional Details of Rack.—It is possible to buy all the parts for the "rack" ready drilled and cut to the right lengths, but for those who wish to buy the raw material and make it up themselves, a few more details will be helpful. Four 16 in. and four 9 in. lengths of $\frac{3}{8}$ in. angle aluminium will be required, 6 BA clearance holes being drilled in the positions shown in Fig. 67.

Do not start bolting these together until the perforated zinc sides are cut and fitted *into* the 16 in. angle pieces. The zinc sides, of which there are two, are 16 in. by 9 in., and it is essential for care to be taken in cutting them. Be sure that the long edges are parallel with each other and at right-angles to the top and bottom, otherwise the whole structure will be thrown out of square.

If the two sides are cut from a roll of material obtainable from one of the cheap stores, it will be possible to have a finished or solid edge for the top of the sides, thus making a much neater job.

Each zinc side must be framed by two 16 in. lengths of angle metal as shown in Fig. 68, after which the cross members can be bolted in position. The cross member fitted to the extreme ends forms the support for the floor of the rack, therefore, see that the solid end of the zinc sheets are at the other end, that is, the top. When the side sections have been completed, the bottom front ply panel can be placed in position inside the angle aluminium and made secure by four bolts. Again, it is necessary to check the whole thing up for "squareness," although the remaining parts will eventually lock everything up shipshape.

After this, the bottom floor can be considered, but remember

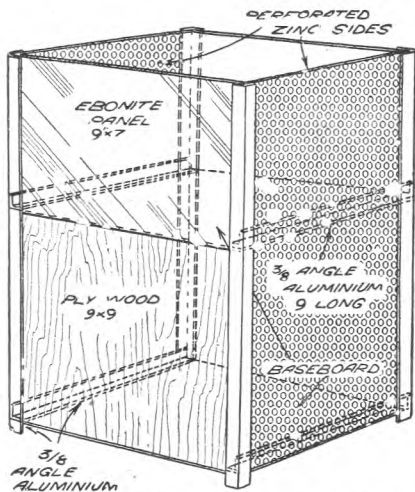

Fig. 66.—Containing case for the transmitter.

when cutting, that it is not 9 in. square; it is 9 in. by 9 in. less the thickness of the bottom front panel. The floor butts up against the panel, not under it.

Panel and Baseboard.—The panel is cut from sheet ebonite, its size being 9 in. by 7 in. by $\frac{3}{16}$ in. or $\frac{1}{4}$ in. thick and it is fastened to the baseboard by means of two aluminium brackets. Use a little care in fixing these, or else the appearance of the panel can be spoilt and the essential rigidity lost.

Before fixing the panel, remember to drill the two holes for the variable condenser and on/off switch, the condenser being mounted in the dead centre, and the switch in the mid position between edge of dial and baseboard. The simplicity of controls will be evident.

The Valve Mounting.—It should be noted that a chassis type of valve-holder is used, employing ceramic insulation material, therefore it is necessary to provide the platform shown in Fig. 69, which also allows short connecting leads to be used.

The brackets are made from aluminium, the dimensions being given in the diagram. They are quite easy to make, but if the constructor is not too keen on metal work, neat hard wood blocks could be used.

The platform itself is cut from bakelite or ebonite sheet, the circular hole being 1.2 ins. in diameter or, if a compass is not handy, scribe round a penny, cutting just inside of the line. A word of warning is necessary about the valve-holder. When fastening the holding bolts, be very careful not to exert too

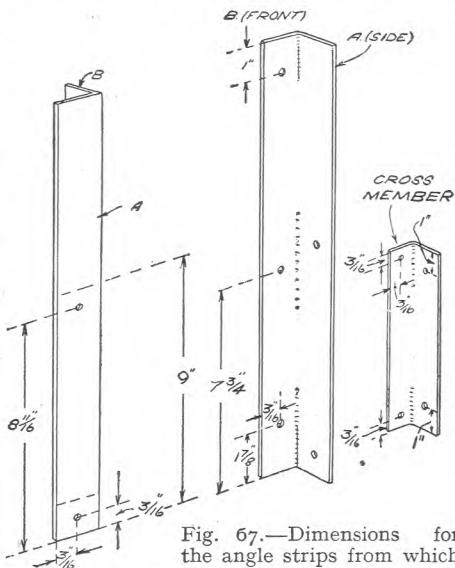

Fig. 67.—Dimensions for the angle strips from which the cabinet framework is made.

Constructional Details of Rack.—It is possible to buy all the parts for the "rack" ready drilled and cut to the right lengths, but for those who wish to buy the raw material and make it up themselves, a few more details will be helpful. Four 16 in. and four 9 in. lengths of $\frac{3}{8}$ in. angle aluminium will be required, 6 BA clearance holes being drilled in the positions shown in Fig. 67.

Do not start bolting these together until the perforated zinc sides are cut and fitted *into* the 16 in. angle pieces. The zinc

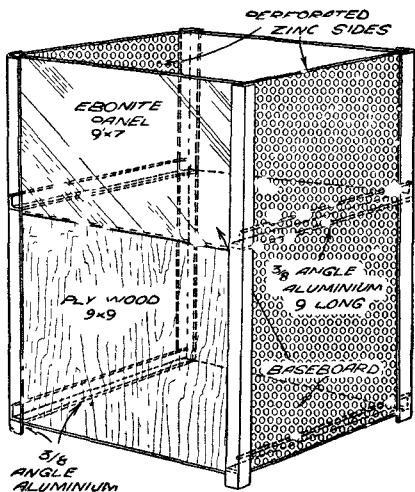

Fig. 66.—Containing case for the transmitter.

Each zinc side must be framed by two 16 in. lengths of angle metal as shown in Fig. 68, after which the cross members can be bolted in position. The cross member fitted to the extreme ends forms the support for the floor of the rack, therefore, see that the solid end of the zinc sheets are at the other end, that is, the top. When the side sections have been completed, the bottom front ply panel can be placed in position inside the angle aluminium and made secure by four bolts. Again, it is necessary to check the whole thing up for "squareness," although the remaining parts will eventually lock everything up shipshape.

After this, the bottom floor can be considered, but remember

sides, of which there are two, are 16 in. by 9 in., and it is essential for care to be taken in cutting them. Be sure that the long edges are parallel with each other and at right-angles to the top and bottom, otherwise the whole structure will be thrown out of square.

If the two sides are cut from a roll of material obtainable from one of the cheap stores, it will be possible to have a finished or solid edge for the top of the sides, thus making a much neater job.

when cutting, that it is not 9 in. square; it is 9 in. by 9 in. less the thickness of the bottom front panel. The floor butts up against the panel, not under it.

Panel and Baseboard.—The panel is cut from sheet ebonite, its size being 9 in. by 7 in. by $\frac{3}{16}$ in. or $\frac{1}{4}$ in. thick and it is fastened to the baseboard by means of two aluminium brackets. Use a little care in fixing these, or else the appearance of the panel can be spoilt and the essential rigidity lost.

Before fixing the panel, remember to drill the two holes for the variable condenser and on/off switch, the condenser being mounted in the dead centre, and the switch in the mid position between edge of dial and baseboard. The simplicity of controls will be evident.

The Valve Mounting.—It should be noted that a chassis type of valve-holder is used, employing ceramic insulation material, therefore it is necessary to provide the platform shown in Fig. 69, which also allows short connecting leads to be used.

The brackets are made from aluminium, the dimensions being given in the diagram. They are quite easy to make, but if the constructor is not too keen on metal work, neat hard wood blocks could be used.

The platform itself is cut from bakelite or ebonite sheet, the circular hole being 1.2 ins. in diameter or, if a compass is not handy, scribe round a penny, cutting just inside of the line. A word of warning is necessary about the valve-holder. When fastening the holding bolts, be very careful not to exert too

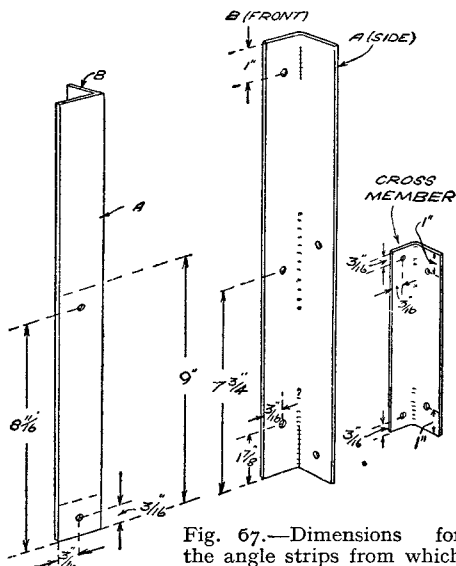

Fig. 67.—Dimensions for the angle strips from which the cabinet framework is made.

much pressure, otherwise there is a risk of cracking the ceramic material.

Bolt the aluminium brackets to the platform, but before screwing the assembly to the baseboard, connect to each required valve pin, except one filament, a piece of tinned copper wire about 9 ins. long. To the one filament pin left vacant, the red lead of a 12 in. length of red and black twin flex must be connected, the remaining black lead being taken to one side of the on/off switch on the panel.

Connecting the Components.—The crystal holder, L.F. choke

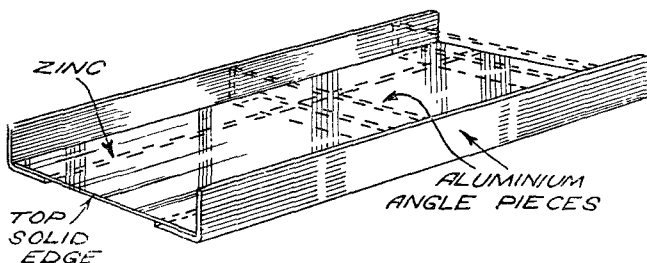

Fig. 68.—Details of the cabinet sides.

and microphone transformer can now be mounted on the baseboard, and the connections made according to plan. Be careful with the two anode/grid circuits. Don't connect anode 2 to the point where anode 1 is shown, and vice-versa.

LIST OF COMPONENTS FOR ONE-VALVE 'PHONE TRANSMITTER.

- | | |
|---|--|
| One ebonite panel, 9 in. by 7 in. by $\frac{3}{16}$ in. | Frequency 7 M.c. (Quartz Crystal Co.) |
| One valve—Cossor 240B. | Coil to specification (see text). |
| One variable condenser—B.T.S. .000067 type. Ceramic. | Two push-pull switches—Bulgin, type S.38 or S.22. |
| One fixed condenser, .001 mfd. | Two panel brackets—Bulgin type P.B.3 |
| One H.F.C.—short-wave—Eddy-stone. | One valveholder—B.T.S. U.H.7. |
| One L.F. choke—Varley. D.P. 11. | Two brackets. |
| One microphone transformer—Bulgin, type L.F.35. | One strip bakelite. |
| One dial—Bulgin, type I.P.8 | Four 16 in. lengths $\frac{3}{8}$ in. angle aluminium. |
| One knob, Bulgin, type K.58. | Four 9 in. lengths $\frac{3}{8}$ in. angle aluminium. |
| One terminal block, and two insulated head terminals. | Bolts (6BA), nuts, 2 spade ends, 2 H.T. plugs. |
| One Erie resistance, 30,000. | |
| One Quartz Crystal and holder. | |

Three holes must be drilled through the baseboard to allow the battery leads to pass down into the battery compartment. The microphone terminal block should be dealt with next, one terminal being connected to one side of the primary of the mike transformer, and the other fitted with a 4 in. length of flex to go to the on/off switch on rear panel. The centre-tap or the other side of the primary, according to the microphone in use, is joined to one of the flex leads from the mike battery.

The H.F. choke and .001 mfd. by-pass condenser should now be mounted, leaving the anode coil to the last.

The use of two switches and a terminal block may cause some comment. These components are used as they are

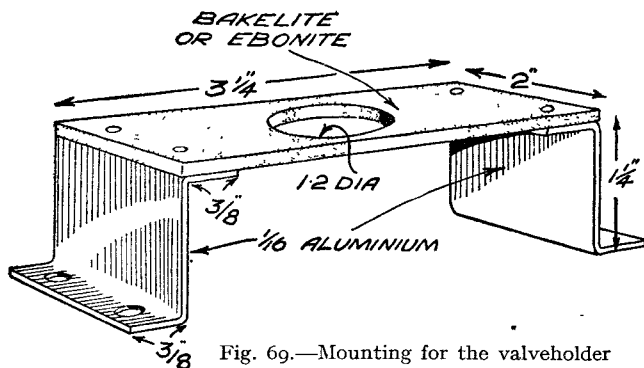

Fig. 69.—Mounting for the valveholder

more convenient from the experimenter's point of view, than a dual-purpose switch, and a plug and jack.

The Coil.—This is shown in Fig. 70 and is wound with 18 S.W.G. tinned copper wire on a six-ribbed, $1\frac{3}{4}$ ins. diam. good quality ebonite former or, better still, one of the special low-loss formers obtainable from Messrs. Peto-Scott or B.T.S. There are twenty turns, each turn being spaced $\frac{1}{8}$ in. and wound on as tightly as possible, each end being anchored through a small hole to their respective mounting strips. The brass strips, Fig. 70, are so arranged that they fasten direct on to the terminals of the fixed and moving vanes of the anode variable condenser, the coil being arranged just above the condenser. Before winding the coil, unwind about 5 yards of the wire and stretch it until all unevenness is removed. It will be noted that no tapping points, which are essential for

much pressure, otherwise there is a risk of cracking the ceramic material.

Bolt the aluminium brackets to the platform, but before screwing the assembly to the baseboard, connect to each required valve pin, except one filament, a piece of tinned copper wire about 9 ins. long. To the one filament pin left vacant, the red lead of a 12 in. length of red and black twin flex must be connected, the remaining black lead being taken to one side of the on/off switch on the panel.

Connecting the Components.—The crystal holder, L.F. choke

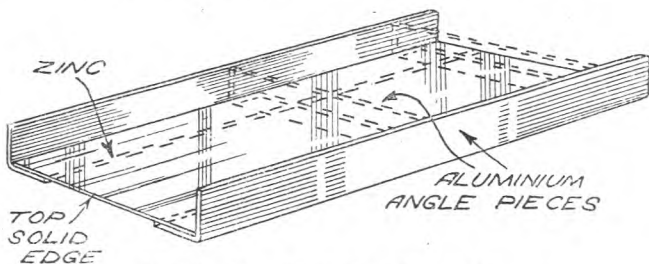

Fig. 68.—Details of the cabinet sides.

and microphone transformer can now be mounted on the baseboard, and the connections made according to plan. Be careful with the two anode/grid circuits. Don't connect anode 2 to the point where anode 1 is shown, and vice-versa.

LIST OF COMPONENTS FOR ONE-VALVE 'PHONE TRANSMITTER.

- | | |
|---|--|
| One ebonite panel, 9 in. by 7 in. by $\frac{3}{16}$ in. | Frequency 7 M.c. (Quartz Crystal Co.) |
| One valve—Cossor 240B. | Coil to specification (see text). |
| One variable condenser—B.T.S. .000067 type. Ceramic. | Two push-pull switches—Bulgin, type S.38 or S.22. |
| One fixed condenser, .001 mfd. | Two panel brackets—Bulgin type P.B.3 |
| One H.F.C.—short-wave—Eddy-stone. | One valveholder—B.T.S. U.H.7. |
| One L.F. choke—Varley, D.P. 11. | Two brackets. |
| One microphone transformer—Bulgin, type L.F.35. | One strip bakelite. |
| One dial—Bulgin, type I.P.8 | Four 16 in. lengths $\frac{3}{8}$ in. angle aluminium. |
| One knob, Bulgin, type K.58. | Four 9 in. lengths $\frac{3}{8}$ in. angle aluminium. |
| One terminal block, and two insulated head terminals. | Bolts (6BA), nuts, 2 spade ends, 2 H.T. plugs. |
| One Erie resistance, 30,000. | |
| One Quartz Crystal and holder. | |

Three holes must be drilled through the baseboard to allow the battery leads to pass down into the battery compartment. The microphone terminal block should be dealt with next, one terminal being connected to one side of the primary of the mike transformer, and the other fitted with a 4 in. length of flex to go to the on/off switch on rear panel. The centre-tap of the other side of the primary, according to the microphone in use, is joined to one of the flex leads from the mike battery.

The H.F. choke and .001 mfd. by-pass condenser should now be mounted, leaving the anode coil to the last.

The use of two switches and a terminal block may cause some comment. These components are used as they are

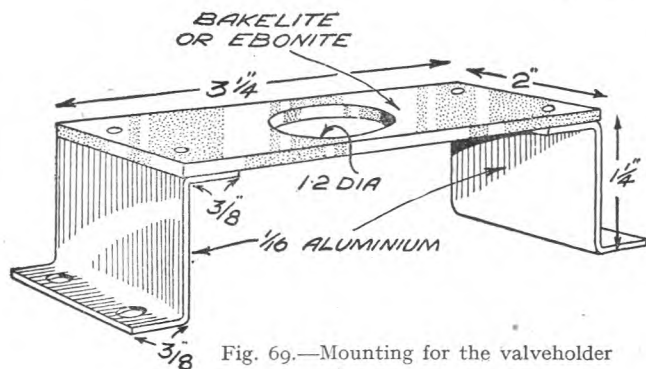

Fig. 69.—Mounting for the valveholder

more convenient from the experimenter's point of view, than a dual-purpose switch, and a plug and jack.

The Coil.—This is shown in Fig. 70 and is wound with 18 S.W.G. tinned copper wire on a six-ribbed, $1\frac{3}{4}$ ins. diam. good quality ebonite former or, better still, one of the special low-loss formers obtainable from Messrs. Peto-Scott or B.T.S. There are twenty turns, each turn being spaced $\frac{1}{8}$ in. and wound on as tightly as possible, each end being anchored through a small hole to their respective mounting strips. The brass strips, Fig. 70, are so arranged that they fasten direct on to the terminals of the fixed and moving vanes of the anode variable condenser, the coil being arranged just above the condenser. Before winding the coil, unwind about 5 yards of the wire and stretch it until all unevenness is removed. It will be noted that no tapping points, which are essential for

use with a radiating aerial, are shown. They will be mentioned later on, as it is first intended to consider the transmitter with an artificial aerial, which will be described in detail later on.

When all wiring is completed, the apparatus can be fitted into the rack and the back panel mounted, the microphone on/off switch having been mounted just above the terminal block cut-out.

The panels keep the perforated zinc tight against the corner pieces, and make the whole structure quite rigid and firm. In

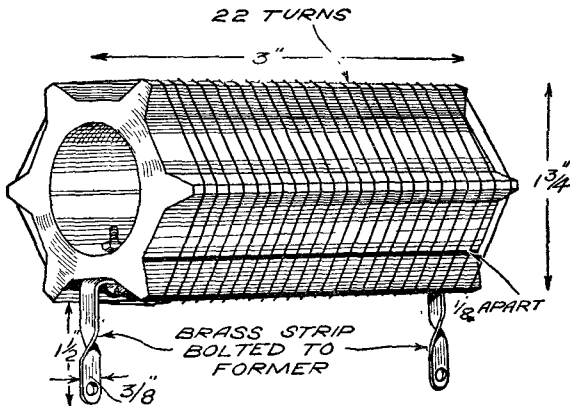

Fig. 70.—The coil is made up as shown here. 18 S.W.G. tinned copper wire is used.

this respect, it is advisable to bolt the ebonite panel to the angle aluminium by one bolt, each side, about 1 in. from the top edge. For a permanent job, the baseboard should be bolted to the side cross pieces, as all such fixing strengthens the whole assembly.

Before proceeding with the operating details of the transmitter, there are one or two points which must be emphasized. Referring to Fig. 65, particular attention should be paid to the condenser C₂, which forms an H.F. by-pass between the H.T. end of the anode tank coil and the common earth negative line. Without the condenser C₂ the circuit will not function; although it is a vital component, and should be of the mica dielectric type, its actual capacity is not critical, the value specified being an average, and one quite satisfactory for the valve concerned.

See that one end of it is fastened securely to the variable condenser terminal which holds one end of the tank coil and that the other side is taken direct to the nearest earth point, i.e. the L.T. switch.

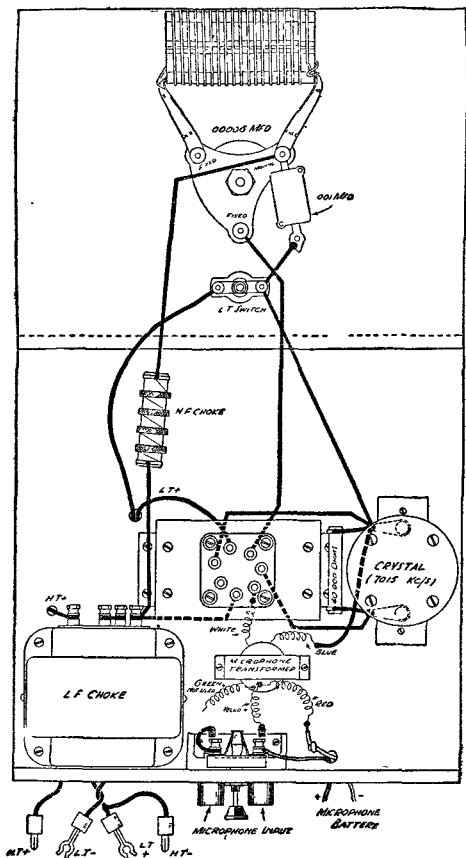

Fig. 70A.—Wiring plan of the theoretical circuit shown in Fig. 65. Note that H.T.— is joined to L.T.—.

Grid Leak.—The oscillator section of the 240B depends for its bias on the value of the resistance R, which is across the grid filament circuit, and the grid current flowing; therefore,

it is practically impossible for me to specify a value which will give the most efficient results under various conditions. The resistance quoted, 30,000 ohms, is a satisfactory value for general operation, but the beginner and experimenter are advised to fit, say, a 0.5 megohm variable resistor of reliable make in place of the fixed resistor. This suggestion is offered not as a correction, but as a tip to those who wish to gather as much information as possible about the behaviour of a crystal-controlled oscillator. It will be found that the most instructive and interesting experiments can be carried out with a variable grid resistance as will be explained later.

Anode Meter.—Referring once again to Fig. 65, it will be seen that a milliammeter is shown in the H.T. feed line, between the H.T. source of supply and one end of the L.F. choke.

Its position on the transmitter rack is shown in Fig. 71, which indicates how it is mounted in or on the bottom front panel. Such an arrangement brings the meter terminals just where they are wanted, doing away with long external leads, while the dial is clearly visible from all angles and adds to the appearance of the job.

A meter having a full-scale reading of 30 mA. will be quite satisfactory, although if one having a lower maximum reading is to hand there is no reason why it should not be used, providing suitable shunts are fitted to render it suitable for the maximum current flowing.

On the other hand, it is not advisable in this instance, to use a high-reading meter, otherwise the current variations, which indicate so much, will not be indicated as clearly as with the meter specified. For a similar reason, a reliable moving-coil meter should be used; don't waste money on a cheap unknown make.

H.T. Supply.—For satisfactory operation, a supply of 150 volts is really required, and this can be obtained from dry batteries or an eliminator.

For those without A.C. or D.C. mains a 120-volt battery in series with a 60-volt, the batteries being preferably of the super-capacity type, are suggested.

The H.T. current consumption is comparable to the average three-valve receiving set using a pentode output, and bearing in mind that the transmitter is not likely to be used for the same number of hours per day as a receiver, there is no need to fear costly H.T. replacements.

Eliminators.—Where possible, the use of an eliminator is by far the best proposition, as a higher voltage can be used without any increase in running costs, and a greater output obtained from the transmitter.

There are, however, one or two items to watch. It is essential to see that adequate and efficient smoothing arrangements are provided. In many instances low-resistance L.F. chokes have to be inserted in each supply lead to eliminate every trace of ripple. Fig. 72 shows the idea and the position of the necessary smoothing condensers.

Although excessively high voltages will not be used in the circuit in question, it is advisable to get into the habit of including some form of indicator to denote when the mains are on, otherwise some very nasty shocks may be received when carrying out any rapid alterations. This applies chiefly to larger transmitters, but in any case it is safer to get into the habit of looking for the indicator, so a neon bulb or low-wattage mains lamp should be wired in circuit with the supply.

Fuses should always be embodied between the *double-pole* mains switch and the primary of the mains transformer, when on A.C., and between switch and smoothing arrangements on D.C. As is usual with D.C. circuits, the earth connection must *not* be taken direct to the common negative side of the circuit; a reliable make of fixed condenser of, say, .05 mfd., should always be in series with the earth lead.

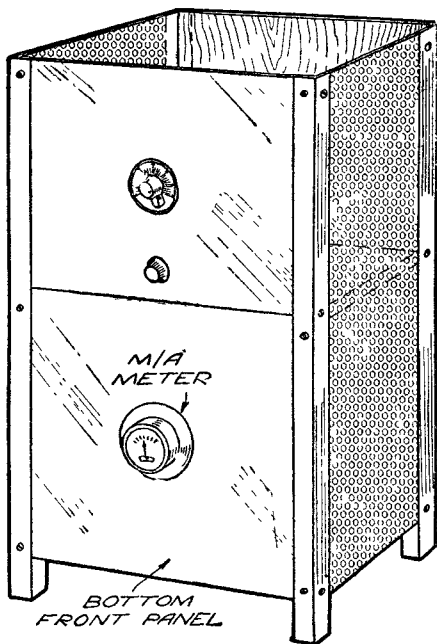

Fig. 71.—General view of the cabinet, with meter in position.

it is practically impossible for me to specify a value which will give the most efficient results under various conditions. The resistance quoted, 30,000 ohms, is a satisfactory value for general operation, but the beginner and experimenter are advised to fit, say, a 0.5 megohm variable resistor of reliable make in place of the fixed resistor. This suggestion is offered not as a correction, but as a tip to those who wish to gather as much information as possible about the behaviour of a crystal-controlled oscillator. It will be found that the most instructive and interesting experiments can be carried out with a variable grid resistance as will be explained later.

Anode Meter.—Referring once again to Fig. 65, it will be seen that a milliammeter is shown in the H.T. feed line, between the H.T. source of supply and one end of the L.F. choke.

Its position on the transmitter rack is shown in Fig. 71, which indicates how it is mounted in or on the bottom front panel. Such an arrangement brings the meter terminals just where they are wanted, doing away with long external leads, while the dial is clearly visible from all angles and adds to the appearance of the job.

A meter having a full-scale reading of 30 mA. will be quite satisfactory, although if one having a lower maximum reading is to hand there is no reason why it should not be used, providing suitable shunts are fitted to render it suitable for the maximum current flowing.

On the other hand, it is not advisable in this instance, to use a high-reading meter, otherwise the current variations, which indicate so much, will not be indicated as clearly as with the meter specified. For a similar reason, a reliable moving-coil meter should be used; don't waste money on a cheap unknown make.

H.T. Supply.—For satisfactory operation, a supply of 150 volts is really required, and this can be obtained from dry batteries or an eliminator.

For those without A.C. or D.C. mains a 120-volt battery in series with a 60-volt, the batteries being preferably of the super-capacity type, are suggested.

The H.T. current consumption is comparable to the average three-valve receiving set using a pentode output, and bearing in mind that the transmitter is not likely to be used for the same number of hours per day as a receiver, there is no need to fear costly H.T. replacements.

Eliminators.—Where possible, the use of an eliminator is by far the best proposition, as a higher voltage can be used without any increase in running costs, and a greater output obtained from the transmitter.

There are, however, one or two items to watch. It is essential to see that adequate and efficient smoothing arrangements are provided. In many instances low-resistance L.F. chokes have to be inserted in each supply lead to eliminate every trace of ripple. Fig. 72 shows the idea and the position of the necessary smoothing condensers.

Although excessively high voltages will not be used in the circuit in question, it is advisable to get into the habit of including some form of indicator to denote when the mains are on, otherwise some very nasty shocks may be received when carrying out any rapid alterations. This applies chiefly to larger transmitters, but in any case it is safer to get into the habit of looking for the indicator, so a neon bulb or low-wattage mains lamp should be wired in circuit with the supply.

Fuses should always be embodied between the *double-pole* mains switch and the primary of the mains transformer, when on A.C., and between switch and smoothing arrangements on D.C. As is usual with D.C. circuits, the earth connection must *not* be taken direct to the common negative side of the circuit; a reliable make of fixed condenser of, say, .05 mfd., should always be in series with the earth lead.

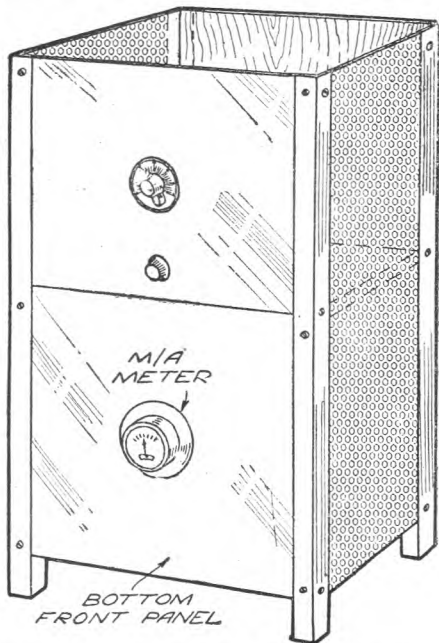

Fig. 71.—General view of the cabinet, with meter in position.

There is one other very satisfactory source of H.T. supply if mains are not available, and that is accumulator H.T. cells. These are capable of supplying a very steady current, free from any trace of hum and chemical noises, while they will stand up to a much heavier current drain than the usual dry H.T. battery and, of course, after the initial outlay, they are more economical.

Modulation.—So far no mention has been made about modulating the oscillations produced in the crystal circuit of the 240B, therefore, just a few words about suitable microphones and their operation.

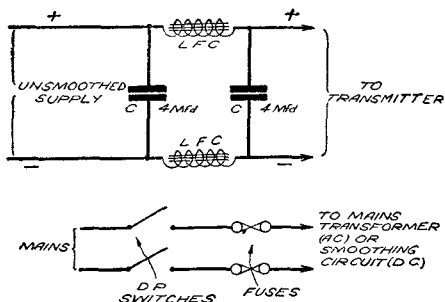

Fig. 72.—Suggestions for eliminators for operating the receiver from the mains, both A.C. and D.C.

With the microphone transformer specified and with the amplification available, it is necessary to use a fairly sensitive "mike," otherwise satisfactory modulation of the signal will not be obtained.

There are many carbon "mikes" on the market, ranging from simple button affairs to elaborate transverse current jobs, so consideration must be given to the selection of a suitable instrument.

The "mike" is connected to the two terminals provided on the back panel of the rack by a length of ordinary twin flex, and placed in a position most convenient to the operator.

Either ratio of the Bulgin microphone transformer can be used, the higher giving greater output but not quite such good quality.

When modulating with speech, don't speak *into* the "mike," place the mouth fairly close to the microphone, say 9 in., and speak, clearly, *across* the metal grille.

Gramophone records can be used either by reproducing them through the "mike" or by using a pick-up, the P.U. leads being connected across the secondary of the microphone transformer. If so desired, both the "mike" and P.U. can be used at the same time, thus allowing details to be given of any adjustments made during the transmission of the record.

In the case of a single operator, the P.U. will be found most useful, as the test receiver can be placed in some remote part of the house, and the transmission checked while the gramophone continues to modulate the signal.

Operation of the Transmitter.—With all batteries connected but without any aerial or earth, and the milliammeter in the positive H.T. supply, switch on and watch the meter. The variable condenser should be closed, i.e. maximum capacity.

When the needle has reached the end of its travel, the

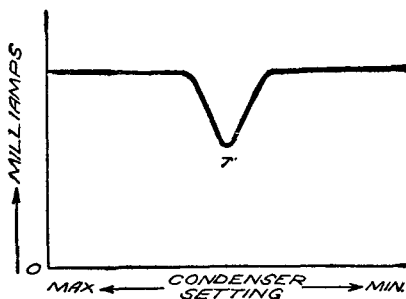

Fig. 73.—Curve showing the resonant point.

exact setting depending on the value of H.T. and grid leak, slowly rotate the condenser towards minimum, and still *watch the meter*.

What should happen is this. A setting of the condenser will be reached where the current will take a sudden dip downwards, and then, as the condenser capacity is still further reduced, the needle will commence to swing back again towards its original position.

If the current readings are plotted against condenser settings, a curve like that shown in Fig. 73 will be obtained if all is well.

At the point T, i.e. minimum current reading, the anode tank coil circuit is tuned to resonance with the grid circuit, or in other words, the transmitter is producing the required oscillations, and, when the needle swings upwards, oscillations cease. More will be said about these effects later on.

If the microphone is then switched on, it will be possible to see minute variations in the current reading when the "mike" is flicked with the finger (the case not the diaphragm)

providing the oscillator and modulator sections are working properly.

If a test receiver is handy, which it should be, it will be found that the signals can be picked up if the receiver is tuned to the transmitter frequency.

Loop-lamp Test.—There is another very simple yet instructive way of checking up the transmitter adjustments, which does not require the use of a meter. It is the “looped-lamp” method, which employs an ordinary low consumption—in this instance, pocket lamp—bulb, the contacts of which

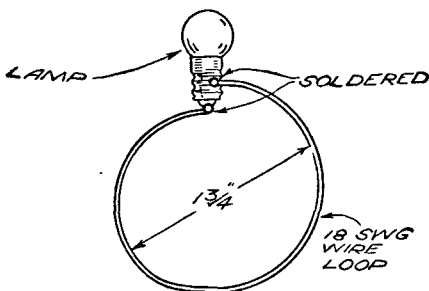

Fig. 74.—The “looped-lamp” circuit indicator.

are soldered to the ends of a loop of, say, 18 S.W.G. tinned copper wire which is bent to form a loop or circle having a diameter approximately equal to that of the tank coil. Fig. 74.

The loop should be held near, but not touching, the end turns of the tank coil, and if 200 or more volts are being applied on the H.T. side, it will be possible to make the lamp glow. When the maximum output is being given, the lamp will give the brightest light.

The same effect can be produced with lower H.T. voltages, depending on the type or current consumption of the lamp. It must be remembered that the average $4\frac{1}{2}$ -volt pocket lamp takes .3 amp., i.e. 300 mA., while some of the 8-volt type only take .2 amp. The properly rated fuse bulbs produced by Messrs. Bulgin are most useful, as they can be obtained for very low current readings.

Artificial Aerial.—It is necessary, with an Artificial Aerial licence, to employ some form of dummy aerial which will absorb, so to speak, the output of the transmitter, thus preventing radiation over distances beyond the immediate vicinity of the apparatus.

The theoretical diagram is shown in Fig. 75, where it will be seen that very few parts are required. The average aerial has inductance, resistance and capacity, so the same qualities are embodied in the dummy or artificial arrangement, the coil L providing the inductance; C, a condenser, the capacity, and R the resistance.

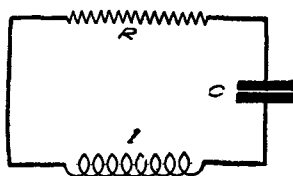

Fig. 75.—Theoretical representation of an artificial aerial system.

For the present purpose it is advisable to make the A.A. so that it can be tuned, and provide it with some means of indicating the effectiveness of the transmitter. To do this, the condenser C is made variable, and the resistance R is replaced with a small lamp.

The construction is quite simple, Fig. 76 showing the position of all parts, and the three wires connecting them. The coil can be made identical to the anode tank coil, or a

more simple and flexible way is to use a B.T.S. plug-in 24-52 metre coil, which was the method I adopted.

The extension rod (Bulgin) is essential, as it allows accurate adjustment to be made without any capacity effects from the hand.

The variable condenser is of the S.W. type and has a capacity of .00016 mfd. or .0002 mfd.

The lamp calls for particular attention and, maybe a little experiment before a suitable one is found, owing to the variation in current consumption

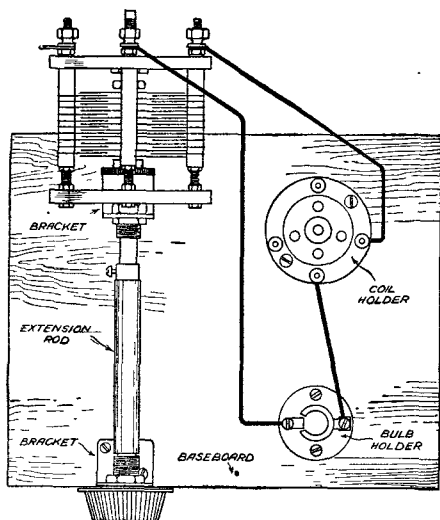

Fig. 76.—Layout and wiring of the artificial aerial for use with the transmitter.

of different types. Use, on limited H.T. voltages, low-consumption fuse bulbs, but these, unless reliable ones like Bulgins are used, are also liable to vary widely as regards actual current. With H.T. voltages of 200 and over, no trouble is experienced, in fact, as the power of the transmitter increases, so must the wattage of the lamps otherwise frequent replacements are necessary.

As soon as the Artificial Aerial unit is completed, tests can be commenced to determine the most satisfactory form of coupling between the transmitter and the A.A., and, when that has been done, to secure maximum output from the 240B valve. There are several ways of coupling the A.A.;

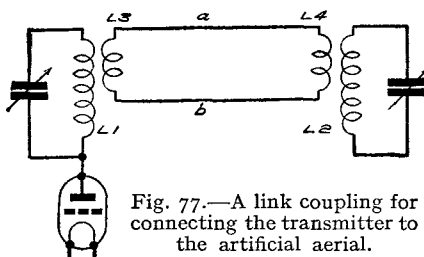

Fig. 77.—A link coupling for connecting the transmitter to the artificial aerial.

for example, it is possible to connect the anode tank coil circuit to the A.A. coil by means of a very small fixed or variable condenser, but such an arrangement, while being quite satisfactory in many respects, introduces one or two undesirable features, so it is best to consider other methods. The tank coil and the A.A. coil can be inductively coupled, such a method approaching the ideal, but the trouble in this case is that it is not always convenient or practicable to arrange the necessary coupling, either by reason of space or coil construction.

“Link” Coupling.—It is possible, however, to make use of a modified form of inductive coupling which, while allowing the power or energy in the tank coil to be transferred to the A.A., also allows the two coils to be separated from each other by a convenient distance, according to operating requirements.

Such an arrangement is known as “link” coupling, and the beginner is advised to give the method some consideration as it is used quite a lot with transmitting apparatus. The theoretical circuit of the form under consideration is shown in

Fig. 77 where L1 and L2 represent the tank and A.A. coils

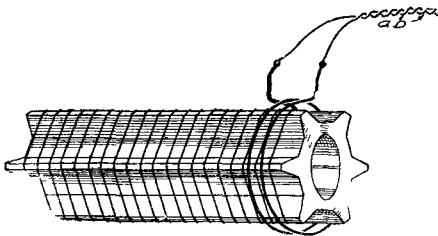
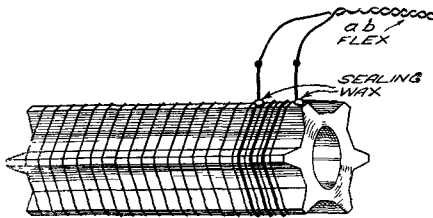

Figs. 78 and 79.—Alternative methods of affixing a coupling coil to the tank cell.

and L3 L4, together with the connecting leads, "a" "b", the "link" coupling.

It will be noted that as L1 and L2 are separated from each

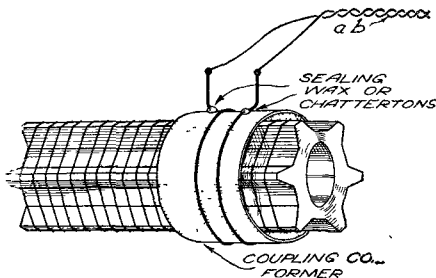

Fig. 80.—Another, and simpler, method of arranging for the coupling coil.

other, no mutual inductive coupling can take place, while the possibility of capacity coupling, due to the distributed capacity of the windings, is reduced to a minimum.

It is not possible to tie down the exact number of turns of

the coils L_3 , L_4 or their exact positions in relation to the other coils, but it can be taken that $1/10$ th of the number of turns on the main coils will be a satisfactory basis for the number to be used for the coupling coils. As regards their position on L_1 and L_2 , that is best determined by experiment, commencing from the low H.F. potential end of the tank coil, i.e. end remote from anode, and adjusting them until the maximum power is transferred.

Coil Construction.—The construction is quite simple, in fact, it lends itself to the skill or ideas of the constructor, as the formation of the coupling coils and the degree of coupling can be obtained in so many ways. Figs. 78, 79 and 80 show three methods, each of which allows the degree of coupling and the position of the coupling coil to be varied. While this part of the experiment may seem rather tiresome, don't gloss over it, and assume that all is well with the first arrangement; try several positions and vary the number of turns *and note the results obtained* with each attempt.

The connecting leads "a" and "b" are called "feeders" and should consist of spaced wires or twisted twin flex, thus forming what is known as a "low impedance" line. The length is not critical, in fact, it can be anything from a few inches to several feet, although, in this instance, it is not necessary to make it longer than that required to allow the A.A. to be placed alongside the transmitter.

If a plug-in coil is used in the A.A. unit, there is no harm in trying the reaction winding as a coupling coil, providing 200 volts or over are being used on the transmitter, otherwise the coupling may be too loose for the power available.

Operation with A.A.—With the transmitter switched on, and the feeder line broken, adjust the tank coil circuit variable condenser until the maximum *dip* is indicated by the milliammeter needle. Now complete the feeder or link circuit and note the rise in current, that is, if all is well with the adjustment of the oscillator. The tank tuning condenser must now be adjusted to produce, again, the greatest dip of the meter needle, and, when that state is reached, the A.A. circuit is pulling or receiving the maximum output. It is at this stage that experiments should be made with the position of the coupling coils, and the degree of coupling.

Unless, by chance, the A.A. happens to be tuned to the exact frequency of the transmitter, it will, of course, be necessary to tune that circuit as well until the brightest glow is

produced in the lamp. It will be found that the tuning is rather critical, and unless high H.T. is used on the 240B valve the glow will, at first, be very faint. Remember that it is essential to use a low consumption lamp.

The Grid Leak.—It has been mentioned about using a variable resistance in place of the fixed grid resistance, for experimental purposes, and those who have taken the tip will soon appreciate how the value of the grid resistance can affect the operation of the oscillator.

It will be possible to set the variable resistance to a fairly low value and secure quite a *bright* light from the lamp in the A.A. circuit, and, on the other hand, make the resistance too high and not secure any visible effects.

Do not fall into the trap that the low value, and bright light, indicates that all is well. Just revert to the milliammeter and see what is happening. The following effect can be produced: starting from maximum capacity of the tank tuning condenser and slowly opening the vanes, the needle will give an *upward* kick, when oscillations commence, before taking the downward dip. When such indications are noted, and they must be watched for, it is pretty safe to assume that the grid resistance is *too small*, and that a higher value is required. By careful adjustment of the resistance, it is possible to arrive at a point where the maximum output will be given and the meter needle will perform in the proper manner, i.e. a sudden dip as oscillations start, and then a rise as the resonant point is passed. Stating the requirements rather boldly, the circuit should always be tuned for the maximum dip or minimum reading.

Modulating.—After having adjusted the circuits to utmost efficiency, switch the microphone into circuit and test for visible indication, by the meter or lamp, that it is modulating the oscillator output, when, of course, sound is directed into the "mike" or the case flicked with the finger. If all is well, the meter needle should fluctuate, and the intensity of the glow of the lamp vary.

A fairly sensitive microphone is necessary, but remember that sensitivity without quality of reproduction is useless. Keep the microphone to one side of the transmitter rack, and the A.A. unit to the other; if a gramophone pick-up is used, keep that also on the same side as the microphone.

CHAPTER X

AERIALS

THE question of aerials for transmitting is one which has to receive reasonable consideration and, unlike receiving installations, it cannot be disposed of with the "that's good enough" attitude. In fact, it would be quite true to say that unless careful attention is paid to the design and construction of the radiating portion of a transmitter, the results will be *most* disappointing and, possibly, a continual source of perplexity. The types of aerials are many and varied, and the beginner will do well to select the most simple, according to local conditions and transmissions concerned, and investigate the

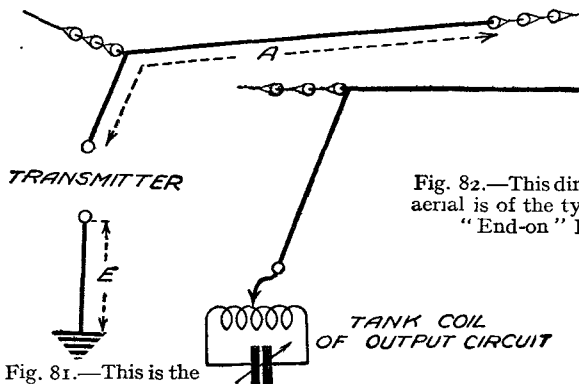

Fig. 81.—This is the popular Marconi aerial.

Fig. 82.—This directly-excited aerial is of the type known as "End-on" Hertz.

properties of the more elaborate forms as he progresses with the subject. There are one or two points which must be noted when selecting the site, and when erecting the aerial, and if it is remembered that one is dealing with the radiation of a very low-powered signal, and *not* the reception of a transmission several times as strong, the transmitter output will stand a much better chance of "getting over."

Firstly, height is an all-important factor; every foot helps, so give that item some little thought, and get the suspension points as high as conditions will allow.

Secondly, select a site which will enable the aerial to be as far away as possible from all earthed objects, by which is meant houses, trees, telephone lines and cables and roofs.

Thirdly, see that the use of insulators is not skimped and that all joins, if any, and connections are soldered, while the suspension is such that the whole rig is reasonably taut and not liable to sway about, particularly if earthed objects are near.

Types of Aerials.—While, as previously stated, there are many types of aerials or radiating systems, it will be seen that, fundamentally, they are modifications of two distinct systems, namely Marconi and Hertz. The difference between these two methods—and it is advisable to make special note of this for future reference—is as follows. With the Marconi system the aerial is tuned, and the circuit completed by means of an earth, or counterpoise arrangement. It is not necessary to calculate exactly the length of wire, or in other words, an indefinite length of aerial can be used, the whole being brought into tune by means of a coil, or coil and condenser in series.

As an earth or counterpoise is necessary, it is usual to consider the lengths A and E (Fig. 81) when referring to the length of aerial with this system.

The Marconi aerial is not greatly favoured by amateur

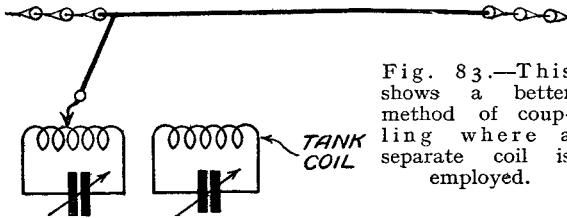

Fig. 83.—This shows a better method of coupling where a separate coil is employed.

stations, except where space is a vital consideration, as it radiates less of its input than the Hertz type.

Hertz Aerial.—With this type of aerial the length is carefully calculated so that its natural frequency or wavelength will correspond to that of the transmitter and/or its harmonics. No form of earth connection is employed, the system being based on the principle that the wavelength to which a wire will tune depends directly upon its length, ignoring, for the moment, certain limitations or secondary factors.

The approximate natural wavelength of a wire is twice its

length in metres, but under operating conditions the exact resonant point is likely to be affected by surroundings.

The length required for any frequency can be determined by the formula:

Length (feet) = $\frac{492,000}{F}$ where F is the *frequency* in kilo-

cycles of transmission. There are, however, other factors which affect the figure, and it is usual to include in the formula K which takes into account the physical properties of the aerial system. For example, on wavelengths between 10 and 80 metres, with wire up to 12 S.W.G. in use for the aerial, and with all earthed objects at least half a wavelength away, K can be taken as

0.95. Thus the formula becomes: Length (feet) = $\frac{492,000}{F} \times 0.95$.

The most simple form of Hertz aerial, and the one most suited to beginners, is known as the "End-on" Hertz, which is

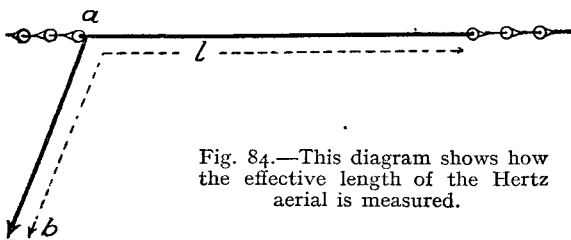

Fig. 84.—This diagram shows how the effective length of the Hertz aerial is measured.

shown in Fig. 82, the aerial being excited by tapping it on to the tank coil of the output valve of the transmitter.

A rather better method of coupling is shown in Fig. 83, where it will be seen that the aerial is tapped on to a tuned circuit, which is inductively coupled to the tank coil.

It must be appreciated that it is possible for a given aerial to be half-wave system on one band, a full-wave on the next higher frequency band, i.e. second harmonic, and so on, but it is not advisable to consider quarter-wave as a loss of radiation efficiency is likely to be experienced. In fact, the most satisfactory results are usually obtained with aerial lengths which are multiples of half-waves, preferably an uneven number.

When considering the length of a Hertz aerial, the full length "l," Fig. 84, must be taken, and when erecting such a system the section a, b should be kept as clear as possible from

earthed objects, otherwise losses due to absorption will be introduced.

The "Zepp" Aerial.—This is a very popular type of aerial which comes within the Hertz group. It obtained its name by the fact that it was widely used, in the early days with the transmitting installations fitted to the Zeppelin airships.

The general arrangement is shown in Fig. 85, where it will



Fig. 85.—The method of connecting the feeders.

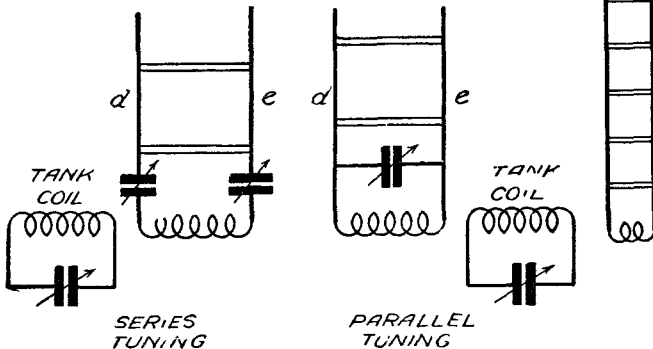

Fig. 86.—Two methods of coupling parallel feeders to the transmitter.

be seen that twin feeders are used, only one of which is connected to the aerial wire, the other terminating at the insulator and left, so to speak, "floating."

The lines or wires, d and e , are known as "feeders," their circuit including the coupling coil, which is inductively coupled to the transmitter. The arrangement is tuned, as shown in Fig. 86, series tuning being usual if the "feeders" are a quarter-wavelength long, and parallel tuning if they are less than a quarter or between three-eighths and half-wavelength in length.

The feeders are spaced by means of rods of insulating

material, the wires being kept 6 in. apart and parallel to each other. It is important to see that d and e are the same length, and that they are not an even number of half-wave long. It is better to make them an odd multiple of a quarter-wave, according to the frequency of the transmitter.

When considering aerial length, the same formula as that given for the "end-on" Hertz aerial can be applied but it should be noted that the length is now only the distance between the extreme ends of the *horizontal* portion, as the feeders, if correctly designed, will not form part of the radiating system.

For 7 mc/s and 14 mc/s transmissions, a horizontal length of 66 ft., with 33 ft. feeders, will be found quite satisfactory.

It is not proposed to discuss here the many other types of aerial systems which are used by amateur transmitters, as the beginner is likely to be more confused than assisted, and, as previously mentioned, one cannot do better than commence operations, that is, if a Full Licence is owned, by employing one of the types mentioned in a previous article on the subject.

Whichever system is used, it is necessary to carry out tests over a reasonable period before condemning or praising the arrangement, as it is not possible to obtain an accurate idea of its performance immediately. If space permits the testing of aerials in various directions, the trouble is well worth taking, as one site will be found which will give better all-round results, although it must be expected that radiations will be weaker in certain directions, due to aerial characteristics and local conditions. A north and south arrangement is usually quite good, providing the feed-end is at the southern point.

Aerial Coupling—"Collins Coupler."—Many coupling arrangements are designed for use with a certain type of aerial, and at a certain frequency. Such methods, while being very efficient under a given set of operating conditions, are often troublesome when it is desired to use some other form of aerial, or transmit on another wavelength. It is in such cases as these that the "Collins Coupler" scores, as it can almost be regarded as a universal arrangement, and one of the most flexible coupling systems known.

Admitted it is a little trouble to make up and adjust in the initial stages, but once it is set for any particular operation it is an easy matter to record such settings for future use.

The theoretical circuit is clearly shown in Fig. 87. It is advisable to include the two fixed condensers C1 and C2, as

they serve the purpose of isolating the coupler and aerial system from D.C. high-tension. They should be of the mica dielectric type, and of a capacity as large as possible. A reasonable capacity—bearing in mind cost—is 0.01 mfd.

The two variable condensers CV1 and CV2 can be between 250 and 500 micro-micro-farads, and for power up to, say, 50 watts they can be of the ordinary *good make* of receiving condenser, but for higher powers properly spaced transmitting types must be used.

The two inductances L1 and L2 are space-wound on a 2½ inch former, tappings being provided every three to five turns.

For frequencies between 1.75 and 14 m.c., inclusive, 30

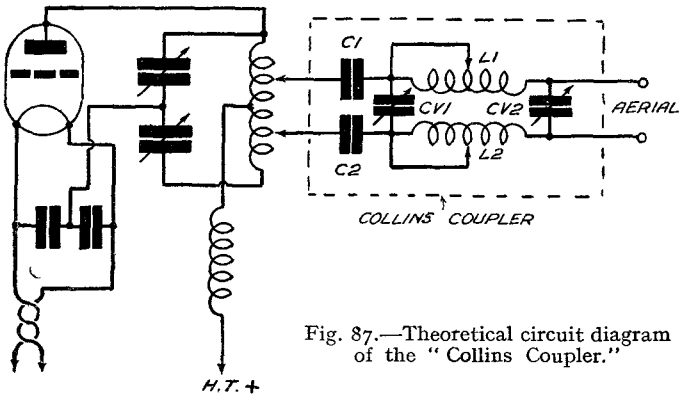

Fig. 87.—Theoretical circuit diagram of the "Collins Coupler."

turns of 16 S.W.G. wire will be required, the winding to take up approximately 5 inches along the former.

As a guide to the setting of L1 and L2 the following number of turns should be in circuit for the frequencies mentioned. The full coil for 1.75 mc/s, 15 for 3.5 mc/s, 10 for 7 mc/s, and 5 turns for 15 mc/s.

Operation.—With the coupler disconnected, the output tank circuit is adjusted for minimum feed, i.e. minimum plate current. The tappings on L1 and L2 are then set for the frequency concerned, and the coupler connected to the tank circuit, the connections being made approximately half-way between the centre tap and the ends of the tank coil.

The condenser CV2 is then set to, say, its mid-position and, with the transmitter running, adjust CV1 for minimum feed

again. Should it happen that the resonance point is not found throughout the rotation of CV1, try another setting for CV2, and should that fail to bring about the desired conditions, fresh adjustments must be made to the tappings on L1 and L2.

It should be noted that when a two-wire feeder is used, the number of turns of L1 and L2 in circuit must be identical, and once the tank circuit has been adjusted to resonance with the coupler disconnected, it should not be touched.

Aerial Suspension.—The station owner who possesses a large garden, free from large trees and other earthed objects, is very fortunate, as he is then in the happy position of being able to swing the aerial through many points of the compass and try out systems which the less fortunate owner cannot do through lack of space. A considerable amount of interest and information can be gained through such experiments, even with a low-powered output, especially if several wavebands are worked.

While one's activities are often cramped by the lack of ground space, it does not always follow that all parts of the aerial system have to suffer accordingly; for example, the construction and measurement of the electrical path can be made as perfect as possible, particular attention paid to all insulation, and an item which is very important, viz., height. The first of these calls for care in calculating the exact length, according to type of aerial and waveband operated, the selection of good wire of reasonable diameter, and arranging matters so that joints are eliminated. If, however, circumstances force them to be made, make sure that good soldered connections are used only, and do *not use* spirit for the soldering flux. The joint should always be bound with electrician's black insulating tape to protect it from the weather.

As regards insulation, too much attention cannot be paid to this item. Be generous with the use of insulators. The large shell or barrel types are far superior to the very small egg type. Better still, use some of the light corrugated insulators which are specially designed for such work.

If guys are used with the mast, especially if they are of wire, always insert insulators in each one, say, six feet from the mast end. The barrel type are most suited for this, providing, of course, that they are fastened in the proper manner.

Height of Masts.—Metal masts possess the advantages of strength and neatness, but unless space permits the effective portion of the aerial to be well away from the mast, and unless

a high-powered outfit is being used, the average amateur cannot do better than use some form of wooden support.

Scaffold Poles.—These provide one of the cheapest forms of support, and, if properly selected and treated, one of the neatest and simplest.

When selecting the timber, pick one that is straight with a gentle taper to the top end, the diameter depending on its

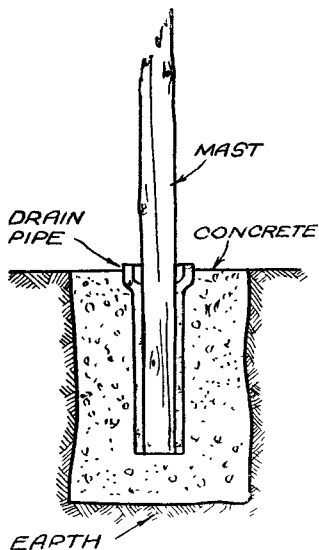
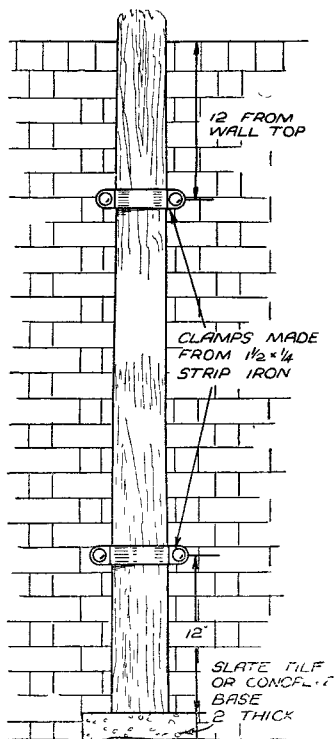

Figs. 88 and 89.— (Left) Method of bolting an aerial pole to a wall. (Above) When the mast is to be buried in the earth this arrangement will prevent rotting.

height. For a thirty-foot pole, 13 ins. round the base is ample, otherwise it will tend to look very clumsy. After the bark has been removed, smooth off all knots, and if time and weather permit, allow a few days for it to dry out before putting on the first coat of paint. If it is desired to paint it,

three coats of good outside paint will be necessary, but if on the other hand a brown colour is not objected to, one cannot do better than apply a good coating of creosote or other wood preservative.

Fixing Methods.—The actual method of fixing depends on available conditions and where it is not possible to use a wall, as in Fig. 88, the alternatives, Fig. 89 and Fig. 90, are the most satisfactory. Referring to Fig. 89, it must be remembered that the effective height will be reduced by the amount that is let into the ground; therefore, the arrangement, shown in Fig. 90 is preferable as it also has the advantage of allowing the mast to be lowered to the ground again easily should it be necessary for repainting or fitting fresh tackle.

With a thirty-footer, guys are not usually required, providing the base fixing is really secure, but for greater heights they are very essential, and care should be taken in placing them and adjusting their tension.

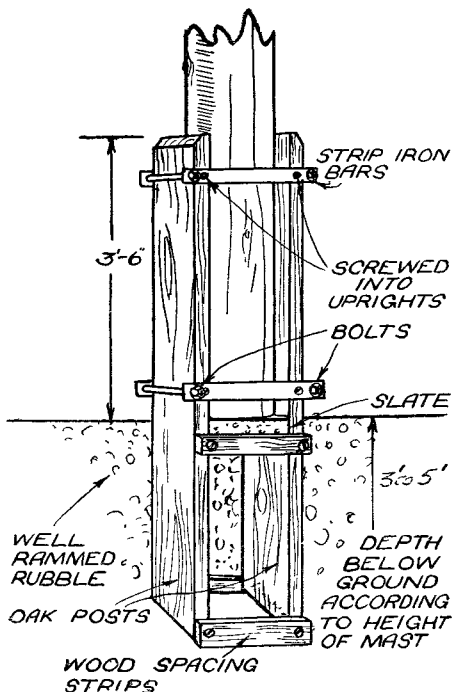

Fig. 90.—To enable the mast to be lowered adopt the scheme shown here.

As it is not always easy to obtain a single pole having a height of 40 to 45 feet, it becomes necessary to join two suitable poles together when such heights are required.

While such procedure is quite satisfactory if the joints are properly made, it should be noted that careless fixing and slap-dash methods can make such an arrangement very dangerous, so it is up to

the constructor to pay particular attention to the matter, and satisfy himself that all is well as regards the material used and the method adopted.

If the ideas outlined in Fig. 91 are followed a safe and neat job will be obtained, producing a mast of 45 to 50 feet according to the length of the individual sections.

All the necessary tackle can be obtained from any ship's chandler, rope merchant, or large ironmonger's stores, and it is well worth the slight additional cost to obtain the correct and essential fittings.

When a top mast is used, as in Fig. 91, it is advisable to take guys—three will be sufficient—to the top clamp, and one to the top of the top mast to counteract the pull of the aerial. When deciding on anchoring points for the guys, do not make the angle too acute, and don't forget to see that the anchoring points are *really* secure, otherwise they are more than useless.

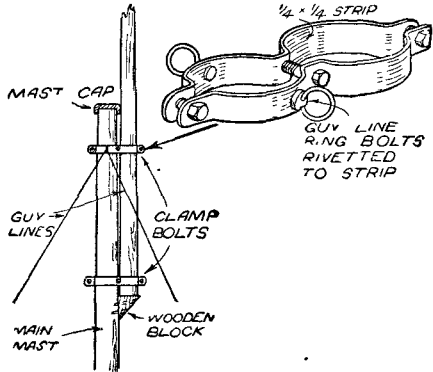

Fig. 91.—To obtain additional height an extension piece may be attached in this manner.

The latticemast now dealt with is exceptionally light, easy to handle and erect, very strong, and adds a very businesslike look to the station.

It is thirty feet in height, but there is not the slightest reason why it should not be forty or forty-five feet; and it can be built in about forty hours at the outside.

The main framework is constructed from $\frac{3}{4}$ in. square finished straight grained pine, the wood being supplied in 10 ft. lengths. The lattice work is carried out with selected lathing, which can also be obtained in the same length. This, however, is not important as each single piece of lathing used is much shorter than 10 ft.

For ease of construction, the mast is constructed in three sections, Figs. 92, 93 and 94, provision being made for them to be screwed together on completion.

The diagrams are self-explanatory, while the illustration gives some idea of the appearance of the finished job. It will be noted that guys were used, but providing the base of the

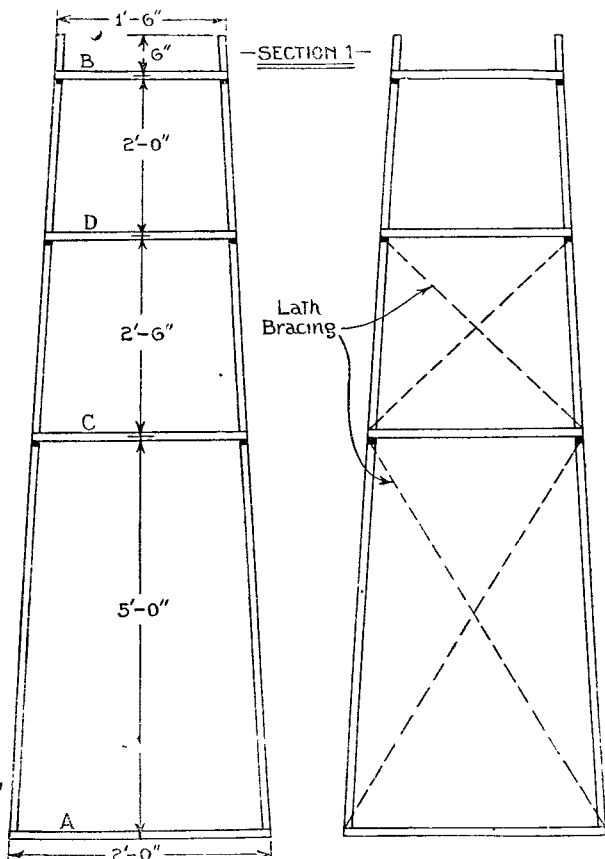

Fig. 92.—Method of building the first section and fixing cross-bracing strips.

mast is securely anchored to a prepared bed, say, concrete, they are quite unnecessary.

Hoisting Masts.—The hoisting of masts can often prove a

and metal tubular types, it is often necessary to adopt the arrangement shown in Fig. 96, otherwise "whip" will be experienced, which, if it once gets beyond the control of the hoisters, can prove most awkward and dangerous. When erecting such masts, it is essential to have at least four helpers, one hauling, one taking the strain in the opposite direction, and one for each side guy.

It is in this direction that the lattice mast scores as it is so easy to erect, two men being able to do the job quite comfortably.

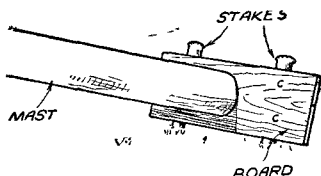

Fig. 95.—An easy way of obtaining the leverage necessary to erect a pole in the garden.

There is one point to watch. When the mast is in the vertical position but before the guys are anchored, don't, if you are the one holding the base of the mast while the others see to the guys, look up the mast, as the slightest movement creates the impression that the whole lot is going to topple over and causes much unnecessary apprehension and undue strain. It is quite unnecessary to haul the guys really tight; just take up the strain and leave for a couple of days until they have stretched, and the mast has settled down; then go over everything and make final adjustments.

If any doubt is placed upon the aerial supporting rope, some arrangement should be made to facilitate its replacement without having to lower the mast or pole.

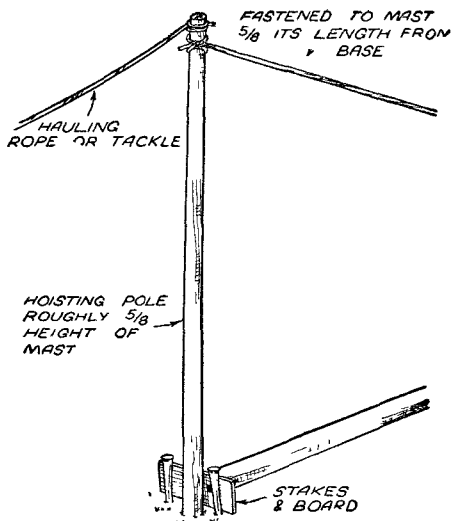

Fig. 96 —An alternative method of putting up the mast where space is restricted.

CHAPTER XI

STATION LAYOUT

MANY beginners are so anxious to carry out tests, as soon as they have completed the assembly of the essential apparatus of a transmitting station, that they do not stop to give the actual planning of the station any consideration, with the result that they are often disappointed with their initial tests and the absence of contact reports.

While fully appreciating that all of us are subject to such impatience, it is a procedure that should not be encouraged, as apart from the question of loss of efficiency there is also the question of risk to the operator and, of course, other people in the house, so if hook-up tests are made, always make quite sure that everything is left well protected, and all mains gear rendered absolutely *dead*, as soon as the tests are completed. The best way, and the one which should be adopted right from the start, is to plan the station before commencing any constructional work.

Location of Gear.—One of the first things to be settled is where is the apparatus going to be used.

If one is not already the fortunate possessor of a private spot wherein all radio work can be carried out without disturbing the rest of the household, it will be necessary to start looking round the house or garden for a suitable spot which can be commandeered without causing trouble in the domestic sphere. Many stations are housed in a shed, shack or workshop in the garden and such an arrangement is often highly satisfactory, assuming that the structure is perfectly weather-proof, fitted with mains supply and provided with some form of heating. It is, of course, a great asset if the shed is so placed that the aerial feeders can be taken in without difficulty or obstruction. There are one or two points to watch with such accommodation. See that the floor is of such a nature that it is not damp; if there is any tendency in that direction, it is quite an easy matter to make "duck boards" to stand on, thus reducing the possibility of nasty shocks from the H.T. and mains gear. Ample light is also another very desirable feature, while a good lock should always be fitted to the door.

The supply mains should be connected to a small "iron clad" double-pole/double-throw switch, equipped with fuses close to the point where they enter the shed, thus allowing a master control to be provided for all electrical wiring (mains) used for the installation. Do not on any account allow the wiring to be of the "hook-up" style; use conduit or lead-covered twin wire, and see that a proper job is made of all fittings and switches. If the apparatus has to be housed indoors, there are many spots which can be quite easily converted into a comfortable "den"; for example, quite a lot of serious work can be carried out in a loft, old lumber room, attic, or large cupboard, while certain cellars and basements must not be overlooked as a last resource. With flat dwellers the position is not always so easy, as space is often the controlling factor. However, where there is a will there is usually a way, and some existing piece of furniture, say, a cabinet, desk, or cupboard can usually be found to house the gear.

Of course, where conditions permit the sole use of a room for one's activities, everything is simplified considerably, providing that it is not situated so that annoyance will be caused to other members of the household when the station is operating during the late hours of the night, and the early hours of the morning.

It is not possible to lay down any hard and fast rules concerning this, but the fact should not be overlooked that many hours will be spent "on duty" and it is essential, for that reason, that adequate light and ventilation are provided, while some means of controlling the temperature, both winter and summer, are equally vital. If it is a question of choosing between space and the comforts mentioned above, then the latter should receive the deciding vote, as it is impossible to concentrate and do serious work under uncomfortable conditions.

Although there are no very definite rules concerning the layout and arrangement of all the gear, as so much depends on facilities available and general conditions.

The Transmitter.—The actual location of the transmitter proper will be governed by the position of the feeder lines, but it is advisable to fix it up on a stout shelf within reach, if possible, of the operating table or desk.

Power Equipment.—The mains unit is best housed in a stout metal case or cover and placed well away from the transmitter, speech amplifier and "mike" equipment. It should be in a readily accessible spot and yet out of harm's way. A very

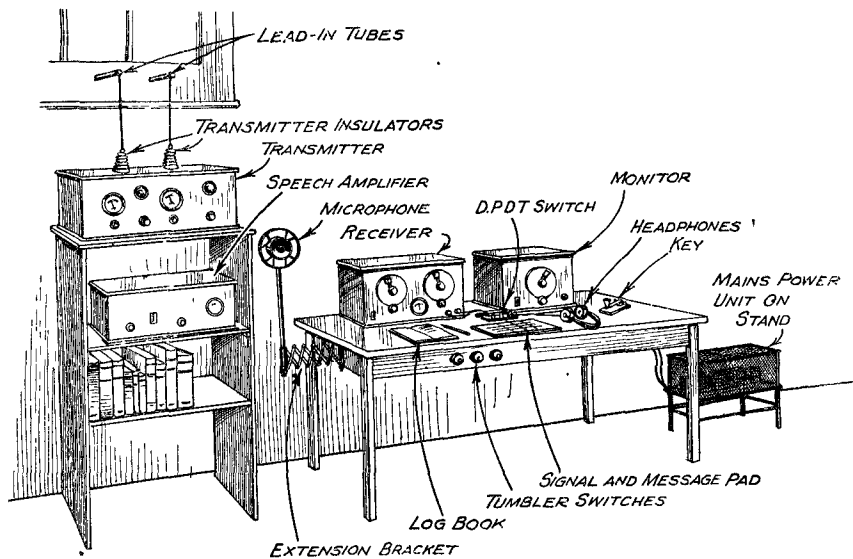

Fig. 97.—Suggested arrangement of the amateur transmitter's "den" to provide efficiency and comfort.

good idea is to stand it on a firm stand about a foot off the floor and to one side of the operating table.

Operating Table or Desk.—This should consist of a stout table, shelf or desk to which can be fixed the operating key, control switches and pilot lamps, and on which can rest the receiver, monitor, measuring instruments, log book, pads, and headphones or speaker. An ordinary white wood kitchen table, with the top covered with plain brown or green lino is very satisfactory, as one is then not afraid of using holding down screws where necessary.

It is essential that the key is placed to allow ample rest room for the arm, while space must also be allowed for the unrestricted use of the log book and signal pads.

The diagram, Fig. 97, shows the idea, and the suggested position of the switches, one of which should be for the control of mains supply. The others will depend on circuit requirements, but it is a good idea to embody a D.P./D.T. type for changing the headphone over from receiver to monitor, while another will be necessary for microphone and/or key.

Full or A.A. Licence.—It might be thought that all these details apply only to a "full" licence station, but that is not the case, as it is equally, if not more so, important for the beginner or A.A. man to take a good deal of trouble over the layout and methodical operation of his equipment, otherwise he will never get the full benefit of his licence. After all, it does not matter whether the output is 1 or 100 watts, the main interest and pursuit is the same, namely, to obtain the maximum efficiency from the gear in use and that applies to each individual part of the station from the power switch to the aerial and its supports.

CHAPTER XII

FREQUENCY METERS

ALTHOUGH the G.P.O. Regulations do not state that a frequency meter is essential, when a crystal-controlled transmitter is employed it is one item which should form part of the equipment of every station.

They are not expensive things to make up, neither does the construction involve a lot of work ; the only part requiring a reasonable amount of patience and care is the actual calibration. However, that is not so difficult as it would first appear.

There are several types of frequency meters, each, apparently, having outstanding claims, so it is up to the constructor to select the one most suitable for his work, and according to the parts available.

Absorption Method.—The most simple arrangement is, undoubtedly, that making use of absorption, and which consists of nothing more complicated than a straightforward tuned circuit.

The fundamental circuit is shown in Fig. 98. The grid coil B is coupled to the circuit under test which, in the case of a transmitter is the generator of oscillations, or in other words, the oscillator, and tuned by the condenser C until the maximum power is absorbed. When such a state exists, the circuit C.L. will be tuned to the same frequency as the oscillator.

It is usual to provide some visual means whereby it is possible to tell easily, when the two circuits are in resonance. A suitable neon lamp across the condenser C or a small pocket lamp bulb in series with L is quite satisfactory, only the latter method has the disadvantage of making the tuning rather flat.

A better arrangement is shown in Fig. 99 where it will be seen that a separate winding is used for the lamp, the winding L₁ being inductively coupled to L. This does not increase the resistance of L.C. and, therefore, allows very much sharper tuning to be obtained. On test, the difference is quite marked.

Choice of Coils.—It is not necessary to wind special coils, although if the constructor desires to do so he can obtain all the data he requires from standard S.W. coils, and it is suggested that ordinary four pin plug-in S.W. coils—with

reaction winding—are used, providing they are of good make and accurate so far as their wave-band coverage is concerned.

There is one point which might need attention. The distance between reaction and grid windings may need reducing, but that all depends on individual conditions, and must, therefore, be left as a matter for experiment.

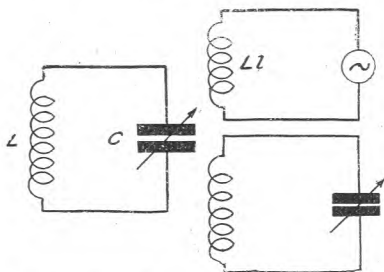

Figs. 98 and 99.—Circuit diagrams of an absorption type frequency meter.

motion drive. Select that type which gives the greatest turns ratio with the smoothest drive.

The calibration can be carried out in conjunction with any S.W. receiver—preferably of the straight type—which is

When the meter circuit is in resonance with the circuit under test the lamp will give the maximum brightness; the power absorbed may stop the oscillator oscillating, and cause an increase in the anode consumption of the valve.

It is, of course, vitally necessary that the meter is calibrated accurately, and the condenser C fitted with a really good *slow*

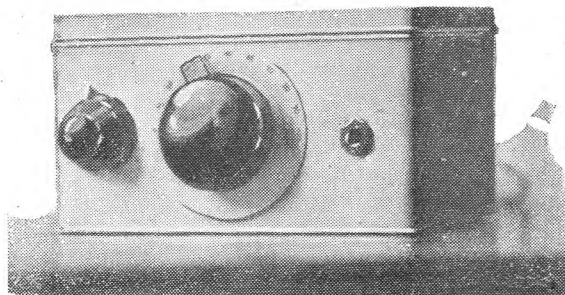

Fig. 100.—A general view of the frequency meter, showing the two controls and 'phone jack.

capable of receiving a good number of commercial S.W. stations whose frequency of transmission is known. Each coil, i.e. each wave range must be calibrated, so it may be

necessary to spend some little time on this part of the business. Simple tuning charts, providing they are plotted with care, are all that are necessary to determine the frequency for any coil at any given setting of C.

An Electron-coupled Frequency Meter.—The apparatus required is very simple and inexpensive, consisting of a valve oscillator and accompanying tuning arrangements. In the design of such a unit there are several points which must be noted, namely: (i) complete stability with inclusion of good

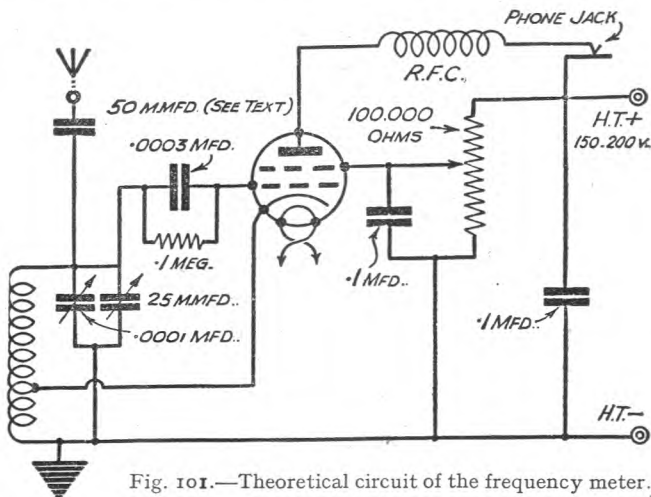

Fig. 101.—Theoretical circuit of the frequency meter.

components for accurate calibration ; (ii) complete rigidity and constant voltage regulation ; and (iii) inclusion of means for monitoring the transmitter.

In Fig. 100 will be seen a general view of the unit, which consists of a screening box with tuning and regeneration controls, and the monitor 'phone jack. The circuit, Fig. 101, consists of an electron-coupled oscillator, which incorporates to the best advantage all the points enumerated above. The 3.5 megacycle band is used as fundamental, as it is very stable, and also gives the best harmonics on the higher frequencies. An A.C. mains valve is used, as it affords an easy means of electron coupling, and voltage regulations are more reliable with this valve than with a battery type.

reaction winding—are used, providing they are of good make and accurate so far as their wave-band coverage is concerned.

There is one point which might need attention. The distance between reaction and grid windings may need reducing, but that all depends on individual conditions, and must, therefore, be left as a matter for experiment.

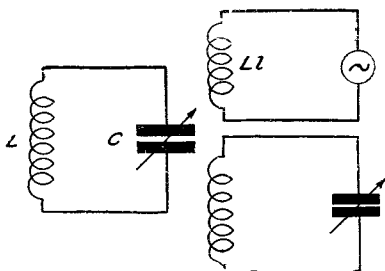

Figs. 98 and 99.—Circuit diagrams of an absorption type frequency meter.

When the meter circuit is in resonance with the circuit under test the lamp will give the maximum brightness; the power absorbed may stop the oscillator oscillating, and cause an increase in the anode consumption of the valve.

It is, of course, vitally necessary that the meter is calibrated accurately, and the condenser *C* fitted with a really good *slow*

motion drive. Select that type which gives the greatest turns ratio with the smoothest drive.

The calibration can be carried out in conjunction with any S.W. receiver—preferably of the straight type—which is

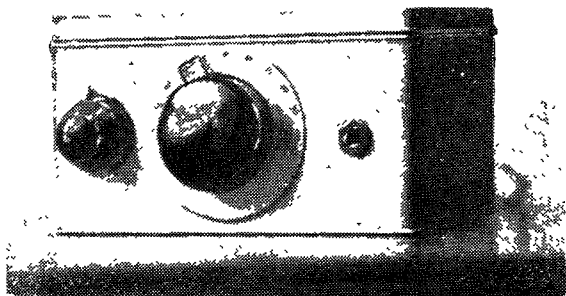

Fig. 100.—A general view of the frequency meter, showing the two controls and 'phone jack.

capable of receiving a good number of commercial S.W. stations whose frequency of transmission is known. Each coil, i.e. each wave range must be calibrated, so it may be

necessary to spend some little time on this part of the business. Simple tuning charts, providing they are plotted with care, are all that are necessary to determine the frequency for any coil at any given setting of C.

An Electron-coupled Frequency Meter.—The apparatus required is very simple and inexpensive, consisting of a valve oscillator and accompanying tuning arrangements. In the design of such a unit there are several points which must be noted, namely: (i) complete stability with inclusion of good

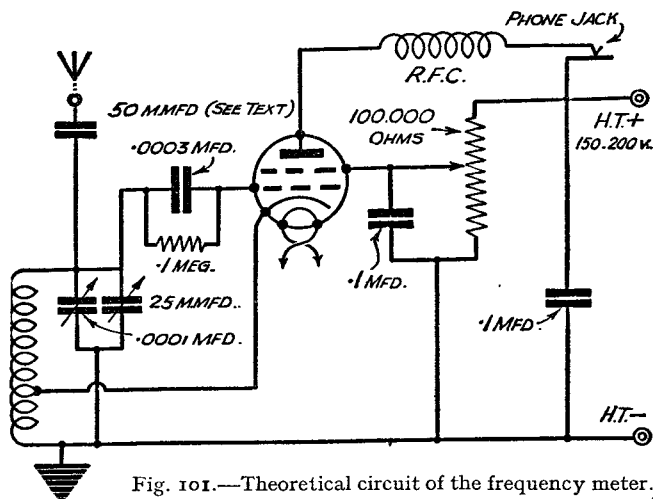

Fig. 101.—Theoretical circuit of the frequency meter.

components for accurate calibration; (ii) complete rigidity and constant voltage regulation; and (iii) inclusion of means for monitoring the transmitter.

In Fig. 100 will be seen a general view of the unit, which consists of a screening box with tuning and regeneration controls, and the monitor 'phone jack. The circuit, Fig. 101, consists of an electron-coupled oscillator, which incorporates to the best advantage all the points enumerated above. The 3.5 megacycle band is used as fundamental, as it is very stable, and also gives the best harmonics on the higher frequencies. An A.C. mains valve is used, as it affords an easy means of electron coupling, and voltage regulations are more reliable with this valve than with a battery type.

LIST OF COMPONENTS

One screening box, 7 in. by 5 in. by 4 in.
 One 25 mmfd. variable condenser, type 1045 (Eddystone).
 One 100 mmfd. pre-set condenser (Formo).
 One .0003 mfd. mica condenser (Dubilier).
 Two .1 mfd. tubular condensers (T.C.C.)
 One 5-pin valveholder (W.B.).
 One 4-pin valveholder, type 1015 (Eddystone).
 One .1-megohm gridleak (Erie).
 One .1 meg. potentiometer (Dubilier).
 One H.F. choke, type 1010 (Eddystone).
 One plug and jack (Igramic).
 One coil former (Eddystone).
 Two midget stand-off insulators (Eddystone).
 One valve, type S4VB (Mullard).
 Screws, wire, systoflex, etc.

General Arrangement.—A general view of the interior of the unit is given in Figs. 102 and 103, from which it will be seen that the valve is placed in a horizontal position, while the coil is also horizontal but at right angles to the valve. The coil is tuned by a .0001 mfd. pre-set condenser which acts as band-set, and an Eddystone type No. 1045 bandspread condenser with integral slow motion.

Regeneration is controlled by a .1 megohm potentiometer which varies the screen voltage. If a metallized valve is used care must be taken that it does not touch the box, for should it do so the cathode tap would be shorted and oscillations would cease. The grid condenser, the connections for which are less than $\frac{1}{2}$ in. long, is of .0003 mfd. capacity, with a .1 megohm gridleak across it. A single closed jack has been included in the plate circuit, with an H.F. choke in series. When a pair of 'phones are inserted in this, the unit acts as a monitor. Two .1 mfd. by-pass condensers are included, one from the screened grid to earth, and the other across the H.T. supply.

Provision has been made for a short piece of wire to act as a pick-up for higher frequencies or transmitter carrier, and this is connected to the set through a very small capacity condenser, consisting of a few turns of wire wound round a wire covered with systoflex, attached to the grid end of the coil. This is brought out to a midget insulator on the back of the box, as is also an earth connection.

The coil consists of 26 turns of 22-gauge enamelled wire on an Eddystone threaded former, with the cathode tap at the sixth turn.

Operating Details.—

Using a valve such as the Mullard S4VB, and about 150 to 200 volts on the plate, the potentiometer about half-way, and the unit placed a few feet from the receiver which is tuned to 40 metres, a beat note should be found when the pre-set is turned. This condenser is mounted, it will be noticed, some way off the box by means of insulating washers. Having found this beat, the pre-set should now be

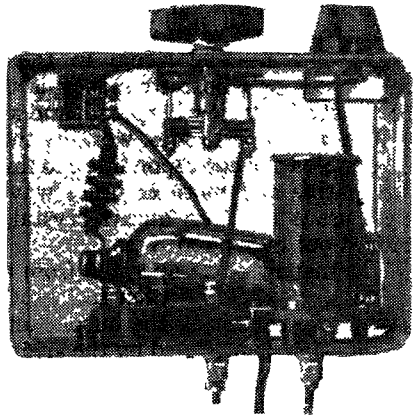

Fig. 102.—View of the interior of the meter showing the valve and coil in position. The by-pass condensers have been omitted.

adjusted until, with the lid on the box and the band-spread condenser set between 0 and 15 degrees, the beat comes in at the H.F. end of the 40-metre band. The receiver is now set at a known frequency in the 40-metre band and the meter

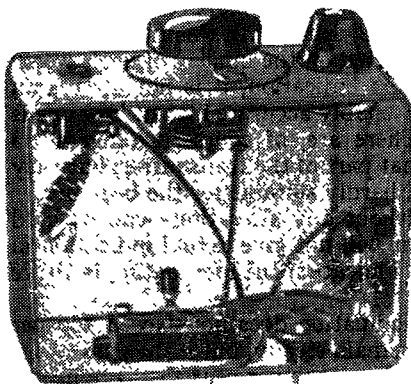

Fig. 103.—The short grid leads will be seen in this illustration, which also shows the band-set pre-set condenser.

band-spread adjusted until the beat is again heard. This new reading is noted, a new known frequency on the receiver is taken, the meter brought into line, and its reading again noted. This process is repeated until enough points have been found to form a graph of frequency against dial readings on the meter. As has already been mentioned, it may be found that a short wire will have to be connected

LIST OF COMPONENTS

One screening box, 7 in. by 5 in. by 4 in.
 One 25 mmfd. variable condenser, type 1045 (Eddystone).
 One 100 mmfd. pre-set condenser (Formo).
 One .0003 mfd. mica condenser (Dubilier).
 Two .1 mfd. tubular condensers (T.C.C.)
 One 5-pin valveholder (W.B.).
 One 4-pin valveholder, type 1015 (Eddystone).
 One .1-megohm gridleak (Erie).
 One .1 meg. potentiometer (Dubilier).
 One H.F. choke, type 1010 (Eddystone).
 One plug and jack (Igranic).
 One coil former (Eddystone).
 Two midget stand-off insulators (Eddystone).
 One valve, type S4VB (Mullard).
 Screws, wire, systoflex, etc.

General Arrangement.—A general view of the interior of the unit is given in Figs. 102 and 103, from which it will be seen that the valve is placed in a horizontal position, while the coil is also horizontal but at right angles to the valve. The coil is tuned by a .0001 mfd. pre-set condenser which acts as band-set, and an Eddystone type No. 1045 bandspread condenser with integral slow motion.

Regeneration is controlled by a .1 megohm potentiometer which varies the screen voltage. If a metallized valve is used care must be taken that it does not touch the box, for should it do so the cathode tap would be shorted and oscillations would cease. The grid condenser, the connections for which are less than $\frac{1}{2}$ in. long, is of .0003 mfd. capacity, with a .1 megohm gridleak across it. A single closed jack has been included in the plate circuit, with an H.F. choke in series. When a pair of 'phones are inserted in this, the unit acts as a monitor. Two .1 mfd. by-pass condensers are included, one from the screened grid to earth, and the other across the H.T. supply.

Provision has been made for a short piece of wire to act as a pick-up for higher frequencies or transmitter carrier, and this is connected to the set through a very small capacity condenser, consisting of a few turns of wire wound round a wire covered with systoflex, attached to the grid end of the coil. This is brought out to a midget insulator on the back of the box, as is also an earth connection.

The coil consists of 26 turns of 22-gauge enamelled wire on an Eddystone threaded former, with the cathode tap at the sixth turn.

Operating Details.—

Using a valve such as the Mullard S4VB, and about 150 to 200 volts on the plate, the potentiometer about half-way, and the unit placed a few feet from the receiver which is tuned to 40 metres, a beat note should be found when the pre-set is turned. This condenser is mounted, it will be noticed, some way off the box by means of insulating washers. Having found this beat, the pre-set should now be

adjusted until, with the lid on the box and the band-spread condenser set between 0 and 15 degrees, the beat comes in at the H.F. end of the 40-metre band. The receiver is now set at a known frequency in the 40-metre

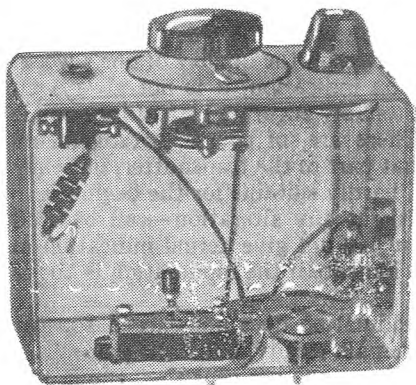

Fig. 103.—The short grid leads will be seen in this illustration, which also shows the band-set pre-set condenser.

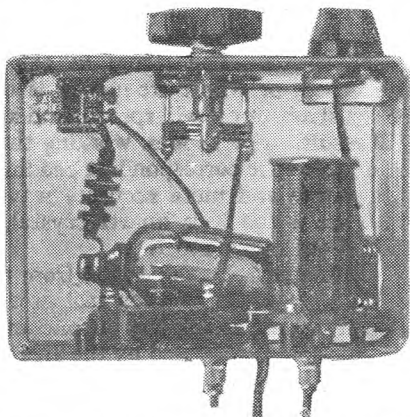

Fig. 102.—View of the interior of the meter showing the valve and coil in position. The by-pass condensers have been omitted.

band-spread adjusted until the beat is again heard. This new reading is noted, a new known frequency on the receiver is taken, the meter brought into line, and its reading again noted. This process is repeated until enough points have been found to form a graph of frequency against dial readings on the meter. As has already been mentioned, it may be found that a short wire will have to be connected

to the aerial terminal on the meter to transfer R.F. from the meter to the set when using it on the higher frequency bands.

Calibration.—The signal in the receiver which is to be calibrated, or whose frequency is to be measured, must not be too strong, or it will spread, and an inaccurate measurement will result. For 14 Mcs. working the frequencies have only to be doubled for corresponding readings on the meter dial. An alternative and more accurate way of calibrating this meter is to use a 100 Kcs. quartz crystal, whose harmonics can be picked out every 100 Kcs.

The meter can be operated from the receiver power supply.

Monitor and Modulation Indicators.—A simple and effective means of monitoring the output and keeping a check on the modulation, is provided by the arrangement shown in Fig. 104. The coil and condenser combination is chosen to suit the wave-band concerned, though there is no reason why standard plug-in S.W. coils should not be used, thus making its use more general. It is necessary to lightly couple the coil to the transmitter, but care must be taken to see that rectified current does not exceed, say, 0.2 mA., or that specified by the makers of the rectifier, by making the coupling too tight.

Headphones can be connected by terminals or plug and jack. Personally, the latter arrangement is the better, especially if it is made standard throughout the station equipment.

The milliammeter M should have a maximum reading of, say, 1 mA. or 1.5 mA., the former being the better, and it is essential for the meter to be efficient. With this piece of apparatus, a check can be maintained on the quality of one's work.

With regard to modulation indication, it is not always an easy matter to obtain a reasonably accurate idea of how one is modulating the carrier. There are, of course, arrangements for checking the effect of that part of the transmitter, but they are rather complicated and hardly suitable for the beginner.

The monitor shown—without any alteration—can be used for such work, and, while it will not give actual indication in terms of percentage, it will indicate if the modulation is above or below 100 per cent.

If all is in order, and modulation does not exceed 100 per cent. the meter needle will remain steady, but if the percentage of modulation is increased above 100 per cent then the needle starts to kick upwards, and adjustments are called for.

It will be remembered that over modulation can be responsible for radiation over a very wide wave-band, thus causing

interference to nearby receivers, therefore, it is a point which must be watched.

Another very efficient piece of apparatus is shown below, and an examination of the circuit diagram, Fig. 105, will show that it is nothing more than a detector and L.F. amplifier, using a double diode triode across a

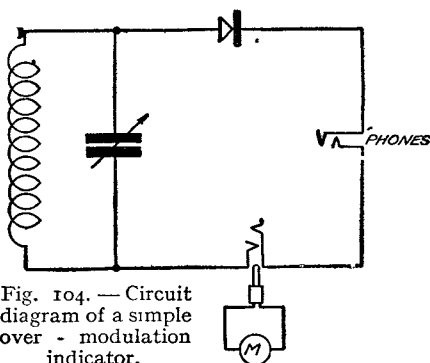

Fig. 104. — Circuit diagram of a simple over - modulation indicator.

plain tuned circuit. The headphones are connected between the output condenser and earth, no D.C. flowing in this circuit. It is essential that headphones are used, as feed-back into the " mike " circuit will be obtained if a loudspeaker is used.

- R1—60,000 Ohms.
- R2—.5 Meg.
- R3—1 Meg.
- C—.01 Mfd.
- C1—.0001 Mfd.
- C2—2 Mfd.
- C3—.1 Mfd.

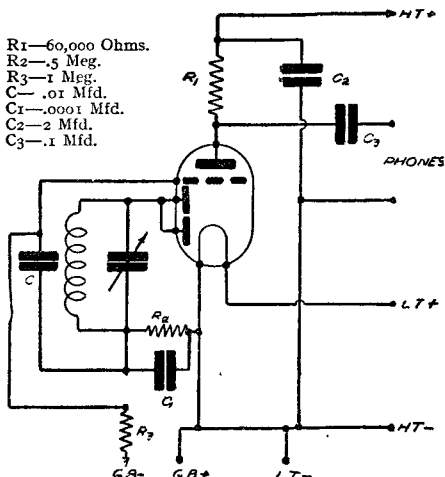

Fig. 105.—A simple headphone monitor.

The tuned circuit is properly designed, as a frequency check. The layout is not critical, but it should be built as a self-contained unit, whether batteries or mains are used. Although batteries are looked upon by many as being rather troublesome, they do possess the advantage of dead silent operation, a rather valuable feature in a rig of this type.

The tuned circuit can be formed with any suitable coil and condenser combination, the frequency of the transmitter comes within the tuning band.

It will be found that the arrangement is quite sensitive, and that ample output is provided to enable accurate checks to be made on the quality of transmission, modulation experiments, adjustments, hum and other undesirable noises, while it will also serve, providing the

CHAPTER XIII

H.T. SUPPLIES

ONE item which is so often the bugbear of would-be transmitters is the adequate supply of high-tension current.

Fortunately for the beginners of to-day, the problem is not so serious as it was in the early days when conditions necessitated the use of hand generators, racks of cells or piles of dry batteries, all of which did not lend themselves to ideal operation or economical upkeep.

Now that the efficiency and range of available valves have reached a stage far beyond the pioneers' wildest dreams, it is possible to obtain quite good worthwhile range with cells or dry batteries, thus allowing the less fortunate enthusiasts who are without mains supplies to enter the transmitting circle.

The limiting factor with cells and dry batteries is not so much a matter of voltage, but current, and if one is forced to use either of these sources of H.T. supply it is vitally important to design the outfit to operate with the minimum possible current consistent with wattage desired. Actually the problem should be considered the other way round—assuming upkeep cost to be an important factor—and limit the choice and design of the circuits by the source of H.T. available.

Large-capacity H.T. accumulator blocks are, of course, more satisfactory than dry cells, but if the station is situated in the country many miles from the nearest charging plant, then fresh complications are introduced.

The cells which are rechargeable from a six-volt accumulator offer some solution to the problem, as it is far easier to arrange transport for a single six-volt accumulator than for, say, several trays of smaller cells.

Rotary converters, operating from 6 or 12 volt accumulators, provide the nearest approach to A.C. mains, as they can be obtained with quite large wattage outputs; they are compact and reliable, and if reasonable care is taken with their housing and smoothing arrangements they are interference free.

An even better method of supply—at least so far as rendering the user absolutely independent of any form of charging—is the small petrol-driven A.C. generator which is now on the market for radio and P.A. work. It is capable of delivering

300 watts A.C. and 50 watts D.C., the latter being suitable for charging if so desired. One of these petrol-driven units is shown in Fig. 106.

The initial cost of the last two methods is, of course, rather on the high side for the average amateur, but if serious prolonged work is contemplated then they would become an economical investment.

Mains Supplies.—Where electricity supplies are available, the whole problem—to all intents and purposes—is solved, as adequate power can be obtained at a cost far below that of

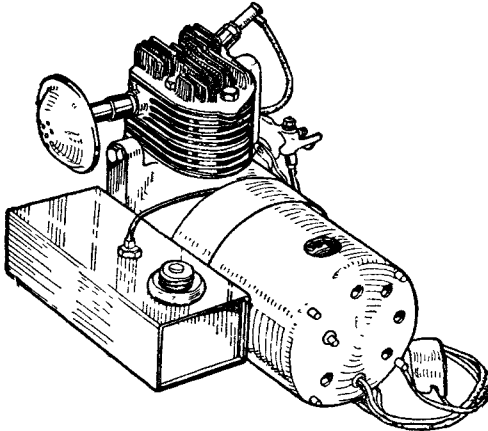

Fig. 106.—A small petrol-driven generator with an output of 200 watts.

other means, and, in the case of A.C., the voltage can be increased or decreased by the use of a simple transformer to meet the needs of the apparatus in use.

D.C. Supplies.—The average direct current supply is ideal for a low-power outfit. It presents a source of power which, comparatively speaking, is ready for use, but—and this is the reason why the stipulation “low-power” is used—the voltage is invariably between 200 and 250 volts. If a higher voltage is required, then, unlike A.C., it becomes necessary to use a generator involving, of course, additional heavy expense. Although the supply is of a direct current nature, on no account must it be connected to the transmitter direct. However good the supply, there is bound to be a slight ripple present and

it is absolutely essential for all trace of that to be removed before applying the feed to the H.T. circuits.

Fortunately, the procedure is not elaborate or expensive, the arrangement shown in Fig. 107 usually being sufficient. The choke Ch is of the L.F. type having an inductance between 5 and 10 henries *when* the total required current is flowing. Depending on the nature of the mains, it is sometimes an advantage to wire the choke in the negative lead or, better still, insert one in each side of the mains, as shown in Fig. 108.

It must be remembered when dealing with D.C. mains that

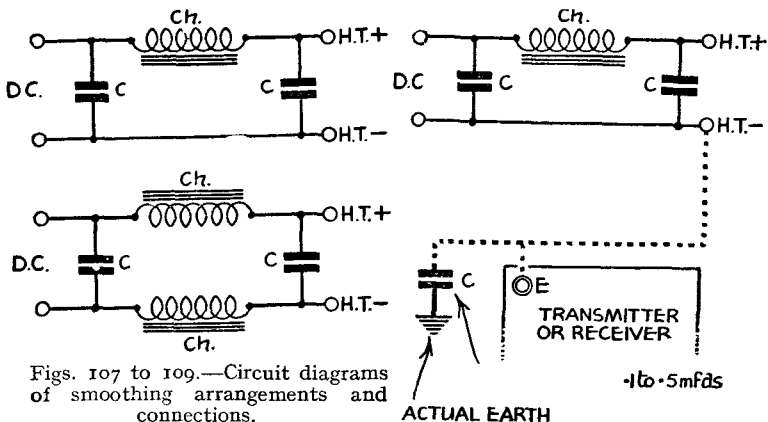

Figs. 107 to 109.—Circuit diagrams of smoothing arrangements and connections.

the negative side must *never* be connected *direct* to earth, as one side of the mains is always earthed and it might be the positive, in which case a short circuit would be produced if the negative were not isolated from the earth terminal of the transmitter. It is usual and necessary—the same as with D.C. receivers—to insert a non-inductive condenser between the actual earth and the earth terminal, as shown in Fig. 109.

As direct connection is being made to the mains for the H.T. supply, adequate switching arrangements and fuses should always be embodied. A double-pole single-throw switch should be connected between the mains and the fuses, thus allowing the transmitter circuit and fuses to be rendered "dead" when the occasion arises.

Alternating Current.—Although the use of alternating current involves greater initial costs, it has definite advantages

over D.C. It can, for example, be stepped up or down according to requirements, so making its application much wider or more flexible than the fixed maximum value of direct current supplies. The only disadvantage—if it can be considered as such—of A.C. mains is that it is necessary to provide some

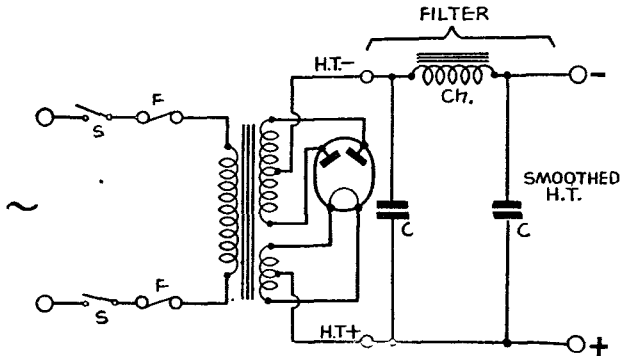

Fig. 110.—Circuit diagram of a full-wave valve rectifier.

means to rectify the alternating current into a steady, ripple-free direct current.

This can be carried out by the use of valve or metal rectifiers, typical examples of the methods being shown in Figs. 110 and 111. While it is, of course, vitally important to see that the

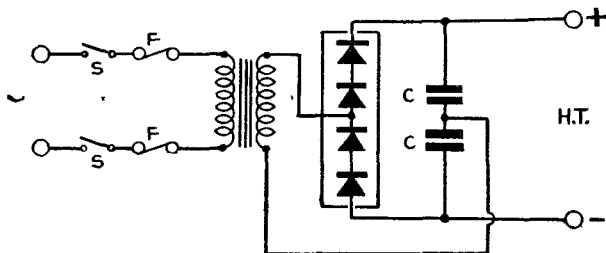

Fig. 111.—Diagram showing a metal rectifier used in a voltage-doubler circuit.

mains transformer is really good in an electrical and engineering sense; that it is designed for the rectifier concerned, and that both are capable of supplying the output required, it is

also of vital importance to pay particular attention to the smoothing of the rectified current.

Rectified A.C. requires more smoothing than the normal D.C. mains, and, as much higher voltages are likely to be involved, it is essential to see that the smoothing equipment is selected with a "safety" factor of at least 50 per cent above normal working conditions.

The smoothing or filter circuit is identical with the D.C. arrangement, excepting the inductance of the choke, which should have a higher value. For rectifiers up to the 500 volt range, it will be found that 20-25 henries with condensers of 4 mfd.-6 mfd. will be quite satisfactory.

It must be remembered that the capacity of the smoothing condensers can affect the output of the rectifier to a marked extent, therefore they must be chosen with consideration for the rectifier to be used.

Double-pole switches and fuses should be inserted in the primary side of the transformer, and the circuit should be so arranged that some visual indication is given when the circuit is alive.

High Power Rectifiers.—When H.T. voltages above 1,000 volts are required, it is now usual to use hot-cathode mercury vapour rectifiers such as the Ediswan M.U.I, and the Osram G.U.I, to quote two makes, which will supply 250 mA. at 1,000 volts.

This type of rectifier has a higher efficiency than the two-electrode thermionic valve; its internal impedance being much lower, thus increasing the efficiency and producing a practically constant voltage drop across the valve. For example, the drop across the two types mentioned above is in the neighbourhood of 15 volts.

It is essential with a mercury vapour rectifier to allow the cathode to reach its correct operating temperature before the H.T. is applied, and the makers invariably specify the use of delayed switching.

The valve depends for its operation on the ionisation of the mercury vapour contained in the bulb, a blue glow being produced during the process.

As they operate as half-way rectifiers, it is usual to use two in a bi-phase circuit to give complete rectification of the whole wave.

One point should be noticed about the filter circuit used with such arrangements, Fig. 112: it is usual, in order to provide

adequate and satisfactory regulation of the rectifier, to connect a choke filter input before the smoothing condenser, the choke having an inductance of, say, 1 to 2 henries at maximum

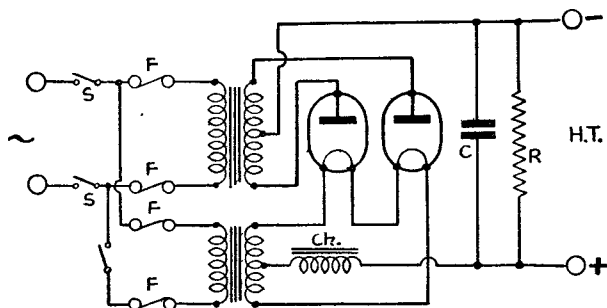

Fig. 112.—Using two half-wave rectifiers in a bi-phase circuit.

current but a very much higher value when minimum current is flowing. The resistance R limits the minimum current and serves to discharge the condenser completely when power is switched off.

CHAPTER XIV

TEN-WATT A.C. OPERATED TRANSMITTER

THE maximum power allowed by the P.M.G. when granting a full licence is 10 watts; therefore the details below will enable those who are in the position to operate such an installation to construct it or, on the other hand, use my suggestions as a basis for experimental work. To commence with, there are several limiting factors. For instance, the question of cost has to be considered; the types and number of valves; operating voltages—to avoid the necessity of costly and high voltage mains equipment—and, lastly, the type of circuit, bearing in mind modulation requirements. All the above items are, more or less, dependent on each other, the whole being governed by the length of one's pocket.

A happy medium is the following: A Crystal-controlled oscillator followed by a radio-frequency amplifier, i.e., P.A., which is modulated by a two-valve microphone amplifier, the whole receiving its operating voltages from one mains unit.

With such an arrangement, it is impossible to get a very satisfactory input to the aerial with a maximum voltage of 350 volts, so excessive cost is eliminated, while many constructors, quite possibly, have a suitable mains unit and rectifier to hand. The circuit, which will be discussed later, is such that a "frequency doubler" stage can be added in the future, if so desired, thus allowing other wavebands to be covered. The C.O. (crystal oscillator) and P.A. (power amplifier), microphone amplifier and mains power unit are made in separate sections, so one cannot do better than adopt the usual "rack" method of construction, and, in constructing this part of the installation the amateur can allow for future additions, or make it to suit any particular space.

Constructional Details.—The procedure is very similar to that of the $2\frac{1}{2}$ watt outfit, but it is suggested that angle iron and not aluminium is used, as greater rigidity is obtained, and the cost is slightly less. The main dimensions of a suitable assembly are shown in Fig. 113 where it will be seen that three floors are provided, the idea being to house the "mains" power unit in the bottom, the microphone amplifier next,

and the C.O. and P.A. in the top, an arrangement which is both ideal and compact.

The question of covering the front is a matter for individual

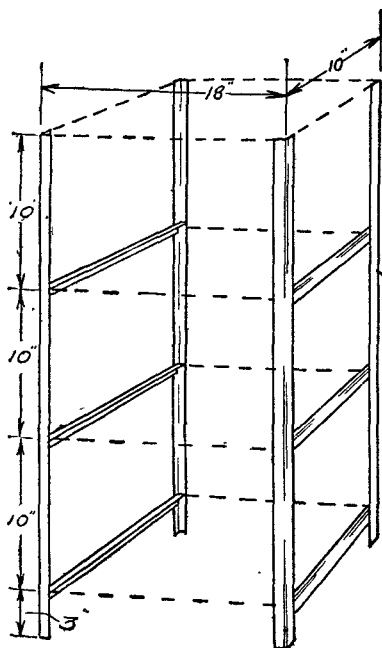

Fig. 113. — Method of building up the rack framework for the 10-watt transmitter.

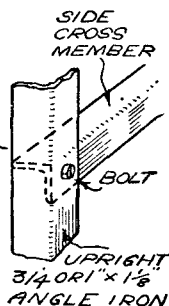
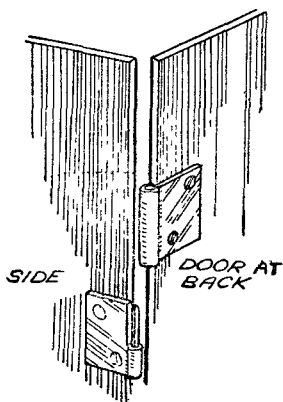

Fig. 114. — Detail showing method of fitting the back of the cabinet.



taste. Separate panels can be fixed to each baseboard, as in the case of the $2\frac{1}{2}$ watt transmitter, or the components can be mounted on brackets, as in chassis construction, and one panel used to cover the whole of the front. The latter is certainly neater but the other method allows each section to be quickly and easily withdrawn for alterations or tests.

Regarding the sides, they can be covered or left open, but beneficial screening can be obtained if they are covered with perforated zinc, which by the way, if given a hard rubbing

with metal polish will come up like silver, and add considerably to the appearance of the outfit, especially if black front panels are used. It must be remembered, that if the apparatus is so situated that children or domestic pets are likely to have access to it, the sides and back *must* be covered or protected in some way, for the safety of all concerned.

For the back, a piece of thin plywood is sufficient, and it is handy to fit the lift-off hinges which allow the whole back covering to be locked and/or lifted off and away from the job when so desired. The idea is shown in Fig. 114. If a one-piece front panel is used, it is best to fit it before fastening the cross members, the length of which must be adjusted accordingly. Similarly, the perforated zinc is also fitted into the vertical angle-pieces before the cross members are bolted down.

The Speech or Microphone Amplifier.—Fig. 115 shows the theoretical circuit. It is quite straight forward and follows normal L.F. amplifier design.

Two transformers are necessary one (T_1) for the microphone input, the ratio of which depends on the microphone requirements and T_2 a good make of output transformer having a ratio, of, say 1:1 which is connected in the anode circuit of the valve V_1 .

The volume control V.C. is essential, and it is best inserted early on in the circuit, as a more satisfactory control can be maintained. A simple switch is connected in series with the primary of T_1 and the energizing battery E.B., and in view of the fact that such batteries are often left switched on, it is advisable to provide some form of signal light, which can be operated off the same battery or off the heater circuit. A word of warning about the latter. See that you keep all A.C. leads away from microphone leads and T_1 , otherwise bad hum might be introduced.

Mention of hum brings in another very important item, namely, the screening of the amplifier against mains interference and H.F. from the transmitting section.

It is not a difficult matter to make a screening box to suit the layout of the components or, better still, well made metal boxes can be purchased for a few shillings.

It may be that a constructor already has a good one, two or three valve A.C. operated amplifier, complete with its own mains equipment. In such a case, there is no reason why it should not be used, providing, of course, that it is capable of giving distortionless amplification.

The Transmitter.—As previously decided, two valves are used in this section, and their circuits are shown in Fig. 116, V6I being a Tungstram A.P.P. 4C, and V2 an A.P.P. 4G, both being in the triple-grid output valve class, in fact, their characteristics are very similar, but the A.P.P. 4G has its control or No. 1 grid brought out to a top cap connection, thus reducing grid to anode and grid to other electrodes capacities.

It will be noticed that "suppressor grid" modulation is employed, but if so desired other methods can, of course, be tried though the beginner is well advised to stick to the above,

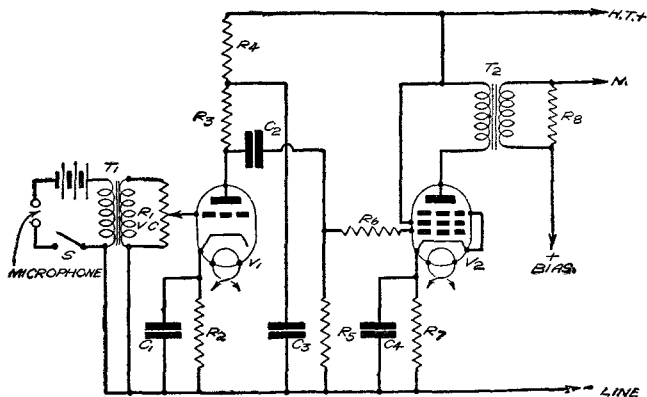

Fig. 115.—The microphone or speech amplifier circuit.

as highly satisfactory results can be obtained with the minimum of trouble.

To avoid the use of several meters, jacks are fitted in the essential leads, thus allowing one meter to serve all circuits. The meter being mounted in a convenient central position on the front panel, while the jacks should be so placed that their connecting leads are kept as short as possible.

It is advisable to note at this point, although the matter will be dealt with in detail later, that it is very important for the C.O. to be thoroughly screened from the P.A., in fact the C.O. should be assembled in one of the screening boxes previously mentioned or adequate screening built round the whole section.

For the biasing of the P.A., batteries are used, suitable H.F. chokes being included in the leads in the same manner as in

the supplies to the screens, to prevent any trace of H.F. getting into the respective circuits.

The Mains Unit.—The mains unit, for the transmitter, is shown in Fig. 117 where it will be seen that it differs slightly from normal practice, in the arrangement of the smoothing chokes.

It will be appreciated, after the diagram has been examined, that the output should be free of any trace of ripple or hum, as it is essential for the various feeds to be pure D.C., as far

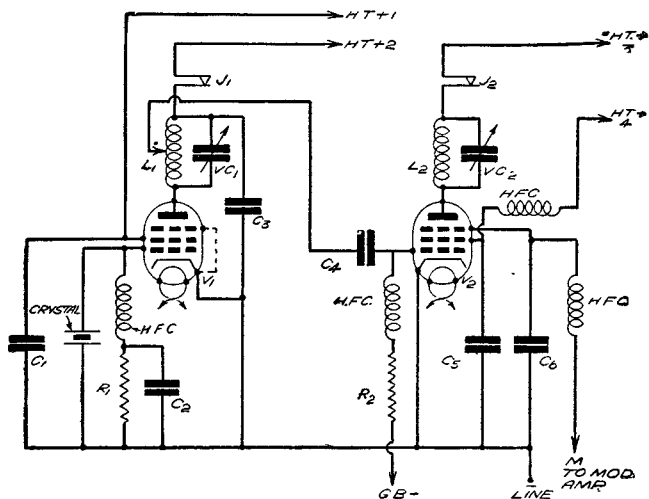

Fig. 116.—The oscillator and power amplifier circuit.

as possible, otherwise objectional snags will be introduced into the transmission.

It is not necessary for the chokes to be all of the same type or make. The vital qualifications are, sufficient inductance when carrying their current load, reasonable resistance and well constructed cores.

The various outputs are arranged for the H.T. supply points shown in the diagrams of the speech amplifier, and the C.O. and R.F. amplifier stages.

In case any constructor has a 500/0/500 volt transformer, it could be used, providing the output is reduced by shunt or series resistances to the equivalent of that indicated in Fig. 117.

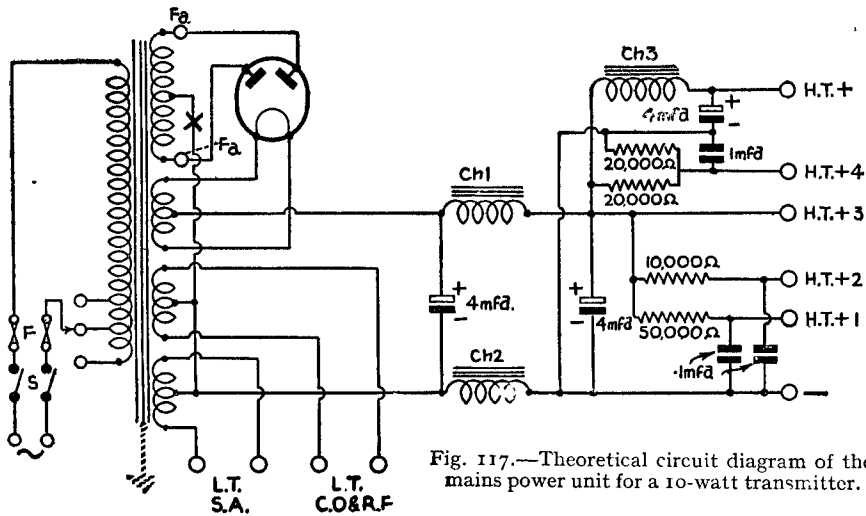

Fig. 117.—Theoretical circuit diagram of the mains power unit for a 10-watt transmitter.

The rectifier required for the unit is the Cossor 442 B.U. which has an output of 350/0/350 volts at 120 mA., the filament requiring 4 volts at 2.5 amps. As this is of the directly heated type, it is always advisable to include a reliable single pole "snap" action switch in the centre tap of the H.T. secondary winding (X on the diagram), to allow the heater to reach its maximum temperature before throwing the load into circuit, thus avoiding violent voltage surges.

The various resistances are calculated for the valves suggested, therefore, it will be necessary to modify them if other combinations are used. It is assumed that the smoothing chokes have an average resistance of, say, 500 to 600 ohms.

To avoid any misunderstanding the outputs should be connected thus. The supply from Ch.3, i.e., H.T. + is intended for the speech amplifier. H.T. + 1 is the supply for the screen of the C.O., while H.T. + 2 is for the anode circuit of the same valve. The screen of the R.F. amplifier is fed from the output H.T. + 4 and the anode from H.T. + 3, i.e., direct from the choke Ch.1.

It will be noted that a double-pole Q.M.B. switch is included in the mains supply, and fuses (F) inserted between it and the primary of the mains transformer. For the slight extra cost, it is well worth while including suitable fuses in the anodes of the rectifier, as they cost very much less than a new rectifier. The points are marked F.a.

Constructional Details.—Now as regards construction. If you are handy in working metal, a cover can be made from perforated zinc, which can be given a coat of flat black. The cover which is shown in Fig. 118, is quite easy to make, providing a little care is taken in marking and cutting it out.

The cover should, of course, be earthed, and so arranged that the main switch and fuses are outside. By the way, a pilot indication light should be provided to let you know when the circuit is alive.

There is one point to watch, and that is the position of the chokes in relation to each other. Arrange matters so that their cores are at right-angles to each other, and so that no induction can take place between them.

If all the components are mounted on a stout piece of 5-ply, the whole assembly can be fitted into the bottom of the transmitter rack, the mains supply lead being brought out at the back.

Component Values.—Referring to the diagrams Figs. 115

and 116 the following are the values for the components in the speech amplifier.

T₁, a reliable make of microphone transformer to suit the microphone in use. T₂, a good 1:1 output transformer.

Fig. 118.—The finished metal cover and (below) developed blank for making the cover for the mains unit.

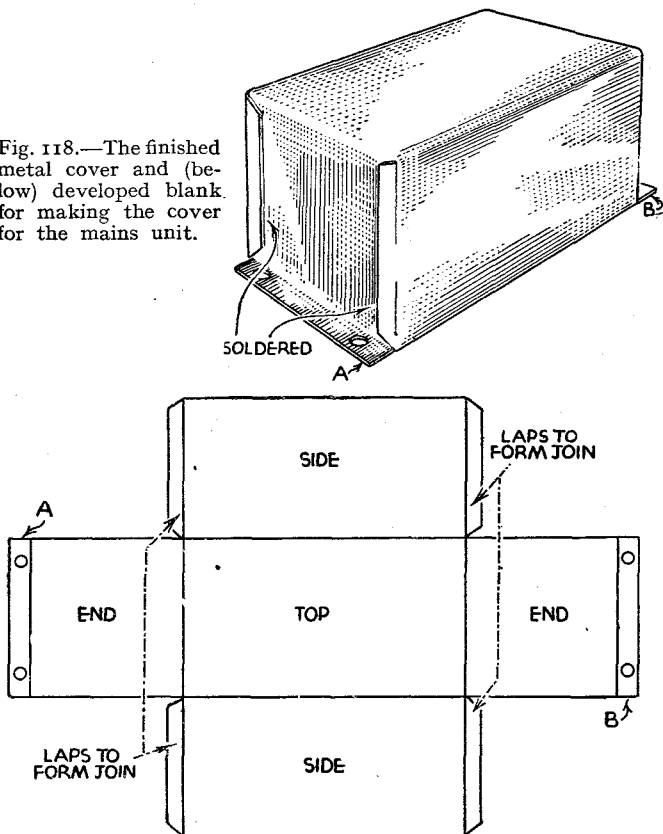

The volume control (R₁) is an Erie .5 megohm, while R₃ is 50,000 ohms; R₄, 20,000 ohms; and R₂, the bias resistance. 750 ohms for a Cossor 41 MHL, or according to valve specification.

The grid H.F. stopper, R₆ is 50,000 ohms, while the grid-leak R₅ is 0.2 megohms. The bias resistance, for a Tungram

A.P.P. 4C, is 150 ohms, its by-pass condenser C4 being 50 mfd. (12 volt rating) of the electrolytic type.

The by-pass condenser C1 (for R.2) should have the same value, for preference, though a smaller capacity can be used if one is to hand.

The intervalve coupling condenser C2 is 0.05 mfd., mica di-electric; the anode decoupling component C3 is 2 mfd. or 4 mfd., and the resistance R8 across the secondary of the output transformer T2 is 10,000 ohms.

It is advisable to use a separate battery for the energizing of the microphone, and screen all leads on the primary side of the transformer.

The C.O. Stage.—The condensers C1, C2, and C3 are 0.006 mfd., while R1 is, say, 40,000 ohms, the best value being determined, as previously explained, by experiment.

The tank circuit, L1, VC1, must be designed according to the waveband to be covered, but a value of 100 micro-microfarads for VC1 is a satisfactory capacity for the 20 to 160 metre range.

It will be remembered that it is essential for the C.O. stage to be fully screened from the remainder of the circuit, particularly the R.F. amplifier.

The R.F. Amplifier.—The coupling condenser C4 is 0.001 mfd., mica di-electric and the resistance R2 in the G.B. circuit, 10,000 ohms. The decoupling condensers C5 and C6 are 0.01 mfd. and 0.01 mfd. respectively.

There is one point to note about the tank circuit L2, VC2, and that is, it is advisable to use double-spaced vanes for VC2, and a heavy gauge copper wire coil, air spaced, for L2, it being supported by the stand-off insulators obtainable for such purposes.

All H.F. chokes must be of good make, and it is desirable to see that they do not resonate at any frequency within the band under consideration.

The actual rating of the complete transmitter, using the valves suggested, is in the neighbourhood of 7.5 watts, thus bringing it within the scope of a 10-watt licence, that being the power permissible for a beginner. It is, of course, assumed that a full licence has been obtained before the transmitter is "put on the air."

CHAPTER XV

MAKING COILS

R.F. Chokes.—Transmitting R.F. chokes, effective from 12-100 metres, can be made up by putting three sections of 75 turns each on a 1 in. diameter former, with $\frac{1}{4}$ in. between sections. Using No. 30 enamelled wire—a $\frac{1}{2}$ lb. reel of which is always handy—the total length of former required for such a choke is 4 in., and the current-carrying capacity will be 120 mA. Ribbed ebonite rod is very suitable, and can be tapped 4 BA at the ends to take terminals for finishing off and connecting up. Another good method of finishing is to tap in a valve-pin at one end, with a terminal at the other. The valve-pin can then be inserted into a valve-socket held in a small bracket on the transmitter panel. This makes changing chokes very convenient and provides a neat mounting.

Forming Windings Quickly.—A tip which may be new to some people: Windings such as those for R F. chokes, etc., can be put on very quickly by means of an ordinary breast-drill. The former is held in the chuck and the drill fixed horizontally in the vice. Unless the former is of small enough diameter itself to enter the chuck, a reducing device is necessary. This can be a screw fixed such that it is central with the axis of the former, $\frac{1}{2}$ in. or so being left projecting to go in the chuck.

Counting turns is simplicity itself. Find how many times the chuck revolves for one revolution of the drill handle, and divide this figure into the number of turns to be put on. This last figure gives the number of handle revolutions required which can be easily counted as it is turned. One hand is used for working the drill and the other for running on the wire, the bobbin being mounted in some convenient fashion allowing it to turn easily.

For those who like to produce as much as possible of their gear for themselves, here is a method of making transmitting inductances; not the copper tube type, which are simple enough, but the other kind where 12 or 14 S.W.G. bare copper wire is used.

Decide on the diameter required in the finished coil, say about $3\frac{1}{2}$ in., and on a former $\frac{1}{2}$ in. smaller (3 in. in this case),

wind on tightly thick string or blind cord, so that the turns of cord lie closely together. The length of this winding along the former should be just a little more than the finished length of the inductance. Then, over the string, lay a few sheets of grease-proofed or waxed paper, fixed in position with strips of sticky paper. We now have a thickened tube on which to form the coil, the thickening being easily removable by pulling off the cord. The next step is to lay celluloid strips parallel to the length of the former, four strips being used an equal distance apart—at 90 degrees when looking at the ends of the former. These strips must be fastened temporarily by screws or tacks to keep them in position.

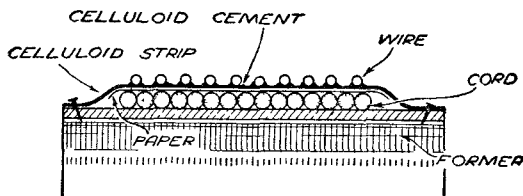

Fig. 119.—Showing the method of building up the former.

Method of Winding.—After this, the wire can be wound on. The best way to do it is to calculate approximately the length required (multiply the diameter of the coil in inches by number of turns by 3.2, and divide the result by 12, giving the answer in feet of wire), and then get somewhere so that this length can be stretched out. Then, fixing one end of the wire to a hook, pull it tight to get the kinks out. Running the handle of a screw-driver, or something similar, along it will not only help in doing this, but the wire can be polished at the same time.

Having thus stretched out the necessary length of wire, one end of which is fastened, the other end should be temporarily fixed to the former, and the winding can be commenced. Hold the former in both hands, and turn it towards you, keeping the wire tight as you walk towards the end fixed to the wall. Spacing of the turns can be judged by eye, since by turning the former anti-clockwise, as mentioned above, the winding is in view all the time.

Another method of spacing the turns is to interleave the wire with thick cord, but in the writer's experience this is not

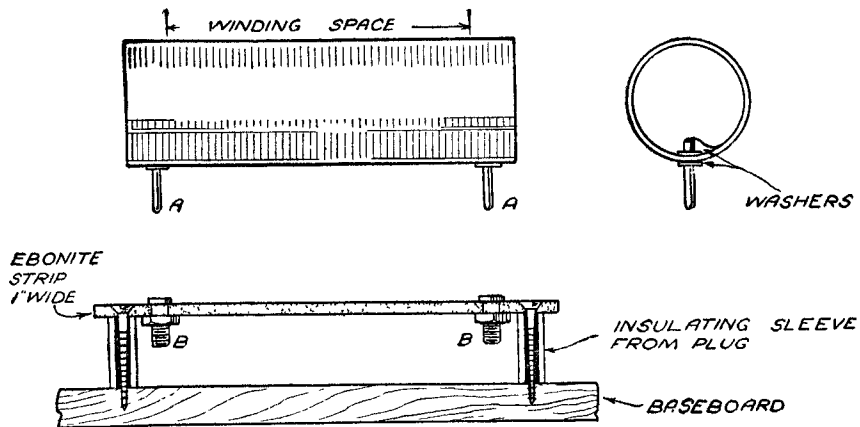

Fig. 120.—Showing a convenient method of mounting low-power coils. A-A are plugs with the insulating sleeving removed, B-B are correspond ing sockets. The sleeves from the plugs are used as spacers for holding the mounting strip away from the baseboard.

only very awkward if the turns are to be kept tight, but introduces a practical difficulty in that the spacing usually required for a transmitting inductance necessitates very thick cord.

When the required number of turns have been put on, the second end should be secured by looping it back and tying it down to the former with string. Remember to leave enough for the mounting connections. We now have a former built up to a "false diameter" by means of the cord windings overlaid with paper, super-imposed on which are the celluloid strips, over them again being the wire for the coil itself. Fig. 119 is a half-section showing this.

Fixing the Celluloid Strips.—The next step is to fix the wire to the celluloid strips. This is done by making a thick paste of celluloid scrapings rendered down with amyl acetate, obtainable at any chemist's. When buying the amyl acetate, have a proportion of acetone added. This will cost about 6d. altogether for a 2 oz. bottle.

Apply the paste with a small brush, paying particular attention to the end turns, and applying it liberally along the whole length of each of the four strips, so that the wire will be locked in position when the cement is dry. Drying takes about 24 hours, and the coil will not be ready for taking off the former till the cement is absolutely hard.

To get the coil off, unfasten the ends of the celluloid strip from the former and then pull off the string from under the paper. This leaves the coil, with the paper sticking to the celluloid in places, free to come off. Tear out the paper, cutting it away with a sharp knife where necessary, and you have your coil, the turns of which are evenly spaced and solidly fixed to the celluloid strips. The final process is to trim off the ends of the strips, close to the end turns, form the mounting loops for attaching the coil to its stand-off insulators, and, if you like, go over the coil with a clear lacquer. Your coil will be a sound job from the R.F. point of view, with the number of turns, spacing, etc., just as you require.

Here are some further points :

(1) 12 or 14 S.W.G. bare copper wire can usually be obtained at ironmongers by the pound weight. No. 12 runs about 30 ft. to the pound.

(2) Form your turns to leave enough room for crocodile clips, i.e., so that turns will not be shorted. This means spacing about $\frac{1}{4}$ in. or so.

(3) Celluloid for making the strips, which should be $\frac{3}{8}$ in. wide, can often be obtained from a garage; old side-curtains are quite good enough.

(4) A substitute for the amyl acetate-celluloid paste is "Durofix," obtainable at ironmongers. A 6d. tube will do one average-size coil.

(5) It is always best to make up coils having an even number of turns. Then, the centre-tap connection comes underneath, midway between the mounting ends.

(6) Coils of No. 12 wire should be used; low capacity to keep the circulating current down. If the coil warms up, losses ensue. To explain this: A 14-turn *copper-tube* coil in the P.A. stage with 300 mmfd. in parallel for 80 m., will warm up with 10-15 watts input, due to the high circulating current. Using a 30-turn coil of No. 12 of the type described, with about 50 mfd. in parallel for the same band, the coil will remain quite cold with 100 watts input, as the circulating current will be very low. The driven P.A. stage should always have a low capacity tank circuit.

(7) Don't leave off the grease-proofed paper mentioned—you can get enough to last a lifetime for 3d.—because it prevents the celluloid paste sticking to the cord, and keeps the paste where it is wanted. Some paste will stick to the paper, but it is easier to get the paper off than strands of string.

(8) Don't expect your first effort to make one of these coils to be a huge success. There is a knack in the whole job, but after a little practice coils can be run up in half-an-hour or so.

Mounting Low-power Inductances.—Coils for the crystal oscillator or buffer frequency-doubler stages can be close-wound on a 2 in. diameter former, using No. 18 enamelled. If plug-in-formers are not available, it is sometimes a problem how to mount such coils. One good way is to make use of banana-plugs and sockets. The latter are fixed the required distance apart on an ebonite strip, and the plugs have the insulating portion removed. Then drill holes at the ends of the coil former so that the stripped plugs are a tight fit. Slip $\frac{3}{16}$ in. brass washers over the plugs on each side, soldering them in position. The ends of the coil are then soldered to the plugs which, while they are tight electrically, have sufficient play to centre with the sockets.

Fig. 120 shows the idea, also how to use the discarded insulating sleeves of the plugs to act as spacers supporting the mounting strip.

INTERNATIONAL MORSE CODE

A	dit dah	..-
B	dah dit dit dit	---..
C	dah dit dah dit	---..
D	dah dit dit	---.
E	dit	.
F	dit dit dah dit	..---
G	dah dah dit	---.
H	dit dit dit dit
I	dit dit	..
J	dit dah dah dah	..--
K	dah dit dah	---
L	dit dah dit dit	..---
M	dah dah	---
N	dah dit	---.
O	dah dah dah	---
P	dit dah dah dit	---..
Q	dah dah dit dah	---..
R	dit dah dit	---.
S	dit dit dit	...
T	dah	-
U	dit dit dah	..-
V	dit dit dit dah	...-
W	dit dah dah	..--
X	dah dit dit dah	---..
Y	dah dit dah dah	---..
Z	dah dah dit dit	---..

Number Code.

1	dit dah dah dah dah	-----
2	dit dit dah dah dah	-----
3	dit dit dit dah dah	-----
4	dit dit dit dit dah	-----
5	dit dit dit dit dit
6	dah dit dit dit dit	-----
7	dah dah dit dit dit	-----
8	dah dah dah dit dit	-----
9	dah dah dah dah dit	-----
0	dah dah dah dah dah	-----

Note of interrogation	dit dit dah dah dit dit
Note of exclamation	dah dah dit dit dah dah	-----
Apostrophe	dit dah dah dah dah dit	-----
Hyphen	dah dit dit dit dit dah	-----
Fractional bar	dah dit dit dah dit	-----
Brackets	dah dit dah dah dit dah	-----
Inverted commas	dit dah dit dit dah dit	-----
Underline	dit dit dah dah dit dah	-----
Preliminary call	dah dit dah dit dah	-----
Break sign	dah dit dit dit dah	-----
End of message	dit dah dit dah dit	-----
Error	dit dit dit dit dit dit dit
	(series of dots)	

INTERNATIONAL "Q" CODE

Abbreviation	Question	Answer for Advice
QRA	What is the name of your station?	The name of my station is ...
QRB	How far approximately are you from my station? ..	The approximate distance is miles.
QRD	Where are you bound and where are you from? ..	I am bound for . . . from . . .
QRG	Will you tell me my exact frequency in kilocycles? ..	Your exact frequency is . . . kc
QRH	Does my frequency vary? ..	Your frequency varies.
QRI	Is my note good?	Your note varies.
QRJ	Do you receive me badly? ..	I cannot receive you.
	Are my signals weak? ..	Your signals are too weak.
QRK	Do you receive me well? ..	I receive you well.
	Are my signals good? ..	Your signals are good.
QRL	Are you busy?	I am busy. Please do not interfere.
QRM	Are you being interfered with?	I am being interfered with.
QRN	Are you troubled by atmospherics?	I am troubled by atmospherics.
QRO	Shall I increase power? ..	Increase power.
QRP	Shall I decrease power? ..	Decrease power.
QRQ	Shall I send faster?	Send faster (. . . words per minute).
QRS	Shall I send more slowly? ..	Send more slowly (. . . words per minute).
QRT	Shall I stop sending? ..	Stop sending.
QRU	Have you anything for me? ..	I have nothing for you.
QRV	Are you ready?	I am ready.
QRX	Shall I wait? When will you call me again? *	Wait (or wait until I have finished communicating with . . .) I will call you at . . . GMT.
QRZ	Who is calling me? ..	You are being called by
QSA	What is the strength of my signals? (1 to 5) ..	The strength of your signals is . . . (1 to 5)
QSB	Does the strength of my signals vary?	The strength of your signals varies.
QSD	Is my keying correct? Are my signals distinct? ..	Your keying is indistinct; Your signals are bad.
QSL	Can you give me acknowledgment of receipt? ..	I give you acknowledgment of receipt.
QSM	Shall I repeat the last telegram (message) I sent you?	Repeat the last telegram (message) you have sent me.
QSO	Can you communicate with . . . direct (or through the medium of)?	I can communicate with . . . direct (or through the medium of . . .).
QSP	Will you retransmit to . . . ?	I will retransmit to . . .
QSV	Shall I send a series of V's?	Send a series of V's.

INTERNATIONAL "Q" CODE—continued

Abbreviation	Question	Answer for Advice
QSX	Will you listen for . . . (call sign) on . . . kc ?	I am listening for . . . (call sign) on . . . kc.
QSZ	Shall I send each word or group twice ?	Send each word or group twice.
QTH	What is your position in latitude and longitude ?	My position is . . . latitude . . . longitude.
QTR	What is the exact time ?	The exact time is . . .

MISCELLANEOUS INTERNATIONAL ABBREVIATIONS

Abbrev.	Meaning	Abbrev.	Meaning
C	.. Yes	GA	.. Resume sending
N	.. No	MN	.. Minute/minutes
W	.. Word	NW	.. I resume transmission
AA	.. All after . . .	OK	.. Agreed
AB	.. All before . . .	UA	.. Are we agreed ?
AL	.. All that has just been sent	WA	.. Word after . . .
BN	.. All between	WB	.. Word before . . .
CL	.. I am closing my station	XS	.. Atmospheric

AMATEUR ABBREVIATIONS

Abbrev.	Meaning	Abbrev.	Meaning
ABT	.. About	FM	.. From
AGN	.. Again	GA	.. Go ahead, or Good afternoon
ANI	.. Any	GB	.. Good-bye
BA	.. Buffer amplifier	GE	.. Good evening
BCL	.. Broadcast listener	GM	.. Good morning
BD	.. Bad	GN	.. Good night
BI	.. By	HAM	.. Radio amateur
BK	.. Break in	HI	.. Laughter
BN	.. Been	HR	.. Hear, or here
CK	.. Check	HRD	.. Heard
CKT	.. Circuit	HV	.. Have
CLD	.. Called	LTR	.. Later
CO	.. Crystal oscillator	MILS	.. Milliampere
CUD	.. Could	MO	.. Meter Oscillator
CUL	.. See you later	ND	.. Nothing doing
DX	.. Long distance	NIL	.. Nothing
ECO	.. Electron-coupled oscillator	NM	.. No more
ES	.. And	NR	.. Number
FB	.. Fine business (good work)	NW	.. Now
FD	.. Frequency doubler	OB	.. Old boy
		OM	.. Old man

AMATEUR ABBREVIATIONS—continued

Abbrev.	Meaning	Abbrev.	Meaning
OT	.. Old timer	TNX	.. Thanks
PA	.. Power amplifier	TPTG	.. Tuned plate tuned grid
PSE	.. Please	TX	.. Transmitter
R	.. Received all sent	U	.. You
RAC	.. Rectified A.C.	UR	.. You are
RCD	.. Received	VY	.. Very
RX	.. Receiver	WDS	.. Words
SA	.. Say	WKG	.. Working
SED	.. Said	WL	.. Will
SIGS	.. Signals	WUD	.. Would
SIGN	.. Signature	WX	.. Weather
SSS	.. Single Signal super-heterodyne receiver.	YF	.. Wife
SKD	.. Schedule.	YL	.. Young Lady
TKS	.. Thanks.	YR	.. Your
TMN	.. To-morrow	73	.. Kind regards
		88	.. Love and kisses

QSA CODE (Signal Strength)

QSA1	.. Hardly perceptible ; unreadable
QSA2	.. Weak, readable now and then
QSA3	.. Fairly good ; readable, but with difficulty
QSA4	.. Good ; readable
QSA5	.. Very good ; perfectly readable

QRK CODE (Audibility)

R1	.. Faint signals ; just readable
R2	.. Weak signals ; barely readable.
R3	.. Weak signals ; but can be copied
R4	.. Fair signals ; easily readable
R5	.. Moderately strong signals
R6	.. Good signals
R7	.. Good strong signals
R8	.. Very strong signals
R9	.. Extremely strong signals

RST CODE**Readability**

1	.. Unreadable
2	.. Barely readable, occasional words distinguishable
3	.. Readable with considerable difficulty
4	.. Readable with practically no difficulty
5	.. Perfectly readable

R S T CODE—continued

Signal Strength

- 1 .. Faint, signals barely perceptible
- 2 .. Very weak signals
- 3 .. Weak signals
- 4 .. Fair signals
- 5 .. Fairly good signals
- 6 .. Good signals
- 7 .. Moderately strong signals
- 8 .. Strong signals
- 9 .. Extremely strong signals

Tone

- 1 .. Extremely rough hissing note
- 2 .. Very rough A.C. note, no trace of musicality
- 3 .. Rough, low-pitched A.C. note, slightly musical
- 4 .. Rather rough A.C. note, moderately musical
- 5 .. Musically modulated note
- 6 .. Modulated note, slight trace of whistle
- 7 .. Near D.C. note, smooth ripple
- 8 .. Good D.C. note, just a trace of ripple.
- 9 .. Purest D.C. note

(If the note appears to be crystal-controlled add an X after the appropriate number).

PHONETIC ALPHABET

To avoid the possibility of the letters of the call sign being misunderstood, it is usual to use the words given below in place of the letters. For example, G6XY would be given as G6 Xanthippe Yokohama.

Letters to be spelt	Words to be used for spelling	Letters to be spelt	Words to be used for spelling
A	Amsterdam	N	New York
B	Baltimore	O	Oslo
C	Casablanca	P	Paris
D	Denmark	Q	Quebec
E	Edison	R	Roma
F	Florida	S	Santiago
G	Gallipoli	T	Tripoli
H	Havana	U	Upsala
I	Italy	V	Valencia
J	Jerusalem	W	Washington
K	Kilogram	X	Xanthippe
L	Liverpool	Y	Yokohama
M	Madagascar	Z	Zurich

INTERNATIONAL CALL SIGNS

AC ₄	Tibet	FY	Guyane (French Guana)
AR	Syria	G	British Isles (G—England; GM—Scotland; GW—Wales)
CE	Chile	GI	North Ireland
CM	Cuba	HA	Hungary
CN ₁	Tangier Zone	HB	Switzerland
CNB	Morocco	HC	Ecuador
CO	Cuba (fone)	HH	Haiti
CP	Bolivia	H1	Dominican Republic
CR ₄	Cape Verde Islands	HJ	Colombia
CR ₅	Portuguese Guinea	HK	Colombia
CR ₆	Angola	HP	Republic of Panama
CR ₇	Mozambique	HR	Honduras
CR ₈	Portuguese India	HS	Siam
CR ₉	Macao	HZ	Hedjaz
CR ₁₀	Timor	I	Italy
CT ₁	Portugal	J	Japan
CT ₂	Azores	J ₈	Chosen (Korea)
CT ₃	Madeira Island	J ₉	Formosa
CX	Uruguay	K ₄	Virgin Islands
D	Germany	K ₅	Canal Zone
EA	Spain	K ₆	Hawaii
EA ₆	Balearic Islands	K ₆	Guam
EA ₈	Canary Islands	K ₆	Samoa
EA ₉	Spanish Morocco	K ₆	Midway and Wake Islands
EI	Irish Free State	K ₇	Alaska
EL	Liberia	KA	Philippines
EP	Iran (Persia)	LA	Norway
EQ	Iran (Persia)	LU	Argentina
ES	Estonia	LX	Luxembourg
ET	Ethiopia (Abyssinia)	LY	Lithuania
F	France	LZ	Bulgaria
FA	Algeria	MX	Manchukuo
FB	Madagascar	NY	Canal Zone
FD	French Togoland	OA	Peru
FE	French Camerouns	OE	Austria
FF	French West Africa	OH	Finland
FG	Guadeloupe	OK	Czechoslovakia
FI	French Indo-China	OM	Guam
FK	New Caledonia	ON	Belgium
FL	French Somaliland	OQ ₅	Belgian Congo
FM	Martinique	OX	Greenland
FN	French India	OY	Faroe Islands
FO	French Oceania	OZ	Denmark
FP	St. Pierre and Miquelon	PA	Netherlands
FQ	French Equatorial Africa	PJ	Curaçao
FR	Reunion Island		
FT	Tunisia		
FU	French New Hebrides		

PK1, 2, 3	Java	VP6	Barbados
PK4	Sumatra	VP7	Bahamas
PK5	Dutch Borneo	VP8	Falkland Is., South Georgia
PK6	Celebes-New Guinea	VP9	Bermuda
PX	Andorra	VQ1	Fanning Island
PY	Brazil	VQ2	Northern Rhodesia
PZ	Surinam (Dutch Guiana)	VQ3	Tanganyika
SM	Sweden	VQ4	Kenya
SP	Poland	VQ5	Uganda
ST	Anglo-Egyptian Sudan	VQ6	British Somaliland
SU	Egypt	VQ8	Mauritius
SV	Greece	VQ9	Chagos Archipelago
SX	Greece	VR1	Seychelles
TA	Turkey		Gilbert and Ellice Islands
TF	Iceland	VR2	Fiji Islands
TG	Guatemala	VR4	Solomon Islands
TI	Costa Rica	VR5	Tonga Islands
UI, 3, 4, 7	European Russian S.F.S.R.	VR6	Pitcairn Island
U2	White Russian S.S.R.	VS1	Straits Settlements
U5	Ukranian S.S.R.	VS2	Federated Malay States
U6	Transcaucasian S.F.S.R.	VS3	Non-Federated Malay States
U8	Uzbek S.S.R. and Tur- koman S.S.R.	VS4	North Borneo
U9, 0	Asiatic Russian S.F.S.R.	VS5	Sarawak
(Note—Prefix letters UX, UE, UK also used occasionally).		VS6	Hong Kong
VE1	Canada	VS7	Ceylon
VE2	Canada	VS8	Bahrein Islands
VE3	Canada	VS9	Maldiv Islands
VE4	Canada	VU	India
VE5	Canada	W1	U.S.A.
VE5	North-West Territories	W2	U.S.A.
VK2	Australia	W3	U.S.A.
VK3	Australia	W4	U.S.A.
VK4	Australia	W5	U.S.A.
VK5	Australia	W6	U.S.A.
VK6	Australia	W7	U.S.A.
VK7	Tasmania	W8	U.S.A.
VK8	Australia	W9	U.S.A.
VK9	New Guinea	XE	Mexico
VO	Newfoundland, Labrador	XU	China
VP1	British Honduras	XZ	Burma
VP2	Windward Islands	YA	Afghanistan
VP2	Leeward Islands	YI	Iraq
VP3	British Guiana	YJ	New Hebrides
VP4	Trinidad, Tobago	YL	Latvia
VP5	Jamaica, Caicos, Cay- man Islands, Turks Islands.	YM	Danzig
		YN	Nicaragua
		YR	Roumania
		YS	Salvador
		YT	Jugoslavia
		YU	Jugoslavia
		YV	Venezuela

ZA	Albania	ZD6	Nyasaland
ZB ₁	Malta	ZD7	St. Helena
ZB ₂	Gibraltar	ZD8	Ascension Island
ZC ₁	Transjordan	ZE	Southern Rhodesia
ZC ₂	British Cocos Islands	ZK ₁	Cook Islands
ZC ₃	Christmas Island	ZK ₂	Niue
ZC ₄	Cyprus	ZL	New Zealand
ZC ₅	Palestine	ZM	British Samoa
ZD ₁	Sierra Leone	ZP	Paraguay
ZD ₂	Nigeria, British Cameroons	ZS	Union of South Africa
ZD ₃	Gambia	ZT	Union of South Africa
ZD ₄	Gold Coast, British Togoland	ZU	Union of South Africa
		ZU ₉	Tristan da Cunha

WAVELENGTH-FREQUENCY CONVERSION TABLE

Metres to Kilocycles and Megacycles

Metres	Kilocycles	Megacycles	Metres	Kilocycles
5	60,000	60	360	833.3
10	30,000	30	370	810.8
20	15,000	15	380	789.5
30	10,000	10	390	769.2
40	7,500	7.5	400	750
50	6,000	6	410	731.7
60	5,000	5	420	714.3
70	4,285	4.28	430	697.7
80	3,750	3.7	440	681.8
90	3,333	3.3	450	666.7
100	3,000	3.0	460	652.2
150	2,000	2.0	470	638.3
200	1,500	1.5	480	625
205	1,463	1.46	490	612.2
210	1,429	1.42	500	600
215	1,395	1.39	510	588.2
220	1,364	1.36	520	576.9
225	1,333	1.33	530	566
230	1,304	1.3	540	555.6
235	1,277	1.27	550	545.4
240	1,250	1.25	560	535.7
245	1,225	1.22	570	526.3
250	1,200	1.2	580	517.2
255	1,177	1.17	590	508.5
260	1,154	1.15	600	500
265	1,132	1.13	650	461.5
270	1,111	1.11	700	428.6
275	1,091	1.09	750	400
280	1,071	1.07	800	375
290	1,034	1.03	850	352.9
295	1,017	1.017	900	333.3
300	1,000	1.0	950	315.9
310	967.7		1,000	300
320	937.5		1,250	240
330	909.1		1,500	200
340	882.4		1,750	171.4
350	857.1		2,000	150

Note.—To convert kilocycles to wavelength in metres, divide 300,000 by the number of kilocycles.

To convert wavelength in metres to kilocycles, divide 300,000 by the number of metres.

To convert kilocycles to megacycles, divide by 1000.

SYMBOLS

Amplification factor	m, μ . (Mu)
Ampere	A
Anode A.C. Resistance (Impedance)	R_a, R_o
Anode Current	I_a
Anode Potential	V_a
Anode Circuit Inductance	L_a
Current (R.M.S. Value)	I
Current (Instantaneous)	i
Capacity	C
Dielectric constant	ϵ
Energy	W
E.M.F. (Voltage) R.M.S. Value	E
E.M.F. (Instantaneous)	e
Frequency	f
Farad	F
Grid-Anode Capacity	C_{ga}
Grid Circuit Inductance	L_g
Grid Current	I_g
Grid Potential	V_g
Henry	H
Impedance	Z
Inductance	L
Length	l
Mass	m
Mutual Inductance	M
Magnetic Flux (Reluctance)	Φ (or S)
Magnetic Flux Density	B
Magnetic Field	H
Ohm	Ω
Power	P
Power Output	P_o
Phase Angle	ϕ
Quantity of Electricity	Q
Resistance	R
Resistivity (Specific resistance)	ρ
Resistance at Resonance	R
Reactance	X
Permeability	μ
Self Inductance	L
Susceptibility	π
Time	t
Velocity	v
Volt	V
Watt	W
Wavelength	λ
$2 \pi f$	ω

"Practical Wireless" BLUEPRINT SERVICE

These Blueprints are drawn full size.

Copies of appropriate issues containing descriptions of these sets can in some cases be supplied at the following prices, which are additional to the cost of the Blueprint. A dash before the Blueprint Number indicates that the issue is out of print

PRACTICAL WIRELESS issues dated prior to June 1st, 1940, 4d. post paid; issues dated June 1st to July 27th, 1940, 5d. post paid; issues dated September, 1940 and after, 7d. post paid,

AMATEUR WIRELESS --- --- 4d. **POST PAID**
WIRELESS MAGAZINE --- --- 1/4 " "

The index letters which precede the Blueprint Number indicate the periodical in which the description appears: Thus P.W. refers to *Practical Wireless*, A.W. to *Amateur Wireless*, W.M. to *Wireless Magazine*.

Send (preferably a postal order to cover the cost of the blueprint and the issue (stamps over 6d. unacceptable) to PRACTICAL WIRELESS SERVICE MANUAL Blueprint Dept., George Newnes, Ltd., Tower House, Southampton Street, Strand W.C.2.

Date of Issue.		No. of Blueprint	Date of Issue.		No of Blueprint
CRYSTAL SETS.					
Blueprints, 6d. each.					
1937 Crystal Receiver	---	PW71			
The "Junior" Crystal Set	27.8.38	PW94			
STRAIGHT SETS. Battery Operated.					
One-Valve: Blueprints, 1s. each.					
All-wave Unipen (Pentode)	---	PW31A			
Beginner's One-valver	19.2.38	PW85			
The "Pyramid" One-valver (HF Pen)	27.8.38	PW93			
Two-valve: Blueprints, 1s. each.					
The Signet Two (D & LF)	24.9.38	PW76			
Three-valve: Blueprints, 1s. each.					
Selectone Battery Three (D, 2 LF (Trans))	---	PW10			
Sixty Shalling Three (D, 2 LF (RC & Trans))	---	PW4A			
Leader Three (SG, D, Pow)	---	PW85			
Summit Three (HF Pen, D, Pen)	---	PW37			
All Pentode Three (HF Pen, D (Pen), Pen)	---	PW39			
Hall-mark Three (SG, D, Pow)	---	PW41			
Hall-mark Cadet (D, LF, Pen (RC))	---	PW48			
F. J. Camm's Silver Souvenir (HF Pen, D (Pen), Pen) (All-wave Three)	---	PW49			
Cameo Midget Three (D, 2 LF (Trans.))	---	PW51			
1936 Sonotone Three-Four (HF Pen, HF Pen, Westector, Pen)	---	PW53			
Battery All-Wave Three (D, 2 LF (RC))	---	PW55			
The Monitor (HF Pen, D, Pen)	---	PW61			
The Tutor Three (HF Pen, D, Pen)	---	PW62			
The Centaur Three (SG, D, P)	---	PW64			
F. J. Camm's Record All-Wave Three (HF Pen, D, Pen)	---	PW69			
The "Colt" All-Wave Three (D, 2 LF (RC & Trans))	18. --	PW72			
The "Rapid" Straight 3 (D, 2 LF (RC & Trans))	---	PW82			
F. J. Camm's Oracle All-Wave Three (HF, Det, Pen)	---	PW78			
1938 "Triband" All-Wave Three (HF Pen, D, Pen)	---	PW84			
F. J. Camm's "Sprite" Three (HF Pen, D, Tet)	26.3.38	PW87			
The "Hurricane" All-Wave Three (SG, D (Pen), Pen)	---	PW89			
F. J. Camm's "Push-Button" Three (HF Pen, D (Pen), Tet)	3.9.38	PW92			
Four-valve: Blueprints, 1s. each.					
Fury Four (2 SG, D, Pen)	---	PW11			
Mains Operated.					
Two-valve: Blueprints, 1s. each.					
A.C. Twin (D (Pen), Pen)	---				PW18
A.C.-D.C. Two (SG, Pow)	---				PW31
Selectone, A.C. Radiogram Two (D, Pow)	---				PW19
Three-valve: Blueprints, 1s. each.					
Double-Diode-Triode Three (HF Pen, DDT, Pen)	---				PW23
D.C. Ace (SG, D, Pen)	---				PW25
A.C. Three (SG, D, Pen)	---				PW29
A.C. Leader (HF Pen, D, Pow)	7.1.39				PW35C
D.C. Premier (HF Pen, D, Pen)	---				PW35B
Ubique (HF Pen, D (Pen), Pen)	---				PW36A
Armada Mains Three (HF Pen, D, Pen)	---				PW38
F. J. Camm's A.C. All-Wave Silver Souvenir Three (HF Pen, D, Pen)	---				PW50
"All-Wave" A.C. Three (D, 2 LF (RC))	---				PW54
A.C. 1936 Sonotone (HF Pen, HF Pen, Westector, Pen)	---				PW56
Mains Record All-Wave 3 (HF Pen, D, Pen)	---				PW70
Four-valve: Blueprints, 1s. each.					
A.C. Fury Four (SG, SG, D, Pen)	---				PW20
A.C. Fury Four Super (SG, SG, D, Pen)	---				PW34D
A.C. Hall-Mark (HF Pen, D, Push-Pull)	---				PW45
Universal Hall-Mark (HF Pen, D, Push-Pull)	---				PW47
SUPERHETS.					
Battery Sets: Blueprints, 1s. each.					
35 Superhet (Three-valve)	---				PW40
F. J. Camm's 2-valve Superhet	---				PW32
Mains Sets: Blueprints, 1s. each.					
A.C. 45 Superhet (Three-valve)	---				PW43
D.C. 45 Superhet (Three-valve)	---				PW42
Universal 45 Superhet (Three-valve)	---				PW44
F. J. Camm's A.C. Superhet 4	---				PW59
F. J. Camm's Universal 44 Superhet 4	---				PW60
"Qualitone" Universal Four	---				PW73

	Date of Issue.	No. of Blueprint
Four-valve: Double-sided Blueprint, 1s. 6d.		
Push-Button 4, Battery Model	22.10.38	PW95
Push-Button 4, A.C. Mains Model		

SHORT-WAVE SETS. Battery Operated.		
One-valve: Blueprint, 1s.		
Simple S.W. One-valver	23.12.39	PW88
Two-valve: Blueprints, 1s. each.		
Midget Short-wave Two (D, Pen)		PW38A
The "Fleet" Short-wave Two (D (HF Pen), Pen)	27.8.38	PW91
Three-valve: Blueprints, 1s. each.		
Experimenter's Short-wave Three (SG, D, Pow)		PW30A
The Pretect 3 (D, 2 LF (RC and Trans))		PW63
The Band-Spread S.W. Three (HF Pen, D (Pen), Pen)		PW68

PORTABLES.		
Three-valve: Blueprints, 1s. each.		
F. J. Camm's ELF Three-valve Portable (HF Pen, D, Pen)		PW65
Parvo Flyweight Midget Portable (SG, D, Pen)	3.6.39	PW77
Four-valve: Blueprint, 1s.		
"Imp" Portable 4 (D, LF, LF, Pen)		PW86

MISCELLANEOUS.		
Blueprint 1s.		
S.W. Converter-Adapter (1 valve)		PW48A

AMATEUR WIRELESS AND WIRELESS MAGAZINE CRYSTAL SETS.

Blueprints, 6d.		
Four-station Crystal Set	23.7.38	AW427
1934 Crystal Set		AW444
150-mile Crystal Set		AW450

STRAIGHT SETS. Battery Operated.		
One-valve: Blueprints, 1s.		
B.B.C. Special One-Valver		AW387
Two-valve: Blueprints, 1s. each.		
Melody Ranger Two (D, Trans)		AW388
Full-volume Two (SG det, Pen)		AW392
Lucerne Minor (D, Pen)		AW426
A Modern Two-valver		WM409
Three-valve: Blueprints, 1s. each.		
45 5s. S.G.3 (SG, D, Trans)		AW412
Lucerne Ranger (SG, D, Trans)		AW422
45 5s. Three: De Luxe Version (SG, D, Trans)	19.5.34	AW435
Lucerne Straight Three (D, RC, Trans)		AW437
Transportable Three (SG, D, Pen)		WM271
Simple-Tune Three (SG, D, Pen)		WM327
Economy-Pentode Three (SG, D, (Pen) "W.M." 1934 Standard Three (SG, D, Pen)		WM337
43 3s. Three (SG, D, Trans)		WM351
1935 40 6s. Battery Three (SG, D, Pen)		WM354
PTF Three (Pen, D, Pen)		WM371
Certainty Three (SG, D, Pen)		WM389
Manitube Three (SG, D, Trans)	Oct '35	WM393
All-Wave Winning Three (SG, D, (Pen))		WM400
Four-valve: Blueprints, 1s. 6d. each.		
65a. Four (SG, D, RC, Trans)		AW370
2HF Four (2 SG, D, Pen)		AW421
Self-contained Four (SG, D, LF, Class B)	Aug. '33	WM341
Lucerne Straight Four (SG, D, LF, Trans)		WM350
45 5s. Battery Four (HF, D, 2 LF)	Feb. '35	WM381
The H.K. Four (SG, SG, D, Pen)		WM384
The Auto Straight Four (HF Pen, HF Pen, DDT, Pen)	Apr. '36	WM404
Five-valve: Blueprints, 1s. 6d. each.		
Super-quality Five (2 HF, D, RC, Trans)		WM320
Class B Quadradyne (2 SG, D, LF, Class B)		WM344
New Class B Five (2 SG, D, LF, Class, B)		WM340

Mains Operated.		
Two-valve: Blueprints, 1s. each.		
Consoelectric Two (D, Pen) A.C.		AW403
Economy A.C. Two (D, Trans) A.C.		WM286
Unicorn A.C.-D.C. Two (D, Pen)		WM394

Three-valve: Blueprints, 1s. each.		
Home Lover's New All-electric Three (SG, D, Trans) A.C.		AW383
Mantovani A.C. Three (HF, Pen, D, Pen)		WM374
£15 15s. 1936 A.C. Radiogram (HF, D, Pen)	Jan 6	WM401
Four-valve: Blueprints, 1s. 6d. each.		
All Metal Four (2 SG, D, Pen)		WM329
Harris' Jubilee Radiogram (HF Pen, D, LF, P)	May '35	WM386

SUPERHETS.		
Battery Sets: Blueprints, 1s 6d. each.		
Modern Super Senior		WM375
Varsity Four	Oct. '35	WM395
The Request All-Waver	June '36	WM407
1935 Super Five Battery (Superhet)		WM379
Mains Sets: Blueprints, 1s. 6d. each.		
Heptode Super Three A.C.	May '34	WM359
"W.M." Radiogram Super A.C.		WM366

PORTABLES.		
Four-valve: Blueprints, 1s. 6d. each.		
Holiday Portable (SG, D, LF, Class B)		AW393
Family Portable (HF, D, RC, Trans)		AW447
Two H.F. Portable (2 SG, D, QP21)		WM363
Tyers Portable (SG, D, 2 Trans)		WM367

SHORT-WAVE SETS—Battery Operated.

One-valve: Blueprints, 1s. each.		
S.W. One-valver for America	15.10.38 (p.w.)	AW429
Roma Short-waver		AW452

Two-valve: Blueprints, 1s. each.		
Ultra-short Battery Two (SG det., Pen) F.b.	Feb. '36	WM402
Home-made Coil Two (D, Pen)		AW440

Three-valve: Blueprints, 1s. each.		
World-ranger Short-wave 3 (D, RC, Trans)		AW355
Experimenter's 6-metre Set (D, Trans, Super-regen)	30.6.34	AW438
The Carrier Short-waver (SG, D, P)	July '35	WM390
Four-valve: Blueprints, 1s. 6d. each.		
A.W. Short-wave World-Beater (HF Pen, D, RC, Trans)		AW436
Empire Short-waver (SG, D, RC, Trans)		WM318
Standard Four-valver Short-waver (SG, D, LF, P)	22.7.39 (p.w.)	WM383
Superhet: Blueprint, 1s. 6d.		
Simplified Short-wave Super		WM397

Mains Operated.		
Two-valve: Blueprints, 1s. each.		
Two-valve Mains Short-waver (D, Pen) A.C.	13.1.40 (p.w.)	AW433
"W.M." Long-wave Converter		WM380
Three-valve: Blueprint, 1s.		
Emigrator (SG, D, Pen) A.C.		WM352
Four-valve: Blueprint, 1s. 6d.		
Standard Four-valve, A.C. Short-waver (SG, D, RC, Trans)		WM391

MISCELLANEOUS.

S.W. One-valve Converter (Price 6d)		AW329
Enthusiast's Power Amplifier (1/6)		WM367
Listener's 5-watt A.C. Amplifier (1/6)		WM392
Radio Unit (2r.) for WM392 (1/-)		WM398
Harris Electrogram (Battery amplifier) (1/-)		WM399
De-Luxe Concert A.C. Electrogram (1/-)		WM403
New Style Short-wave Adapter (1/-)		WM388
Trickle Charger (6d.)		AW462
Short-wave Adapter (1/-)		AW456
Superhet Converter (1/-)		AW457
B.L.D.L.C. Short-wave Converter (1/-)		WM405
Wilson Tone Master (1/-)	June '36	WM406
The W.M.A.C. Short-wave Converter (1/-)		WM408

IMPORTANT RADIO BOOKS

by

RALPH STRANGER

THE OUTLINE OF WIRELESS

Deals with Matter and Energy, Electronic Currents, Magnetism, and Electro-Magnetism, Batteries and Accumulators, Wireless Communication and Broadcasting, Modern Valves, Wireless Signals, Wireless Receiving Circuits, Wireless Measuring Instruments, etc. Fully Illustrated.

Price 15/- net (by post 15/9)

THE MATHEMATICS OF WIRELESS

This Wireless writer makes even the most abstruse topics interesting—and amusing! The book deals with: Arithmetic, Algebra, Powers and Roots, Differential Calculus, Integral Calculus, Trigonometry, The Slide Rule, Logarithms, Efficiency, Curves and Graphs in Wireless.

Price 7/6 net (by post 8/-)

DICTIONARY OF RADIO AND TELEVISION TERMS

This helpful Dictionary not only covers Radio and Television, but also gives a large number of scientific terms of subjects allied to these two sciences. There are many special illustrations and diagrams.

Price 6/- net (by post 6/6)

Of Booksellers, or by post from—

GEORGE NEWNES, LTD.

(Book Department)

**TOWER HOUSE, SOUTHAMPTON STREET
LONDON, W.C.2**