

**As you are now the owner of this document which should have come to you for free, please consider making a donation of £1 or more for the upkeep of the (Radar) website which holds this document. I give my time for free, but it costs me around £300 a year to bring this document to you. You can donate here <https://blunham.com/Radar>, thank you.**

**Do not upload this copyright pdf document to any other website. Breaching copyright may result in a criminal conviction and large payment for Royalties.**

This document was generated by me, Colin Hinson, from a document held at R.A.F. Henlow Signals Museum which is believed to be out of copyright or Crown Copyright. It is presented here (for free) under the Open Government Licence (O.G.L.) if under Crown Copyright and this version of the document is my copyright (along with the Crown Copyright) in much the same way as a photograph would be. It should be noted that most of the pages are identifiable as having been processed by me. If you believe the original document to be under copyright, please contact me.

The document should have been downloaded from my website <https://blunham.com/Radar>, or any mirror site named on that site. If you downloaded it from elsewhere, please let me know (particularly if you were charged for it). You can contact me via my Genuki email page: <https://www.genuki.org.uk/big/eng/YKS/various?recipient=colin>

**You may not copy the file for onward transmission of the data nor attempt to make monetary gain by the use of these files. If you want someone else to have a copy of the file, point them at the website (<https://blunham.com/Radar>). Please do not point them at the file itself as it may move or the site may be updated.**

---

I put a lot of time into producing these files which is why you are met with this page when you open the file.

In order to generate this file, I need to scan the pages, split the double pages and remove any edge marks such as punch holes, clean up the pages, set the relevant pages to be all the same size and alignment. I then run Omnipage (OCR) to generate the searchable text and then generate the pdf file.

Hopefully after all that, I end up with a presentable file. If you find missing pages, pages in the wrong order, anything else wrong with the file or simply want to make a comment, please drop me a line (see above).

If you find the file(s) of use to you, you might like to make a donation for the upkeep of the website – see <https://blunham.com/Radar> for a link to do so.

*Colin Hinson*

*In the village of Blunham, Bedfordshire, UK.*

RESTRICTED

48,206

AIR PUBLICATION

2525C

VOLUME 1

PART 2

September, 1950

# AMES TYPE 21 Mk. 5

## TECHNICAL INFORMATION

### SITING, INSTALLATION, SETTING-UP AND SERVICING

Prepared by direction of  
the Minister of Supply

*A. T. Rowlands.*

Promulgated by Order  
of the Air Council

*J. H. Barmer.*

AIR MINISTRY

## NOTE TO READERS

The subject matter of this publication may be affected by Air Ministry Orders, or by "General Orders and Modifications" leaflets in this A.P., in the associated publications listed below, or even in some others. If possible, Amendment Lists are issued to correct this publication accordingly, but it is not always practicable to do so. When an Order, or leaflet contradicts any portion of this publication, the Order, or leaflet is to be taken as the overriding authority.



### LIST OF ASSOCIATED PUBLICATIONS

	A.P.
AMES Type 13 Mk. 5	2525X
AMES Type 14 Mk. 6	2525PC
Display unit Type 5	2897A
IFF Mk. 3A on AMES Type 13	2525Y
IFF Mk. 3A and 3G on AMES Type 14	2525PB
Monitor Type 33	2563 Chap. 34
Oscilloscope Type 10	2879T
Output tester Type 65	2896Y
Radio vehicle Type 467	2897T
Signal generator Type 53	2546C
Signal generator Type 106	2563S
Signal generator Type 108	2899A
Test set Type 102	2906C
Test set Type 172A	2906G
Test set Type 223A	2896G
Test set Type 288	2896AG
Transmitter-receiver Type TR.3561	2525L
Turning gear Type 3 (Similar to Type 52 and 53)	2886B
Wavemeter Type G82A	2899A
Wavemeter Type W.1649	2545F
20kVA Met.-Vick. Lister generating set	2526N

## INTRODUCTION

### Composition of convoy

1. AMES Type 21 Mk. 5 is a mobile ground radar station operating on a wavelength of 10 centimetres. The station is intended to provide facilities for ground-controlled interception of aircraft by fighters but can also be used to provide early warning of low-flying aircraft. Effectively

Radio vehicle Type 461C  
 Radio vehicle Type 462C  
 Radio vehicle Type 467E  
 Four radio vehicles Type 456C  
 Radio vehicle Type 100  
 Radio vehicle Type 150  
 Radio vehicle Type 436H

the equipment consists of an AMES Type 14 Mk. 6 plan-position station combined with an AMES Type 13 Mk. 5 height-finding station.

2. AMES Type 21 Mk. 5 is fully mobile and the convoy consists of the following vehicles :—

Height-finder aerial vehicle  
 Plan-position aerial vehicle  
 Operations vehicle  
 Power vehicles  
 VHF R/T transmitting vehicle  
 VHF R/T receiving vehicle  
 Spares and workshop vehicle

If the convoy is for use in tropical climates it will also include radio vehicle Type 181B which is a trailer containing refrigerating plant.

### Radio vehicle Type 461C

3. When in transit the aerial reflector is secured to the offside of the container. Inside the container are :—

Transmitter-receiver Type TR.3561	Radar transmitter, receiver, monitor and associated power supplies
Aerial turning gear Type 53	Aerial rotation
Transmitter Type T.3117	IFF A-band transmitter
Two receivers Type R.3118	IFF A-band receivers
Mixer unit Type 13	IFF A-band mixer

### Radio vehicle Type 462C

4. When in transit one end section of the aerial reflector is detached and stowed on the container roof. Inside the container are :—

Transmitter-receiver Type TR.3561	Radar transmitter, receiver, monitor and associated power supplies
Aerial turning gear Type 52	Aerial rotation
Transmitter Type T.3638	IFF G-band transmitter
Receiver Type R.3118B	IFF G-band receiver
Amplifier Type A.3175	IFF G-band RF amplifier
Transmitter Type T.3117	IFF A-band transmitter
Receiver Type R.3118	IFF A-band receiver

} Not used and may not be fitted

### Radio vehicle Type 467E

5. This vehicle contains the following equipment for the remote operation of the aerial vehicles :—

Display unit Type 5	Radar and IFF displays
Control unit Type 443	Control of the plan-position aerial rotation
Control unit Type 442	Control of the height-finder aerial rotation
Operations equipment	Telephone exchange, plotting tables, etc.

#### **Radio vehicles Type 456C**

6. Four of these vehicles are provided, two for each section of the convoy (that is, AMES Type 13 and AMES Type 14). Only one of each pair is in use at any one time, the other being held in readiness as a standby. Each vehicle contains a 20kVA Metrovick-Lister generating set which provides:—

230V, single-phase, 50 c/s, unregulated and regulated supplies

400V, three-phase, 50 c/s supply

In the case of the vehicle supplying AMES Type 13, both the 230V supplies are used, but in the case of that supplying AMES Type 14, only the regulated supply is used. The three-phase output is only used if radio vehicle Type 181B, fitted with cooling unit Type 4, forms part of the convoy.

#### **Radio vehicle Type 100**

7. This VHF transmitting vehicle contains two transmitters Type T.1131 with ancillary equipment.

#### **Radio vehicle Type 150**

8. This VHF receiving vehicle contains two receivers Type R.1132 with ancillary equipment.

#### **Radio vehicle Type 181B**

9. Radio vehicle Type 181B is a trailer which is only supplied when the convoy is intended for use in tropical climates; the trailer is towed by radio vehicle Type 467E during transit. The vehicle contains cooling unit Type 4 or 2 which supplies cold air to the operations vehicle.

#### **Circuit description of AMES Type 21 Mk. 5**

10. This publication (A.P.2525C, Vol. 1, Pt. 2) contains only siting, installation, setting-up and servicing information on AMES Type 21, Mk. 5. It does not contain a circuit description of the equipment and it is not intended to issue a Part 1 of this Volume. For circuit information reference should be made to the publications on AMES Type 13 Mk. 5 and AMES Type 14 Mk. 6 which are listed, with other associated publications, immediately following the Note to Readers.

**PART 2**

**LIST OF CHAPTERS**

**Note**—A list of contents appears at the beginning of each chapter

- 1 Siting** (pages 1 to 4 inclusive)
- 2 Installation** (pages 5 to 41 inclusive)
- 3 Setting-up** (pages 43 to 95 inclusive)
- 4 Servicing** (pages 97 to 147 inclusive)

# Chapter 1

## SITING

### LIST OF CONTENTS

<b>GENERAL CONSIDERATIONS</b>	<i>Para.</i>	<b>TECHNICAL CONSIDERATIONS</b>	<i>Para.</i>
<i>Introduction</i> ....	1	<i>General</i> .....	11
<i>Accessibility</i> ....	3	<i>Permanent echo clutter</i> ..	16
<i>Defence</i> ....	5	<i>Absorption by trees and buildings</i> ..	17
<i>Camouflage</i> .....	6	<i>Siting the aerial vehicles</i> ..	19
<i>Communications</i> ...	8	<i>Siting the height-finding aerial vehicle</i> ..	20
<i>Site layout</i> ..	9	<i>Siting the plan-position aerial vehicle</i>	21

### LIST OF ILLUSTRATIONS

	<i>Fig.</i>
AMES Type 21 Mk. 5: example of site layout ....	1

### GENERAL CONSIDERATIONS

#### Introduction

1. AMES Type 21 Mk. 5 ground radar stations are primarily intended to be used for purposes of ground-controlled interception but may also be used to provide early warning of low-flying aircraft. When choosing the most suitable site for the station its method of use must be considered, as the nature of the radar cover required in the two cases is different. The technical siting considerations are discussed in para. 11-22.

2. Other factors which must be considered when choosing a site are:—

- (1) Accessibility
- (2) Defence
- (3) Camouflage
- (4) Communications

#### Accessibility

3. Some of the vehicles in the convoy weigh as much as 7-8 tons and in consequence the installation of the station on very soft ground should be avoided. In any case, if the vehicles can be driven on to steel mats of the type used in airfield runway construction, much time and trouble will be

saved when the time comes to change site.

4. The ease with which vehicles can be driven in and out of the site should also be considered but the necessity for suitable camouflage must take precedence.

#### Defence

5. The local defence authorities, usually the area Army commander, should be consulted before choosing a site. There are usually very few suitable sites but the best plan is to select two or three. If the defence authorities then advise against that considered best for technical reasons, a second proposal can be made without loss of time.

#### Camouflage

6. Vehicles, cable runs and paths present the greatest difficulties when an attempt is made to camouflage a mobile ground radar convoy against detection from the air. If the best radar performance is to be obtained the aerial vehicles must be well clear of buildings, hedges, trees, etc. Consequently little can be done to make them invisible from the air but coloured camouflage netting used so that it tones with the surrounding features can be very effective.

If the station is used to provide early warning facilities there may be a large arc behind the station (for example, inland when looking over the sea) over which no cover is required. In this event an aerial vehicle can be sited close to a wood or building which is within the arc.

7. Cables, paths and the other vehicles in the convoy can be hidden by use of natural features, such as trees and hedges, or by the use of camouflage netting. Existing paths should be used, but where this is impracticable personnel should be made to use fixed routes between the vehicles so that the paths appear as innocuous as possible.

#### Communications

8. Consideration must be given to the availability of communication channels, existing or proposed. These may be land lines, radio-telephone, or wireless-telegraphy

links. To reduce the risk of interference the R/T station should be placed as far as possible from the radar station.

#### Site layout

9. When the site has been selected the aerial vehicles should be placed in position, as far apart as practicable, and the other vehicles dispersed. The distances between vehicles are determined by the lengths of the cables supplied. A maximum distance of 100 yards is possible between the operations and aerial vehicles and of 20 yards between the operations and power vehicles. Since the only link between the communications vehicles and the radar site is by land line, the two sites can be at least one mile apart.

10. Full details of the connections between vehicles are given in Chapter 2 but a suggested layout of the site is given in fig. 1.

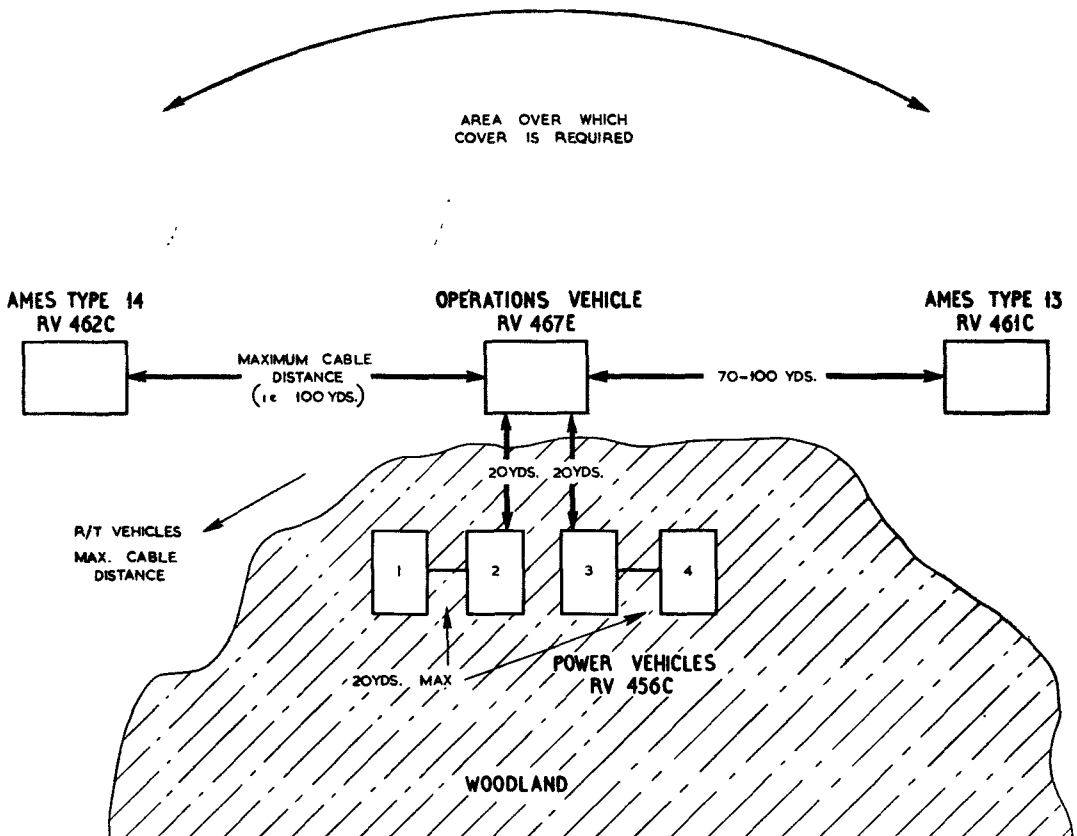

Fig. 1. AMES Type 21 Mk. 5: example of site layout

## TECHNICAL CONSIDERATIONS

### General

**11.** The vertical coverage of an aerial designed to operate at frequencies in the region of 3,000 Mc/s is only very slightly affected by the contours of the surrounding landscape. At this frequency there is little reflection of energy from the ground and the greater part of the energy received by the aerial is the result of reflection by a target. Thus the polar diagram of the aerial is unmodified by site irregularities and consistent all-round cover can be obtained.

**12.** The aerials of AMES Type 13 and 14 are designed so that they radiate the radio energy in narrow beams. In the former case the beam is narrow (approximately  $1\frac{1}{4}$  deg.) in the vertical plane in order to obtain satisfactory height discrimination. The beam from the plan-position aerial is narrow (approximately 1 deg.) in the horizontal plane in order to provide good discrimination in azimuth.

**13.** Because there is little ground reflection there are no considerable side lobes, as occur in the 200 Mc/s equipment, and there are no gaps in the polar diagram. In general, all objects which can be seen from the aerial position lie in the path of the radiated energy, and may give rise to permanent echo "clutter" on the displays.

**14.** At frequencies in the region of 3,000 Mc/s absorption of energy by trees and buildings may be serious and such objects can act as almost perfect screens. Consequently the presence of trees and buildings close to an aerial may often result in apparently poor performance in the direction of these objects.

**15.** The main technical difficulties to be overcome when choosing the site are in consequence:—

- (1) Reduction of permanent echo "clutter"
- (2) Avoidance of blind spots caused by absorption by objects.

### Permanent echo clutter

**16.** In spite of the fact that the reflector of the plan-position aerial is tilted backwards one degree, the lower part of the beam

still covers the earth's surface for a considerable distance. It is highly probable, therefore, that distant objects such as hills and towers will give rise to undesirable permanent echoes. The permanent echo produced on the display by such an object will obscure a target on the same range and bearing irrespective of its height. In this manner a large range of hills may cause a serious gap in the cover provided by the plan-position equipment.

### Absorption by trees and buildings

**17.** Any feature which subtends an angle greater than one degree at the aerial (one degree equals 5 feet per 100 yards approximately) will absorb energy and act as a screen, giving rise to blind spots in which targets cannot be detected. Isolated trees and buildings will not cause serious screening but if possible the aerial vehicles should be at a minimum distance of 70 yards from them.

**18.** The other vehicles in the convoy must by reason of the length of the cables lie within 100 yards of the aerials. Thus some screening by them is inevitable but can be reduced to a minimum by using the full lengths of the cables as shown in fig. 1.

### Siting the aerial vehicles

**19.** Generally the operations staffs will define the area in which the station must be installed, the actual siting being left to a siting party. Considerable time can be saved by the careful study of a large-scale map of the area beforehand. Two or three sites should be chosen from the map and a final decision made after visiting each site and comparing their respective merits from all points of view.

### Siting the height-finding aerial vehicle

**20.** The method of height-finding used in this equipment involves tilting the aerial beam and the display of target range and angle of elevation on a CRT. At all except small angles of elevation ground returns can be ignored, but these returns do determine the minimum angle of elevation at which accurate heights can be obtained. With no reflection from the ground this minimum angle is zero and with maximum reflection it is approximately  $\frac{3}{4}$  deg. (less over the sea). Broken ground scatters the reflections and

accurate heights can be obtained at almost zero elevation. It is therefore best to site the vehicle in a region of broken ground, but if this cannot be done it will still be possible to obtain accurate heights down to 3,000 ft. at a range of 50 miles.

*Siting the plan-position aerial vehicle*

**21.** Although ground returns only affect the performance slightly, siting is made more difficult by the necessity of avoiding permanent echo clutter. By placing the vehicle in the centre of a small depression clutter is reduced but only at the expense of low cover at medium ranges. On the other hand, a site on the crest of rising ground provides adequate low cover but usually too many permanent echoes.

**22.** When choosing the site it is usually necessary to compromise as shown by the following examples :—

(1) Siting in a bowl-shaped depression with rising ground for a distance of about 5 to 10 miles. Provided that the angle of slope does not exceed  $\frac{1}{2}$  deg. (500 ft. over 10 miles) there will not be a serious loss of low cover. Permanent echoes will not be troublesome beyond ranges of 10 miles unless from high ground.

(2) Siting on the crest of rising ground, or preferably a plateau. If the plateau is fairly flat and the ground gradually loses height at a distance of 10 miles, permanent echoes will not be unduly troublesome and low cover should be satisfactory.

## Chapter 2

# INSTALLATION

### LIST OF CONTENTS

	Para.		Para.
<b>INTRODUCTION</b>		<b>INSTALLATION OF RADIO VEHICLE TYPE 461C</b>	
General	1	General	31
Plugs and sockets used in the installation	3	Erecting the derrick frame	32
Inter-vehicle cabling	4	Lowering the reflector to the ground	33
<b>INSTALLATION OF POWER VEHICLES</b>		Erecting the support frame	34
General	10	Lifting the reflector and fitting it to the support frame	35
Power unit		Fitting the waveguide	36
Preliminary inspection	12	Fitting the magstrip and elevation drive mechanism	37
Fuel priming	13	Fitting the IFF aerial and feeders	38
Starting	14	Jacking system	42
Routine running inspection	15	Removal of cab	44
Switchboards		Internal installation	
Switch positions	16	Switchboard	45
Change-over procedure	17	<b>INSTALLATION OF RADIO VEHICLE TYPE 467E</b>	
Mains supply frequency adjustment	19	General	47
Temperature switch	20	Display units	49
<b>INSTALLATION OF RADIO VEHICLE TYPE 462C</b>		Internal cabling	51
General	21	Cabling schedule for AMES Type 21 Mk. 5	55
Removal of cab	22	Vehicle termination box	56
Erection of radar aerial reflector	23	Impedance matching junction box	57
Fitting the waveguide	24	Console No. 1	59
Checking reflector tilt	25	Console No. 2	61
Fitting the IFF aerial	26	Console No. 3	63
Jacking system	27	Jones socket jumpering	65
Internal installation		Fitting of control unit Type 442	69
Switchboard	29	Fitting of control unit Type 443	70
		Fitting of elevation switch	71
		G.P.O. battery charging apparatus	72
		Vehicle battery charging apparatus	73
		Elevation scan links on console No. 3	74
		Power units Type 377 and 451	75
		Installation of radio vehicle Type 181B	77

### LIST OF ILLUSTRATIONS

	Fig.		Fig.
Plugs and sockets: pin numbering	1	Diesel engine: near side view	9
Types of plugs and sockets	2	Diesel engine: cylinder head	10
Inter-vehicle cabling	3	Diesel engine: governor handle and locking pin	11
R.V.462C: termination box	4	R.V.462C in transit condition (left-hand side)	12
R.V.461C: termination box	5	R.V.462C in transit condition (right-hand side)	13
R.V.456C: stowage of cables at rear of switchboard	6	R.V.462C in operational condition	14
R.V.456C: switchboard	7	Sequence of operations for dismantling cab	15
Diesel engine: offside view	8	R.V.462C: method of assembly of reflector end section	16

## LIST OF ILLUSTRATIONS—contd.

	Fig.		Fig.
Aerial kit Type 219	17	R.V.461C: preparation for erecting paraboloid	29
Correct setting of aerial tilt	18	R.V.461C: erection, stage 1	30
R.V.462C: IFF aerial array	19	R.V.461C: erection of paraboloid	31
IFF Mk. 3A: arrangement of feeders	20	Aerial kit Type 222: assembled view	32
Operation of jacks on Mack chassis	21	R.V.461C: elevation drive mechanism	33
Jacking with board in position	22	R.V.461C: magflip assembly	34
TR.3561: switchboard	23	Aerial array Type 102	35
R.V.461C in transit condition	24	R.V.467E with R.V.181B on tow	36
R.V.461C in operational condition	25	R.V.467E with R.V.181B in working position	37
R.V.461C: assembly of winch before lowering reflector	26	R.V.467E: view towards front wall	38
R.V.461C: tackle in position for lowering paraboloid	27	R.V.467E: view towards rear wall	39
R.V.461C: lowering reflector	28	Termination box	40
		Elevation scan links on console No. 3	41
		Power units Type 377 and 451	42

## INTRODUCTION

## General

1. After the site has been selected the first task is to drive the various vehicles of the convoy into their allotted positions. It is then necessary to connect the inter-vehicle cables, erect the aerial systems, and carry out certain preliminary work inside the vehicles. Since it may be found necessary

to have lighting and power available during installation, instructions for bringing the power vehicles into operation are given in para. 10-20 of this chapter.

2. A typical site layout is shown in Chap. 1, fig. 1. The arrangement shown can be modified to suit local conditions, but it is

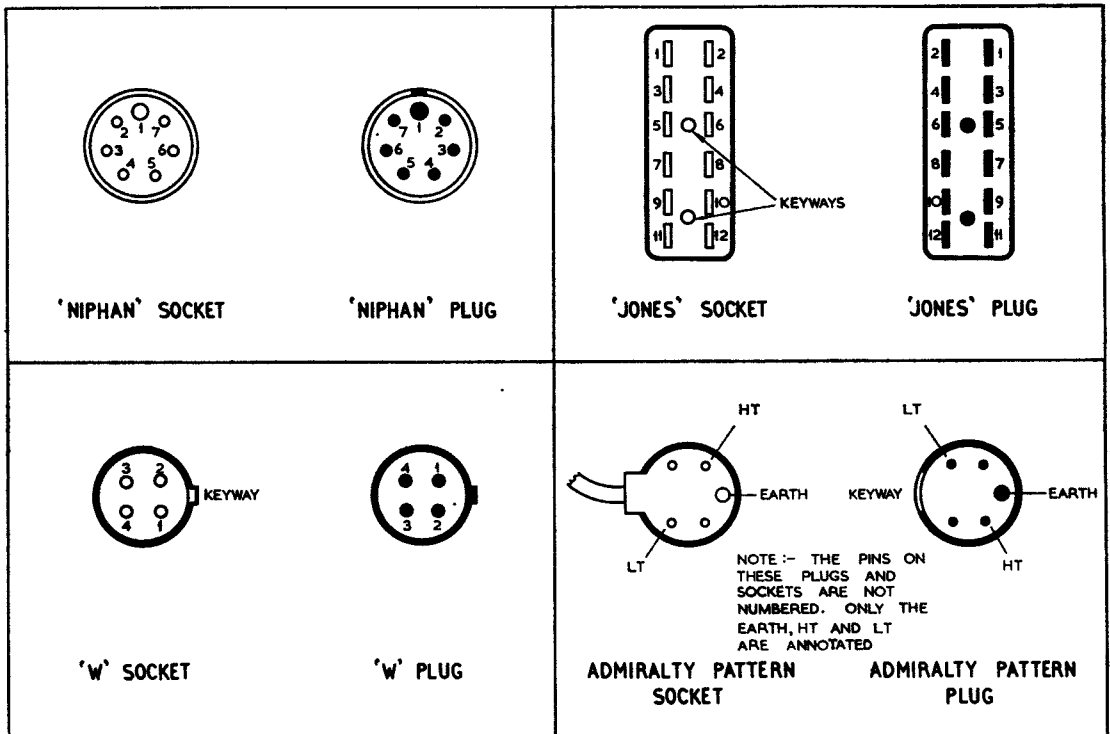
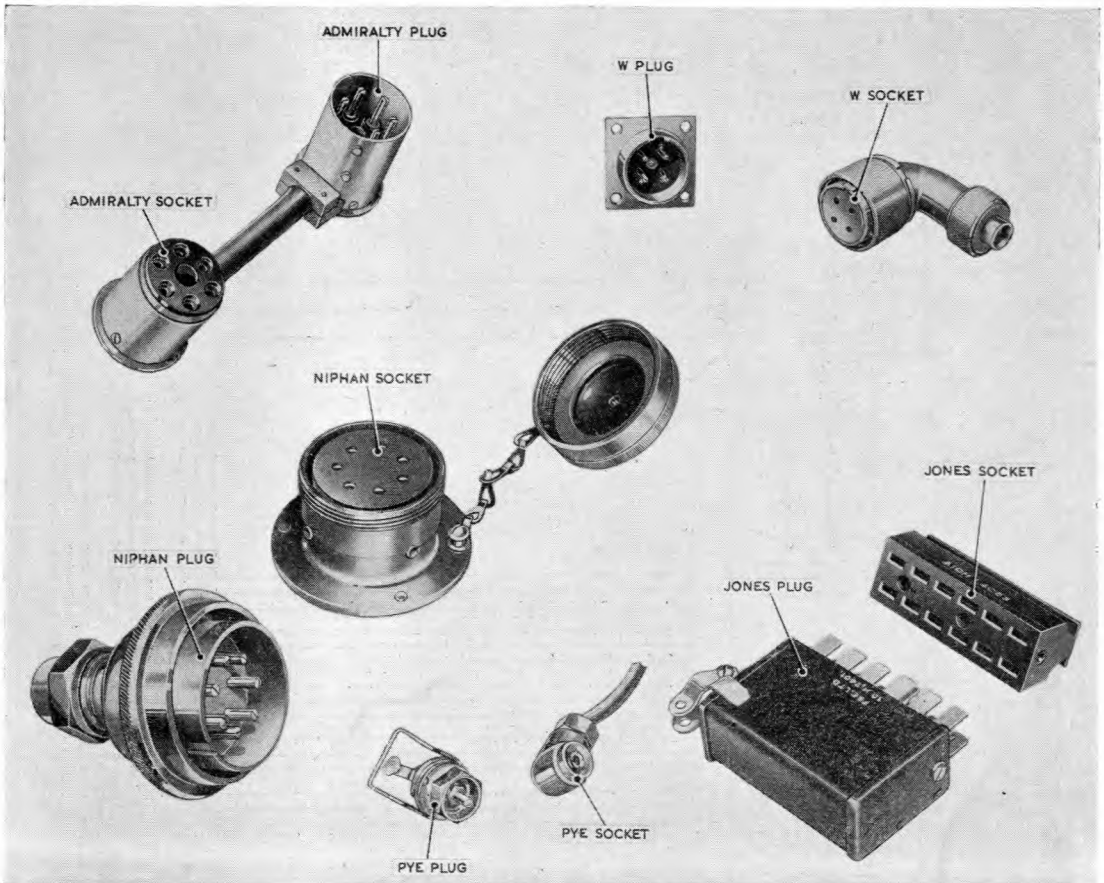

Fig. 1. Plugs and sockets : pin numbering



**Fig. 2. Types of plugs and sockets**

emphasised that the aerial vehicles should be at least 70 yards from any other vehicles or obstructions, unless these are situated in a region which is unimportant from an operational point of view.

#### **Plugs and sockets used in the installation**

3. Fig. 1 and 2 illustrate the various types of plug and socket used in the installation and should prevent confusion between them. Fig. 1 also shows the pin numbering system which is used on all the variations of each type of plug. In the case of the Jones plugs and sockets it is often difficult to read the numbers and in the case of the Niphan and Admiralty types the pins are not numbered. Reference to fig. 1 and 2 should solve any identification problems which occur during initial installation or servicing.

#### **Inter-vehicle cabling**

4. Cable kits Type 51 (AMES Type 14) and 52 (AMES Type 13) contain most of

the cables used in the installation and when not in use are kept on drums which during transit are stored in the power vehicles. The cables are rolled as follows:—

#### **Cable kit Type 51**

Drum No.	Cable No.
1	45, 46, 47, 51
2	48, 50, 52
3	43, 44
4	49

#### **Cable kit Type 52**

Drum No.	Cable No.
1	31, 33, 34
2	32, 40
3	35, 41, 42
4	36, 38
5	37, 39

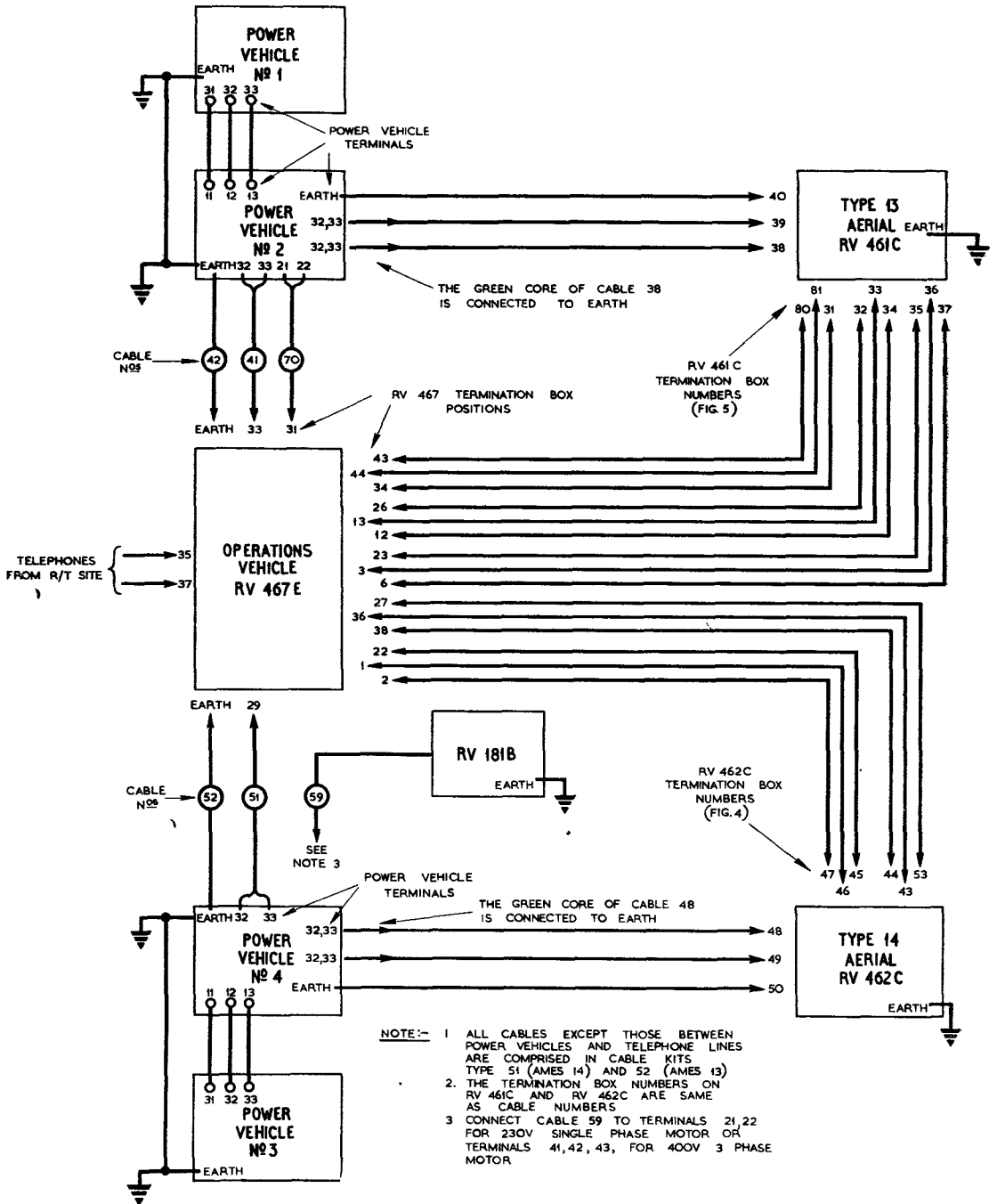

Fig. 3. Inter-vehicle cabling

5. In addition to the cable kits the following cables are also supplied :—

(1) Three IFF connectors (Numbered 53, 80 and 81).

(2) The connector for the refrigerating plant (No. 59) which is supplied with radio vehicle Type 181B.

(3) The cables for linking the power vehicles which are supplied with them.

(4) The telephone cables.

(5) Cable No. 70 which is supplied with radio vehicle Type 467.

6. There may not be identification numbers on the plugs and sockets of the aerial vehicle termination boxes but the correct connections can be determined by reference to fig. 4 and 5. In the case of the operations vehicle termination box the plugs and sockets are numbered, but not in agreement with the cable numbers ; the correct connections can be made by referring to fig. 13 which is a cabling diagram for the complete installation. This diagram should be followed carefully for it is very easy to plug some of the cables into wrong positions.

7. Some of the cables have a different type of termination at the two ends and to save time the cable drum should be placed near the appropriate vehicle before unwinding. Cables numbered 38, 39, 41, 48, 49 and 51 have 3-pin plugs at one end and lugs for connecting to the terminals of the power vehicles at the other. The six Uniradio cables (No. 36, 37, 46, 47, 80 and 81) have a right-angle socket at one end and a straight-entry socket for insertion in the aerial vehicle termination box at the other. Examination of the

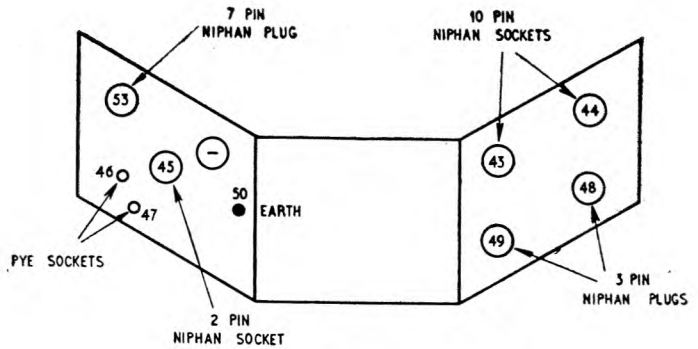

Fig. 4. R.V.462C : termination box

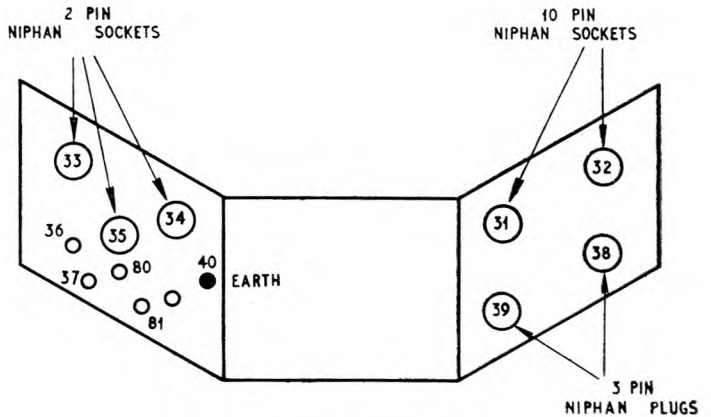

Fig. 5. R.V.461C : termination box

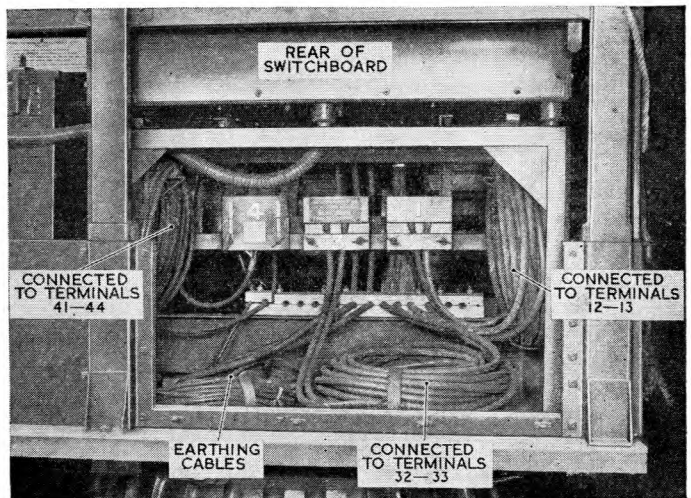

Fig. 6. R.V.456C : stowage of cables at rear of switchboard

cable ends before unwinding will determine the best position for placing the drum.

8. A short cable attached to an earthing spike is fitted to each power and aerial vehicle. Drive these spikes into the ground beside the respective vehicle.

9. The cables which are used to link each pair of power vehicles are permanently

wired to the switchboards and stowed as shown in fig. 6. In the AMES Type 21 installation three of these cables must be used to connect terminals 31, 32 and 33 on the switchboard of power vehicle No. 1 to terminals 11, 12 and 13 respectively on the switchboard of power vehicle No. 2. A similar arrangement must be made between power vehicles No. 3 and 4.

## INSTALLATION OF POWER VEHICLES

### General

10. Full details of the installation and operation of the power vehicles are given in the handbook supplied with each vehicle and in A.P.2526N, Vol. 1. Para. 11-20 describes only the preliminary work required to obtain power and lighting for the convoy and minor servicing details.

11. Before proceeding with the preliminary inspection first ensure that switch S1 on the switchboard (fig. 7) is in the OFF position and that the AUTO/HAND switch is at AUTO. Turn the voltmeter switch to position 3.

### Power unit

#### Preliminary inspection

12. Make a preliminary inspection of the power unit as follows:—

- (1) Water. Slacken the wing nuts holding the radiator cap. Check that the radiator is filled to a level above that of the top radiator connector. Shut the sluice valve (fig. 8) by turning it fully clockwise.
- (2) Air cleaner. Check the oil level by unscrewing the wing nut, removing the lid, and lifting up the filter. The correct level is marked on the inside of the container. Top up, using oil OMD260 H.D. 50 (Stores Ref. 34D/163) if the level is below the point of the arrow but do not overfill.
- (3) Engine sump (fig. 9). Check that the oil level is between the maximum and

minimum marks on the dipstick. If necessary, top up by pouring H.D.50 oil (Stores Ref. 34D/163) into the filler hole near the dipstick.

- (4) Fuel oil pump sump (fig. 8). Check that the oil level is between the maximum and minimum marks on the dipstick which is located at the engine side of the pump. Top up through the dipstick hole, if necessary, using oil H.D.50 (Stores Ref. 34D/163).
- (5) Cylinder heads (fig. 10). Fill these with oil to a level just below that of the

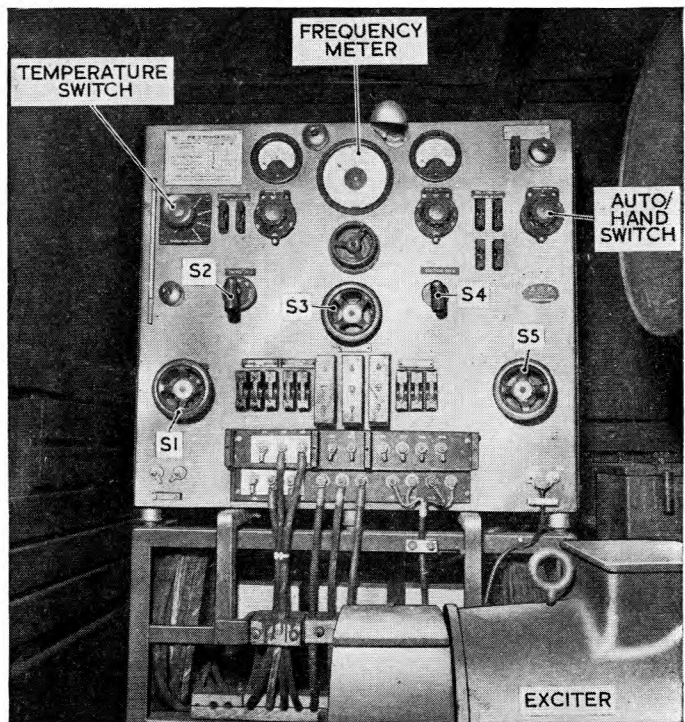

Fig. 7. R.V.456C : switchboard

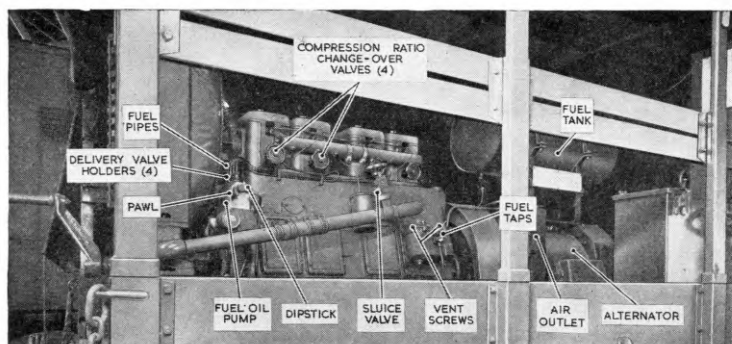

Fig. 8. Diesel engine : offside view

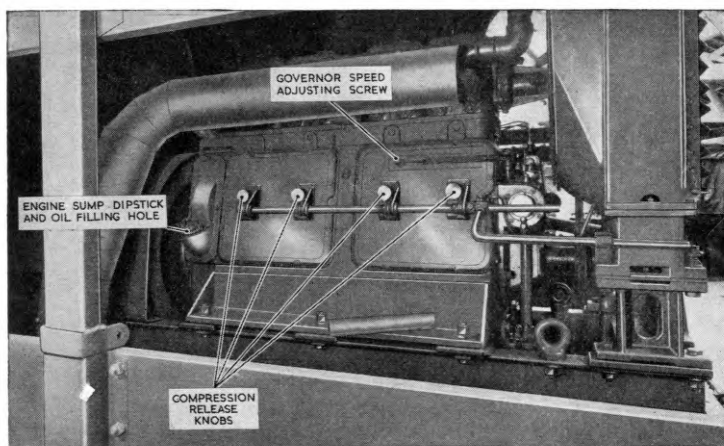

Fig. 9. Diesel engine : near side view

hollow of the studs through which the push rods operate. Fill the cups in the tops of the push rods.

- (6) Grease cups. There is one grease cup on each valve rocker assembly (fig. 10), and one each on the alternator, exciter unit, and water pump spindle. Check that each cup is filled with grease and give it two or three turns. Use grease

LG320 (Stores Ref. 34D/171) for the rocker arms and grease LG190 (Stores Ref. 34D/166) for the water pump.

- (7) Fuel. Check that the tank is full ; the correct fuel is 40 Diesel (Stores Ref. 34C/176). Use a clean container for transferring fuel and do not remove the strainer which is inserted in the filler hole. Turn on the fuel taps (fig. 8).

- (8) Alternator air outlet. Open the grill (*fig. 8*) and secure the arm with a wing nut.

#### Fuel priming

13. When the vehicles are first put into service it may be necessary to prime the fuel system as follows :—

- (1) Using a spanner, unscrew the vent screw on the top of the fuel filter (*fig. 8*). When oil flows out of the vent freely, re-tighten the screw.
- (2) Place the governor handle in the stop position (towards the radiator) with the locking pin in the slot (*fig. 11*). Attempt to start the engine before proceeding further.
- (3) Disconnect one of the fuel injection pipes from its delivery valve holder by unscrewing the union (*fig. 8*).
- (4) Remove the delivery valve holder and spring and raise the delivery valve slightly with the fingers. Fuel should now appear but hold the valve off its seat until all bubbles disappear.
- (5) Replace the valve, valve holder and spring, and reconnect the union.
- (6) Repeat (4) and (5) for the other three valves. Loosen the fuel pipe at the injector (*fig. 10*).
- (7) Place the governor handle in the start position (away from the radiator) by withdrawing the locking pin.
- (8) Push in the compression release knobs (*fig. 9*) and turn the starting handle until a steady and smooth flow of fuel appears at the injection union.

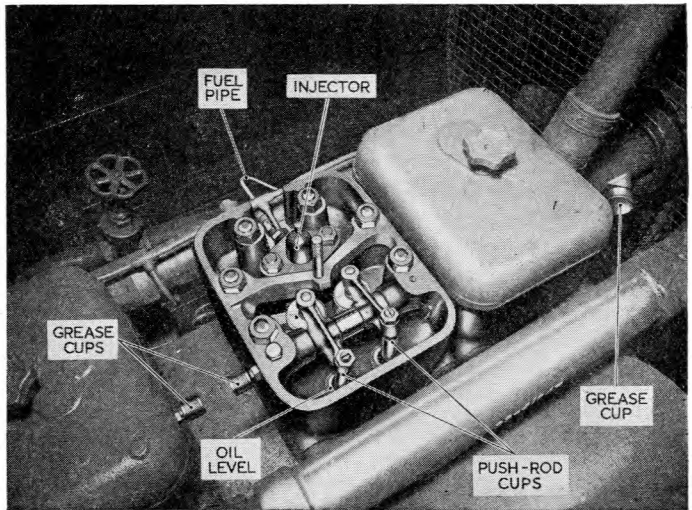

Fig. 10. Diesel engine : cylinder head

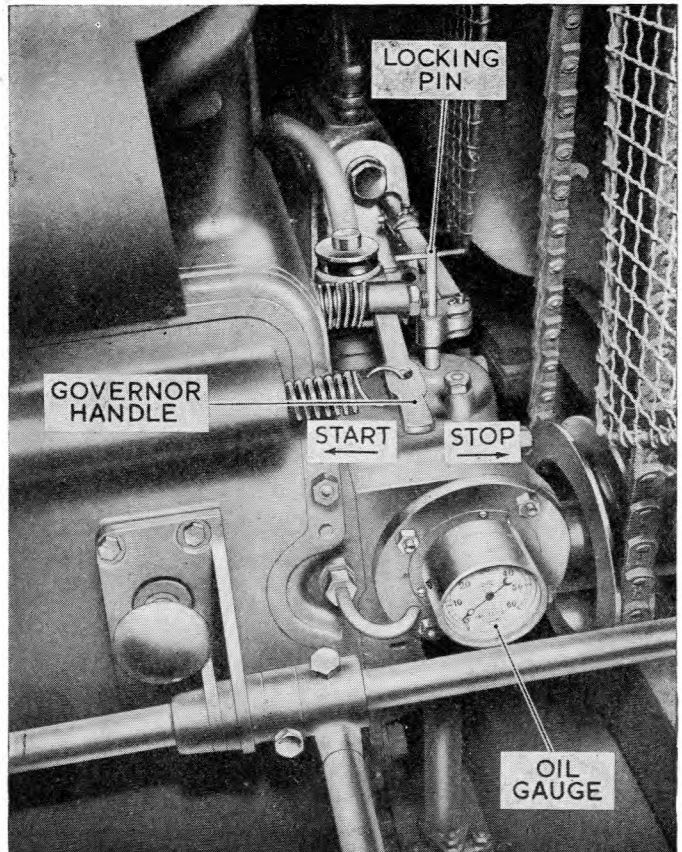

Fig. 11. Diesel engine : governor handle and locking pin

- (9) Re-tighten the union and repeat (8) for the remaining injection unions.

#### Starting

**14.** Proceed as follows :—

- (1) Push in the compression release knobs (*fig. 9*).
- (2) Set the governor handle to start, that is, raise the pin and allow the handle to spring back. Check that the pawl on the fuel pump is slack.
- (3) Screw in the four compression ratio change-over valves (*fig. 8*) tightly.
- (4) Turn the starting handle smartly; when a good speed has been attained push down the compression release handle and the engine should start. If the engine does not start after several attempts it is advisable to try the stand-by unit.

#### Routine running inspection

**15.** When the engine is running make the following checks :—

- (1) Running temperature. Check that this is between 160 and 175 deg. F.; the higher temperature is indicated by a red line on the thermometer. The diesel engine should be run really hot, but if the temperature rises above the higher limit open the sluice valve (*fig. 8*) a little.
- (2) Exhaust smoke. This is normally clear; if it is blue it is a sign that the engine is running at too low a temperature. If the smoke is black it is a sign that one or more of the injectors is stuck and the engine should be stopped and the stand-by unit used.
- (3) Oil pressure. Check that this is between 8 and 15 lb. per sq. inch as read on the gauge (*fig. 11*).
- (4) Compression change-over knobs. Check that these are fully screwed out.

#### Switchboards

##### Switch positions

**16.** Assuming that it is desired to run the power plant in No. 1 vehicle and to use that in No. 2 vehicle as a stand-by, the switches must be set as detailed here. A similar arrangement must be made for power vehicles No. 3 and 4.

#### Power vehicle No. 1 switchboard

Switch	Position
S1	B
S2	B
S3	On
S4	A
S5	B

#### Power vehicle No. 2 switchboard

Switch	Position
S1	B
S2	Off
S3	On
S4	Off
S5	B

#### Change-over procedure

**17.** When it is desired to run the plant in vehicle No. 2 instead of that in vehicle No. 1, the engine should be started and switch S1 on the switchboard of No. 1 vehicle changed from position B to position A.

**18.** It will be found advantageous to note the switch positions given in para. 16 and 17 on the ivorine plate attached to the top left-hand corner of the switchboard.

#### Mains supply frequency adjustment

**19.** The frequency of the alternator output voltage is proportional to the speed of the diesel engine. If the frequency is greater or less than 50 c/s, as indicated by the frequency meter (*fig. 7*), the engine speed must be adjusted appropriately by turning the governor (speed) control screw. The location of this screw can be seen from *fig. 9*.

#### Temperature switch

**20.** This switch (*fig. 7*) has a dial calibrated in steps of 10 deg. C and must be set according to the air temperature shown by the thermometer mounted on the switchboard. When starting the plant in cold weather it will be found best to set the switch several divisions below that corresponding to the air temperature and to bring it up to the correct position gradually during the first 30 minutes running.

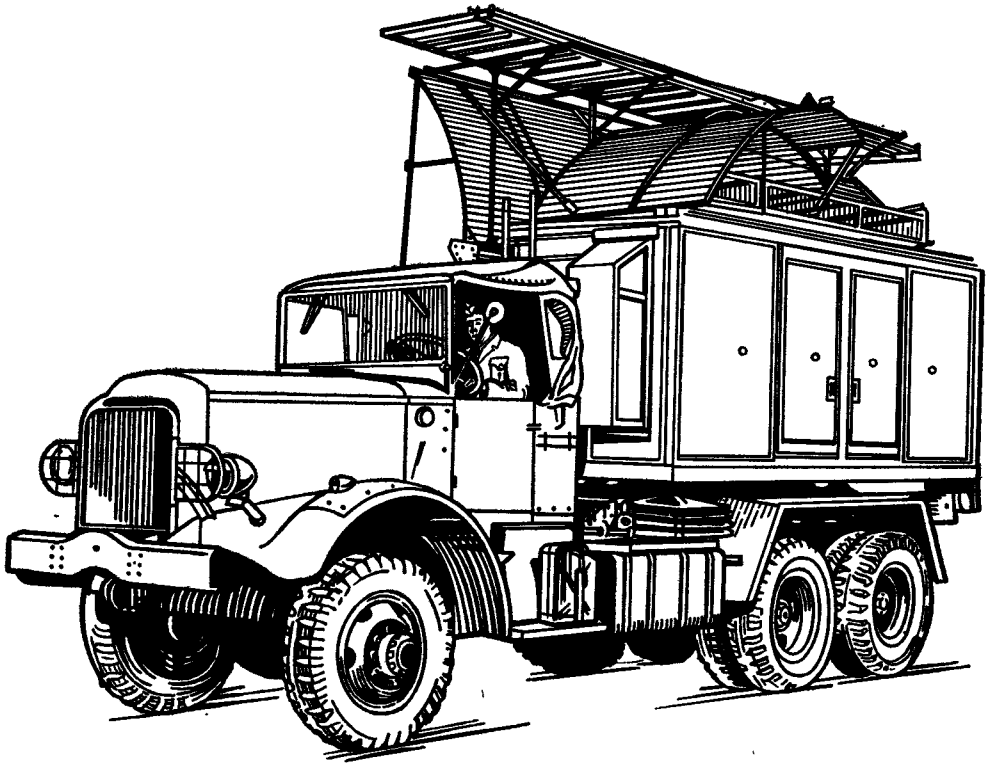

Fig. 12. R.V.462C in transit condition (left-hand side)

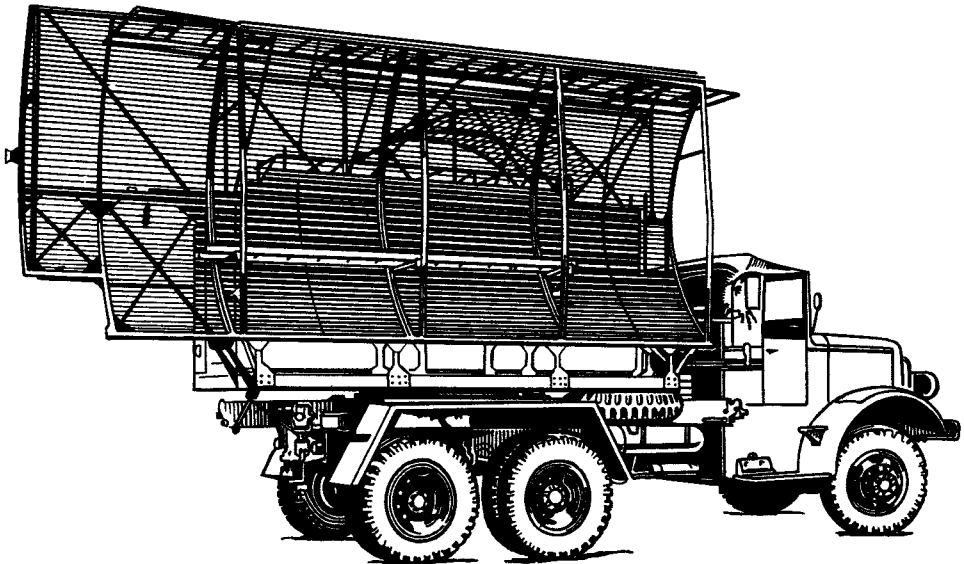

Fig. 13. R.V.462C in transit condition (right-hand side)

## INSTALLATION OF RADIO VEHICLE TYPE 462C

### General

**21.** Fig. 12 and 13 show the vehicle in transit condition and fig. 14 shows it when operational. The installation involves :—

- (1) Removing the cab of the vehicle.
- (2) Fitting the end section of the radar aerial reflector framework.
- (3) Fitting the waveguide.
- (4) Fitting the IFF aerial framework, unipoles and feeders.
- (5) Erecting the jacking system and leveling the container.
- (6) Completing certain internal installation.

### Removal of cab (fig. 15)

**22.** Proceed as follows :—

- (1) Roll the top cab cover to the windscreen.
- (2) Fold the windscreen forward with the cover underneath.
- (3) Detach and roll back the cab cover.
- (4) Release the back of the cab and cover-frame by undoing 9 bolts.
- (5) Remove the steering wheel by undoing the nut at the top of the steering column and lifting the wheel.

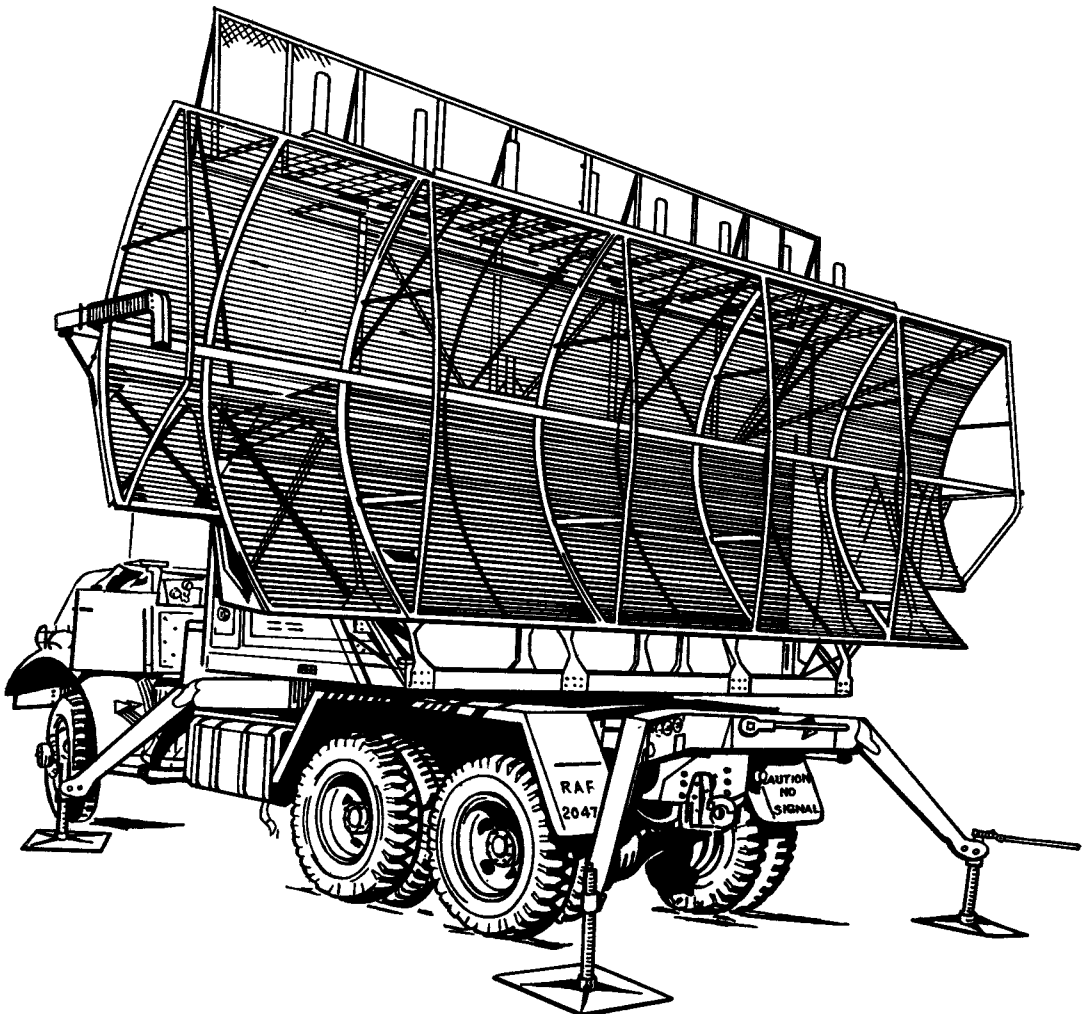

**Fig. 14.** R.V.462C in operational condition

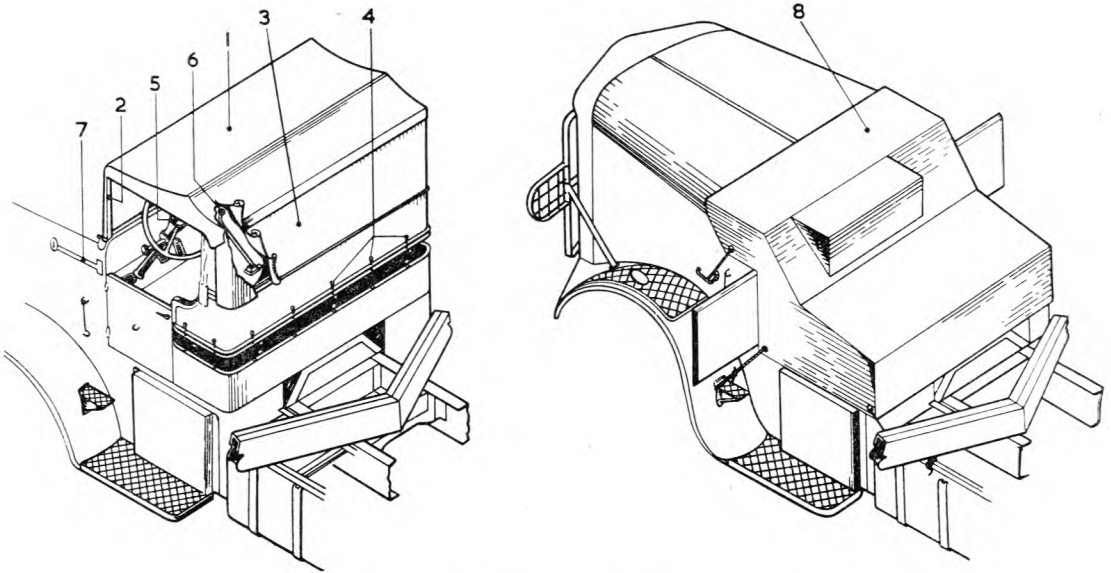

Fig. 15. Sequence of operations for dismantling cab

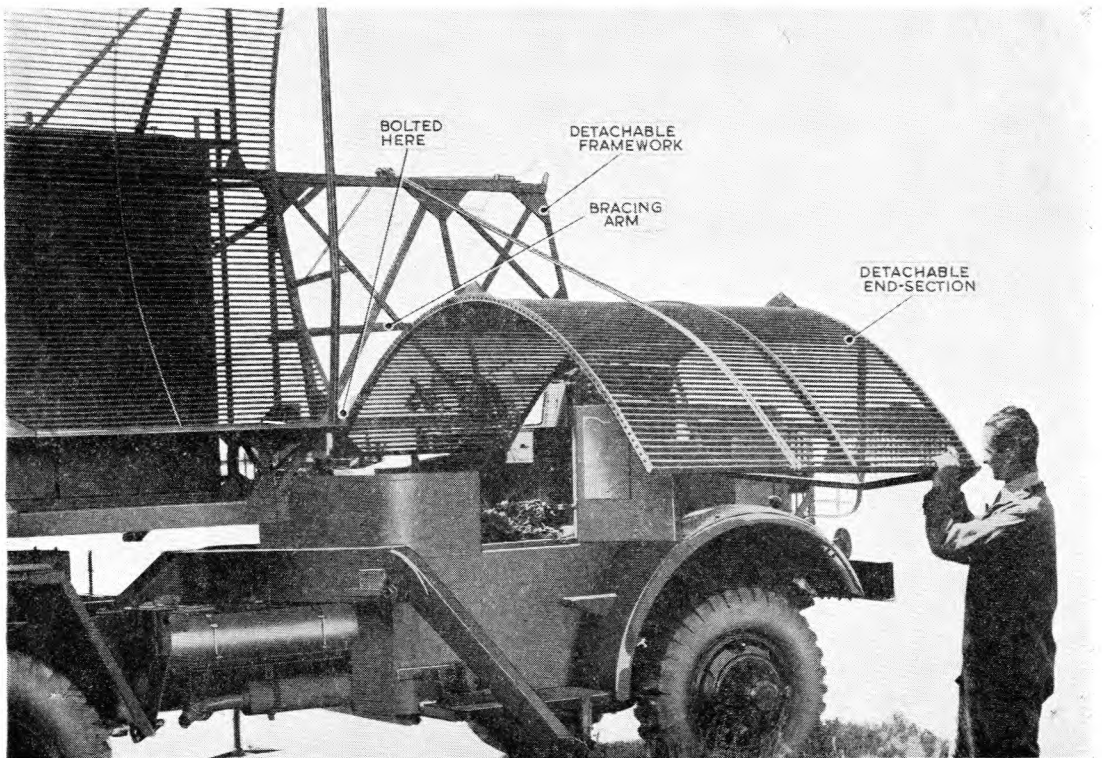

Fig. 16. R.V.462C : method of assembly of reflector end section

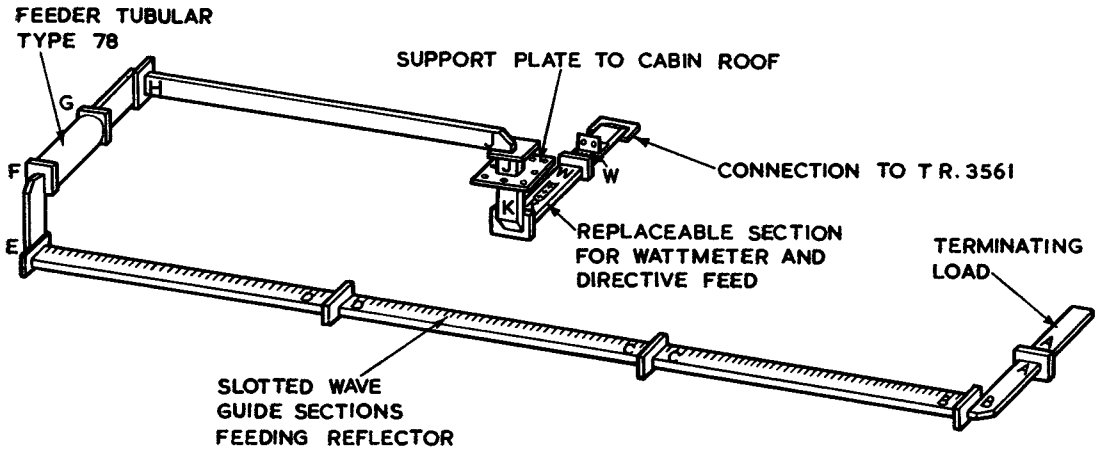

Fig. 17. Aerial kit Type 219

- (6) Place the gear lever in the position where it is furthest towards the front of the vehicle.
- (7) Fold the driving mirror against the bonnet.
- (8) Hook both doors open, fit the cover, and lash down as shown in fig. 15.

#### Erection of radar aerial reflector

23. Proceed as follows:—

- (1) Remove the jacking boards from the space between the cab and container.
- (2) Fit the framework which will support the detached end section of the reflector. Bolt in position as shown in fig. 16.
- (3) Fit the four bracing arms (one is shown in fig. 16). These are pre-set in length and are secured by means of Oddie fasteners.
- (4) Erect the end section of the reflector, taking care not to damage it.

#### Fitting the waveguide

24. The complete waveguide system is packed in a specially constructed box which is carried in one of the power vehicles. Each section of waveguide is lettered and must be assembled as shown in fig. 17. Ensure that gaskets Type 181 are fitted at the ends and between each section of the slotted waveguide. When assembled, mount the waveguide on the reflector supports and secure by means of the clamps provided. When doing this take care not to damage the Scotch acetate tape which covers the slots of the waveguide and prevents ingress of moisture.

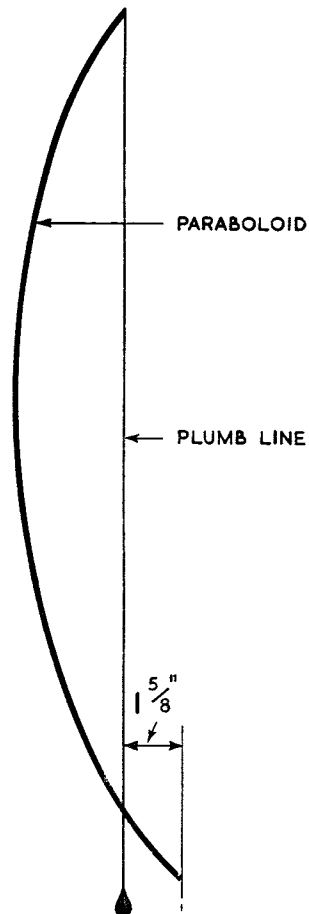

Fig. 18. Correct setting of aerial tilt

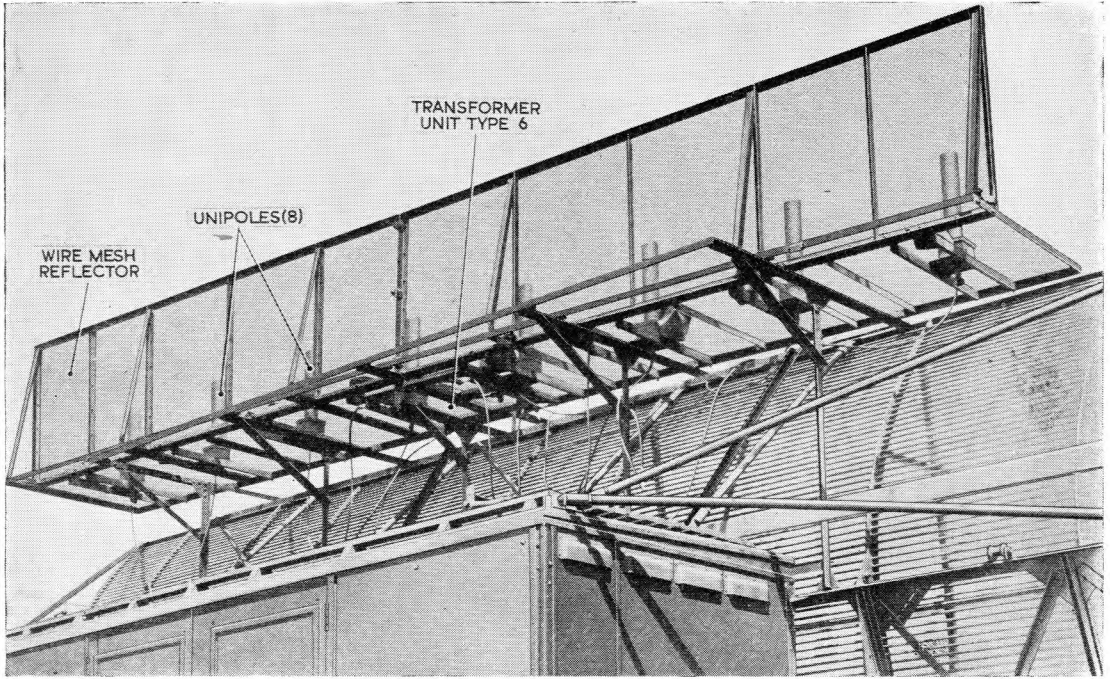

Fig. 19. R.V.462C : IFF aerial array

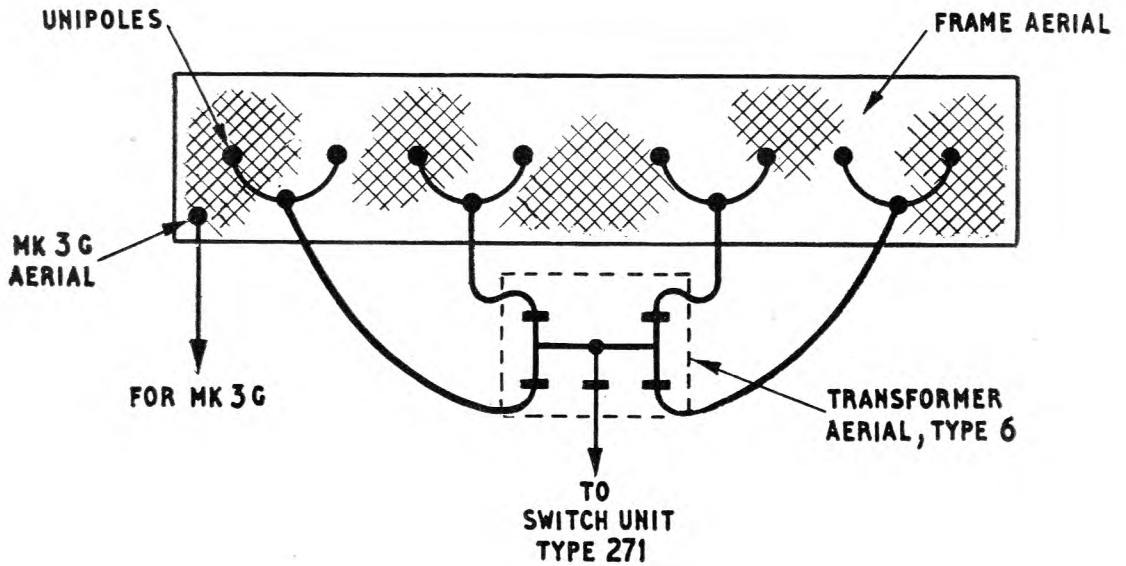
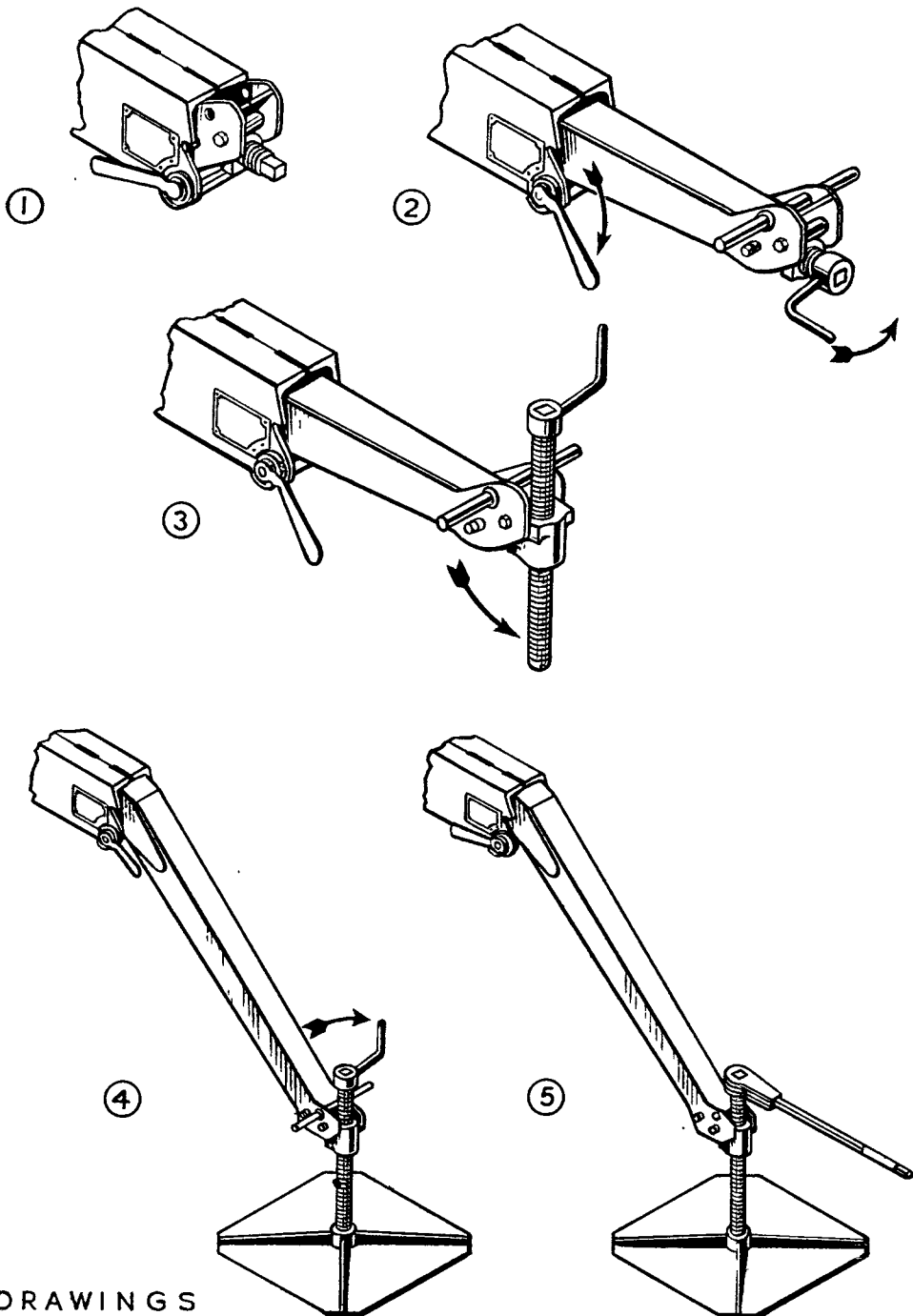

Fig. 20. IFF Mk. 3A : arrangement of feeders



DRAWINGS  
ARE NUMBERED  
IN OPERATIONAL  
SEQUENCE

Fig. 21. Operation of jacks on Mack chassis

### Checking reflector tilt

25. The reflector of the AMES Type 14 aerial is permanently tilted backwards at an angle of one degree to the vertical; this should be checked as follows:—

- (1) Attach a plumb line to the outer edge of the top of the reflector as shown in fig. 18.
- (2) Check that the line passes a point  $1\frac{5}{8}$  in. behind the outer edge of the bottom of the reflector.
- (3) Repeat (2) with the aerial facing in different directions.

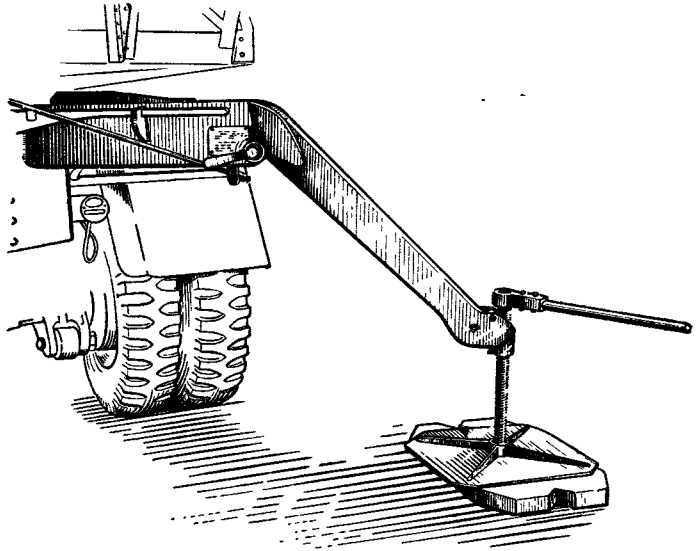

Fig. 22. Jacking with board in position

### Fitting the IFF aerial

26. Proceed as follows:—

- (1) Remove all the equipment from the container roof except the IFF aerial framework.
- (2) Bolt the IFF aerial framework in position as shown in fig. 19.
- (3) Unpack the 10 unipoles from their stowage box inside the container and screw them into their sockets as shown in fig. 19.
- (4) Bolt on the IFF feeder transformer and connect the feeders (fig. 20).

### Jacking system

27. A system of screw jacks enables the chassis to be levelled. It is not intended that the jacks shall be used to lift the chassis from the ground but that they shall take the weight of the rotating cabin and ensure that the turntable is level. The system is the same on radio vehicles Type 461C and 462C. The jack handles are located in two boxes attached to the rear jack arms.

28. Fig. 21 shows the sequence of operations and fig. 22 shows the jack arm and jacking board in position. Proceed as follows:—

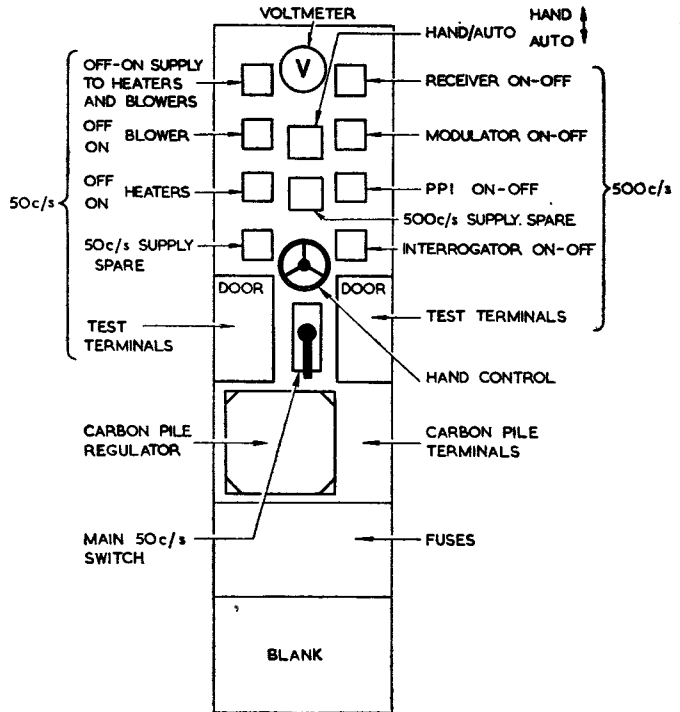

Fig. 23. TR.3561 : switchboard

- (1) Pull the lever up, and through 180 deg., to release the jack arm.
- (2) Withdraw the arm about one foot.

- (3) Fit a crank handle to the jack and unwind until the jack will swing into a vertical position.
- (4) Place a base plate at a distance of 3 ft. from the vehicle in line with the jack arm.
- (5) Withdraw the jack arm to its full extent and lower.
- (6) Fit the base plate and lock the jack arm in position by turning the lever back to its original position.
- (7) Screw up the jack until the weight of the cabin is taken up.
- (8) Remove the crank handle, fit a ratchet handle and rotate the jack spindle two turns.
- (9) Repeat (1) to (8) for the remaining three jacks.
- (10) Rotate the cabin by hand and observe the spirit-level behind the selsyn motor on the turning column inside the container.

- (11) Note the azimuths at which the spirit-level indicates a slope and correct by adjusting the appropriate jacks.

#### Internal installation

##### Switchboard (fig. 23)

29. On the right of the voltage regulator box below the AC SUPPLY SWITCH is a plate bearing instructions to be followed when different types of regulator are fitted. The regulator used in AMES Type 21 Mk. 5 will probably be of pattern W.4917, in which case remove the plate to the right of the regulator by removing four screws. Check that a lead is connected to the terminal marked COM and replace the plate. Remove the cover over the terminal box on the regulator and check that the terminal marked COM is connected. Open the regulator door and check that a link marked A-B shorts the COM terminals; close the door and replace the terminal box cover.

30. If a regulator of pattern W.1698 is fitted there is no link in the regulator and the connection between the COM terminals on each terminal strip is omitted.

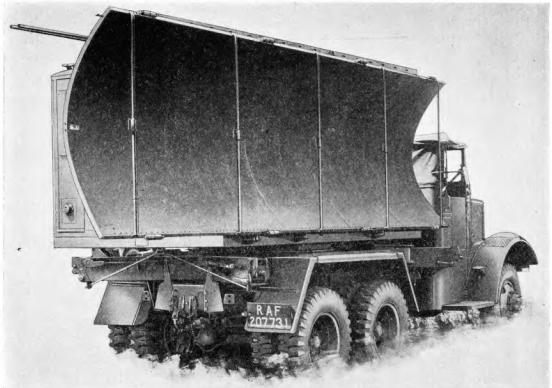

Fig. 24. R.V.461C in transit condition

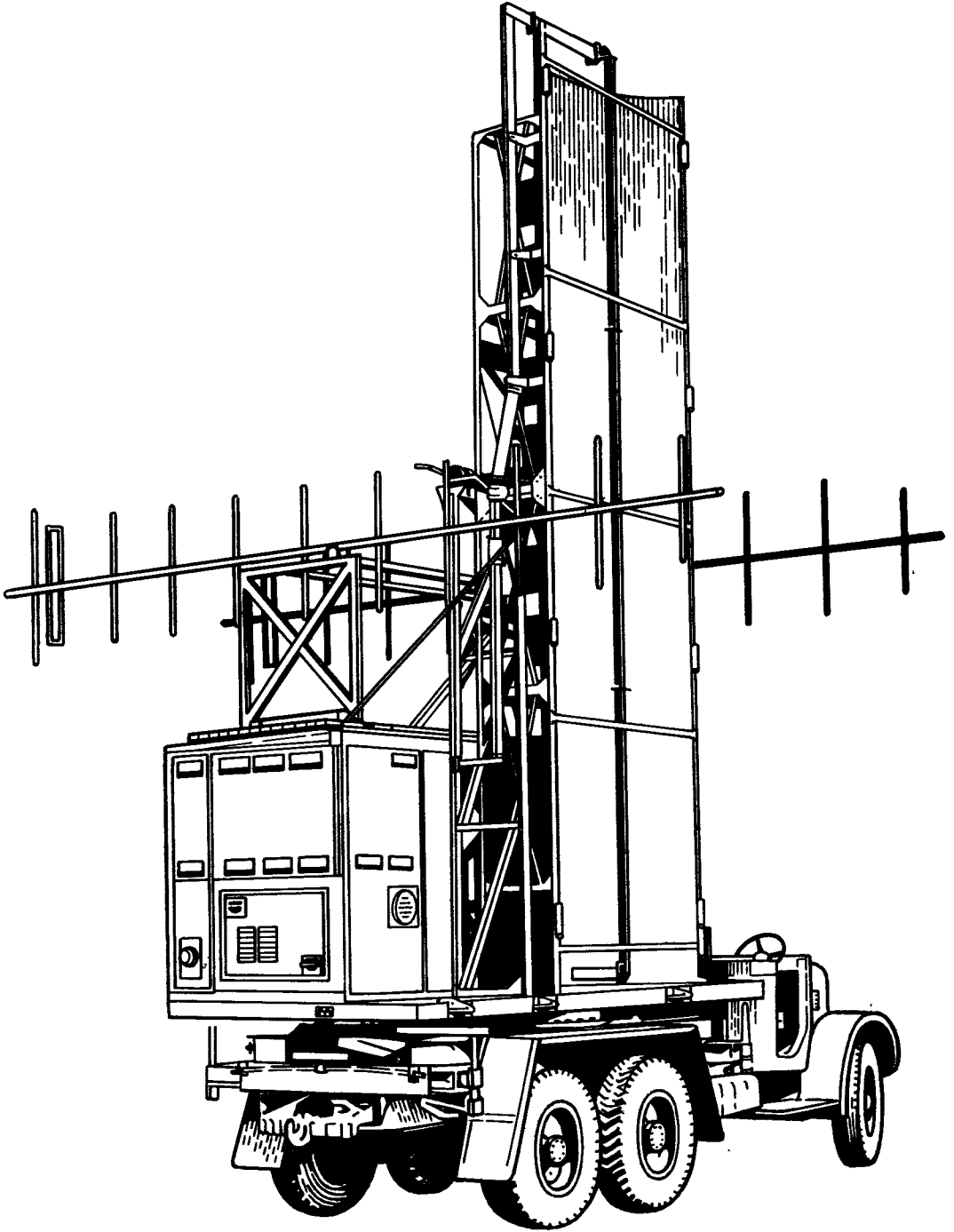

Fig. 25. R.V.461C in operational condition

## INSTALLATION OF RADIO VEHICLE TYPE 461C

### General

31. Fig. 24 shows the vehicle in transit condition and fig. 25 shows it when operational with the aerial erected. The installation involves :—

- (1) Erecting the derrick frame on the roof of the container.
- (2) Lowering the reflector to the ground.
- (3) Erecting the support frame.
- (4) Lifting the reflector and fitting it to the support frame.
- (5) Fitting the waveguide.
- (6) Fitting the elevation drive mechanism and assembling the magslip.
- (7) Fitting the IFF aerals and feeders.
- (8) Removing the vehicle cab.
- (9) Installing the jacking system and levelling the container.
- (10) Completing certain internal installation.

### Erecting the derrick frame

32. Erect the derrick frame as follows :—

- (1) Remove the ladder and the two wooden stays from their transit positions on top of the reflector.
- (2) Remove the shackle securing the reflector (fig. 26) ; the reflector will not fall.
- (3) Remove the IFF aerial rods and disconnect the IFF feeders from their dummy transit sockets on top of the container.
- (4) Lift up the two hinged sections of the IFF aerial supporting framework and fit one of the wooden stays between these sections at the back of the container remote from the reflector (fig. 25).
- (5) Unstrap the triangular section of the winch framework from the roof. Turn it over and bolt in position. The swinging legs of the frame fit into the

outer slots of the brackets (fig. 26) and the legs of the pulley section fit into the inner slots. Fig. 27 shows the erection complete to this stage.

**Lowering the reflector to the ground (fig. 26 and 28)**

33. Proceed as follows :—

- (1) Pass the winch cable over the pulley and attach the hook to the sling at the back of the reflector (fig. 26).
- (2) Keeping the winch cable fairly taut, push the reflector forward on its hinges until it is at the point of balance.
- (3) Take the weight of the reflector with the winch and lower the reflector on to

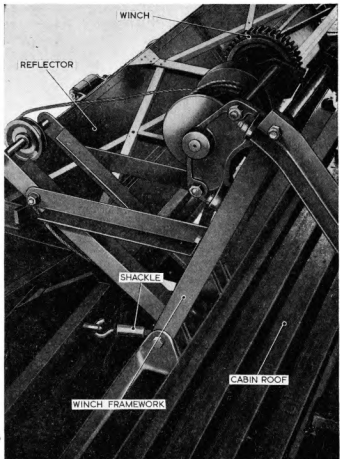

Fig. 26. R.V.461C : assembly of winch before lowering reflector

DERRICK FRAME WITH  
EXTENSION AND WINCH  
ERECTED

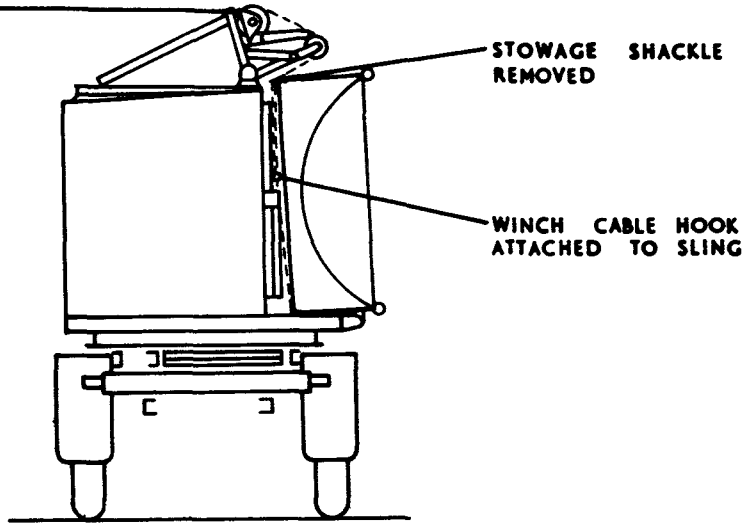

Fig. 27. R.V.461C : tackle in position for lowering paraboloid

jacking boards placed on the ground to receive it.

- (4) Transfer the winch cable to the staple at the centre of the side of the reflector nearest the chassis. Remove the sling.
  - (5) Take the weight of the reflector again with the winch and remove the hinge pins which secure the reflector to the chassis.
  - (6) Lower the reflector to the ground completely.
- (2) Pass the winch cable over the derrick pulley, behind the second pulley on the reflector, and attach the hook to the lifting bracket on the winch support frame.
  - (3) Lift the reflector until it is horizontal and support it by an oil drum or box.
  - (4) Fit the section of waveguide which passes down the centre line of the reflector. Each section of waveguide is lettered and the assembly is shown in fig. 32. Take care not to damage the tape covering the slots in the waveguide and ensure that gaskets Type 181 are fitted at the ends and between each section of slotted waveguide.

#### Erecting the support frame

**34.** With the reflector on the ground, remove the members of the support frame. Erect the members and the two diagonal stays as shown in fig. 29 and remove the vertical drive shaft. Lift the winch assembly complete on to the top of the derrick frame.

#### Lifting the reflector and fitting it to the support frame (fig. 30 and 31)

**35.** Move the reflector so that it is in line with the support frame, that is, at right angles to the vehicle, and proceed as follows :—

- (1) Lift one end of the reflector and secure it to the chassis by means of hinge pins placed through the brackets (fig. 30).
- (5) Hoist the reflector until it is in the pivot position and bolt the two flexible bearings to the support frame (fig. 31). If the reflector does not enter the support frame squarely correct by adjusting the turnbuckles on the diagonal stays.
- (6) Check that the bolts holding the bearings are secure and remove the winch cable, attaching the hook to the bracket on the winch framework.

#### Fitting the waveguide

**36.** Complete the assembly and erection of the waveguide (fig. 32).

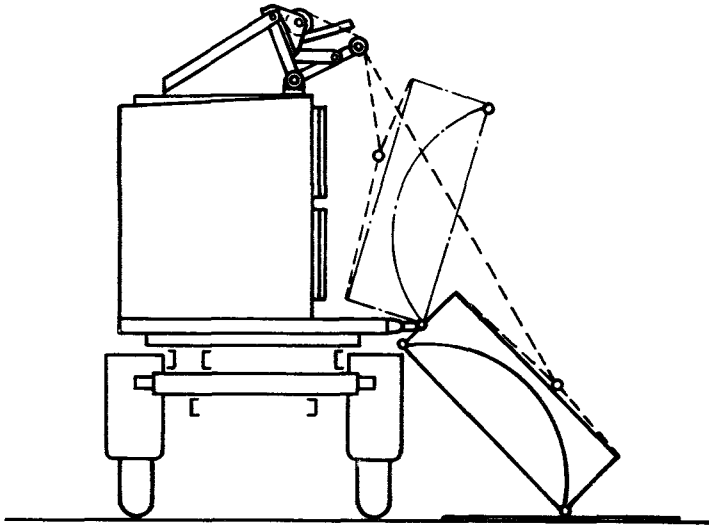

R.V. 461-C LOWERING STAGE 1

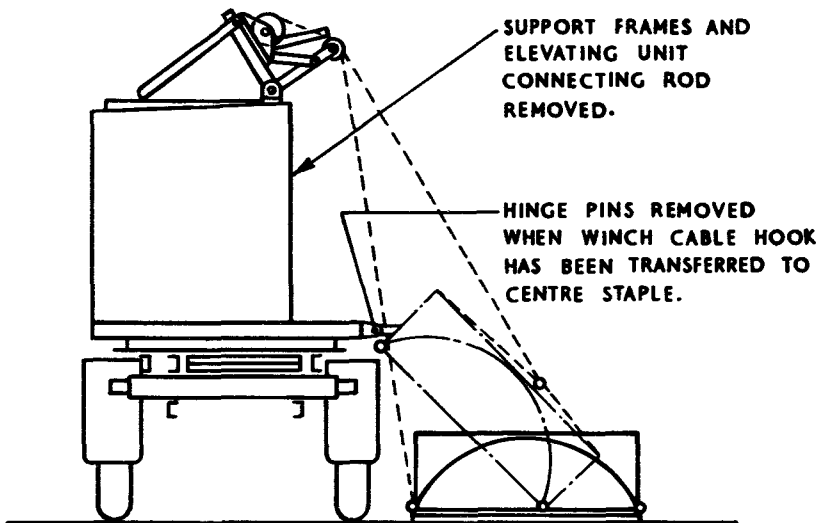

R.V. 461-C LOWERING, STAGE 2

Fig. 28. R.V.461C : lowering reflector

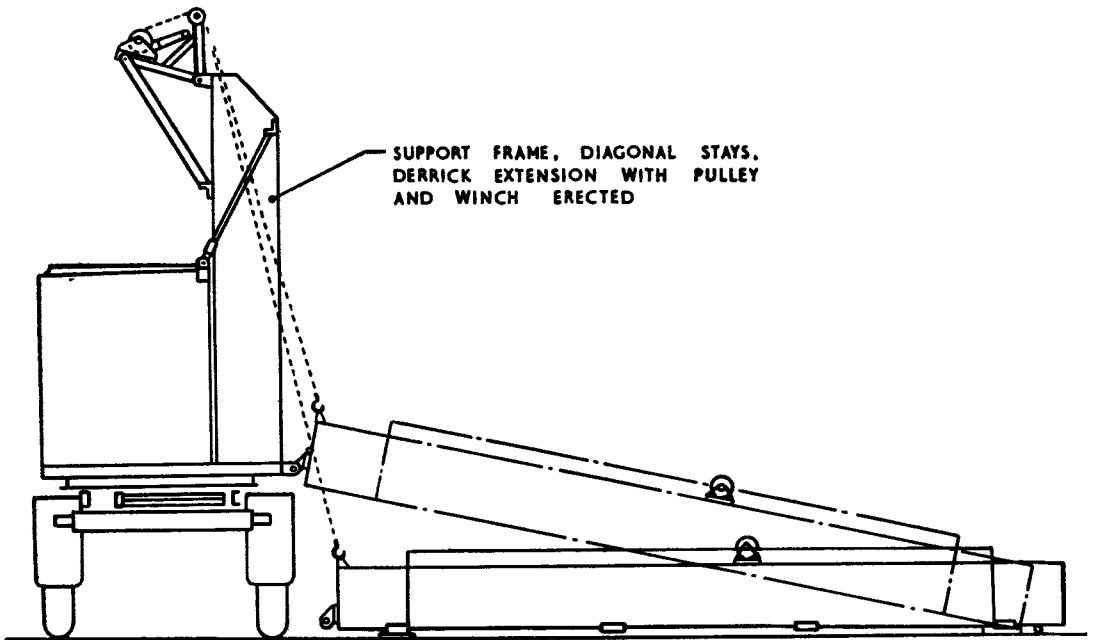

Fig. 29. R.V.461C : preparation for erecting paraboloid

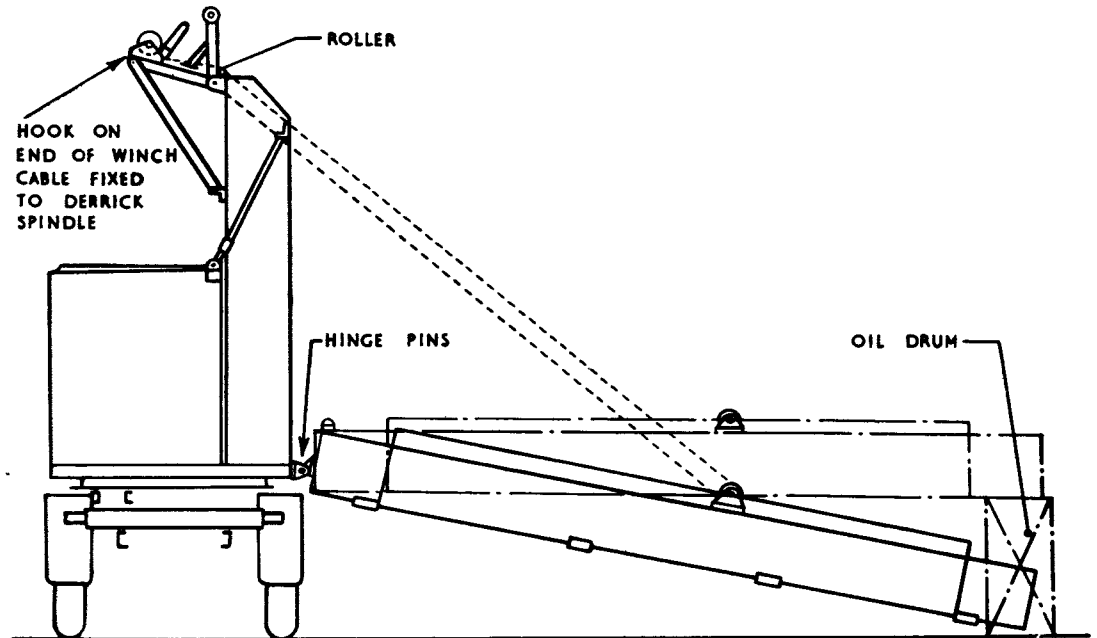

Fig. 30. R.V.461C : erection, stage I

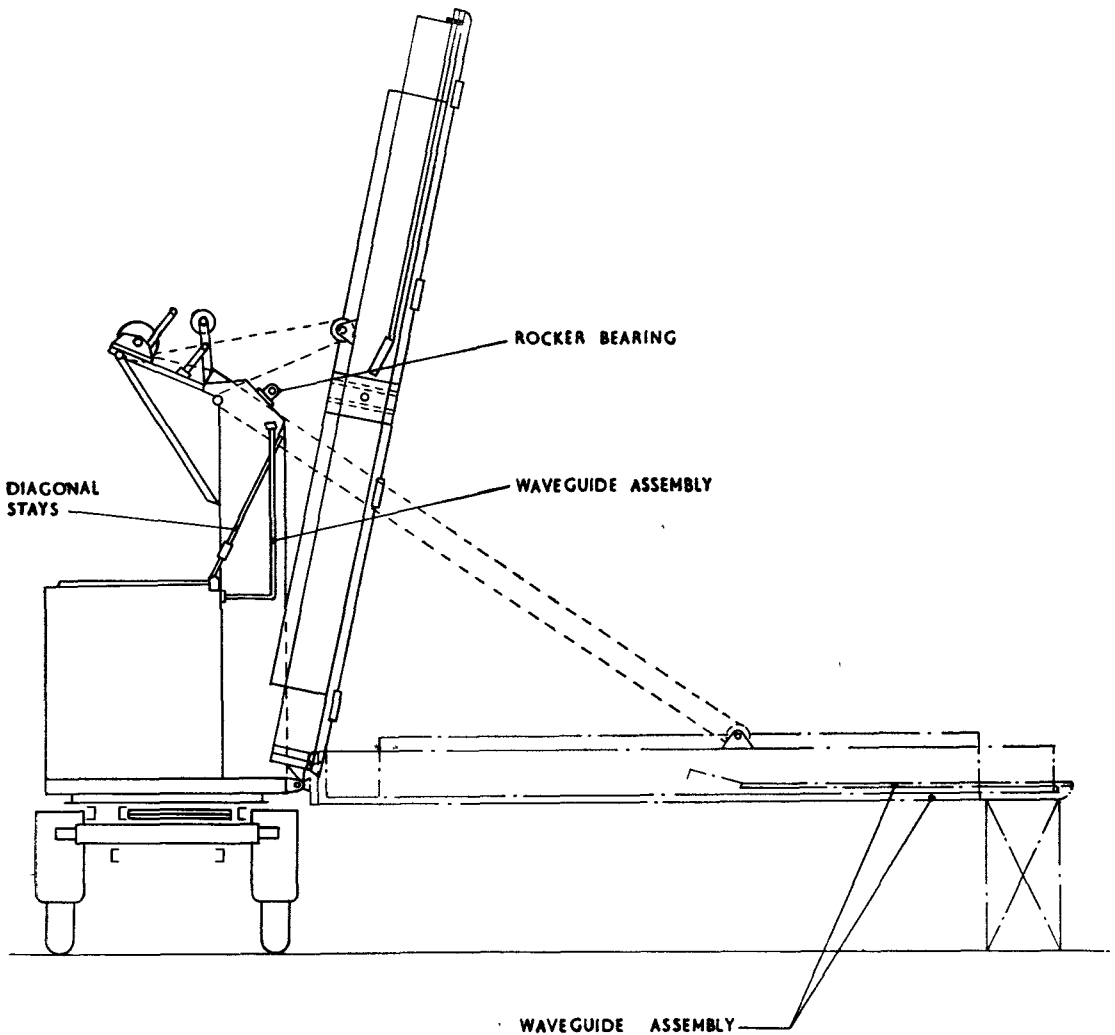

Fig. 31. R.V.461C : erection of paraboloid

#### Fitting the magclip and elevation drive mechanism

37. Proceed as follows:—

- (1) Fit the magclip beneath the right-hand pivot bearing as seen from the front.
- (2) Connect the two Uniradio connectors between X and Y and between A1 and A2. Plug the cable into the left-hand 5-pin Niphan socket (*fig. 33*). The radiation meter lead is not used.
- (3) Fit the magclip operating arm (*fig. 34*).
- (4) Remove the erection hinge pins so that the bottom of the reflector is free.

- (5) Remove the motor assembly from its transit position and bolt it into the position shown in *fig. 33*.
- (6) Fit the elevation drive shaft between the motor drive shaft and the reflector.
- (7) Connect the cable to the right-hand Niphan socket (*fig. 33*).

#### Fitting the IFF aerial and feeders

38. Fit the second horizontal cross member between the hinged frameworks. The fitting of the first member is described in para 32(4). Assemble the dipole, reflector, and nine directors on each aerial as described in para. 39 and 40.

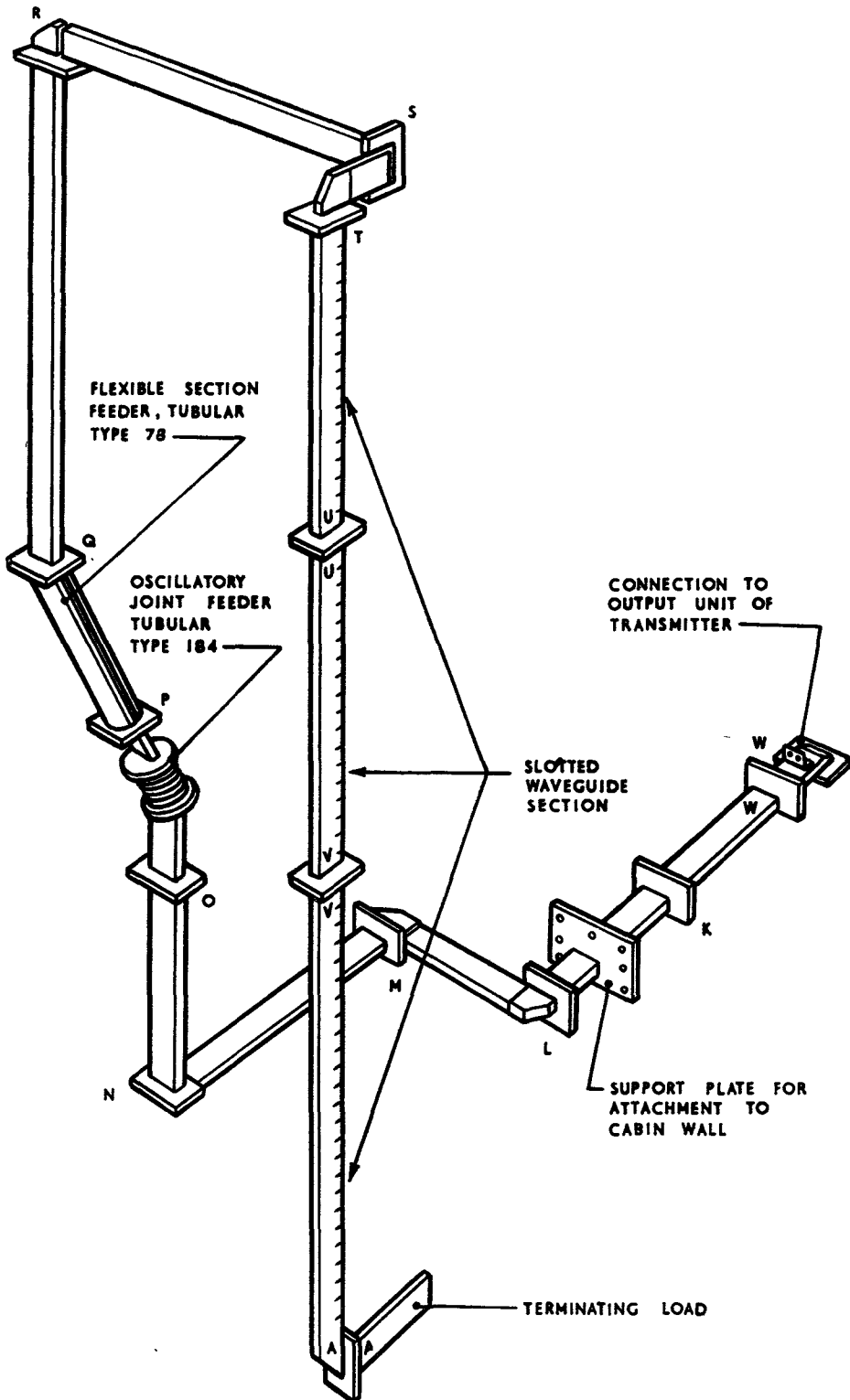

Fig. 32. Aerial kit Type 222 : assembled view



Fig. 33. R.V.461C : elevation drive mechanism

**39.** The assembly of the aerials is best done on the ground. First fit the reflector element, which is the longest rod, taking care to fit it at the correct end of the tube. Fig. 35 shows the construction of one aerial; the nine director elements are spaced at equal intervals from the dipole and from each other, but the reflector is much nearer the dipole than is the first director. The rods are fitted with a ring to ensure that they are clamped symmetrically in the tube. Consequently, put the longest part of the rods through the tube first, push the ring hard against the side of the tube, and then secure the rod by tightening the nut on the clamp.

**40.** To fit the dipole, first remove the spacers and the screw in one end of the loop. Slide the rod without the moulding through the main tube and clamp in position. Replace the spacers and screw.

**Note . . .**

*The dipoles must be mounted in the tubes so that when the aerials are on the vehicle, the moulded plugs face inwards with the recessed pin above the protruding pin on one aerial assembly and below on the other. It does not matter which aerial is on the left and which is on the right but if these conditions are not met no IFF signals will be received in the direct-ahead position.*

**41.** Fit the completed aerial assemblies as shown in fig. 35 with the polythene plugs of the dipole pointing inwards. The lug on the main tubes should mate with the hole in the clamp plate of the front support tie-beam. Tighten the wing nuts on the clamping blocks.

**Jacking system**

**42.** A system of screw jacks enables the chassis to be levelled. It is not intended that the jacks shall be used to lift the chassis from the ground but that they shall take the weight of the rotating cabin and ensure

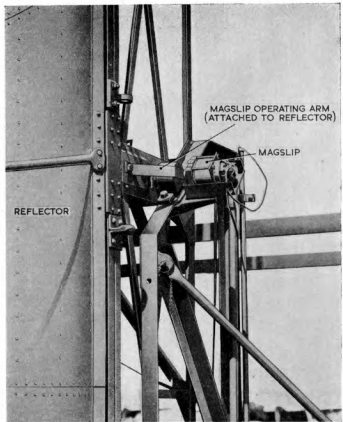

**Fig. 34. R.V.461C : magslip assembly**

that the turntable is level. The system is the same for radio vehicles Type 461C and 462C. The jack handles are stored in two boxes attached to the rear jack arms.

**43.** Fig. 21 shows the sequence of operations and fig. 22 shows the jack arm and jacking board in position. Proceed as follows :—

- (1) Pull the lever up and through 180 deg. to release the jack arm.
- (2) Withdraw the arm about one foot.
- (3) Fit a crank handle to the jack and unwind until the jack will swing into a vertical position.
- (4) Place a base plate at a distance of 3 ft. from the vehicle in line with the jack arm.
- (5) Withdraw the jack arm to its full extent and lower.

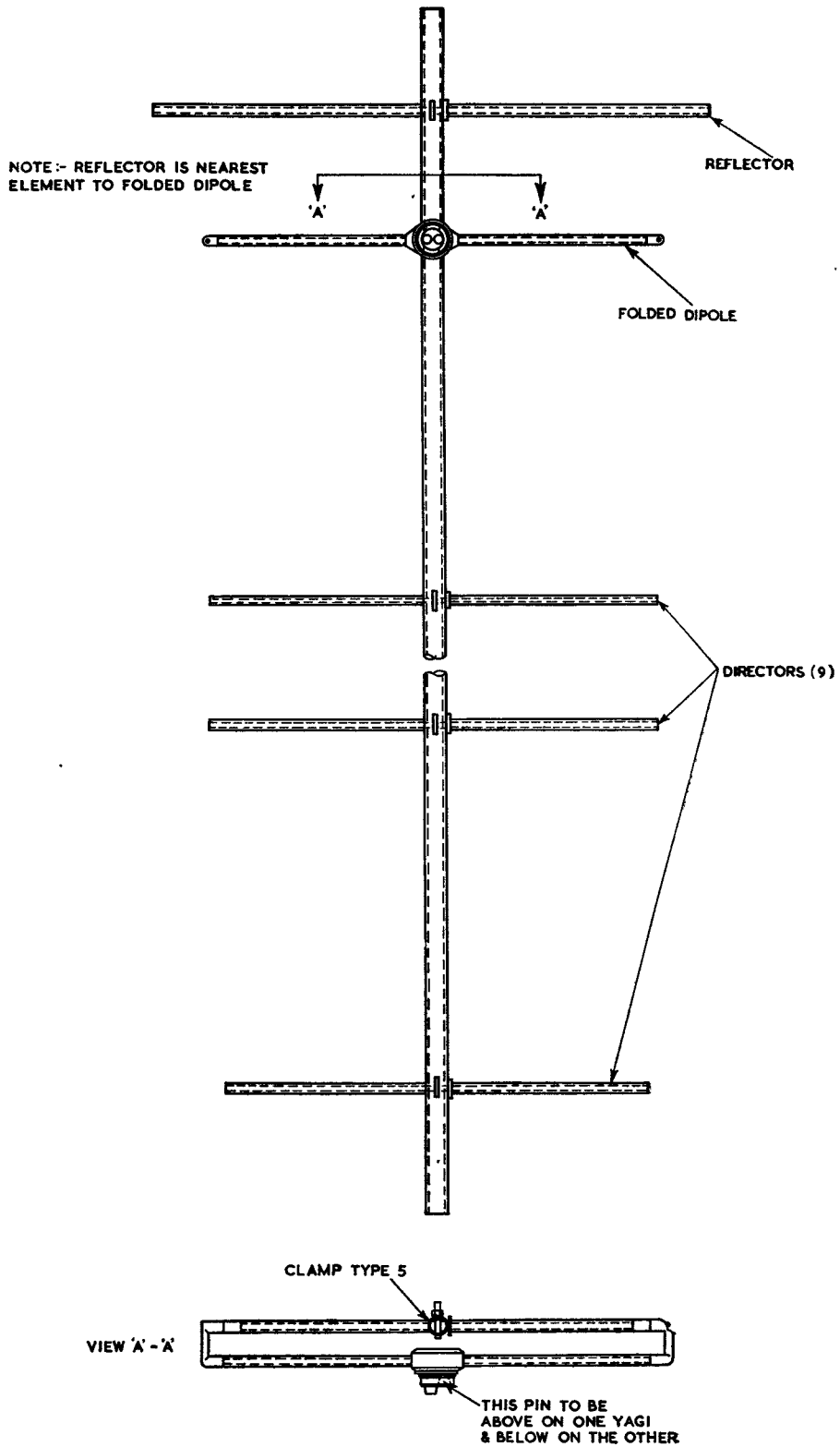

Fig. 35. Aerial array Type 102

- (6) Fit the base plate and lock the jack arm in position by turning the lever back to its original position.
- (7) Screw up the jack until the weight of the cabin is taken up.
- (8) Remove the crank handle, fit a ratchet handle and rotate the jack spindle two turns.
- (9) Repeat (1) to (8) for the remaining three jacks.
- (10) Rotate the cabin by hand and observe the spirit-level behind the selsyn motor on the turning column inside the container.
- (11) Note the azimuths at which the spirit-level indicates a slope and correct by adjusting the appropriate jacks.

#### Removal of cab (fig. 15)

44. Proceed as follows :—

- (1) Roll the top cab cover to the windscreen.
- (2) Fold the windscreen forward with the cover underneath.
- (3) Detach and roll back the cab cover.
- (4) Release the back of the cab and cover frame by undoing 9 bolts.
- (5) Remove the steering wheel by undoing the nut at the top of the steering column and lifting the wheel.

- (6) Place the gear lever in the position where it is furthest towards the front of the vehicle.
- (7) Fold the driving mirror against the bonnet.
- (8) Hook both doors open, fit the cover, and lash down as shown in fig. 15.

#### Internal installation

##### Switchboard (fig. 23)

45. On the right of the voltage regulator box below the AC SUPPLY SWITCH is a plate bearing instructions to be followed when different types of regulator are fitted. The regulator used in AMES Type 21 Mk. 5 will probably be of pattern W.4917, in which case remove the plate to the right of the regulator by removing four screws. Check that a lead is connected to the terminal marked COM and replace the plate. Remove the cover over the terminal box on the regulator and check that the terminal marked COM is connected. Open the regulator door and check that a link marked A-B shorts the COM terminals; close the door and replace the terminal box cover.

46. If a regulator of pattern W.1698 is fitted there is no link in the regulator and the connection between the COM terminals on each terminal strip is omitted.

## INSTALLATION OF RADIO VEHICLE TYPE 467E

#### General

47. Fig. 36 and 37 show radio vehicle Type 467E with radio vehicle Type 181B attached. Radio vehicle Type 467E is a universal operations vehicle designed to house display unit Type 5 and ancillary equipment; radio vehicle Type 181B contains refrigeration plant for the operations vehicle. Display unit Type 5 (in AMES Type 21, Mk. 5) consists of one console Type 15A, one console Type 16, and one console Type 16C. Other items in the vehicle are :—

- (1) 3 plotting tables.
- (2) GPO telephone equipment and associated battery charging apparatus.
- (3) Control units Type 442 and 443.
- (4) Vehicle battery charging apparatus for engine starting and emergency lighting.
- (5) Air conditioning equipment.

48. Fig. 38 and 39 show the layout of these units when the installation is complete. The vehicle body, or container, is thermally insulated and waterproofed to a height of two feet from the floor. Because of this no holes must be drilled in the floor. Two doors are provided; the main entry is at the front near-side of the container but there is also an escape door, with quick-release catch at the rear.

#### Display units

49. For ease of reference the consoles are numbered; when installed, console No. 3 is facing, and consoles No. 2 and 1 are to the right, when entering the main door. When in transit, consoles No. 1 and 2 are secured close to the centre of the floor and console No. 3 is secured against the off-side container wall in its normal operating position (fig. 38). When installing, the first task is to

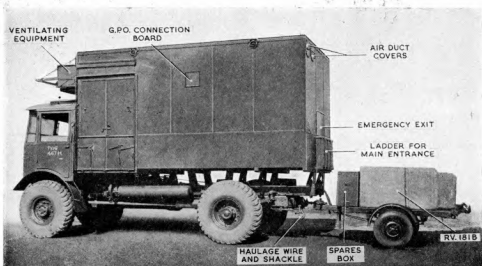

Fig. 36. R.V.467E with R.V.181B on tow

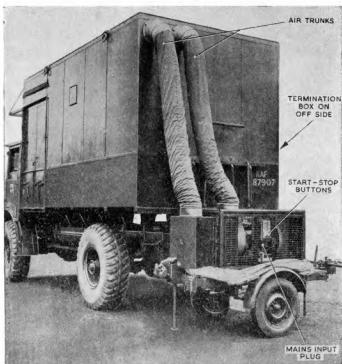

Fig. 37. R.V.467E with R.V.181B in working position

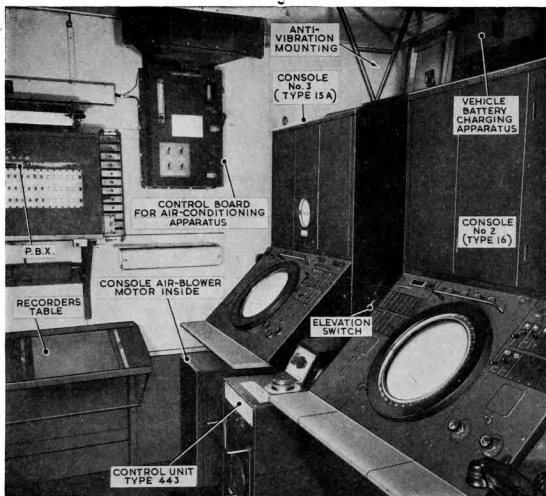

Fig. 38. R.V.467E : view towards front wall

push consoles No. 1 and 2 into their operating positions as follows :—

- (1) Swing the anti-vibration mountings away and clip them to the roof (fig. 38).
- (2) Remove the two bolts securing the consoles to the supporting runners.
- (3) Push the console as far as possible towards the wall.
- (4) The holes in the framework of the console (from which the bolts were removed in (2)) should now line up with two holes in the fixed runners. Replace and tighten the bolts.
- (5) Unscrew the bolts in the section of the runners which is not in use, remove the runners, and store.
- (6) Check that the air duct is making good contact at the rear of the console.
- (7) Repeat (1) to (6) for the remaining console.

**50.** The above procedure must be reversed when preparing the vehicle for transit. Great care must be taken to ensure that all the panels of the consoles are locked in position and the doors closed.

#### Internal cabling

**51.** Radio vehicle Type 467E may be used in a variety of radar stations and the internal wiring is arranged so that only a small amount of installing is necessary for any

particular application. The general system of installation is described in para. 52-54 and the detailed cabling for AMES Type 21 Mk. 5 in para. 55-68.

**52.** External cables are connected to plugs and sockets mounted in a termination box at the off-side rear of the vehicle. The connecting of these cables is described in para. 4-9.

**53.** Co-axial cables (Uniradio 1) lead from the inside of the termination box to the three consoles and to a platform at the side of console No. 1 (fig. 40). In the case of the consoles, the cables are inserted in plugs on the bottom panels; those at the side of console No. 1 are for insertion in the impedance matching junction box.

**54.** Short leads, with "tail" terminations designed to fit into Jones sockets, are wired to the remaining plugs and sockets in the termination box with the exception of plugs No. 29, 30, 31 and 33. The leads from plugs No. 29, 31 and 33 are taken to the distribution board and also to the rear of Jones socket T, S and R respectively. The leads from plug No. 30 are taken to the rear of Jones socket Z. The group of wires from each plug or socket is clamped to the floor and identified by the plug or socket number. The "tails" on the short leads are intended for insertion in Jones sockets which are mounted in a row in the vehicle termination box; the sockets are lettered for reference and the "tails" must be plugged in according to a schedule specially prepared for each application of the radio vehicle. The Jones sockets are connected by cables to correspondingly lettered sockets on the fronts of the consoles. Thus, by adjusting the position of the "tails" in the sockets, any incoming service can be routed to the correct pin on the console termination panel. A further set of leads having tails at both

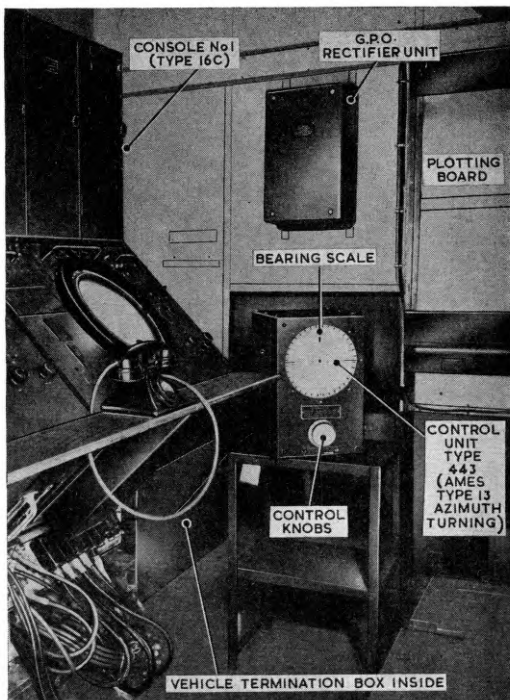
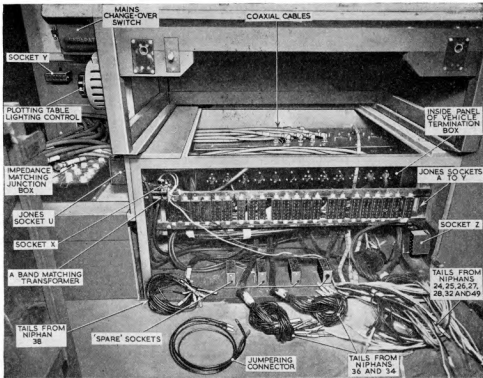

Fig. 39. R.V.467E : view towards rear wall

ends enable services from one console to be routed to another or for common services (for example, 230V supplies) to be distributed.

#### Cabling schedule for AMES Type 21 Mk. 5

**55.** Before commencing the cabling, switch on the interior lights. If the diesel has been started (para. 14) this may be done by turning the switch labelled 230V LIGHTS at the right of the main door. If lights are required before the power vehicles have been put into operation, a 12V emergency system can be used; this supply is obtained from the vehicle batteries and is operated by a switch labelled 12V LIGHTS, also to the right of the main door. A 12V inspection lamp can be plugged into a 2-pin socket beside the rearmost roof light.



**Fig. 40. Termination box**

*Vehicle termination box*

**56.** Verify that the following cables are connected to the Pye plugs on the inside of the vehicle termination box. All the plugs will be connected, but only those listed below are of importance in AMES Type 21 Mk. 5.

Socket No.	Colour.	Service	Destination
1 (ext. right)	Yellow/red	IF input	Imp. matching JB position 5
2 (2nd right)	Yellow/blue	Lock input	
43 (top ext. rgt.)	Green/red	IFF A-band video	Console No. 3; P10 on panel 510
44 (top 2nd. rgt.)	Green/blue	IFF A-band lock	Console No. 3; P14 on panel 510
3	Yellow/green	IF input	Imp. matching JB position 3
6	Yellow/yellow	Lock input	

*Impedance matching junction box*

**57.** Place the impedance matching junction box on the raised platform to the right of console No. 1 (fig. 40) and connect the following cables :—

Colour	JB plug No.	Service	Destination
Yellow/red	5	IF input (Type 14)	Vehicle term. box
Red/white	51	IF out (Type 14)	Console No. 1 ; P1 on panel 520
Blue/white	52	IF out (Type 14)	Console No. 2 ; P1 on panel 520
Yellow/blue	2	Lock input (Type 14)	Vehicle term. box
Red/black	21	Lock out (Type 14)	Console No. 1 ; P3 on panel 520
Blue/black	22	Lock out (Type 14)	Console No. 2 ; P3 on panel 520
Green/slate	23	Lock out (Type 14)	Console No. 3 ; P13 on panel 510
Yellow/green	3	IF input (Type 13)	Vehicle term. box
Green/white	31	IF out (Type 13)	Console No. 3 ; P1 on panel 510
Yellow/yellow	6	Lock input (Type 13)	Vehicle term. box
Green/black	61	Lock out (Type 13)	Console No. 3 ; P3 on panel 510

**58.** Using connectors Type 3001, which consist of short lengths of Uniradio 1 with Pye sockets at each end, connect together plugs 53 and 56, and 32 and 34, on the junction box.

**Console No. 1**

**59.** Connect the following cables to the bottom panel (panel Type 520) of console No. 1.

Colour	Plug No.	Service	Destination
Red/white	P1	IF input (Type 14)	Imp. matching JB position 51
Red/black	P3	Lock input (Type 14)	Imp. matching JB position 21
Red/green/yellow	P2	Strobe pulse	Console No. 3 ; P2 on panel 510
Red/green/white	P8	Calibration markers	Console No. 3 ; P15 on panel 510
Red/green/black	P9	Video signals (Type 14)	Console No. 3 ; P12 on panel 510

**60.** Connect Jones sockets A, D and E, to their respective plugs on panel Type 520. Jones sockets B and C are not connected until the aerials are aligned in azimuth (*Chap. 3, para. 151 and 159*). The Jones socket lettering is from left to right.

**Console No. 2**

**61.** Connect the following cables to the bottom panel (panel Type 520) of console No. 2.

Colour	Plug No.	Service	Destination
Blue/white	P1	IF input (Type 14)	Imp. matching JB position 52
Blue/black	P3	Lock input (Type 14)	Imp. matching JB position 22

**62.** Connect Jones sockets A, D and E to their respective plugs on panel Type 520. Sockets B and C are left until the aerials are aligned.

## Console No. 3

**63.** Connect the following cables to the bottom panel (panel Type 510) of console No. 3.

Colour	Plug No.	Service	Destination
Green/slate	P13	Lock input (Type 14)	Imp. matching JB position 23
Green/red/yellow	P2	Strobe pulse	Console No. 1 ; P2 on panel 520
Green/red/white	P15	Calibration markers	Console No. 1 ; P8 on panel 520
Green/red/black	P12	Video signals (Type 14)	Console No. 1 ; P9 on panel 520
Green/red	P10	IFF A-band video	Vehicle term. box position 43
Green/blue	P14	Lock to A-band IFF transmitter	Vehicle term. box position 44
Green/brown	P6	Magslip input	Vehicle term. box position 12
Green/mauve	P7	Magslip output	Vehicle term. box position 13
Green/white	P1	IF input (Type 13)	Imp. matching JB position 31
Green/black	P3	Lock input (Type 13)	Imp. matching JB position 61

**64.** Connect Jones sockets A, B, C, D and E to their corresponding plugs on panel Type 510.

*ones socket jumpering*

**65.** The wiring from the Niphan plugs and sockets on the inside of the vehicle termination box consists of short leads with coloured tails. By plugging the tails into the appropriate Jones sockets the desired services can be routed to the consoles ; this process is known as "jumpering". Each group of leads is cleated to the floor and identified by the corresponding Niphan plug or socket number.

**66.** This paragraph gives details of the "jumpering" necessary for AMES Type 21 Mk. 5. When making a connection, first locate the bunch of cables bearing the number in the first column ; next identify the tail bound by tape of the colour given in the second column. Insert this tail in the Jones socket lettered and numbered as detailed in the third and fourth columns ; the positions of all the Jones plugs and sockets in the vehicle are shown in fig. 42 of Chap. 4. Tails which are to be inserted in a spare socket must be plugged into one of the Jones sockets marked SPARE ; it is most important that these leads are not left lying about.

Cable Group No.	Colour Code	Jones socket Letter	No.	Service
26	Red	W	3	Master switch for height-finder elevation drive motor
	Blue	W	1	
	Yellow	W	2	
	White	W	4	
	Black	U	3	Control selsyn stator coils R.V.461C (height-finder)
	Slate	U	5	
	Red/blue	U	7	
36	Red	Spare		
	Blue	Spare		
	Green	Spare		

Cable Group No.	Colour Code	Jones socket Letter	No.	Service
36	Yellow	T	1	} 230V supply to repeater selsyn motor in R.V.462C (PPI)
	White	T	2	
	Black	B	3	} Repeater selsyn stator coils in R.V.462C (PPI)
	Black	G	3	
	Slate	B	2	
	Slate	G	2	
	Red/blue	B	1	
	Red/blue	G	1	
	Red/green	B	6	} Azimuth indication switch in R.V.462C (PPI)
	Red/green	G	6	
Red/yellow	B	7	50V DC for AZ. IND. switch	
Red/yellow	Spare			
34	Red	C	1	} Repeater selsyn stator coils in R.V.461C
	Red	H	1	
	Blue	C	2	
	Blue	H	2	
	Green	C	3	} Line of light information
	Green	H	3	
	Yellow	R	1	} 230V supply to repeater selsyn motor in R.V.461C
	White	R	2	
	Black	L	10	Elevation strobe when Mod. No. 405/1 has been carried out
	Slate	Spare		
	Red/blue	Spare		
	Red/green	B	8	} AZ. IND. switch in R.V.461C
	Red/green	G	8	
Red/yellow	G	9	50V DC for AZ. IND. switch	
Red/yellow	Spare			
38	Red	Y	1	} Not used in AMES Type 21 Mk. 5
	Blue	Y	2	
	Green	Y	3	
	Green	T	3	
	Yellow	T	4	
	White	Spare		
	Black	V	3	} Control selsyn stator coils in R.V.462C (PPI)
	Slate	V	5	
	Red/blue	V	7	
27	Red	E	12	Earth
	Blue	D	1	IFF G-band gain
	Green	D	6	IFF G-band remote switching
	Yellow	Spare		
	White	Spare		
	Black	E	5	IFF G-band video
	Slate	Spare		

67. Two wires with tails coloured blue/green and blue/yellow will be found inside the vehicle termination box. The leads disappear into the cable form and are connected to the blower motor contactor circuit associated with the console blower system. Plug the blue/green tail into Jones socket L3 and the blue/yellow tail into L11. The blower system will now be controlled by the thermostat in console No. 3; if it is desired to use the thermostat in console No. 2 plug the leads into F3 and F11 respectively; if it is desired to use the thermostat in console No. 1 plug them into A3 and A11 respectively.

68. The wiring from the termination box is now complete. All the leads which are not being used should be stowed away neatly inside the box. A further "jumping" operation is necessary to route certain common services (for example mains supplies) to the consoles. For this purpose a set of leads (connectors Type 2802) having tails at each end are provided; all these leads are coloured black. Using these leads make the following links:—

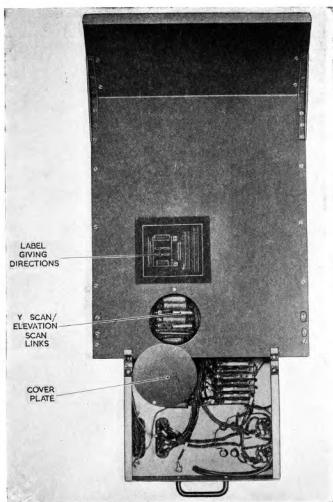

Fig. 41. Elevation scan links on console No. 3

From socket Letter No.	To socket Letter No.	Service
R 3	C 4	230V AC regulated supply (Circuit 1)
R 4	C 5	
R 5	H 4	
R 6	H 5	
S 1	A 7	230V AC unregulated supply (Circuit 2)
S 2	A 8	
S 3	F 7	
S 4	F 8	
S 5	L 7	
S 6	L 8	

From socket Letter No.	To socket Letter No.	Service
T 5	B 4	230V AC regulated supply (Circuit 3)
T 6	B 5	
T 7	G 4	
T 8	G 5	
D 2	P 1	+ 300V strobe control
D 3	P 3	
P 2	P 5	IFF A-band on/off key

**Fitting of control unit Type 442**

**69.** This unit, which is used to control the rotation of the height-finder aerial, is normally operated from the console No. 1 position. Fig. 38 shows the control unit in position and connected to Jones socket U beside console No. 1.

**Fitting of control unit Type 443**

**70.** This unit, which is used to control the rotation of the plan-position aerial, is normally operated from the console No. 2 position. Fig. 39 shows the control unit installed; its cable is connected to Jones socket V which is the right-hand of the two sockets between consoles No. 2 and 3.

**Fitting of elevation switch (fig. 38)**

**71.** This switch is attached to console No. 3; it overrides the switch in R.V.461C which sets the tilting mechanism in operation. The cable is connected to Jones socket W which is the left-hand of the two sockets between consoles No. 2 and 3.

**G.P.O. battery charging apparatus (fig. 39)**

**72.** On initial installation check that the mains tapplings are set for 230V operation.

**Vehicle battery charging apparatus (fig. 38)**

**73.** On initial operation check that the mains tapplings are set for 230V operation.

**Elevation scan links on console No. 3 (fig. 41)**

**74.** Remove one of the two screws securing the circular plate underneath the chassis of indicating unit Type 114. Slide the plate to expose the scan links; for elevation scan working (as in AMES Type 21 Mk. 5) the links must be placed between the centre and left-hand clips.

**Power units Type 377 and 451**

**75.** Lower the right-hand control desk to expose the power unit (fig. 42). Behind the front panel can be seen two terminals marked 4kV and 5.5kV respectively. Check that the tapping is connected to the 5.5kV terminal and change if necessary.

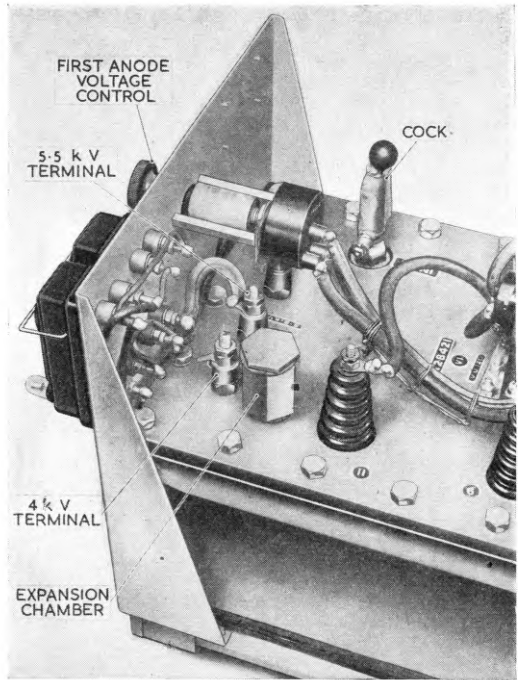

Fig. 42. Power units Type 377 and 451

**76.** There are two cocks on the oil-immersed transformer. These should be closed (horizontal) in transit but open (vertical) in operation. Check the oil level by carefully inserting a piece of clean copper wire in the stop cock opening. The level should be  $2\frac{3}{8}$  in.  $\pm$   $\frac{1}{16}$  in. from the top of the cock. If the level is too low, the power unit should be replaced; excess oil can be drained off by use of the expansion chamber which is sealed by gaskets and two hexagonal nuts.

**Installation of radio vehicle Type 181B**

**77.** When radio vehicle Type 181B is supplied it is attached as a trailer to radio vehicle Type 467E. The installation work consists only of erecting the trailer supporting legs and fitting the trunking (fig. 37) and mains supply cable. Full details are given in a booklet supplied with the vehicle.

## Chapter 3

# SETTING-UP

### LIST OF CONTENTS

	Para.		Para.		
<b>RADAR TRANSMITTER, RECEIVER AND MONITOR</b>		<b>Transmitter Type T.3117</b> . . . . . 65			
<i>Preliminary adjustments</i>		<i>Transmitter setting-up</i> . . . . . 66			
Modulator . . . . .	1	<i>Setting-up mixer unit Type 13</i> . . . . . 70			
Monitor Type 53 . . . . .	3	<i>Initial setting-up</i> . . . . . 71			
Transmitter compartment . . . . .	4	<i>Daily setting-up</i> . . . . . 73			
Transmitter . . . . .	5	<i>Tuning the receivers Type R.3118A</i> . . . . . 74			
Soft rhumbatrons . . . . .	6	<i>Switch unit Type 271 tuning</i> . . . . . 75			
Receiving unit Type 177 . . . . .	7	<b>SETTING-UP IN THE OPERATIONS</b>			
<i>Running up and tuning</i>		<b>VEHICLE</b>			
Switchboard and starter panel . . . . .	8	General . . . . .	76		
Modulator . . . . .	9	Unregulated mains (circuit 2) . . . . .	77		
Switching off the equipment . . . . .	17	Regulated mains (circuit 3) . . . . .	78		
To remove a magnetron . . . . .	18	Regulated mains (circuit 1) . . . . .	79		
To fit a magnetron . . . . .	19	Switching on the consoles . . . . .	80		
To run up a new magnetron . . . . .	20	Switching on the aerial turning control units			
Tuning the transmitter-receiver . . . . .	22	Control unit Type 442 . . . . .	81		
Receiver tuning (using permanent echoes)	26	Control unit Type 443 . . . . .	82		
Soft rhumbatron tuning . . . . .	31	Switching on the elevation tilting motor . . . . .	83		
Monitoring unit Type 56 adjustments . . . . .	32	Plotting tables . . . . .	84		
Range calibration . . . . .	33	Air-conditioning equipment . . . . .	85		
Final tuning . . . . .	35	Ventilation . . . . .	87		
Waveguide piston tuning . . . . .	36	Ventilation and heating . . . . .	88		
Final tuning adjustments . . . . .	39	Refrigerator plant . . . . .	90		
Reversal of waveguide section . . . . .	45	Console blower system . . . . .	92		
<b>SETTING-UP THE AERIAL SYSTEMS</b>		<i>Consoles 1 and 2</i>			
Compensation for aerial squint error . . . . .	46	General . . . . .	96		
Plan-position equipment . . . . .	49	To fit a cathode-ray tube . . . . .	99		
Height-finder equipment . . . . .	50	To insert the CRT . . . . .	100		
Operation of the aerial tilting mechanism . . . . .	51	To adjust the coil rotating mechanism . . . . .	101		
To set up the magslip (R.V.461C) . . . . .	53	To remove the CRT . . . . .	102		
<b>SETTING-UP IFF Mk. 3G IN R.V.462C</b>		To change the PPI window . . . . .	103		
Transmitter Type T.3638 . . . . .	54	Setting-up consoles 1 and 2 . . . . .	104		
Preliminary adjustment . . . . .	55	Preliminary adjustments . . . . .	105		
Transmitter setting-up . . . . .	56	To adjust the focus coil . . . . .	106		
Transmitter frequency and output adjustments . . . . .	57	Timebase synchronization . . . . .	107		
Receiver Type R.3118B . . . . .	58	To adjust the trace . . . . .	110		
Amplifier Type A.3175 . . . . .	59	Range calibration . . . . .	111		
Switch unit Type 271 . . . . .	61	Limiter adjustment . . . . .	113		
Daily transmitter check . . . . .	62	Limiter adjustment (using oscilloscope Type 10)	115		
<b>SETTING-UP IFF Mk. 3A IN R.V.461C</b>		G-band IFF facilities on console 1 . . . . .	118		
General . . . . .	63	Narrow bandwidth unit . . . . .	119		
Mains supply . . . . .	64	IF gain control . . . . .	120		
		To set up the line of light . . . . .	121		

## LIST OF CONTENTS—contd.

	Para.		Para.
Console 3		<b>OPERATION OF THE PLAN-POSITION AZIMUTH TURNING GEAR</b>	
General	124	Running up	145
Preliminary adjustments	125	Operations vehicle	146
To set up indicating unit Type 114	126	Aerial vehicle	147
Focus and first anode tapping points	127	Control of aerial rotation	
Timebase adjustment	130	Hand laying	148
Video signal chain	132	Continuous rotation	149
Narrow bandwidth unit	133	Sweeping a selected arc	150
Console 3 : IFF facilities	134	Adjustment of the PPI trace azimuth	151
Indicating unit Type 123	135	<b>OPERATION OF THE HEIGHT-FINDER AZIMUTH TURNING GEAR</b>	
Timebase unit Type 42	138	Running up	154
Final adjustments—radar	141	Operations vehicle	155
Final adjustments—IFF	142	Aerial vehicle	156
Elevation scan display	143	Control of rotation	
Elevation strobing facilities	144	Continuous rotation	157
		Hand control	158
		Adjustment of line of light azimuth (azimuth of AMES Type 13)	159

## LIST OF ILLUSTRATIONS

	Fig.		Fig.
Modulator	1	R.V.467: distribution board	24
Transmitter compartment	2	R.V.467E: view towards front wall	25
Output unit S.E.2	3	R.V.467E: view towards rear wall	26
Switchboard	4	Panel Type 520	27
Starter panel	5	Console No. 1 (Type 16C)	28
Wavemonitor Type G.86: V5 trigger grid waveform	6	Console No. 2 (Type 16)	29
Wavemonitor Type G.86: V9 (modulator) grid waveform	7	Indicating unit Type 115: interior	30
Wavemonitor Type G.86: magnetron current waveform	8	Indicating unit Type 115: interior	31
Wavemonitor Type G.86: waveforms B, D and F	9	Indicating unit Type 115: interior	32
Monitor Type 53: front panel	10	Power unit Type 379	33
Monitoring unit Type 56: interior	11	IF unit Type 34A: interior	34
Amplifying unit Type 221: interior	12	Follower unit Type 4: assembly of coil rotating mechanism	35
Waveguide piston setting	13	Follower unit Type 4: front view	36
Elevation gearbox	14	Follower unit Type 4: optical system	37
Transmitter Type T.3638: front panel	15	Console No. 3 (Type 15A)	38
Transmitter Type T.3638: interior	16	Power unit Type 451: interior	39
G-band IFF receiving equipment in R.V.462C	17	Power units Type 377 and 451: tag boards	40
IFF Mk. 3A: general view in R.V.461C	18	Timebase unit Type 42: sync. link panel	41
Transmitter Type T.3117: front panel	19	indicating unit Type 123: focus and first anode tapping points	42
Transmitter Type T.3117: interior	20	Indicating unit Type 123: links A and B and focus control tappings	43
Calibration chart for transmitter Type T.3117	21	Timebase unit Type 42: divider control waveforms	44
Mixer unit Type 13: front panel	22	Indicating unit Type 123: radar trace	45
Mixer unit Type 13: interior	23	Starter unit Type 13 (R.V.462C)	46
		Control unit Type 443: front panel	47

## RADAR TRANSMITTER, RECEIVER AND MONITOR

### PRELIMINARY ADJUSTMENTS

#### Modulator (fig. 1)

1. Check that the cables at the rear of the unit are securely connected. Set the pulse width switch below the voltmeter to LONG PULSE.

2. Remove the right-hand upper panel. At the rear will be seen the two arms of a spark gap. One arm, which is attached to the framework is adjustable; set it until the gap is one inch wide. Replace the panel.

#### Monitor Type 53 (fig. 1)

3. Set the local oscillator tuning control to the middle of its range, i.e., approximately five turns from either extreme. Check that

all cables are secure and that all plugs are occupied except STROBE, VID. SIG. and CHECK CAL.

#### Transmitter compartment (fig. 2)

4. A wrist watch should not be worn when working near the magnet.

#### Transmitter

5. Proceed to adjust the transmitter as follows:—

- (1) Remove the right-hand side and front panels of the compartment.
- (2) Turn the capstan (1) clockwise (as viewed from the front) until the magnetron probe projects as far as

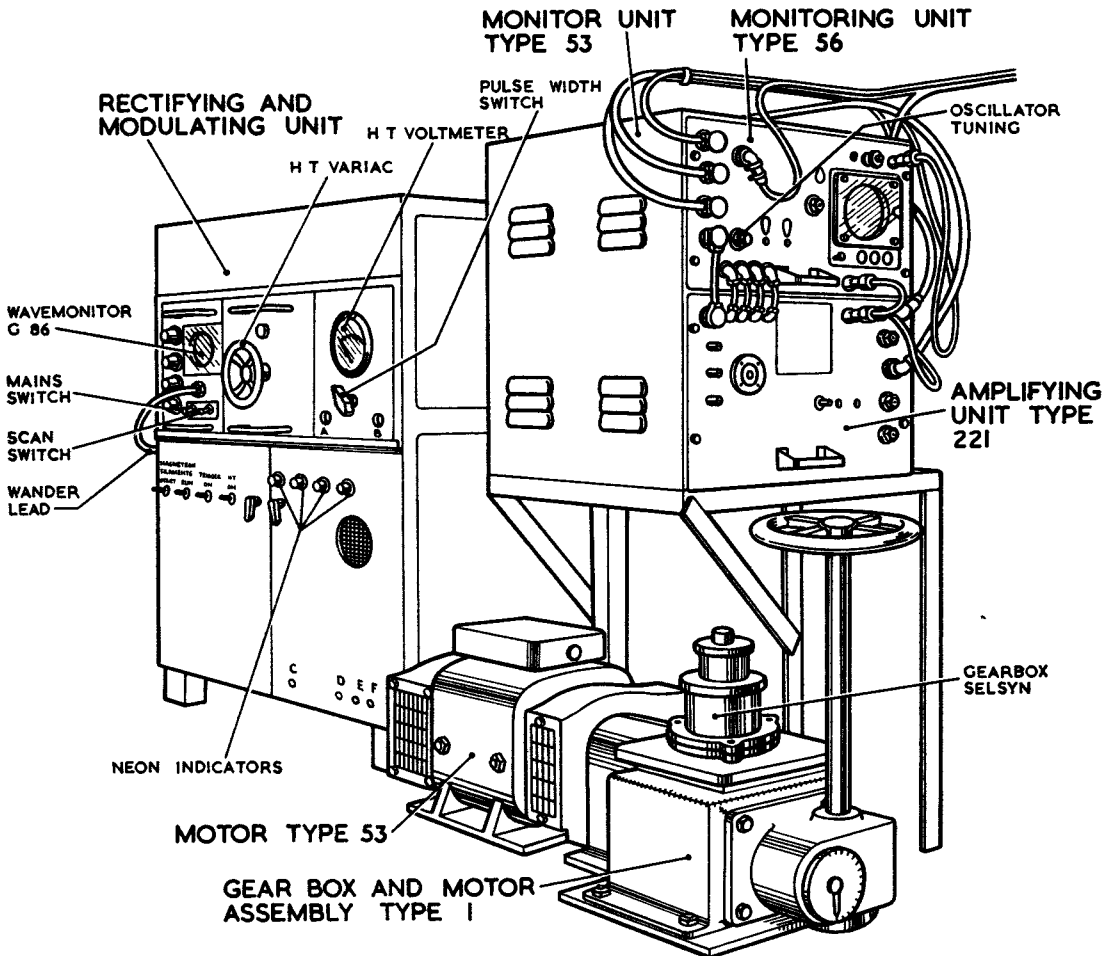
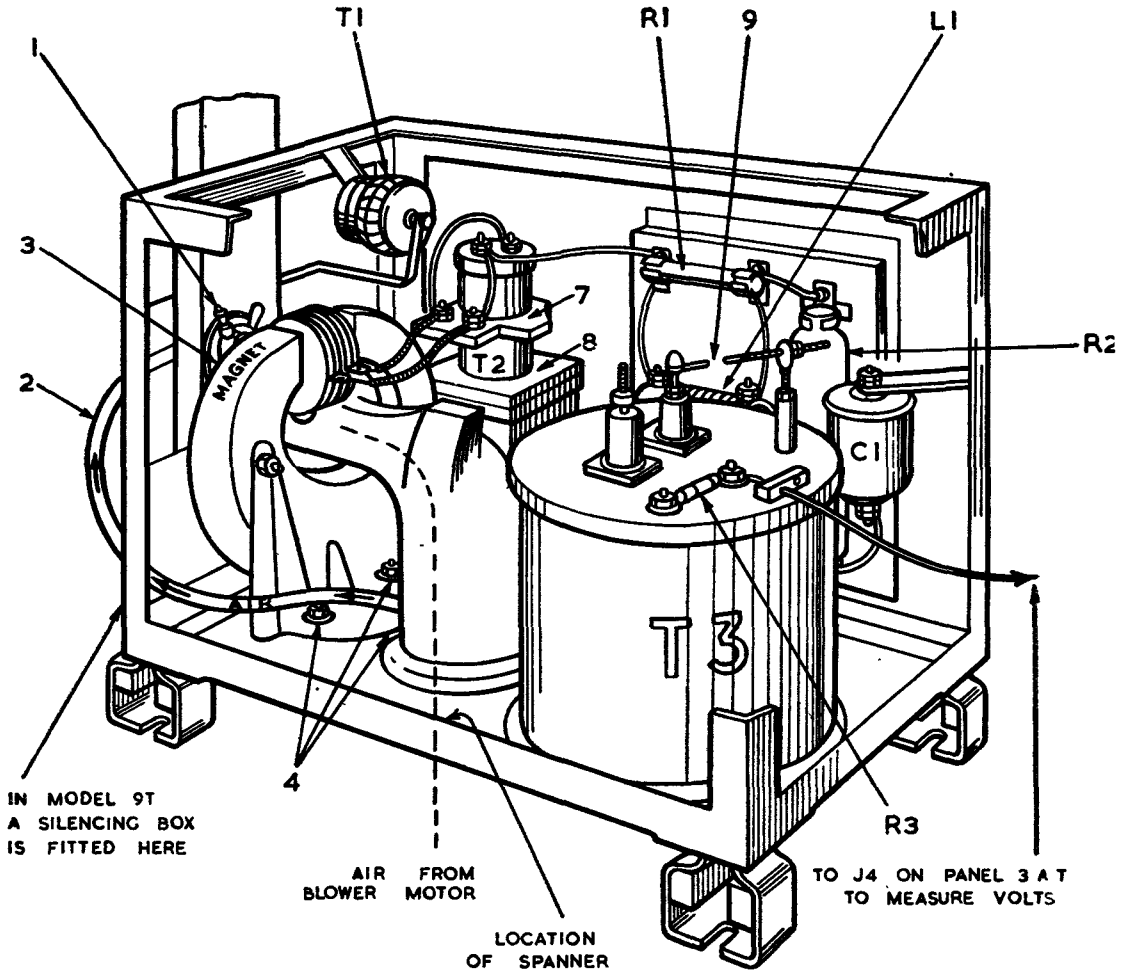

Fig. 1. Modulator



IN MODEL 9T  
A SILENCING BOX  
IS FITTED HERE

AIR FROM  
BLOWER  
MOTOR

LOCATION  
OF SPANNER

TO J4 ON PANEL 3 AT  
TO MEASURE VOLTS

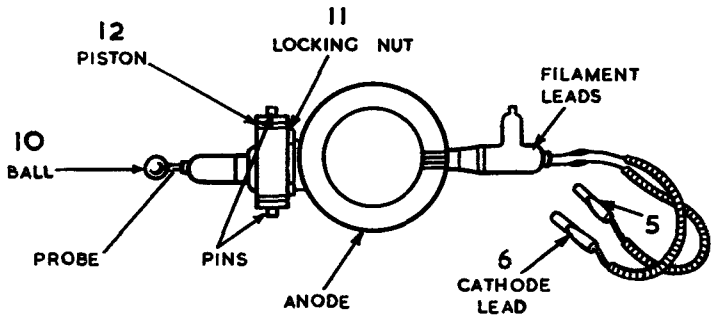

**MAGNETRON TYPE CV 76**

**Fig. 2. Transmitter compartment**

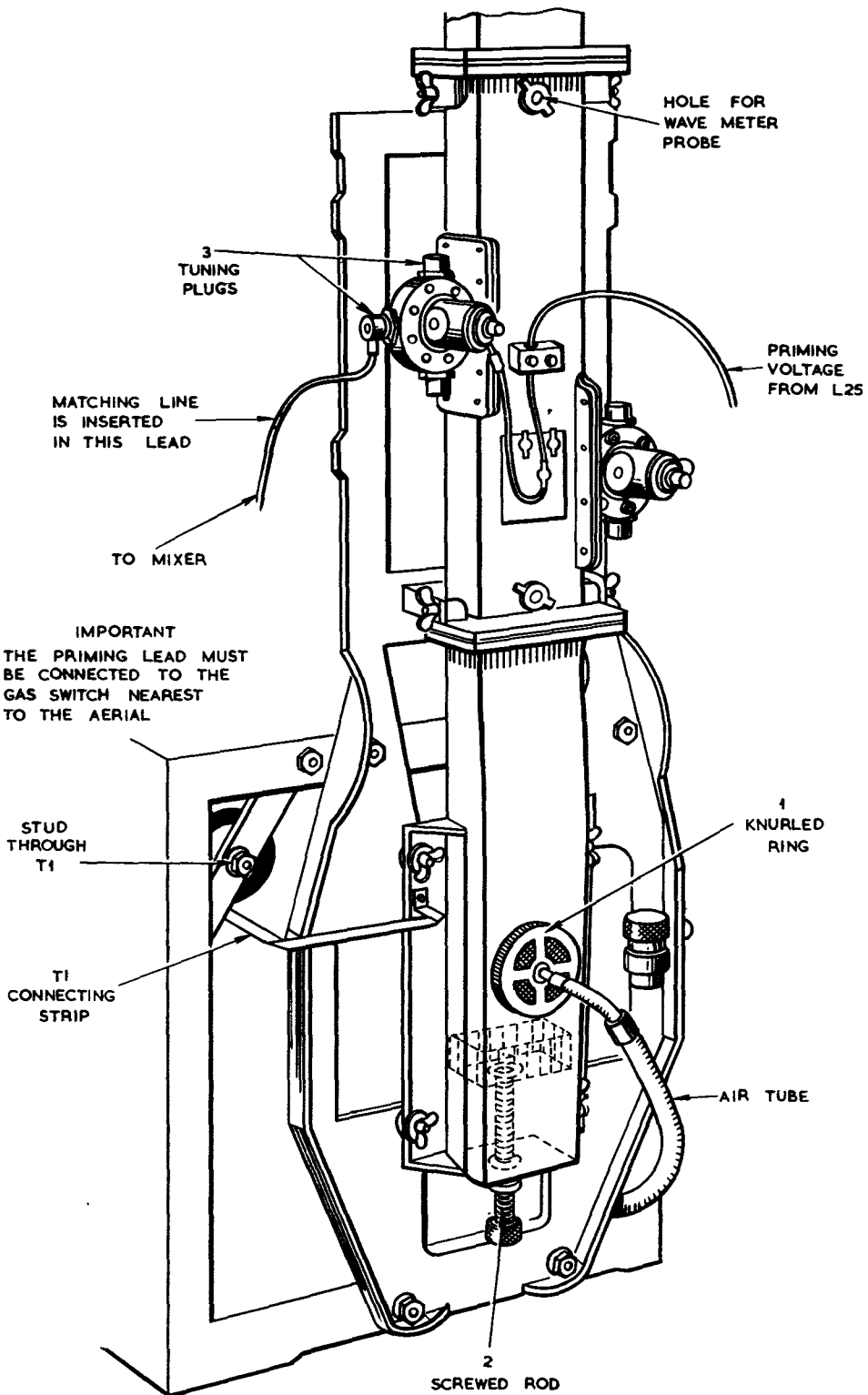

Fig. 3. Output unit S.E.2

possible into the waveguide. The probe can be seen by removing the air-pipe (2) and unscrewing the inspection cover (fig. 3, item 1).

- (3) Check that the magnetron lies centrally between the pole faces of the magnet (3) without touching either. Slacken the three bolts (4) securing the magnet and adjust its position if necessary.
- (4) Check that the magnetron filament leads (5 and 6) are not taut; they should be separated from each other and clear of the air cowling. If the leads are taut, lower the collar (7) on the filament transformer (8).
- (5) Check that the magnetron filament transformer primary leads are connected to the correct terminals. The terminals are 0 and 2.
- (6) Adjust the spark gap (9) on top of T3 at the rear of the compartment, to one inch. The rearmost arm is variable.
- (7) Set the waveguide matching piston (fig. 3, item 2) to its mid-position.

#### Soft rhumbatrons (fig. 3)

6. These should be adjusted as follows:—

- (1) Remove the metal cover by releasing the four screws to give access to the upper and lower rhumbatrons (valves Type CV193).
- (2) Each valve has tuning slugs (3) embodied in the resonator section which is secured to the waveguide. These should all be set to a mid-way position, i.e., approximately 5 turns out.
- (3) A lead connects the upper CV193 to receiving unit Type 177 via a matching device which contains two adjustable sliding slugs; set each slug to the mid point of its travel.
- (4) Interposed between the matching device and the resonator section of the CV193 is an adjustable coupling loop; rotation of the coupling loop alters the amount of pick-up. Screw the coupling loop in

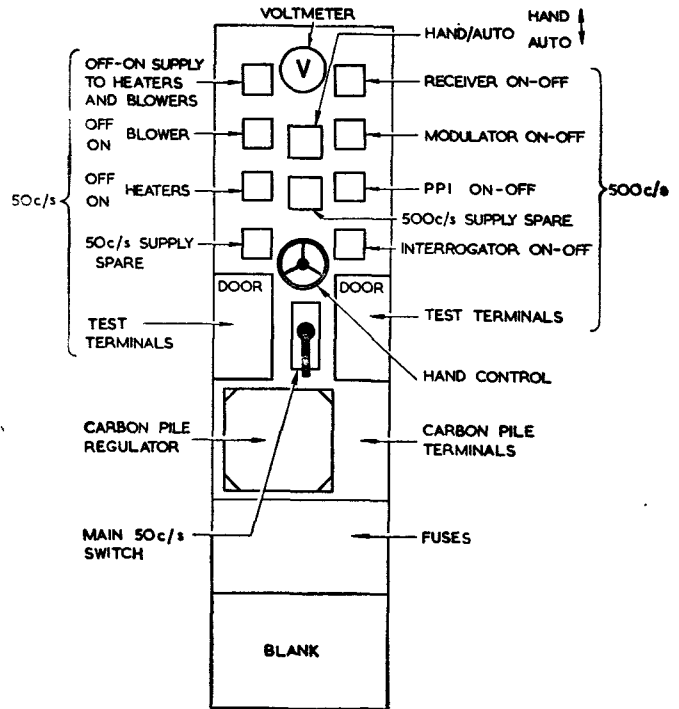

Fig. 4. Switchboard

as far as possible and then set it so that the retaining clip attached to it is 30 deg. from the vertical. Pick-up is maximum when the clip is vertical.

#### Receiving unit Type 177

7. Perform the following operations on the receiving unit.

- (1) Remove the cover.
- (2) Push the probe from the matching device as far into the mixer chamber as possible and then withdraw it one tenth of an inch.
- (3) Push the probe from the local oscillator as far into the mixer as possible and then withdraw it one tenth of an inch.
- (4) Turn the mixer tuning screw so that it is half-way in (approximately 5 turns from either extreme).

#### RUNNING UP AND TUNING

##### Switchboard and starter panel (fig. 4 and 5)

8. The controls on the switch board and starter panel should be set as follows:—

- (1) Switch on the 50 c/s AC SUPPLY switch.
- (2) Set the HAND-AUTO switch to AUTO.

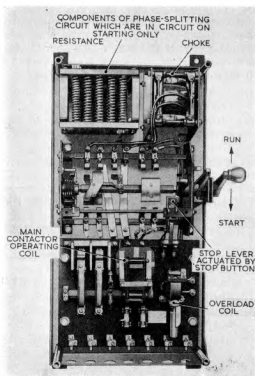

Fig. 5. Starter panel

- (3) Hold down the handle at the right-hand side of the starter panel (fig. 5). If it will not go down, press the red button to release the handle. When the motor reaches full speed (after 30 sec. to one minute) push the handle smartly upward into the RUN position. The voltmeter (fig. 4) should now read 180V; if it is high or low, adjust the voltage regulator by means of the control on its front panel. Automatic regulation should normally be employed, but in the event of failure, use hand regulation as follows:—

- Set the HAND-AUTO switch to HAND.
- Turn the regulator control hand wheel fully counter-clockwise. Now start the motor and then, by means of the hand wheel, adjust the voltage to 180V. The change from HAND to AUTO can be made at any time without switching off any equipment, but the hand wheel must first be turned fully counter-clockwise.

- (4) Switch on the following:—
- |                                |        |
|--------------------------------|--------|
| (a) HEATERS AND BLOWERS        | } 230V |
| (b) BLOWERS                    |        |
| (c) HEATERS                    |        |
| (d) SPARE (for alternator fan) |        |
| (e) RECEIVER                   | } 180V |
| (f) MODULATOR                  |        |

#### Modulator (fig. 1)

9. Check that the modulator lower doors are shut so that the interlock switches are made. Verify that the neon indicators (except the one at the extreme left) are glowing. The one on the extreme right should glow intermittently as the thermostat operates.

10. Close the magnetron filament START switch and then, after 30 seconds:—

- Close the filament RUN switch.
- Close the TRIGGER switch.

11. Close the MAINS SUPPLY switch on wave monitor Type G86, and set the scan switch to ELLIPTICAL; then:—

- Adjust FOCUS and BRILLIANCE controls as necessary.
- Adjust the HORIZONTAL SHIFT and VERTICAL SHIFT controls until the elliptical trace is centrally disposed on the tube. If the timebase is absent or unstable, adjust the sync. control through the hole in the front panel. Turn it fully counter-clockwise then clockwise slowly, until a steady trace occupies about two thirds of the width of the screen.

12. A wander lead with a jack plug at its end is attached to the wave monitor. Plug the jack into socket C at the bottom left of

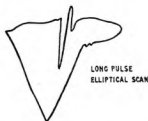

1 VOLT ON TRIGGER GRID SHOWN BY DEFLECTION EQUAL TO 1 VOLT ON Y PLATES OF CRT. SENSITIVITY ROUGHLY EQUAL TO 62 VOLTS PER CENTIMETRE

Fig. 6. Wavemonitor Type G.86: V5 trigger grid waveform

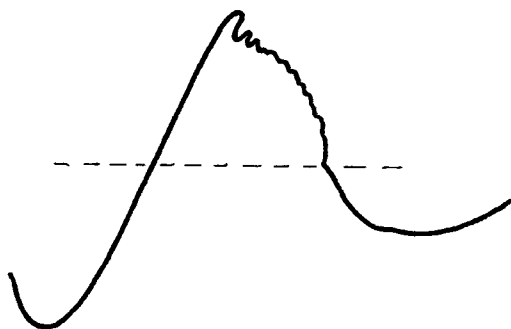

VOLT ON CRT = 1 VOLT ON MODULATOR GRID

Fig. 7. Wavemonitor Type G.86 : V9  
(modulator) grid waveform

the right-hand door. The waveform displayed on the monitor tube should be similar to that illustrated in fig. 6. Check the sync. control setting if the waveform appears to be incorrect.

13. Set the scan switch to FAST, and plug the jack into monitor socket E which is the centre of three sockets at the bottom of the right-hand door. Fig. 7 illustrates the waveform to be expected.

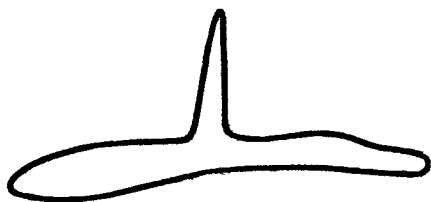

1 VOLT ON CRT = .44 AMP MAGNETRON CURRENT

Fig. 8. Wavemonitor Type G.86 : magnetron  
current waveform

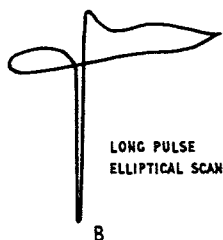

1 VOLT ON CRT = 13 KV MAGNETRON

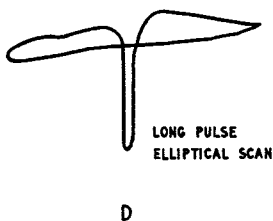

1 VOLT ON CRT = .9AMP MODULATOR CATHODE

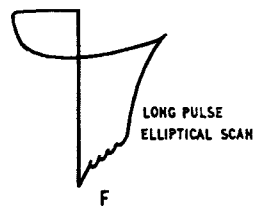

1 VOLT ON CRT = .07 KV MODULATOR ANODE

Fig. 9. Wavemonitor Type G.86 : waveforms B, D and F

14. Before proceeding with the next step, make sure that at least 15 minutes have elapsed since the magnetron filament was switched on. If the magnetron should be a new one, this period must be extended to 30 minutes. Now proceed as follows:—

- (1) Turn the HT Variac fully counter-clockwise.
- (2) Close the HT switch; the neon at the extreme end of the group should now glow.
- (3) Turn the HT Variac control slowly clockwise until the voltmeter reads 5kV. Inspect the wave monitor trace (jack E). A split at the top of the waveform (fig. 7) indicates that the magnetron is not yet ready to take full HT; the CV12 modulator valve may also glow brightly if this is the case, and the Variac should be turned fully counter-clockwise and the HT switched off for a few minutes longer.
- (4) Monitor the waveform at socket A below the voltmeter (fig. 8).
- (5) Turn up the Variac until the meter reads 8kV. Switch off the magnetron filament START and RUN switches.
- (6) Turn the Variac control fully clockwise slowly, and verify that the thermostat is still working.

15. Measure the transmitter wavelength using wavemeter Type G82A which is mounted on the partition facing the monitor receiver. (Instructions for the use of this instrument will be found in *Chap. 4, para. 64*).

Make a note of the transmitter wavelength.

16. Check the waveforms at monitoring points B, D and F. The results should be similar to those illustrated in fig. 9. Re-adjust the voltage regulator output reading to 180V (*para. 8 (3)*).

**Switching off the equipment**

**17.** Turn the Variac control slowly counter-clockwise to the limit of its travel ; then :—

- (1) Turn off all the switches on the modulator left-hand door starting from the right.
- (2) Turn off all the switches on the switch-board except the HAND-AUTO and AC SUPPLY switches. The 180V and 230V supplies to the monitor and modulator chassis may, of course, be switched off as desired by operating the appropriate switch on the switchboard without switching off the entire equipment.
- (3) Stop the alternator by pressing the red button on the starter panel.
- (4) Switch off 50 c/s AC SUPPLY.

**To remove a magnetron (fig. 2)**

**18.** Remove the nearer section of the right-hand side of the magnetron compartment and withdraw the special box spanner attached to the inside of it ; then proceed as follows :—

- (1) Slacken four knurled nuts holding the top half of the air cowling, and detach it.
- (2) Disconnect the magnetron filament leads (5 and 6).
- (3) Turn the capstan until the small pin, which is held in place by a spring, can be removed from its hole.
- (4) Continue to turn the capstan counter-clockwise until the magnetron recedes as far as possible.
- (5) Slacken the nuts which clamp the magnet to the base and slide the magnet back as far as it will go.
- (6) Gently ease the magnetron out of the magnet gap taking care not to knock the ball (10) against the edge of the capstan hole.
- (7) Unscrew the ball and pull it off the probe.
- (8) Slacken the locking nut (11) and unscrew the piston (12) from the magnetron. A spanner is provided for releasing the lock-nut, and it is normally attached to the base chassis behind the magnet.
- (9) Place the magnetron in its wooden holder.

**To fit a magnetron (fig. 2)**

**19.** Remove the magnetron from its wooden holder. Then :—

- (1) Place the ball (10) on the output probe. The sleeve in the ball is split for adjustment. If it fits too loosely on the probe, screw in the sleeve slightly ; if too tightly, screw the sleeve out.
- (2) Screw on the locking nut as far as possible.
- (3) Hold the magnetron with the fins vertical. Screw on the piston (12) as far as possible then back slightly until the pins are vertical and in line with the centre of the magnetron fins.
- (4) Lock the nut back on the piston with the spanner provided.
- (5) Hold the magnetron in the right hand with the fins vertical and the glass pip of the filament lead uppermost and insert it gently into the hole in the capstan. Turn the capstan with the left hand until the magnetron is drawn towards the waveguide.
- (6) Lift the spring (13) and turn the capstan until the pin engages the hole in the capstan body. This is to prevent the magnetron from becoming detached from the waveguide.
- (7) Screw the capstan clockwise as far as it will go, then back a quarter turn.
- (8) If the centre of the magnetron body does not lie evenly between the pole faces of the magnet, the position of the pole faces must be adjusted. Move the magnet as far forward as possible, taking care that the sides of the magnetron are not touching, and retighten the lock-nuts.
- (9) Connect the filament leads (5 and 6). The lead which is identified by a pip in the glass and has a thick pin must be connected to the rearmost terminal.
- (10) Replace the air cowling and tighten the nuts which secure it.
- (11) Check that the filament leads are not touching the cowling.

**To run up a new magnetron**

**20.** The process known as hardening, which is described here, must be performed on initial installation of the station, and subsequently whenever a new magnetron is fitted.

It will be found advantageous to harden all spare magnetrons as convenient to save time in the event of magnetron failure. This is the method :—

- (1) Ensure that the tappings on the filament transformer are connected to the correct terminals (*para. 5(5)*).
- (2) Run up the transmitter as far as switching on the HT.
- (3) Turn up the HT Variac until the meter reads 3·5kV. Monitor the waveform at socket A.
- (4) Turn up the HT at a rate of 1kV per ten minutes. In the event of arcing in the transmitter, turn back the HT a little and then up more slowly.

**21.** When once a valve has been hardened, it should be put into service for 2 to 3 days every three months since a valve which is left out of service for a considerable time tends to become soft again.

## WARNING

*If the HT has been applied to the set but for some reason the modulator valve has not fired, the discharge line condensers will retain their charge. They can be discharged by connecting a lead to earth and then to the pulse switch contacts.*

### Tuning the transmitter-receiver

**22.** During the following operations, a close watch must be kept on the mixer crystal current. It has been found that the mixer works most efficiently when the current through the crystal is in the order of 500 to 600 micro-amperes. A 500 micro-ampere meter is plugged into a socket adjacent to a jack socket marked TO METER on amplifying unit Type 221 (*fig. 10*). A wander lead with a jack plug on either end is plugged into the TO METER socket and is used to connect it to the CRYSTAL TEST jack socket which is in series with the crystal mixer on the side of receiving unit Type 177. The mixer crystal current is then indicated on the meter.

**23.** A factor exerting considerable influence on the amount of crystal current is the degree of coupling in the local oscillator ; provision is therefore made for adjusting the coupling.

**24.** Immediately above the local oscillator tuning knob on monitoring unit Type 56 is

a plug from which the output of the local oscillator is taken (*fig. 10*). The plug may be rotated and is locked by means of a collar and screw. A pin indicates the position of the pick-up loop which projects into the klystron cavity. Pick-up is a minimum when the pin is vertical.

**25.** Initially, the pin should be 30 deg. from the vertical, but it should always be adjusted after a tuning operation. When instructions read "tune for maximum crystal current", decrease the coupling first so that the meter reads less than 500 micro-amperes ; then tune for maximum crystal current. Finally, increase the coupling until the meter reads 500 micro-amperes. It is important to ensure that the output lead is firmly fastened to the Pye plug, otherwise loss of signal may result. This provision applies to all signal leads.

### Receiver tuning (using permanent echoes)

**26.** The receiver should already be switched on. Adjust the BRILLIANCE and FOCUS controls under the CRT window (*fig. 10*) until a well focused trace is obtained. Switch to short range by turning the extreme right-hand knob under the CRT window so that the yellow spot is uppermost.

**27.** Insert a screwdriver through the upper of two holes at the left of the CRT and adjust the horizontal shift until the start of the trace lies somewhere near the centre of the CRT screen. This is done to simplify tuning, since it enables the ground ray to be seen while the operator does preliminary tuning operations.

**28.** The transmitter wavelength should have been noted previously (*para. 15*). If it was found to be outside the range of 9·9 to 10·1 cm. it will be necessary to alter the coarse tuning plungers of the local oscillator (*fig. 11*). To do this, the upper and lower chassis of monitor Type 53 should be withdrawn slightly by removing the eight securing bolts. If the transmitter wavelength is greater than 10·1 cm., unscrew both plungers two turns ; if it is less than 9·9 cm. screw them in two turns. If it is found impossible to make two turns when the wavelength is short, unscrew the plungers three turns, thus tuning the local oscillator to a longer wavelength than that of the transmitter.

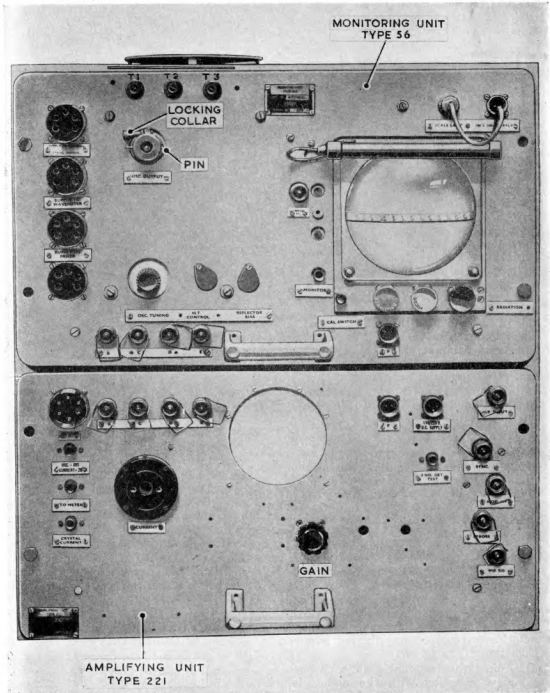

Fig. 10. Monitor Type 53 : front panel

29. Turn the gain control (fig. 10) fully clockwise, then back by a quarter turn. Rotate the aerial until a permanent echo is observed on the monitor trace. In the case of the height finder (R.V.461C), it may be necessary to tilt the aerial by 3 to 4 deg. If no signals appear, the receiving chain will probably be well off tune. Start therefore by observing the ground ray at the start of the trace. Make this as wide as possible by turning the short velocity pre-set knob fully clockwise (fig. 11). Set the local oscillator tuning knob to its mid position and alter one of the local oscillator coarse tuning plungers. The shape of the ground ray will be seen to alter as the plunger is turned, and small signals within the ground ray will pass through their maxima. Tune the second plunger in a similar manner for maximum signal. Next turn the oscillator tuning knob, likewise for maximum signal. Do not forget to adjust the crystal current each time (para. 25).

30. Set the gain control for a quarter inch of noise. A further rotation of the aerial should now enable a suitable permanent echo to be located. Efforts should be made to identify reliable permanent echoes, since a knowledge of the range and bearing at which echoes normally appear greatly simplifies the tuning procedure. When an echo has been located, reduce the gain as much as possible.

#### Soft rhumbatron tuning

31. The soft rhumbatrons (valves Type CV193) are located at each side of the waveguide. Before tuning, remove the protective metal cover by slackening the four screws. Then proceed as follows:—

- (1) Adjust the two tuning slugs on each valve, starting with the upper, for maximum permanent echo amplitude. Check crystal current.
- (2) The output from the upper valve is taken via a matching unit which incorporates two tuning slugs. Adjust each

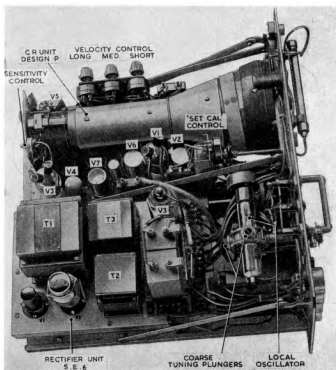

Fig. 11. Monitoring unit Type 56 : interior

for maximum signal; first the top and then the bottom. Check crystal current.

- (3) Adjust the position of the output coupling (para. 25) to give 500 microamperes of crystal current.

Signals should now be obtained, but before the final tuning is attempted, the transmitter and receiver should be left for about an hour to warm up.

#### Monitoring unit Type 56 adjustments

32. The following adjustments to the monitoring unit may be done while the transmitter and receiver are being allowed to settle down.

- (1) Adjust BRILLIANCE and FOCUS controls to give a trace of suitable sharpness and brilliance.
- (2) If the trace is not parallel to the range scale it will be necessary to rotate the CRT slightly to make it so. Estimate the amount by which the CRT needs to be turned and switch off the unit. Withdraw the top chassis completely and slacken the nut in the centre of the CRT base bracket. Turn the CRT by

the desired amount and tighten the nut. Replace the chassis and switch on the unit.

- (3) Push in the CAL SWITCH.
- (4) Adjust vertical shift by inserting a screwdriver into the lower of two holes to the left of the CRT window until the bases of the calibrator pips are three quarters of an inch below the range scale.

#### Range calibration

**33.** Monitoring unit Type 56 (part of monitor Type 53) is used only as a means of adjusting the transmitter and receiver in the AMES Type 21 Mk. 5 installation; it enables the operator to ensure that the best possible results are being obtained before passing the 45 Mc/s IF signals to the operations vehicle. Accurate calibration of the monitor trace is not essential, and it is sufficient to calibrate only on the short range. However, the complete calibration procedure is detailed below in case it should be required.

- (1) Turn the range switch to long (i.e., so that the red spot is uppermost).
- (2) Turn the pre-set long velocity control (fig. 11), which is accessible through a hole in the side of the monitoring unit, fully counter-clockwise.
- (3) Withdraw the chassis as far as possible. The lead to the soft rhumbatron (top left) and the oscillator output lead may be removed to do this. Turn the SET CAL control (fig. 11) until 49 pips appear on the trace. It will be necessary to bring the trace towards the centre of the screen by means of the horizontal shift control in order to count the pips.
- (4) Switch to short range (yellow spot uppermost). Verify that the tumbler switch adjacent to the long velocity pre-set control is up.
- (5) Adjust horizontal shift so that the first pip coincides with zero on the top scale. Adjust short velocity pre-set so that the 7th pip coincides with 6 on the upper scale, and the 13th pip with 12 on the upper scale.

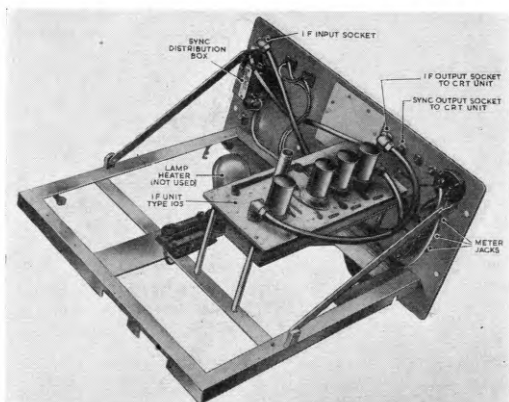

Fig. 12. Amplifying unit Type 221 : interior

- (6) Switch to medium range (blue spot uppermost).
  - (7) Adjust medium velocity pre-set control only, so that
    - (a) The 7th pip coincides with 3 on the upper scale.
    - (b) The 13th pip coincides with 6 on the upper scale.
    - (c) The 25th pip coincides with 12 on the upper scale.
- Note . . .**  
*After calibrating the short range, do not alter the horizontal shift setting.*
- (8) Switch to long range (red spot uppermost).
  - (9) Adjust the long velocity pre-set control so that :—
    - (a) The 25th pip coincides with 6 on the upper scale.
    - (b) The 49th pip coincides with 12 on the upper scale.

**34.** Perfect calibration is extremely difficult to obtain on the long range, but some improvement may result from slight adjustment of the SENSITIVITY control which is affixed to the CRT rear supporting bracket (fig. 11). If this control is moved, the calibration of all three ranges must be repeated. The sensitivity control is normally set at 90 per cent. of its clockwise travel, which gives almost maximum scan amplitude. After adjustment, the SENSITIVITY and SET CAL. controls should be

locked by means of the screw clamps provided.

### Final tuning

**35.** This must not be attempted until the transmitter and receiver have been running for at least an hour. Remember to set the mixer crystal current after each adjustment.

### Waveguide piston tuning

**36.** Unscrew the plunger (*fig. 3, item 2*) until it is fully out; make sure that the locking ring also is fully unscrewed. Measure the distance from the underside of the waveguide to the top of the plunger screw, using the scale provided. Measure the transmitter frequency, using test set Type 288 or test set Type 223A. Calculate the power output with output tester Type 65 (*Chap. 4, para. 26*).

**37.** Screw in the plunger a half-centimetre at a time, and note the frequency and power output at each step. Plot the results and draw smooth curves through the points obtained. The curves should be similar to those in *fig. 13*. The best plunger setting will be that at which maximum power and frequency stability exist (point X in *fig. 13*). Set the plunger to this point and lock it. Adjust the local oscillator.

**38.** Note the transmitter frequency at the optimum plunger setting as it will be required for setting up the aerial systems.

### Final tuning adjustments

**39.** Tune the mixer as follows:—

- (1) Vary the degree of insertion of the signal input probe into the mixer until maximum signal is obtained.
- (2) Adjust the local oscillator input probe in the same manner.
- (3) Adjust the mixer chamber tuning screw for maximum crystal current.

Lock each adjustment by means of the appropriate nuts after tuning.

**40.** Retune the soft rhumbatron tuning slugs. Tune the upper one first then the lower. Finally, re-adjust the upper. Lock the slugs.

**41.** Trim the waveguide plunger for maximum signal, but do not turn more than a half turn in either direction.

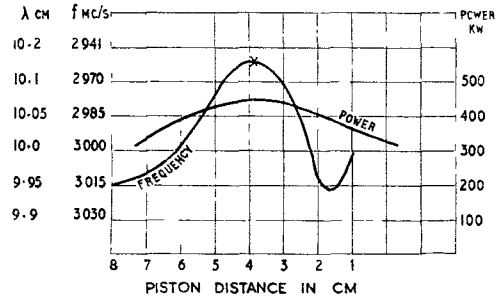

**Fig. 13. Waveguide piston setting**

**42.** Re-adjust the matching slugs (top, bottom, then top again) for maximum signal. Lock the slugs.

**43.** Adjust the position of the soft rhumbatron output coupling for maximum signal. Lock it.

**44.** Turn the pre-set REFLECTOR HT control (*fig. 10*) for maximum crystal current. Turn the pre-set REFLECTOR BIAS control (*fig. 10*) gradually clockwise and note the point at which there is a sudden drop in crystal current. Turn back fully counter-clockwise, and then turn gradually clockwise so that the crystal current becomes a value slightly less than the figure at which the sudden drop occurred. Adjust the magnetron capstan (*para. 5 (2)*) for maximum signal.

### Reversal of waveguide section (*fig. 3*)

**45.** The section of the waveguide which includes the soft rhumbatrons may be reversed in an attempt to improve performance.

- (1) Disconnect the priming lead from the upper valve.
- (2) Unscrew the four nuts securing the waveguide section to the framework. Be careful not to drop any washers or insulating spacers.
- (3) Remove the screw securing the right-angle bracket to the framework.
- (4) Detach the waveguide section carefully; invert and replace it.
- (5) Secure the section to the framework.
- (6) Slacken the four wingnuts and adjust the section so that a gap of  $\frac{1}{16}$  in. is maintained between the section and the waveguide below it. Ensure that the two sections are now in line.
- (7) Replace the right-angle bracket.

## SETTING-UP THE AERIAL SYSTEMS

### Compensation for aerial squint error

**46.** Normally, the radar beam from a centimetric radar aerial is propagated at right angles to the long dimension of the parabolic section of the reflector. However, in AMES Type 21, because of certain design peculiarities, the beams are propagated at an angle less than 90 deg. to the long dimension. The difference is known as squint error, and compensation must be made for it when setting-up the station.

**47.** The compensation for the plan-position equipment merely consists of the subtraction of a few degrees in azimuth when aligning the turntable and PPI traces. The error in the height finder is much more serious and the aerial tilt angle must be adjusted.

**48.** The extent of the squint error is a function of transmitter wavelength and this must be measured accurately, using a test set Type 288 or 223A. The following table gives the squint for various wavelengths.

Wavelength (cm.)	Squint (degrees)
9.8	5.7
9.85	5.4
9.9	5.0
9.95	4.6
10.0	4.3
10.05	4.0
10.1	3.6
10.15	3.3
10.2	2.9

### Plan-position equipment

**49.** Subtract the squint error from any compass bearing in order to obtain the real "angle of shoot."

### Height-finder equipment

**50.** As the beam is required to go out at —1 deg. with the aerial at minimum tilt, 1 deg. must be subtracted from the squint error figure and compensation made for the resultant error. The procedure for taking up the squint error is as follows :—

- (1) Obtain angle of squint from the table.
- (2) Subtract 1 deg. from this figure.
- (3) Tilt the aerial by hand to its minimum tilt position.

- (4) Adjust the length of the connecting rod (*Chap. 2, fig. 33*) until the pointer on the elevation scale (*Chap. 2, fig. 33*) is opposite the figure arrived at in operation (2). One turn of the connecting rod turnbuckle alters the elevation angle by approximately 0.6 deg.

### Operation of the aerial tilting mechanism

**51.** The height finder aerial is mechanically tilted in elevation continuously so that the radar beam sweeps between 1 deg. depression and 20 deg. elevation. One cycle takes 6 seconds. To set the tilting mechanism in motion, it is only necessary to start the driving motor. The switching sequence is :—

- (1) Close the ELEVATION CONTROL switch (R.V.467 distribution board).
- (2) Close the master switch (inside R.V.461C).
- (3) Close the elevation switch (display unit Type 5, console 3).

**52.** Any one of the three switches may be used to stop tilting, but that on the display unit will bring the aerial to rest at a pre-determined angle of elevation which depends on the setting of switch unit Type 1172 attached to the motor shaft. Since the motor cannot stop instantaneously, because of the inertia of the system, it will be necessary to experiment with the switch unit setting until a point is reached so that the aerial stops at the required angle of tilt (usually minimum). Two knurled screws must be slackened in order to adjust the position of the striking area of the switch unit (*fig. 14*). Modification 405/1 may have been done on the equipment. This involves replacement of switch unit Type 1172 by switch unit Type 902 and gives elevation strobe facilities (*para. 11A*).

### To set up the magslip (R.V.461C)

**53.** To preserve linearity, there must always be some coupling between the two magslip coils.

- (1) Observe the output at oscilloscope point V4A in scanning unit Type 14 (console 3).

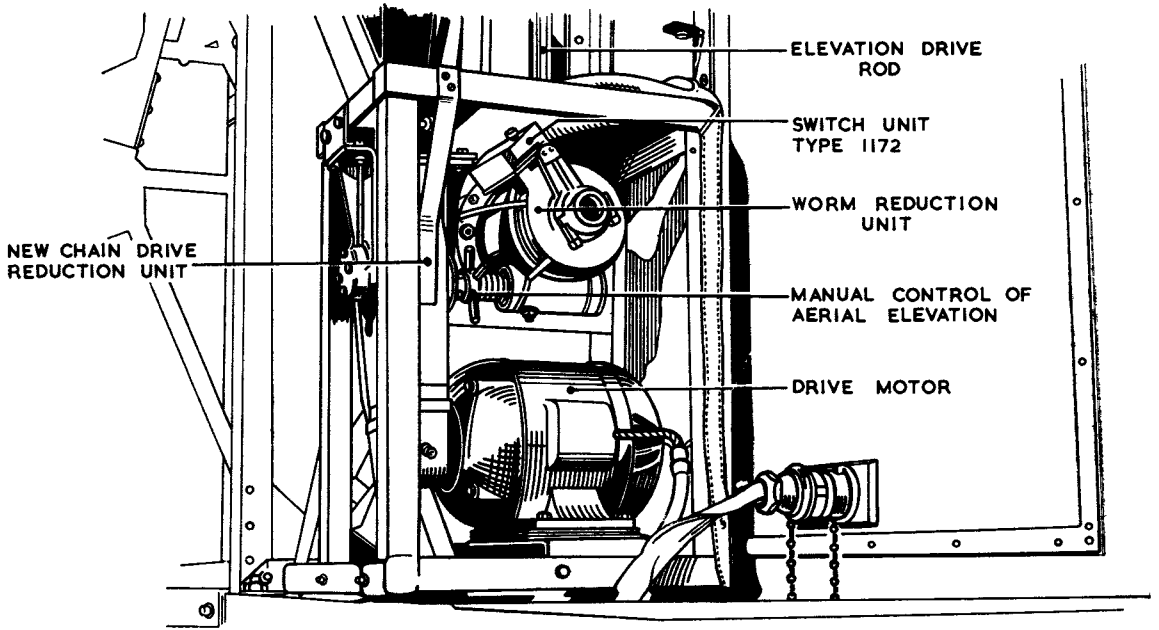

Fig. 14. Elevation gearbox

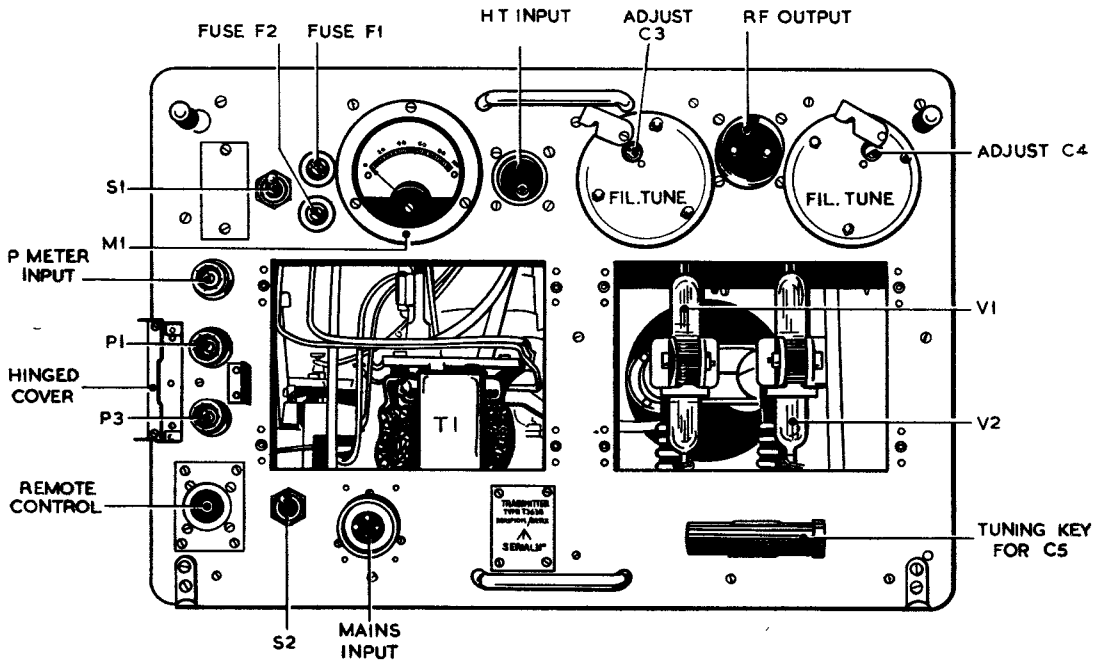

Fig. 15. Transmitter Type T.3638 : front panel

- (2) Set the aerial at minimum tilt. Slacken the clamps and rotate the magslip body until the point of minimum coupling is reached. Mark the position with respect to the brass housing, then rotate the body counter-clockwise by about

one sixth of an inch. Tighten the magslip clamps.

- (3) Check by observing the waveform as the aerial rotates continuously. The amplitude should never fall to zero.

### SETTING-UP IFF Mk. 3G IN R.V.462C

#### Transmitter Type T.3638

54. This transmitter receives its high-voltage supply from the main radar transmitter which must be switched on in order to adjust the IFF transmitter.

#### Preliminary adjustment (fig. 16)

55. The G-band equipment mains supply switch is the right-hand of three switches inside the aerial vehicle above the slip ring unit. Place this switch in the OFF

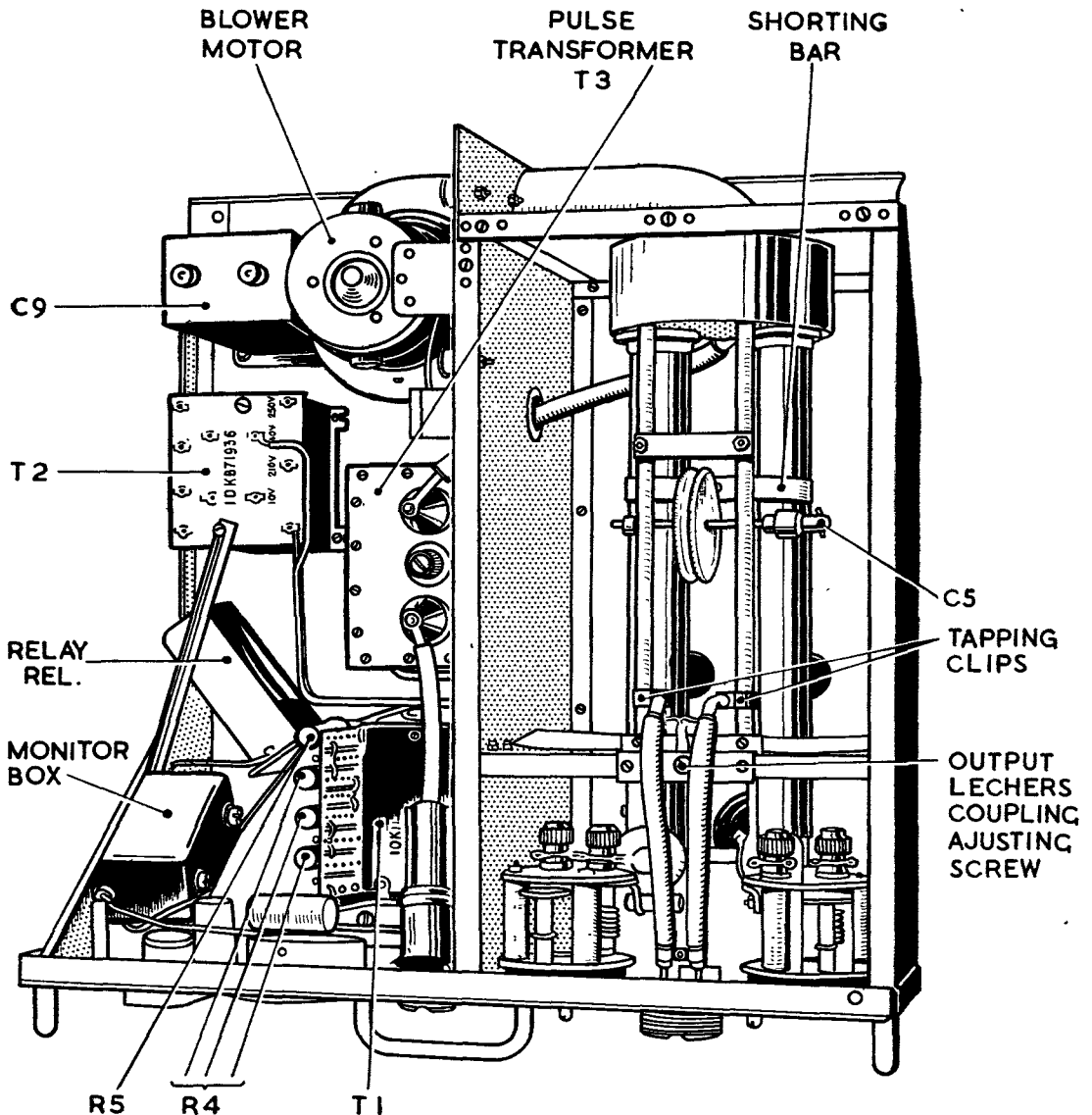

Fig. 16. Transmitter Type T.3638 : interior

position. Remove all connectors to the transmitter and remove its dust cover. Perform the following operations :—

- (1) Verify that the mains input leads are connected to the 0 and 230V tags on transformer T2 at the centre left of the chassis (*fig. 16*).
- (2) Check that the pulse transformer T3 (centre right of the chassis) is out of circuit, and that the HT input is taken to a stand-off insulator on the side of the oscillator compartment.
- (3) Remove the screws securing the lid of the oscillator compartment and slide the anode lechers shorting bar about half way along the lechers.
- (4) Adjust the spacing between the plates of the output lechers tuning condenser (C5) to be about  $\frac{3}{8}$  in. to  $\frac{1}{2}$  in.
- (5) Insert a screwdriver through one of the holes marked FIL TUNE on the front panel (*fig. 15*); turn the control fully counter-clockwise and then back  $1\frac{1}{2}$  turns; do the same with the other control.
- (6) Set the tapping clips on the output lechers (*fig. 16*) so that the edges of the clips nearer the valves are  $\frac{3}{8}$  in. from the output lechers shorting bar.
- (7) Set the output lechers coupling screw (*fig. 16*) about halfway; i.e., about three turns from either extreme.
- (8) Replace the transmitter on the runners without its dust cover. Reconnect the mains and aerial leads.

#### **Transmitter setting-up**

**56.** Turn the MAINS switch to its ON position (*fig. 15*); the blower motor should then be heard and the oscillator valve filaments should light. Now proceed as follows :—

- (1) Switch on and set up a wavemeter Type W.1649 and monitor Type 33 (*Chap. 4, para. 14 and 20*).
- (2) Connect the HT pulse lead and switch on the radar transmitter.
- (3) Switch the LOCAL-REMOTE switch on the front panel of the IFF transmitter to LOCAL. Inspect the spark gaps fitted to the switch unit Type 271: if the transmitter is operating, a spark will be seen across the gaps.
- (4) Use monitor Type 33 to examine the pulse shape. Adjust condensers C3,

C4 and C5 (*fig. 15 and 16*) to give a substantially square pulse envelope of maximum amplitude. The pulse width should be about 2 microseconds; it can be checked with the calibration facilities offered by monitor Type 33.

#### **Note . . .**

*The output lechers tuning condenser C5 may be adjusted by inserting the special Bakelite tool into the hole at the right-hand side of the transmitter.*

#### **Transmitter frequency and output adjustments**

**57.** Check the transmitter frequency with wavemeter Type W.1649. The frequency is unlikely to be within  $\frac{1}{2}$  Mc/s of that required. Note the reading, and switch off the HT from the IFF and radar transmitters. Perform the following operations on transmitter Type T.3638 :—

- (1) Disconnect and withdraw the transmitter; if the measured transmitter frequency was too low, move the anode lechers shorting bar nearer to the valves. If it was too high, move the bar in the other direction (a movement of one sixteenth of an inch alters the frequency by about 1 Mc/s).
- (2) Repeat the transmitter setting-up procedure given in para. 56, and repeat adjustments to the anode lechers shorting bar until the measured frequency falls within  $\frac{1}{2}$  Mc/s of 209 Mc/s.
- (3) Switch off, disconnect and withdraw the transmitter.
- (4) Fit the oscillator compartment lid and dust cover; replace the transmitter.
- (5) Reconnect the leads to the transmitter and switch it on.
- (6) Adjust the filament tuning condensers C3 and C4 until the measured frequency is 209 Mc/s, and adjust the output lechers tuning condenser for maximum output.
- (7) Switch the LOCAL-REMOTE switch to REMOTE; this transfers control of the transmitter to the A ON-OFF-G ON switch on console 1 in the operations vehicle (R.V.467).

#### **Receiver Type R.3118B**

**58.** The tuning of this unit is similar to that of receiver Type R.3118A except that the oscillator in R.3118B is pre-set to 209 Mc/s and consequently does not require adjustment.

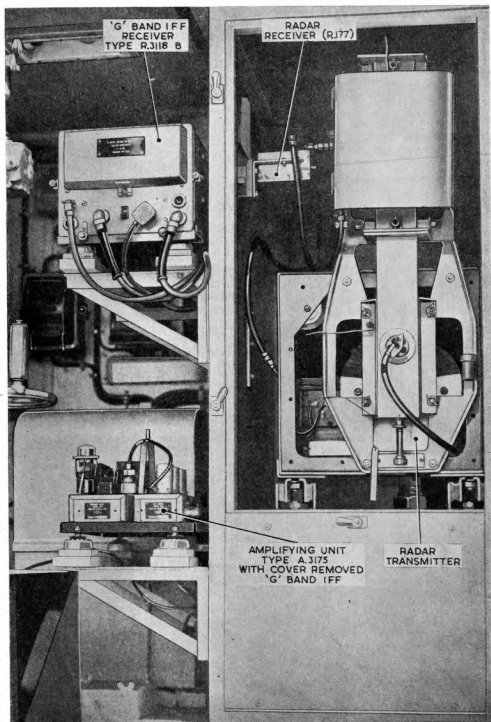

Fig. 17. G-band IFF receiving equipment in R.V.462C

- (1) Feed a signal at the frequency measured in para. 57 into receiver Type R.3118B ; use a signal generator Type 53 (square wave modulated) for this purpose.
- (2) Adjust aerial and RF trimmers to give maximum output as observed on an oscilloscope.

#### **Amplifier Type A.3175**

**59.** Remove the metal cover, and check that the mains input tapplings are correct. These will be seen at the rear left-hand of the power unit section.

**60.** Transfer the input from wavemeter Type W.1649 to the amplifier, and tune the trimmers on the amplifier section for maximum output, using the special tool located at the right-hand side of the unit. There are three trimmers ; one adjacent to each valve.

#### **Switch unit Type 271**

**61.** The switch unit should be roughly

tuned by reference to the calibration chart affixed to it.

- (1) Observe that the spark gaps are firing correctly : there should be a steady bright glow between the electrodes.
- (2) Feed a signal at 209 Mc/s into the switch unit from signal generator Type 53.
- (3) Observe the output from receiver Type R.3118B on an oscilloscope or on monitor Type 33 (*Chap. 4, para. 14*). Adjust the tuning knobs on the switch unit for maximum response. Do not turn the knobs more than one complete turn in either direction.

#### **Daily transmitter check**

**62.** A small pick-up aerial, mounted on the IFF aerial framework, feeds a " P " meter in transmitter Type T.3638. The deflection of the meter gives a day-to-day indication of the transmitter output.

### **SETTING-UP IFF Mk. 3A IN R.V.461C**

#### **General**

**63.** A view of IFF Mk. 3A, in position in the aerial vehicle, is given in fig. 18.

#### **Mains supply**

**64.** The ironclad switch to the left of mixer unit Type 13, controls the supply to all IFF units.

#### **Transmitter Type T.3117**

**65.** Disconnect the transmitter cables, and withdraw it from its case. Check that the mains tapplings (*fig. 20*) are set for 230V and that the link is set to HIGH.

- (1) Connect a voltmeter, by means of a jack plug and suitable lead, into the hole marked FIL 1 VOLTS and check that a reading of 3.45V is obtained. Repeat for FIL 2 VOLTS. If the readings are incorrect, adjust the tapping clips of resistances R2 and R3 (*fig. 20*).
- (2) Set the grid and cathode lechers shorting bars to the positions shown on the graph (*fig. 21*) according to the required operating frequency. The measurements given in the graph refer to the edges of the shorting bars nearer the valve.

- (3) Set the FREQ ADJ control to its mid position.
- (4) Replace the transmitter in its case, taking care to see that it is pushed well back so that the interlock circuit is completed (*fig. 20*). Reconnect the transmitter leads.
- (5) Remove the aerial feeder and connect the artificial aerial instead.
- (6) Switch on the mains supply ; the transmitter is now ready to be set up.

#### **Transmitter setting-up**

**66.** Make the two switches marked FIL CONTROL (one of these is on the transmitter panel and the other on the modulator panel). Green indicator lights will show when the circuits have been completed.

- (1) Wait 30 seconds for the thermal delay switches to operate, and then close the modulator HT CONTROL and transmitter HT CONTROL switches. A red indicator lamp should light for each switch.
- (2) The lamp in the artificial aerial will glow if the transmitter is working. Tune the aerial coupling condenser C1 for maximum brilliance by using a screwdriver through the hole in the top of the transmitter case.

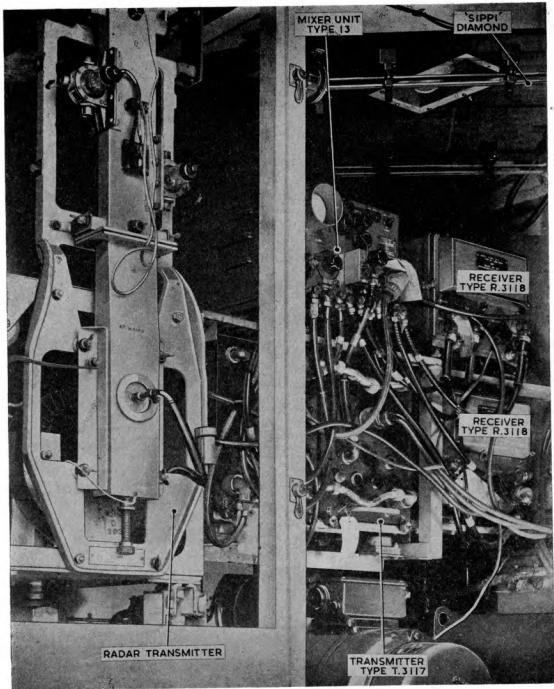

Fig. 18. IFF Mk. 3A : general view in R.V.461C

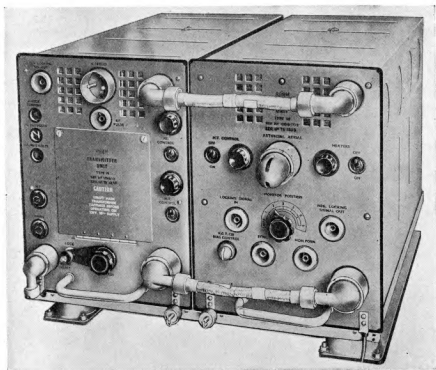

Fig. 19. Transmitter Type T.3117 : front panel

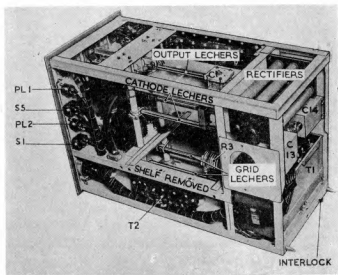

Fig. 20. Transmitter Type T.3117 : interior

- (3) Use the wavemeter in mixer unit Type 13 (*para. 71*) to check the frequency. The probe may be removed from the wavemeter co-axial cable and the free end inserted into the socket marked RF PULSE for this purpose.
- (4) If the frequency is found to be close to the operational frequency, the slight adjustment required may be made on the grid condenser C24. If the measured frequency is far outside the operating frequency, the grid lechers shorting bar will require resetting. Movement of the bar closer to the valve will increase frequency (1 cm. corresponds roughly to 5 Mc/s).

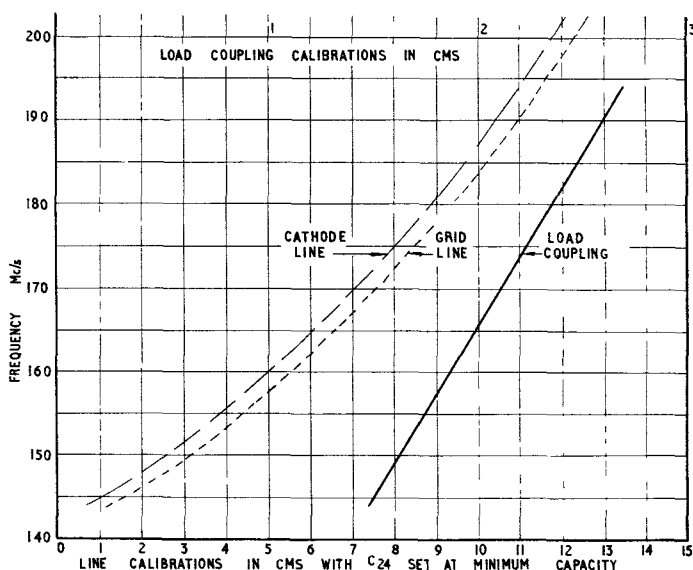

Fig. 21. Calibration chart for transmitter Type T.3117

**67.** Adjust the cathode lechers tapping point for maximum power output as indicated by the brightness of the lamp in the artificial aerial. A recommended method of doing this is to move the tap one centimetre nearer the valves and observe the brilliance of the lamp. If it appears to have increased, a further centimetre move should be made in the same direction and so on until the point of maximum brilliance is found. Do not move the tap about haphazardly, but be methodical about the adjustment. Adjust the aerial coupling condenser after each operation. The position of the cathode lechers tapping point affects the frequency slightly; therefore, when the best tapping point has been found, the frequency should be checked again and correction made by means of the small grid condenser.

**68.** Adjust the aerial tapping point in a manner similar to that adopted for the cathode tapping point (*para. 67*). The position of the aerial tap does not affect the transmitter frequency.

**Note . . .**

*It is important to adjust the aerial coupling condenser C1 after each tuning operation.*

**69.** Check the anode current at the ANODE CURRENT jack on the transmitter. A reading of 0.5mA is average for a pulse repetition frequency of 50 c/s, or 1mA for 100 c/s.

**Setting-up mixer unit Type 13 (fig. 22 and 23)**

**70.** The setting-up of the mixer unit may conveniently be divided into two stages. The first stage is that required on initial installation and consists of setting up the duration, velocity and X-shift of the timebase on the monitor CRT. It is necessary to remove the dust cover in order to get at the controls. The second stage of the setting-up will normally be performed during daily maintenance and can be completed in 5 to 10 minutes without removing the dust cover.

**Initial setting-up**

**71.** Perform the following operations:—

- (1) Remove the dust cover from mixer unit Type 13.
- (2) Close the mains switch to the left of the mixer unit. Switch on the mixer unit, the two receivers Type R.3118A and transmitter Type R.3117. Allow one minute for the equipment to warm up.
- (3) Set the selector switch at D so that the narrow and direct receivers feed into the mixer unit.

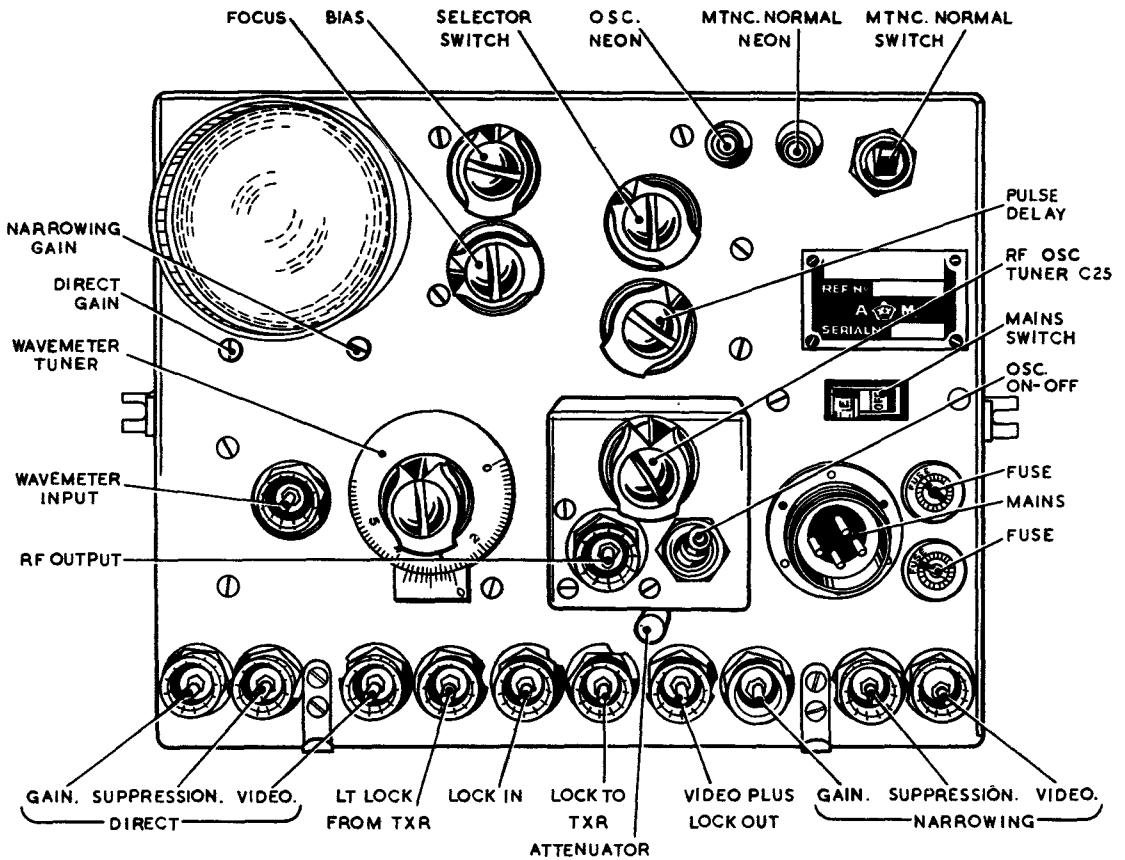

Fig. 22. Mixer unit Type I3 : front panel

- (4) Set the MTNC-NORMAL switch to NORMAL and depress the IFF A-BAND key on display unit Type 5 (console 3). A timebase trace should now be obtained as the unit will lock from the display unit Type 5 display; transmitter Type T.3117 will also lock from the display unit.
- (5) Set the wavemeter control of the mixer unit to the required operating frequency, using the calibration chart provided.

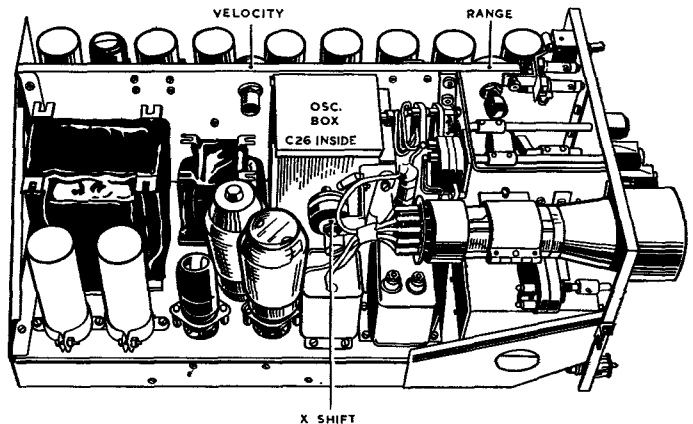

Fig. 23. Mixer unit Type I3 : interior

**72.** It is necessary to adjust the duration of the monitor CRT timebase (and hence the suppression pulse fed to the receivers) so that it is slightly longer in range than the timebase of the display unit Type 5 IFF display.

This ensures that the video signals from the receivers are not suppressed before the end of the IFF timebases on the display unit.

- (1) Switch on the RF oscillator (the warning neon will glow) and push in the

attenuator. Set condenser C25 to its mid-position, and tune the oscillator using C26 (*fig. 23*) so as to obtain an upward-going pulse on the monitor CRT.

- (2) Connect the RF output socket of the mixer unit to the input socket of the direct receiver using the test lead provided.
- (3) Turn the velocity control (inside mixer unit Type 13) to minimum and the range control to maximum (*fig. 23*).
- (4) Adjust the DELAY control on the front panel so that the leading edge of the test pulse is right at the end of the timebase on the display unit Type 5 display (indicating unit Type 123).
- (5) Turn the range control (inside mixer unit Type 13) until the monitor timebase finishes at the trailing edge of the test pulse.
- (6) Adjust the velocity and X-shift controls to give a monitor timebase trace about 4.5cm. long and central on the screen.
- (7) Replace the dust cover and readjust the delay control on the front panel so that the test pulse appears at about the centre of the monitor timebase trace.
- (5) Switch on the pulsed oscillator (the second warning neon should glow) and tune it to the wavemeter using the monitor display. Condenser C26 (*fig. 23*) is the main frequency control. The front panel control is for fine adjustments over a range of 7 Mc/s.
- (6) Connect the RF output socket of the pulsed oscillator to the input of the narrowing receiver with the test lead provided. Set the selector switch to B.
- (7) Adjust the oscillator attenuator to give a pulse of about half saturation on the monitor display. Tune the narrowing receiver (*para. 74*) to the test pulse; if necessary, reduce the RF output by means of the attenuator to prevent the test pulse from saturating the receiver.
- (8) Adjust the NARROWING GAIN so that 1 mm. of noise is seen on the monitor display. It is important that this noise level should not be exceeded. Adjust the attenuator to give a test pulse 1 cm. high. Do not alter this attenuator setting subsequently.
- (9) Connect the RF output of the pulsed oscillator to the input of the direct receiver and put the selector switch at C. Without altering the attenuator, tune the direct receiver and then adjust DIRECT GAIN to give a test pulse 1 cm. high.
- (10) Put the selector switch at D. Switch off the pulsed oscillator and put the maintenance switch at NORMAL. Both neons will now be extinguished and a trace will only be obtained if the IFF A-BAND key on display unit Type 5 is ON.
- (11) Remove the test leads and plug in the aerials to the receivers.

#### Daily setting-up

**73.** The daily maintenance is performed without reference to display unit Type 5 in the operations vehicle. The procedure is as follows:—

- (1) Switch on mixer unit Type 13, the two receivers and the transmitter.
- (2) Set the MTNC-NORMAL switch to MTNC (the warning neon should glow); transmitter Type T.3117 and the timebase circuits of the mixer unit will be locked from an internal source.
- (3) Set the selector switch at A and connect RF TEST on transmitter Type T.3117 to the wavemeter input with the test lead provided.
- (4) Set the wavemeter to the station frequency (using the calibration chart) and tune the transmitter (*para. 65 to 69*) to the wavemeter to obtain maximum transmitter pulse amplitude on the monitor display. The transmitter pulse appears as a thin vertical line near the beginning of the timebase.

#### Tuning the receivers Type R.3118A

**74.** The tuning procedure is as follows:—

- (1) Tune the oscillator control for maximum shadow angle on the magic eye.
- (2) Adjust the aerial and RF trimmers in the same manner.
- (3) Readjust the oscillator control.

#### Note . . .

*The dial readings of all three trimmers should be approximately the same. If they are not, it is an indication that the oscillator is tuned to an incorrect frequency and the procedure must be repeated. The relation between*

oscillator frequency and dial calibration is fairly linear; 2 on the dial corresponds to approximately 157 Mc/s, and 13 on the dial to approximately 187 Mc/s.

#### Switch unit Type 271 tuning

**75.** The switch unit should first be tuned by reference to the calibration chart fixed to it. Observe that the spark gaps are firing correctly by the appearance of a steady glow between their electrodes.

- (1) Set up a signal generator Type 53 and use it to feed a signal into the switch unit.
- (2) Observe the output from the receiver Type R.3118A on the monitor screen of mixer unit Type 13. Adjust the tuning knobs on the switch for maximum response. Do not turn the screws more than one complete turn in either direction.

## SETTING-UP IN THE OPERATIONS VEHICLE

### General

**76.** The two 230V mains supplies are made available to a number of circuits immediately the cables, numbers 41 and 51 (regulated supply) and number 70 (unregulated supply), are inserted into the appropriate plugs in the vehicle termination box if the corresponding switches in the

diesel vehicle are on. A summary of these circuits follows, together with the locations of switches. Fig. 24 shows the layout of the distribution board.

### Unregulated mains (circuit 2)

**77.** The main fuses for this circuit are T and U.

Supply to :—	Location of switch	Secondary fuse
Air conditioning control panel	On the panel ( <i>fig. 25</i> )	L
Plotting table and reflector lights	{ Distribution board, with a separate switch on each of three reflector lights	N
Rectifier unit (telephone)		Distribution board
Air blower	No switch	P
Three-pin sockets on each console	No switch	} Two fuses F3 and F4 on each console ( <i>fig. 27</i> )
Thermostat control on each console	No switch	

### Regulated mains (circuit 3)

**78.** The main fuses for this circuit are V and W.

Supply to :—	Location of switch	Secondary fuse
Consoles 1, 2 and 3	{ (i) Distribution board (ii) Console panel (to right of CRT unit)	{ Two fuses F <sub>1</sub> and F <sub>2</sub> on each console ( <i>fig. 27</i> )
Selsyn rotor in control unit Type 443	Distribution board (control unit circuit 3)	C
Battery charging unit	No switch	D
Rotors of selsyns in aerial vehicle (AMES Type 14)	No switch	No fuse
Rotors of selsyns in consoles 1 and 2	No switch	No fuse

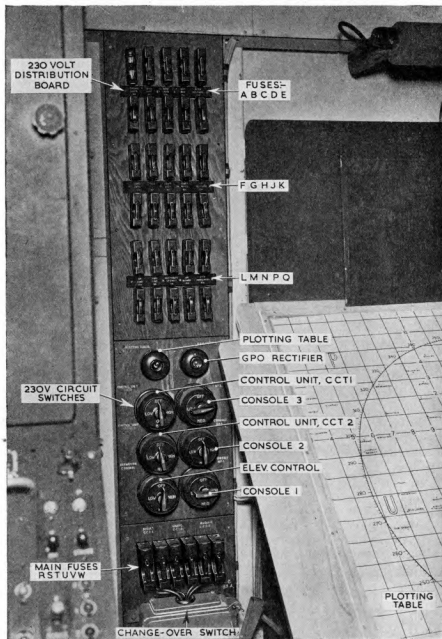

Fig. 24. R.V.467 : distribution board

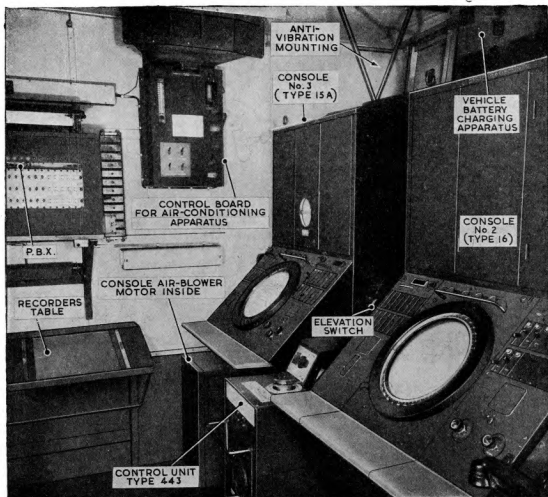

Fig. 25. R.V.467E : view towards front wall

**Regulated mains (circuit 1)**

79. This becomes available when the change-over switch, which is located at the bottom of the distribution board, is in the

down position. This is the normal position in the AMES Type 21 Mk. 5 installation. The main fuses for the circuit are R and S.

Supply to :—	Location of switch	Secondary fuse
230V lighting	Near side wall, just inside the door	H
Three wall sockets	Switch on each socket	J
Control unit Type 442	Distribution board (control unit circuit 1)	F
Jones R, then to line of light selsyns (consoles 1 and 2) and to repeater selsyn in aerial vehicle Type 13	No switch	No fuse

**WARNING**

It should be remembered that certain mains circuits are live as soon as the supplies are plugged into the vehicle termination box. Care should be taken when servicing the equipment. For example, in consoles 1 and 2, the 230V supply is present on panels 48 and 6 (console termination panel and indicating unit Type 115); in console 3, it is present on panel 45 (console termination panel). The thermostatically controlled console heating system is also alive.

**Switching on the consoles**

80. On each console :—

- (1) Close the switch on the distribution board.
- (2) Close the switch on the desk at the right-hand side of the CRT unit.

**Switching on the aerial turning control units**

Control unit Type 442

81. Close the switch on the distribution board (control unit circuit 1).

Control unit Type 443

82. Close the switch marked CONTROL UNIT CIRCUIT 3 on the distribution board and the switch on the control unit marked SUPPLY.

**Switching on the elevation tilting motor**

83. Close the master switch in the aerial vehicle and the ELEVATION CONTROL switch on the distribution board in the operations vehicle. Close the elevation switch at the side of console 3.

**Plotting tables**

84. The navigator's table is that against the off-side wall at the rear of the vehicle. A vertical plotting table is fitted to the rear wall. Table illumination is controlled by variable resistances at the side of each of them. Overhead reflector lights with individual switches on the lamp holders are also provided for the navigator's table. There is a third plotting table, immediately

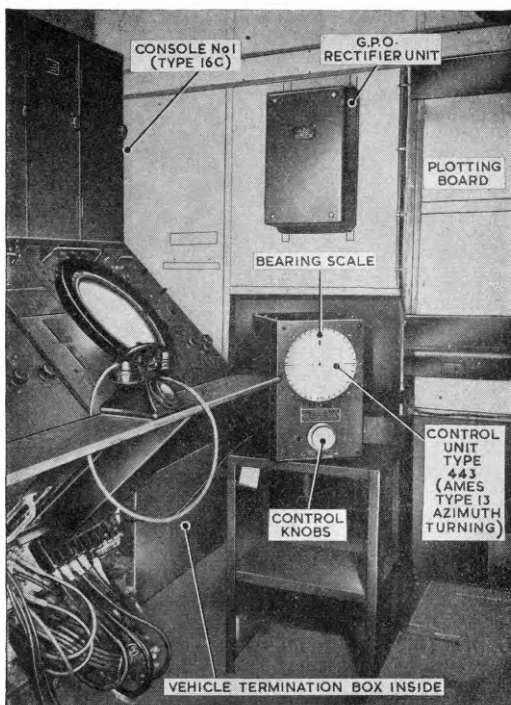

Fig. 26. R.V.467E : view towards rear wall

to the left of the main door, which may be folded when not in use; this is the recorder's table.

**Air-conditioning equipment (fig. 25)**

85. This equipment (apparatus kit Type 40) is mounted on a bracket above the driver's cab and the control panel for it is located on the container front wall. Its purpose is to keep the interior of the vehicle warm in temperate climates and cool in tropical climates; it has no connection with refrigeration plant R.V.181B.

86. The heating equipment consists of a motor and seven heater units of 475 watts each. Two fans, on a common shaft, are driven by the motor; air is drawn in through a filter situated over the heaters

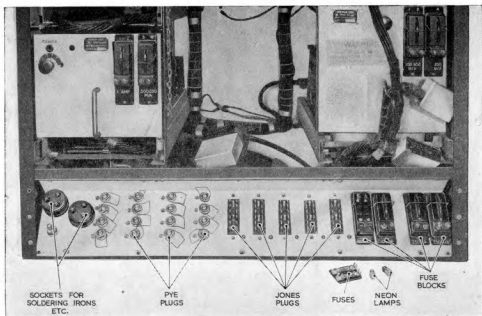

Fig. 27. Panel Type 520

and is passed to the interior of the vehicle through an expansion chamber.

#### Ventilation

**87.** If it is required to use the equipment for ventilation only, the procedure is as follows :—

- (1) Start the fan by switching ON MAINS.
- (2) Close the AIR RECIRCULATION CONTROL.
- (3) Control the ventilation by means of the AIR SUPPLY CONTROL lever.

#### Ventilation and heating

**88.** Switch on MAINS, then switch on the heaters progressively until the desired temperature is reached. Allow sufficient time for each heater to warm up before switching on the next.

#### Note . . .

*The four heater switches are inoperative until the MAINS switch is on.*

**89.** The 1ST HEAT switch operates one heater circuit, and the other three operate two heater circuits each. If a further increase in temperature is required, open the AIR RECIRCULATION CONTROL; for still greater heat, move the AIR SUPPLY CONTROL

lever to the right to decrease the flow of air entering the vehicle. When the requisite temperature is reached, the air supply should be increased. To prevent overheating, a thermostat is included which cuts out the heaters at a temperature of 150 deg. F.

#### Refrigerator plant

**90.** Some AMES Type 21 Mk. 5 convoys include a refrigeration plant (air cooling unit Type 2 or 4) which is carried in a trailer. The trailer is radio vehicle Type 181B and it is attached to radio vehicle Type 467.

**91.** Hot air is extracted from the operations vehicle via a canvas duct and passed over the cooling unit contained in the trailer vehicle. After cooling, the air is returned to the operations vehicle via a second canvas duct. The complete unit is shown in Chap. 2, fig. 37,

#### Console blower system

**92.** This system is quite separate from the air conditioning apparatus already described; it is used to circulate cool air through the consoles.

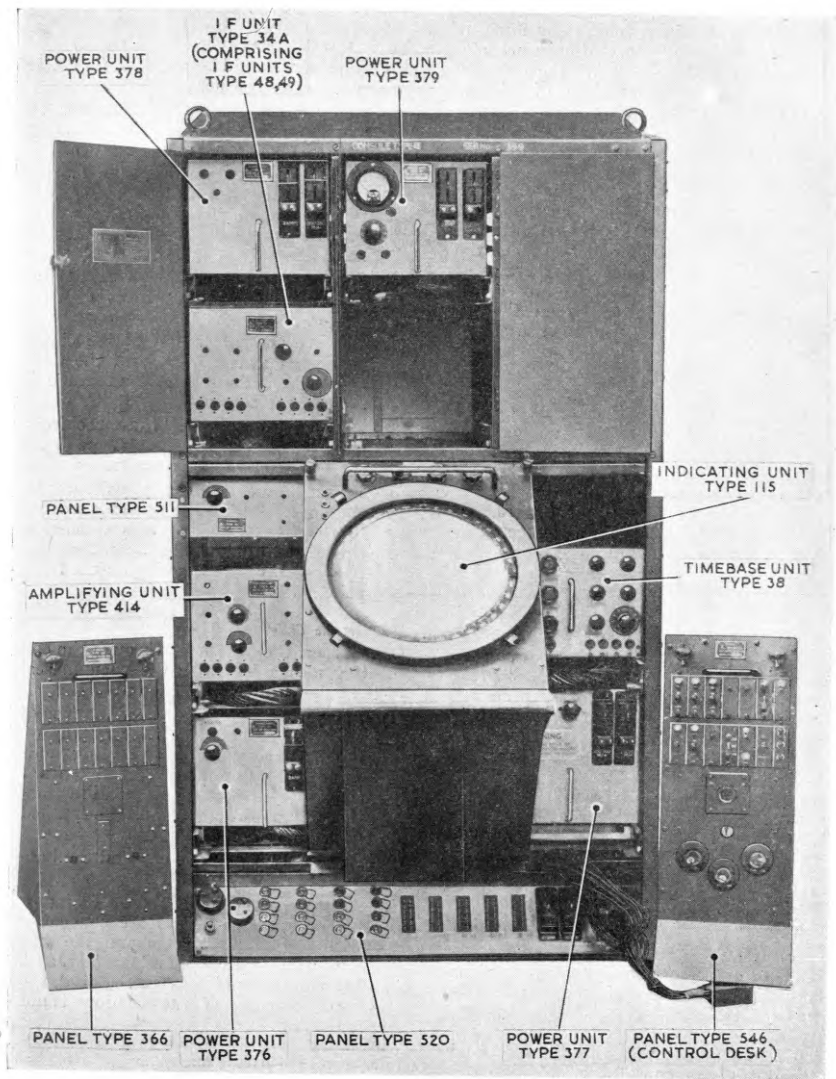

Fig. 28. Console No. 1 (Type 16C)

**93.** A blower motor, in a compartment to the left of console 3, draws air through a filter at the side of the vehicle and forces it through ducts at the base of each console. The cool air circulates round the consoles and passes out through a series of holes at the tops of the rear panels whence it passes through a flexible rubber duct to the vehicle exterior.

**94.** In the base of each console, two thermostatically controlled heaters are fitted. The thermostats may be adjusted over a range of 10 to 90 deg. C. When the ambient temperature falls, the thermostat contacts operate, the blower motor stops, and the heaters operate. When the set temperature is reached, the reverse action takes place.

**95.** To set up the system, it is only necessary to turn the thermostat control knob to the desired operating temperature. The temperature of the consoles may be controlled by any one of the three thermostats, depending on the connections of the leads to the blower motor (*Chap. 2, para. 67*). For example, if the leads are connected to L3, L11, then control is by the thermostat on console 3.

## WARNING

*Efficient console cooling is only possible when all panels and doors are closed; otherwise, the cool air from the blower is not properly circulated. The heaters should be made to cut out at a reasonably low temperature. A normal setting for the thermostat is 20 to 30.*

## CONSOLES 1 AND 2

### General

**96.** Console 1 (console Type 16C) (*fig. 28*) provides :—

- (1) Plan-position display of radar information.
- (2) Mk. 3G IFF display on the same CRT.

**97.** Console 2 (console Type 16) provides plan-position display of radar information (*fig. 29*).

**98.** Before proceeding with the electrical setting-up of the consoles, ensure that the CRT'S are fitted correctly and that the coil rotating mechanisms are properly adjusted. A check should be made to see that the

correct type of perspex window is fitted (window Type 41, 42 or 85).

### To fit a cathode-ray tube (*fig. 30 and 31*)

**99.** The tube should be prepared for fitting in the following manner :—

- (1) Remove the mumetal box cover by loosening the four wing nuts securing it to the coil rotating mechanism.
- (2) Loosen the two vertical slide locking screws, the lateral locking screw, and the two swivel locking screws. A spanner is provided, and it is attached to the left-hand side of the coil rotating mechanism.
- (3) Set the swivel, lateral and vertical slide adjustments to the centres of their ranges.
- (4) Remove the upper half of the clamp which supports the neck of the CRT and loosen the height and traverse adjustment screws.
- (5) Remove the spinning from the front panel of indicating unit Type 115; it is secured by four spring-loaded clips.
- (6) Fit the mumetal screen in position with the slot upwards. The screen is secured to the front panel springs which are threaded through holes near the periphery of the tube opening on the front panel.

### To insert the CRT

**100.** Insert the CRT neck through the coil rotating mechanism with the vacuum seal of the tube to the top. Then :—

- (1) Place the PPI window over the face of the CRT and replace the spinning on the front panel of indicating unit Type 115. Care should be taken not to break any of the eight rear illumination lamps which should be pushed back for the operation.
- (2) Place the CRT anode cap and the base socket in position.
- (3) Adjust the position of the CRT window until the range circles are concentric with the azimuth scale and the grid lines run vertically and horizontally. If an off-centre display is required, the exact centring of the window is not important.

### To adjust the coil rotating mechanism

**101.** This is done as follows :—

- (1) Loosen the four screws which secure the mechanism to the unit chassis.

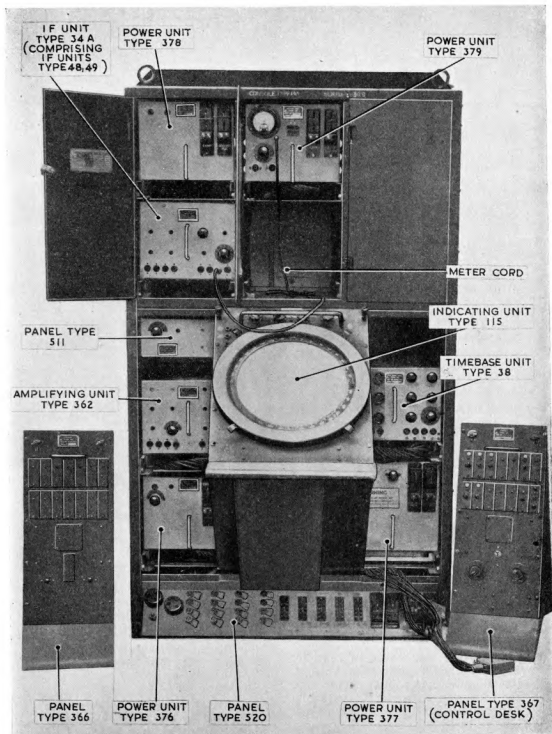

Fig. 29. Console No. 2 (Type 16)

- (2) Remove the upper portion of the CRT clamp and the CRT base.

- (3) Slide the mechanism forward until the deflector coils are approximately one-eighth of an inch from the flare of the CRT. Where the line-of-light mechanism (follower unit Type 4) is fitted, it will be impossible to see the front of the deflector coils, but the adjustment may be made with the use of the feeler gauge provided. The feeler gauge consists of a metal tube slightly larger in diameter than the neck of the CRT. When not in use, it is kept in two clips at the right of the CRT flare close to the base of the chassis. With the CRT in position, the gauge is placed over the neck of the tube with the white ring to the rear until it comes up against the flare of the tube. Some resistance to movement may be encountered, in which case, the vertical, lateral or swivel adjusting screws may require slight adjustment to enable the tube to slide easily. As the tube is pushed to its extent, it will be noticed that the white calibration mark is close to the rear edge of the focus coil. The coil rotating mechanism should be moved until the front edge of the white mark lines up with the rear edge of the coil.
- (4) Tighten the screws securing the mechanism to the chassis.
- (5) Line up the timebase coils centrally about the CRT using the vertical, lateral and swivel adjustments so that the feeler gauge may be rotated freely between the CRT neck and the timebase coils.
- (6) Tighten the vertical, lateral and swivel adjustments and remove the feeler gauge.

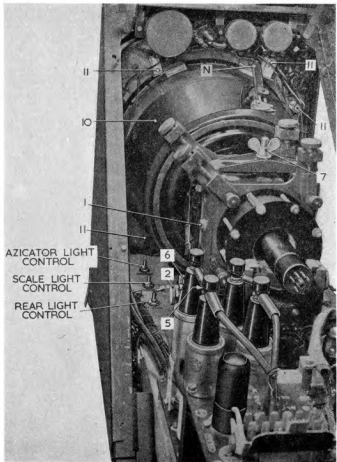

Fig. 30. Indicating unit Type I15 : interior

- (7) Replace the upper portion of the CRT clamp, and tighten the traverse and height adjusting screws. Care should be taken that the CRT does not move during this operation.
- (8) Replace the mumetal box cover ; to do this, it may be necessary to slacken the vertical adjusting wing nut until it is parallel with the slot in the cover.
- (9) Fit the CRT base socket.

#### To remove the CRT

**102.** Remove the mumetal box cover and the upper portion of the CRT neck clamp. Loosen the height and traverse adjustment locking screws. Remove the CRT base socket and anode cap. Remove the spinning from the front of the indicating unit.

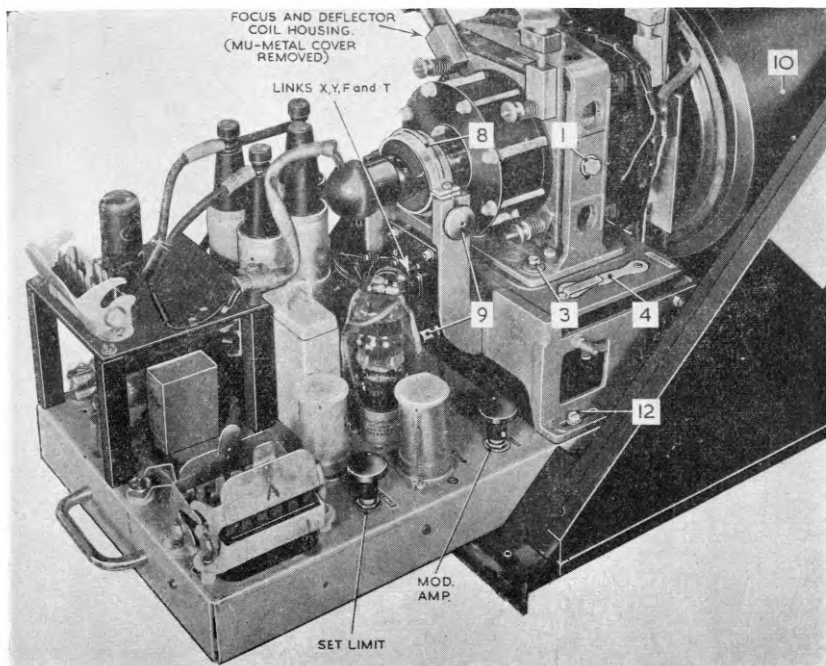

Fig. 31. Indicating unit Type 115: interior

#### To change the PPI window

**103.** Remove the mumetal box cover and the upper portion of the CRT clamp. Remove the spinning and the window from the indicating unit. Place the new window in position and replace the spinning. Check the adjustment of the timebase coils with the feeler gauge; if adjustment seems necessary, follow the instructions given in para. 101.

#### Setting-up consoles 1 and 2

**104.** The method of setting-up console 2 is similar to that for console 1. Where there are any differences they are detailed, otherwise the procedure given applies to both.

#### Preliminary adjustments

- 105.** These should be made as follows:—
- (1) Turn on the console wall switch (*fig. 24*).
  - (2) Switch off the following control desk keys:—

- (a) AZIM IND.
- (b) N.B.W.
- (c) S.T.C.
- (d) L.P.F.
- (e) A.P.I.

- (3) Ensure that the control desk mains switch is OFF.
- (4) Withdraw amplifying unit Type 414 (console 1 only). Turn the BIAS control, which is located on the rear of the small sub-chassis at the rear of the unit, to minimum, i.e., counter-clockwise.
- (5) Turn the BRIGHTNESS control on the front panel of indicating unit Type 115 to minimum.

#### To adjust the focus coil

**106.** Remove the shift coil links; these are labelled x and y (*fig. 31*) and are plugged

into sockets at the rear of the CRT base clamp inside indicating unit Type 115. Then proceed as follows:—

- (1) Remove the HT fuses from power units Type 378 and 379. The right-hand fuse box in each power unit holds the HT fuses: in power unit Type 378, both fuses should be removed, whilst in power unit Type 379, only the 500mA fuse should be removed (*fig. 28 or 29*).
- (2) Switch on the console with the control desk ON-OFF switch, and wait for 30 seconds.
- (3) Turn the BRIGHTNESS control (indicating unit Type 115 front panel) until an unfocused spot appears in the centre of the CRT. Mark the position of the spot on the screen.
- (4) Switch off the console and replace the fuse in power unit Type 379. Be careful to fit the fuse carrier the right way up as it is possible to interchange the fuses.
- (5) Switch on the console and adjust the focus coil using the two screws (*fig. 32*). The adjustment must be made so that as the FOCUS control is rotated backwards and forwards, the spot expands and contracts about a fixed point on the screen. This point will be near to that marked in (3).
- (6) Adjust the FOCUS control to give a sharply focused spot and switch off.

#### Timebase synchronization

**107.** The display unit timebases are normally locked to the transmitter pulse which ensures that the timebases start at the same instant as the transmission of pulses of RF energy from the aerial. It may be occasionally necessary to set up the display unit without having the transmitter switched on. To allow for this contingency, a local pulse oscillator (L.P.O.) is embodied in panel 26, power unit Type 379. Its

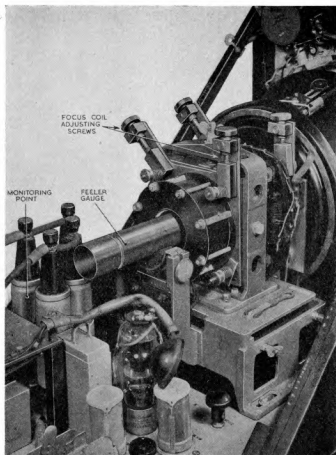

**Fig. 32.** Indicating unit Type 115: interior

operation is controlled by a switch on panel Type 511 (*fig. 28 or 29*) which has four positions, viz. :—L.P.O.—T11—T13—T14.

**108.** When the switch is turned to L.P.O., the local pulse oscillator is switched on. The T11 position concerns AMES Type 11 and Type 15 Mk. 3 stations only, and is used where the transmitter locking pulse is negative-going. The third and fourth positions are for transmitters with positive-going locking pulses; these include AMES Type 21 Mk. 5.

**109.** Turn the L.P.O. switch to position 1 and turn the knurled L.P.O. FREQ. wheel on power unit Type 379 (*fig. 33*) until the mark on the wheel coincides with the white cursor on the panel; the local pulse oscillator will then deliver pulses at 500c/s. If the

transmitter sync. pulse is required, turn the switch to position 3.

To adjust the trace

**110.** Set the X SHIFT and Y SHIFT controls on the front panel of indicating unit Type 115 to their mid-way positions.

- (1) Replace the X and Y links in the shift circuit (*para. 106*).
- (2) Replace the fuses in power unit Type 378, and switch on the console.
- (3) If the start of the time-base trace is well off centre, it will be necessary to reverse one or both of the links X and Y. Bring the start of the trace to the geometrical centre of the tube (the station position indicated by the grid lines on the window) using the X SHIFT and Y SHIFT controls.

- (4) Monitor the cathode current of stabilizer valve V3 in power unit Type 379. To do this, set the METER switch on power unit Type 379 to position 11 and insert one end of the monitoring lead into the meter socket; insert the other end of the lead into socket V3C of power unit Type 378. The meter reading should be 0.4mA. If it is not, withdraw power unit Type 378 and adjust the pre-set control just behind the front panel until the reading is correct. This operation should not be done until the equipment has been switched on for at least two minutes.

- (5) Turn the MOD AMP and SET LIMIT controls, at the left-hand rear of indicating unit Type 115, fully clockwise, and then turn them back a quarter turn.
- (6) Switch on the CAL key on the control desk.
- (7) Lower the right-hand control desk to expose timebase unit Type 38 (*fig. 28 or 29*) and adjust the SYNC control (top right knob) on that unit so that a steady trace appears on the indicating unit.

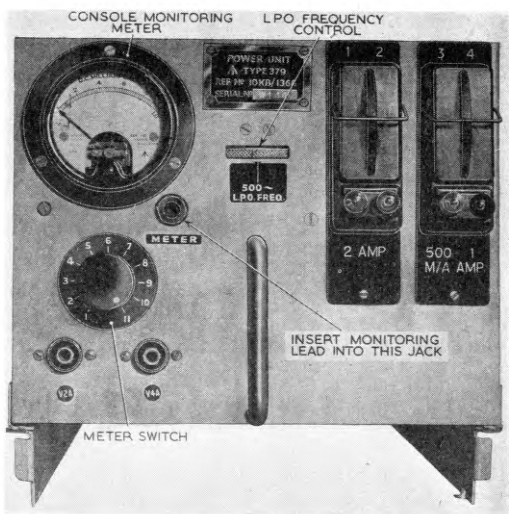

**Fig. 33. Power unit Type 379**

- (8) Turn the BRIGHTNESS control on time-base unit Type 38 fully counter-clockwise.
- (9) Turn the BRIGHTNESS control on the front panel of indicating unit Type 115 until the trace is just blacked out.
- (10) Re-adjust the BRIGHTNESS control on the timebase unit until the trace reaches normal brilliance.

#### Range calibration

**111.** Three ranges are available. The general requirements of the equipment are for timebases corresponding to 30, 60 and 90 miles in length on ranges 1, 2 and 3 respectively. The required range is selected with the RANGE key on the control desk (*fig. 28 or 29*). The timebases are adjusted by means of the VELO, LIN and RANGE potentiometers on the front panel of time-base unit Type 38. There are three controls for each range.

**112.** The method of adjustment is :—

- (1) Switch on the CAL key on the control desk, and set the RANGE key to the range to be calibrated.

- (2) Adjust the RANGE control on the time-base unit until the required number of calibration pips appears on the time-base (e.g., six pips on range 1, 30 miles).
- (3) Adjust VELO and LIN controls until the first, centre and last pips lie on the appropriate range circles on the tube.
- (4) Repeat the three operations for the other two ranges.

#### Limiting adjustment

**113.** The limiting and modulation intensity controls on amplifying unit Type 414 (amplifying unit Type 362 on console 2) and indicating unit Type 115 are set up as detailed below to give optimum painting with minimum signal amplitude. When the setting-up has been done, only the BRIGHTNESS and GAIN controls may be altered subsequently. If it is desired to alter any other controls, the entire procedure must be repeated.

- (1) Set IF GAIN to maximum, and then back a quarter turn.
- (2) Switch on the CAL key on the control desk.
- (3) Adjust the BRIGHTNESS control (indicating unit) until the calibrator pips are at normal working brilliance.
- (4) Switch off CAL.
- (5) Withdraw amplifying unit Type 414 (amplifying unit Type 362 in console 2). Turn the BIAS control (console 1 only), which is located on a small sub-chassis, fully counter-clockwise. Turn the AMP LIMIT control until signals and noise paint adequately along the whole trace.

#### Note . . .

*The setting of the BIAS control (console 1) may require some adjustment to arrive at an optimum setting for the display of IFF and radar signals. At a minimum setting the radar signals may be blacked out (para. 118(5)).*

- (6) Adjust the SET LIMIT control on indicating unit Type 115 until the noise only just paints.
- (7) Adjust the MOD AMP control on the indicating unit to give correct signal intensity with no halo around the signals.
- (8) Check the setting-up by switching CAL on and off; there should be no difference in brilliance levels.

**114.** Check, on each range, that the noise paints and that the modulation intensity level is satisfactory. Recheck focusing and calibration. Under operational conditions, it may be found necessary to make slight alteration to the front panel BRIGHTNESS control when switching from range to range.

#### Limiting adjustment (using oscilloscope Type 10)

**115.** Connect the output from the cathode of V3 in indicating unit Type 115 to the Y-plate of an oscilloscope Type 10 and a picture of noise and signals should be displayed. A convenient monitoring point is the metal can of either of the two high-voltage condensers at the right of the CRT (*fig. 32*).

#### WARNING

*The top terminals of these condensers are at a potential of 5kV from earth; great care must be exercised when performing the operation.*

**116.** The oscilloscope timebase may be synchronized from the waveform at the socket marked V2A on timebase unit Type 38. A suitable display will be obtained with the oscilloscope timebase switch at position 3 or 4.

**117.** Proceed to set up the indicator as follows:—

- (1) Check that the IF amplifier is not overloaded. The IF GAIN control should be turned clockwise to the point where no further increase of signal strength is observed on the PPI.
- (2) Adjust the SET LIMIT control and observe its effect on the oscilloscope waveform. A position will be found where the noise reaches the same amplitude as the signal after which both signal and noise decrease. The control must be set to give equal amplitudes of signal and noise. This ensures that extremely weak responses paint adequately.
- (3) Adjust the MOD AMP control for the required intensity modulation level. This can be done by watching the indicating unit trace. There should be no halo around the echoes, but at the same time, noise should be visible along the whole length of the trace.

- (4) As a final check, switch on the CAL key on the control desk. Calibrator pips should have the same intensity as signals if the controls have been correctly set. Test each of the three ranges in turn.

#### G-band IFF facilities on console 1

**118.** It will be necessary to switch on the G-band transmitter and receiver, and to employ a signal generator Type 53 or other signal source to do the following operations:—

- (1) Use the oscilloscope to observe the output at terminal 3 of the matching transformer to the left of the row of Jones sockets in the vehicle termination box (*Chap. 2, fig. 40*).
- (2) Adjust the IFF GAIN control on the console control desk until the ratio of signal-to-noise is 3-to-1 on a signal which just saturates. Lock the IFF GAIN control. Disconnect the oscilloscope lead from the transformer.
- (3) Display the waveform at V3 cathode (indicating unit) on the oscilloscope. The best point for monitoring is described in para. 115.
- (4) Remove the radar IF input lead from the console (P1 of panel Type 520).
- (5) Adjust the BIAS control on amplifying unit Type 414 (amplifying unit Type 385 on console 2) so that IFF noise just fails to show. The BIAS control should not be touched again unless the entire procedure is repeated (*para. 113 (5)*).
- (6) Use the IFF GAIN control at as low a setting as possible since IFF noise interferes with the radar display.

#### Narrow bandwidth unit

**119.** The setting-up of this unit is as follows:—

- (1) Switch on the N.B.W. key. Set N.B.W. TUNE to the midway position.
- (2) Connect an oscilloscope as detailed in para. 115. Turn down IF GAIN so that

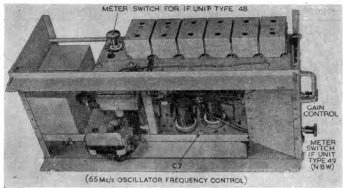

**Fig. 34.** IF unit Type 34A: interior

the observed signal-to-noise ratio becomes about 3 : 1.

- (3) Withdraw IF unit Type 34A and identify the oscillator control C7 which is between V1 and V2 (*fig. 34*). Tune C7 for maximum signal amplitude.
- (4) Switch off the N.B.W. key and note the effect of this on the signal. If the signal decreases in amplitude, adjust the GAIN control on the front panel of IF unit Type 34A. Repeat this operation until there is no difference in signal amplitude as the N.B.W. key is switched in and out.

#### IF gain control

**120.** If this control is turned fully clockwise, overloading of the IF unit may occur. To set it correctly, turn first to minimum and then clockwise until noise appears along the whole length of the indicating unit trace. Any further clockwise movement will not increase the signal amplitude; in fact, towards the fully clockwise position, there may be a drop in signal amplitude. The best position has been found to be about a quarter turn from maximum.

#### To set up the line of light

**121.** Before attempting to set up the line of light, ensure that the mechanism has been correctly centred and that the PPI window has been set with its range circles concentric with the azimuth scale. The following table lists the adjustments which may be made to the system.

No.	Adjustment	Effect	Method
1	To make the lamp filament parallel to the slot in the lamp housing	Brilliance	Rotate the lamp holder with respect to the housing until the lamp filament and the slot in the housing are parallel.
2	To make parallel the slots in lamp and lens housings	Focus of line of light	Rotate the lamp housing with respect to the lens housing until the definition of the line of light is good all the way along.
3	To set the distance between the slot in the lamp housing and the lens	Focus of line of light	Insert or withdraw the lamp housing (taking great care not to upset adjustment 1 or 2) until best focus is obtained.
4	To set the axis of the lens with respect to that of the mirror	Focus	Rotate the lens housing (being careful not to disturb any previous adjustment) until best definition is obtained.
5	To swivel the lamp housing with respect to the arm carrying the mirror	Focus	Swivel the housing until the light from the lens falls on to the centre line of the mirror.
6	To adjust the distance between lens housing and mirror	Brilliance	Adjust the position of the lens housing until it just clears the mumetal screen when the line of light mechanism is rotated ( <i>fig. 37</i> ).
7	To adjust the tip of the mirror-carrying-arm	Position of line of light on the tube face	Release the adjusting screw and move the arm carrying the mirror until the mirror just clears the side webs and bottom of the chassis when rotating. Lock the adjustment ( <i>fig. 37</i> ).
8	To set the mirror inclination	Length of line of light	Slacken the screw holding the mirror to the arm and adjust the angle of the mirror so that the line of light runs from the centre of the tube face to the edge. Tighten the securing screw ( <i>fig. 37</i> ).
9	To adjust the swivel of the mirror carrying-arm	Centring of line of light	Slacken the locking screw, and adjust the swivel of the arm by slackening one set-screw and tightening the other until the line of light passes through its centre of rotation. Tighten the locking screw ( <i>fig. 37</i> ).
10	To adjust the position of the axis of the line of light with respect to the chassis	Position of centre of line of light on the tube face	Slacken the locking nuts for lateral adjustment, and by means of the lateral adjustment screws set the centre of rotation of the line of light to coincide with the centre of rotation of the PPI timebase ( <i>fig. 36</i> ).

Adjustments 1, 2, 3 and 4 are locked by the slotted locking screw on the lens housing shown in fig. 37.

Adjustments 5 and 6 are locked by the knurled nut on the lamp, also shown in fig. 37.

122. The adjustments given in the table should be done in the following manner:—

- (1) Set the lateral adjustment of the line of light so that the gearbox is approximately concentric with the CRT (adjustment 10).
- (2) Adjust the angle of the arm carrying the mirror (adjustment 7).
- (3) Adjust the distance of the lens housing from the mirror (adjustment 6).
- (4) Roughly adjust the swivel of the light housing so that a line of light is produced on the tube in order to facilitate further adjustment (adjustment 5).
- (5) Roughly adjust the inclination of the mirror (adjustment 8).
- (6) Make adjustments 1, 2, 3 and 4 of the table very carefully and tighten the locking screw.
- (7) Swivel the lamp housing with respect to the arm carrying the mirror until best focus is obtained; tighten the lock-nut (adjustment 5).
- (8) Set the angle of the mirror so that the line of light runs from the centre of the CRT face; tighten the locking screw (adjustment 8).
- (9) Set the swivel on the arm carrying the mirror so that the line of light passes through a point on the tube face as the mechanism is rotated (adjustment 9). This adjustment is made by first finding the centre of rotation and then adjusting the line of light to pass through it (*para. 123*).
- (10) Adjust the position of the axis of the line of light by means of the lateral adjusting screws to bring the centre of rotation of the line of light to the centre of the azimuth scale (adjustment 10).

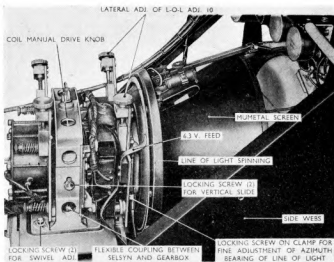

Fig. 35. Follower unit Type 4: assembly of coil rotating mechanism

123. It will be found that as the mechanism is rotated the line of light moves so that it is a tangent to a circle. When correctly adjusted, the line of light must pass through the centre of the circle. The centre is found in the following manner:—

Rotate the mechanism so that the line of light runs vertically in an upward direction and note its position. Repeat with it running vertically downwards, then horizontally to the right and horizontally to the left, noting its position in each case. The four lines so found form a square whose centre is the centre of rotation. The grid reference lines on the CRT window will form a useful guide during the operation.

### CONSOLE 3

#### General

124. Console 3 (Type 15A), which is illustrated in fig. 38, provides:—

- (1) A height-range display with two ranges; 75 or 150 miles.
- (2) Mk. 3 IFF display and AMES Type 14 radar display on separate timebases.

#### Preliminary adjustments

125. Proceed with preliminary adjustments as follows:—

- (1) Fit the cathode-ray tube. To do this, remove the CRT spinning and the tube

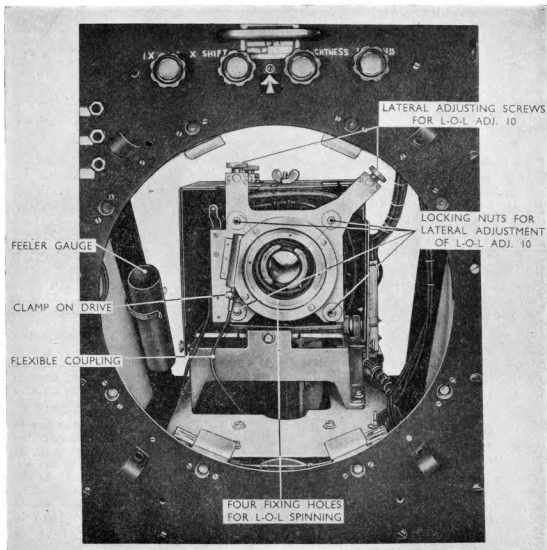

Fig. 36. Follower unit Type 4: front view

- (1) clamp and insert the tube, a CV1528. Replace the clamp and spinning and fit the base socket. It may be necessary to rotate the tube slightly after fitting in order that the timebase trace may be horizontal.
- (2) Check that the Y deflection links on the underside of indicating unit Type 114 are set for elevation deflection (*Chap. 2, para. 74*).
- (3) Ensure that all the control desk keys are off (*fig. 38*).
- (4) Rotate the control marked BRIGHTNESS at the top of the front panel of indicating unit Type 114 fully counter-clockwise.
- (5) Lower the right-hand control desk to expose panel Type 566 or 509 (*fig. 38*). Set the BLANKING switch on that panel to position 2 (EL SCAN). Set the SYNC switch to L.P.O. (*para. 107 to 109*).
- (6) Replace the control desk and switch on the console, not forgetting to ascertain that the wall switch is on.

- (7) When the equipment has been switched on for at least two minutes, monitor the cathode current of the stabilizer valve in power unit Type 375 with the selector switch on that unit in position 8. The reading should be 0.4 mA. If it is incorrect, adjust it by means of the pre-set potentiometer, ADJUST STABILISER, just behind the front panel.

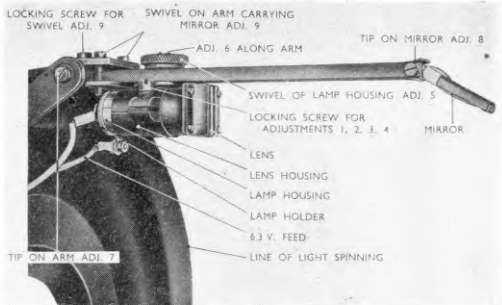

Fig. 37. Follower unit Type 4: optical system

#### To set up indicating unit Type 114

126. Great care should be taken at all times when turning up the BRIGHTNESS control on indicating unit Type 114, since the screen of the CV1528 is easily damaged by excessive brilliance.
- (1) Set the pulse repetition frequency as described in para. 109.
  - (2) Depress the CAL key on the control desk, then lower the desk and adjust the SYNC control (top right-hand knob on timebase unit Type 37) until the trace remains steady.
  - (3) Turn BRIGHTNESS (timebase unit Type 37) fully counter-clockwise.
  - (4) Adjust the indicating unit BRIGHTNESS control until the trace is just blacked out.
  - (5) Turn the BRIGHTNESS control on the timebase unit until the trace assumes normal brilliance. This control should not be touched again; any subsequent adjustments in brilliance should be made with the indicating unit control.
  - (6) Obtain a sharply defined trace using FOCUS, X STIG and Y STIG controls. First move the X STIG control over a few degrees, then adjust the FOCUS control, observing the calibrator pips at the end of the trace. Repeat the operation until the setting for optimum focus is found. Next, adjust Y STIG observing the tips of the calibrator pips. After each movement of the stig controls, a slight pause should be made since there is a small delay before the effects of the adjustments become apparent.

#### Focus and first anode tapping points

127. If, after performing the operations detailed in para. 126, it is obvious that the focus of the trace is poor, it may be necessary to alter the tappings on power unit Type 451 which is disclosed by lowering the right-hand control desk. The power unit must be removed from the console to alter the tappings which are located on a tag-board at the rear left-hand side of the chassis (fig. 39).

128. Fig. 40 shows the normal connections of the supply to the first anode and FOCUS potentiometers. The FOCUS potentiometer is connected across links 2 and 3, 3 and 4, or 4 and 5 so that there is always one 330K resistor in parallel with it. In order to maintain the same voltage difference between the first anode and the focus anode, the first anode should be connected across links 1 and 2 when the focus anode is connected across 3 and 4, and across 2 and 3 when the focus anode is connected across 4 and 5.

129. If it is found that the best focus is obtained at an extreme position of the FOCUS control, a cure may be effected by changing the shorting bar from position A at the front of the tag-board to position B at the rear.

#### Timebase adjustment

130. Two ranges are provided. These are:—

- (1) Range 1 which covers 0–75 miles.

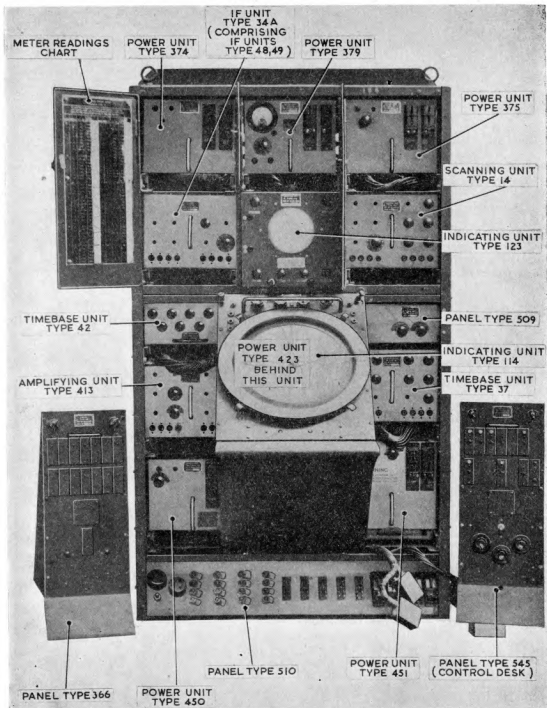

Fig. 38. Console No. 3 (Type 15A)

(2) Range 2 which covers 0-150 miles.

The scales for both ranges are engraved on the illuminated scale which is fixed to the CRT spinning.

**131.** The procedure for adjusting the time base is as follows :—

- (1) Switch the control desk key to RANGE 1.
- (2) Adjust the RANGE 1 control on timebase unit Type 37 so that there are 15 calibrator pips. A control adjacent to valve V7 in indicating unit Type 114 is provided to allow the intensity of the calibrator pips to be varied. The first calibrator pip corresponds to a range of five miles.
- (3) Adjust the X SHIFT control (indicating unit Type 114) and the VELO 1 COARSE switch (timebase unit Type 37) in rotation so that the five mile pips become approximately aligned with the range scale divisions. The first or second switch position (clockwise) will generally give the desired result.
- (4) Use the X SHIFT control (indicating unit Type 114) and the VELO 1 FINE control (timebase unit Type 37) to line up the calibration pips with the range scale exactly.
- (5) Switch the control desk key to RANGE 2. Repeat operations 1 to 4 using the controls appropriate to range 2 so that there are 30 pips which correspond with the markings on the 0-150 miles scale.

#### Video signal chain

**132.** The radar transmitter or other signal source (e.g., a signal generator Type 53) and the receiver must be on in order to make the following adjustments :—

- (1) Lower the right-hand control desk and turn the SYNC switch to position T14.
- (2) Replace the control desk and set the GAIN control almost to maximum. Ground ray and permanent echoes should be displayed.

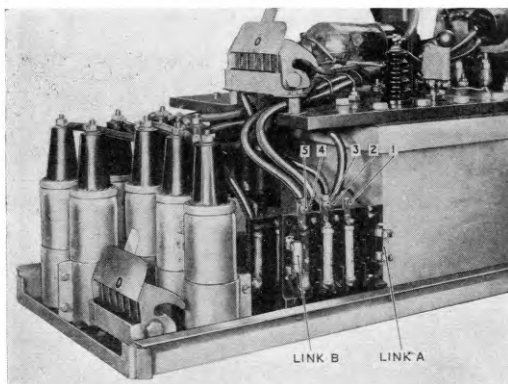

**Fig. 39.** Power unit Type 451 : interior

- (3) The setting-up of the limiters is similar to that for consoles 1 and 2 (*para. 113*).

#### Narrow bandwidth unit

**133.** This should be set up as follows :—

- (1) Turn on the N.B.W. key and set N.B.W. TUNE to its midway position : both controls are on the control desk.
- (2) Withdraw IF unit Type 34A and identify the oscillator control C7 which is between valves V1 and V2 as seen from the left-hand underside of the unit (*fig. 34*). Tune the oscillator for maximum signal amplitude, using an oscilloscope.
- (3) Switch off the N.B.W. key and observe the effect on a permanent echo. If the echo decreases in amplitude, adjust the GAIN control on the front panel of IF unit Type 34A and re-check.

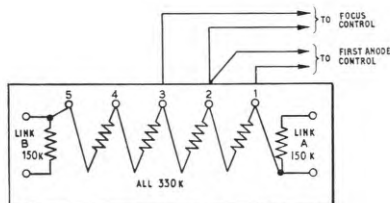

**Fig. 40.** Power units Type 377 and 451 : tag boards

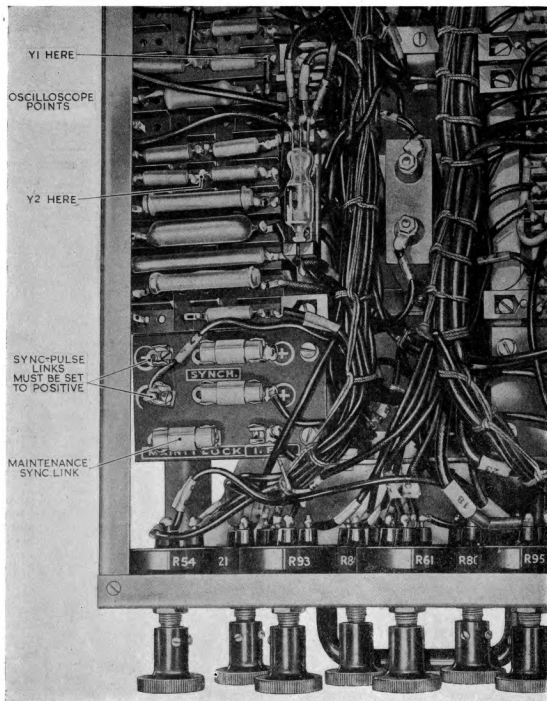

Fig. 41. Timebase unit Type 42 : sync link panel

Continue with adjustments until no difference in signal amplitude is observed as the N.B.W. key is switched on and off.

### Console 3 : IFF facilities

**134.** Indicating unit Type 123, which displays AMES Type 14 radar signals and IFF A-band signals, obtains its synchronizing pulses from the AMES Type 14 radar transmitter and mixer unit Type 13. It follows, therefore, that the radar transmitter must be operating before the A-band display can be set up. Unless the link on timebase unit Type 42 is in the MAINT position, the mixer unit Type 13 must be operating also (*fig. 41*).

#### Indicating unit Type 123

**135.** Verify that the appropriate range scale is fitted across the CRT face; the correct scale is 0—75 miles and 0—150 miles.

- (1) Place the A-BAND key OFF (right-hand control desk).
- (2) Lower the left-hand control desk and withdraw timebase unit Type 42. A link panel will be seen at the top of the chassis immediately behind the

DIVIDER control. The LOCK link should be set as indicated in para. 134.

- (3) Switch on the CAL key on the control desk of console 1 and turn the STROBE knob fully clockwise.

**136.** Two traces should now appear on indicating unit Type 123 but they will be intermittent. Make the following adjustments on the indicator front panel :—

- (1) Adjust the BRIGHTNESS control until the traces reach operating intensity.
- (2) Adjust X STIG and FOCUS for optimum overall focus.
- (3) Adjust Y STIG and FOCUS for optimum overall focus.
- (4) Re-adjust X STIG and FOCUS.

**137.** In the event of the focusing of the trace being unsatisfactory, a remedy may be sought in the same manner as for indicating unit Type 114 (*para. 127*), that is, alteration of the focus coil tappings. The taps are located at the right-hand side of indicating unit Type 123 at the rear of a tag board (*fig. 42*). As in the case of indicating unit Type 114, there is a shorting bar which may occupy one of two positions

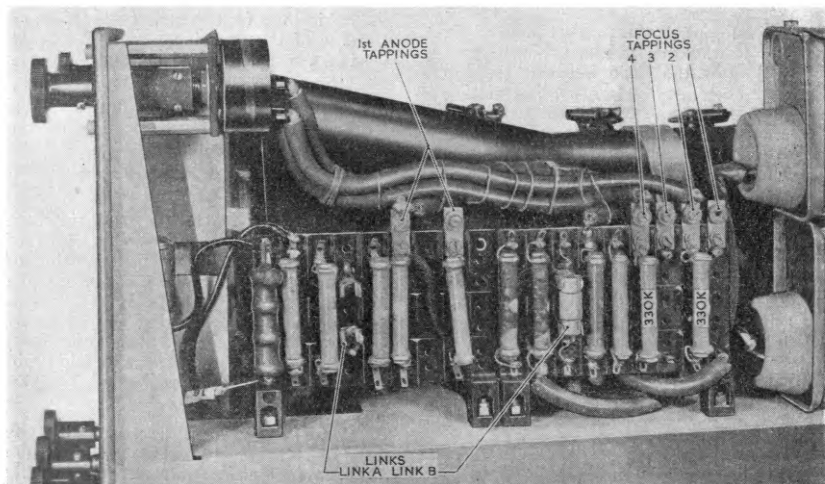
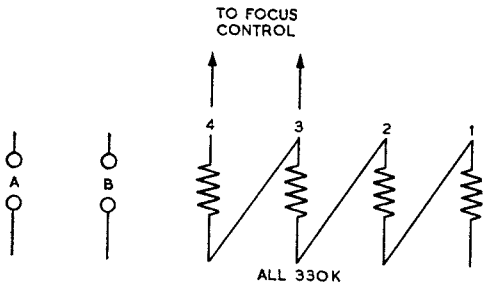

Fig. 42. Indicating unit Type 123 : focus and first anode tapping points



**Fig. 43.** Indicating unit Type 123 : links A and B and focus control tappings

so that optimum focus is obtained with the focus control approximately at the mid-point of its travel.

#### Timebase unit Type 42

**138.** Before attempting to set up this unit, verify that the SYNCH links (*fig 41*) are set for positive operation.

- (1) Ensure that the radar transmitter is operating.
- (2) Withdraw timebase unit Type 42, and apply the waveform from V8 anode to the Y1 plate of an oscilloscope Type 10 and the waveform from the junction of resistors R47 and R48 to the Y2 plate; *fig. 41* shows the points from which the oscillograms can be taken.
- (3) Adjustment of the DIVIDER control on the front panel of the timebase unit will alter the ratio between the top and bottom waveforms. The setting in AMES Type 21 Mk. 5 is that for a ratio of 4 : 1; this will give a repetition frequency of 125 c/s for the IFF transmitter, the radar repetition frequency being 500 c/s. *Fig 44* gives the waveforms to be expected.

**139.** If an oscilloscope is not available, the DIVIDER control may be set as follows:—

- (1) Turn DIVIDER fully clockwise: this will give a counting down ratio of 6 : 1.

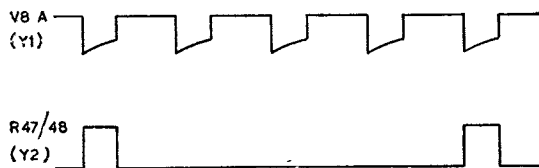

**Fig. 44.** Timebase unit Type 42 : divider control waveforms

- (2) Turn the control slowly counter-clockwise and observe the upper trace on indicating unit Type 123. The trace will be seen to pass through an unstable condition and then become steady again. The ratio will then be about 5 : 1.
- (3) Continue turning the control counter-clockwise until a second unstable condition is passed through, after which the trace becomes steady again; the ratio will then be correct.

**140.** Turn the EXPANSION BRIGHTNESS control (timebase unit Type 42) fully clockwise and adjust TRACE SEPARATION and Y SHIFT (indicating unit Type 123) until the traces lie above and below the range scale. It may first be necessary to turn the CRT slightly so that the traces are horizontal.

- (1) Operate the TIMEBASE WIDTH control (timebase unit Type 42) to obtain the correct number of calibration pips on the radar (lower) trace (i.e., 15 pips for 75 miles, 30 pips for 150 miles). The first pip corresponds to a range of 5 miles.
- (2) Use the X SHIFT and VELOCITY controls on indicating unit Type 123 to align the calibrator pips with the range scale. There are two velocity controls behind the front panel at the left-hand side of the chassis: VELOCITY COARSE is a two-position switch, and VELOCITY FINE a potentiometer.
- (3) Rotate the STROBE control (console 1) until the brightened portion of the trace on indicating unit Type 123 lies on a calibrator pip at about the centre of the timebase.
- (4) Adjust EXPANSION WIDTH (timebase unit Type 42) so that the width of the expanded (brightened) portion of the timebase occupies a range of three miles. An estimate of this distance can be made by comparing the width of the trace from the end of the brightened portion to the next calibration pip with the distance occupied by two miles of normal trace.
- (5) Adjust EXPANSION (timebase unit Type 42) so that the three mile strobe occupies one centimetre of trace. The appearance of the correctly adjusted strobe is shown in *fig. 45*.

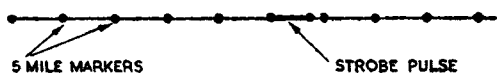

Fig. 45. Indicating unit Type 123: radar trace

- (6) Adjust BRIGHTNESS (indicating unit) to give the normal trace a suitable brilliance.
- (7) Adjust EXPANSION BRIGHTNESS so that the expanded portion is a little brighter than the normal trace.

#### Final adjustments—radar

141. The following final adjustments to the radar portion of the equipment should be made:—

- (1) Replace all units and control desks and close all doors. Recheck the current of the stabilizer valve in power unit Type 375 (*para. 125 (7)*).
- (2) Check focusing and calibration, and adjust brightness to the correct operating level. This should also be done after switching from L.P.O. to transmitter SYNC.

#### Final adjustments—IFF

142. The A-band IFF transmitter and receiver must be on when making these adjustments:—

- (1) Place the LOCK link (*fig. 41*) to the IFF position.
- (2) Switch off the CAL key (console 1).
- (3) Turn the control marked AK.98 RADAR on the front panel of console 1, amplifying unit Type 413, to give a noise level of 2mm on the lower trace of indicating unit Type 123.
- (4) Adjust BRIGHTNESS and FOCUS controls and check calibration.

#### Elevation scan display

143. Set the aerial by hand to an angle of tilt corresponding to a beam angle of  $-1$  deg. (*para. 46 to 52*).

- (1) Set the BLANKING switch (panel Type 509) to ELEV SCAN.
- (2) Monitor the current of the stabilizer valve in scanning unit Type 14 (meter switch position 9). Turn the ADJ STAB control until the meter reads 0.4mA.
- (3) Turn the SCAN LIMIT control fully clockwise.
- (4) The trace on indicating unit Type 114 of console 3 in the operations vehicle should be almost horizontal. Adjust the SET ZERO controls on the front panel of scanning unit Type 14 until the trace is horizontal. It may be necessary to adjust the position of the gridded mask so that the trace lies under the base grid line.
- (5) Tilt the aerial by hand to maximum tilt. Adjust the MAG OUT control on scanning unit Type 14 so that the trace coincides with the 20 deg. elevation line.
- (6) Repeat operations (4) and (5) until the settings are correct at maximum and minimum angles of tilt.
- (7) To check the setting-up, tilt the aerial to a beam angle of 6 deg. (i.e., increase the aerial tilt by 7 deg. from minimum). The 60 mile marker pip should cross the 35,000 ft. height line.
- (8) Adjust SCAN LIMIT until the Y scan is blacked out beyond 10cm.

#### Elevation strobing facilities

144. After the aerial tilt has been adjusted and checked at 6 deg., the elevation strobe (*para. 52*) may be set to give a brightening of the trace at any desired angle of elevation. First, set the aerial to the required angle and then set the adjustable arm on the elevation gearbox (*fig. 14*) until the contacts of switch unit Type 902 close. The strobe may be brought into use by switching on the AZ IND key on the control desk of console 3.

## OPERATION OF THE PLAN-POSITION AZIMUTH TURNING GEAR

#### Running up

145. Control unit Type 443 in radio vehicle Type 467 must first be switched on. After this, the equipment in the aerial vehicle may be switched on.

#### Operations vehicle

146. The mains supply to the control unit comes from the distribution board via a switch CONTROL UNIT CIRCUIT 1. This switch should be placed in the ON position.

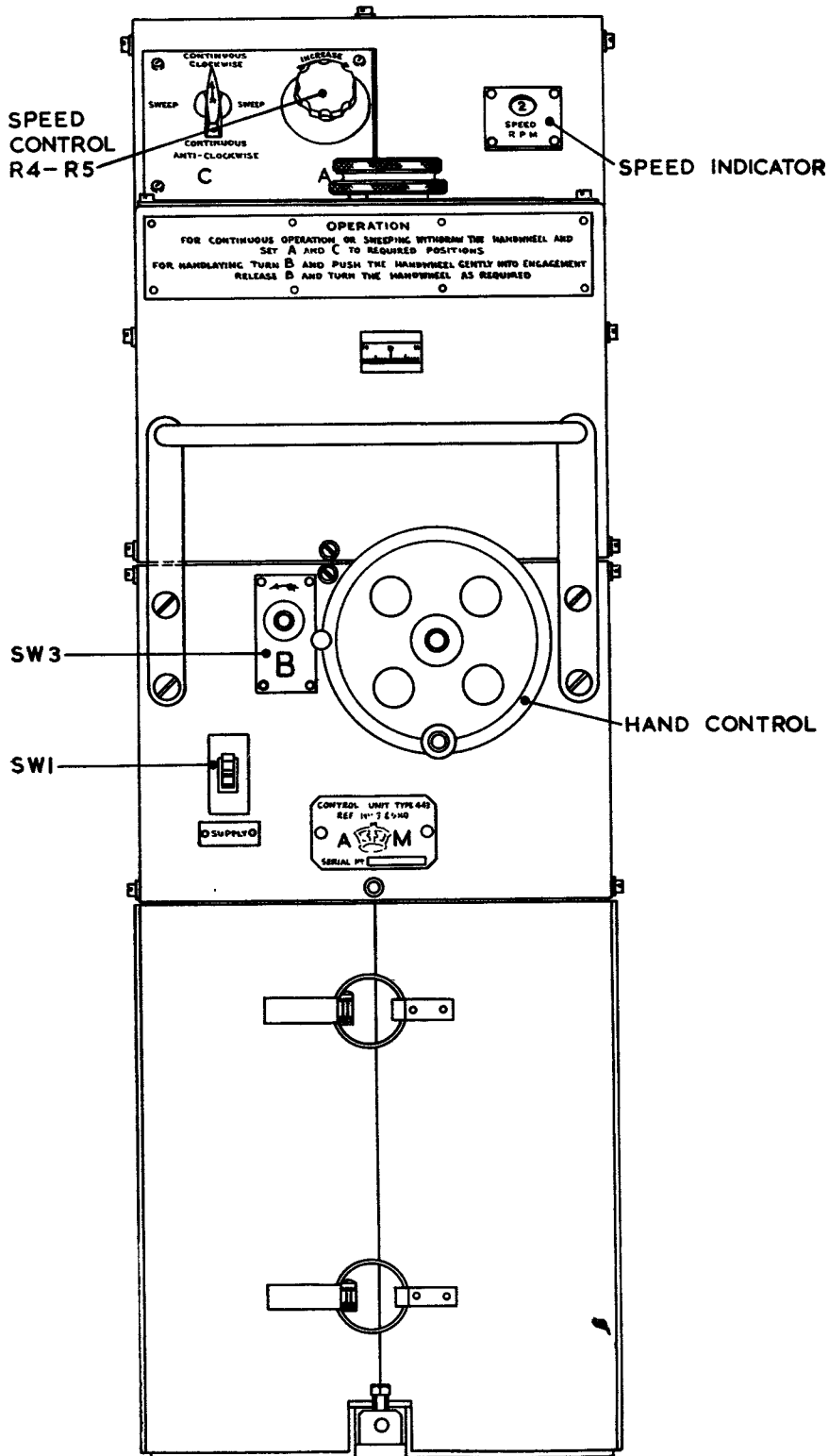

Fig. 47. Control unit Type 443 : front panel

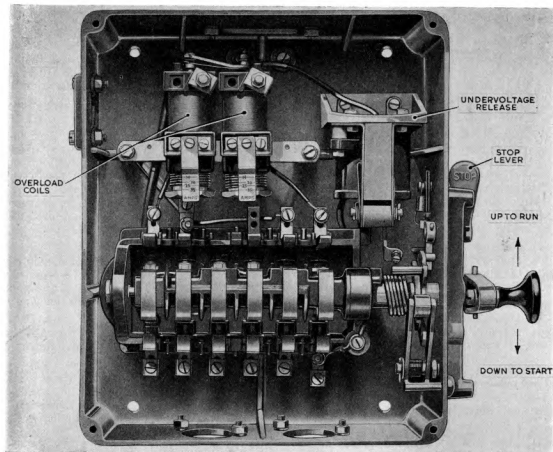

Fig. 46. Starter unit Type 13 (R.V.462C)

Turn on the control unit supply switch which is located on the front panel.

#### Aerial vehicle

**147.** First check that the aerial is free to rotate; this can be done quickly by turning the hand wheel inside the cabin.

- (1) Press and hold down the handle at the side of starter unit Type 13 (fig. 46). The turning gear AC motor will start to turn and will quickly gather speed. As soon as the normal running speed is reached, lift the handle smartly to the RUN position and release it. Unless the upward movement is completed quickly, the contactors will not close, the motor will lose speed, and it will be necessary to repeat the starting drill.

- (2) Close the cabin door to complete the door interlock circuit.
- (3) Press the push button on the outside of the container to complete the contactor circuit.
- (4) After a few seconds, the aerial turntable should start to turn and then lock in position ready for control from the operations vehicle.

#### Control of aerial rotation

##### Hand laying

**148.** Push in the hand wheel on the front panel of the control unit while turning knob B counter-clockwise. Turning knob B interrupts the supply to the pilot motor. Turn the hand wheel in either direction as required and the aerial will rotate in synchronism.

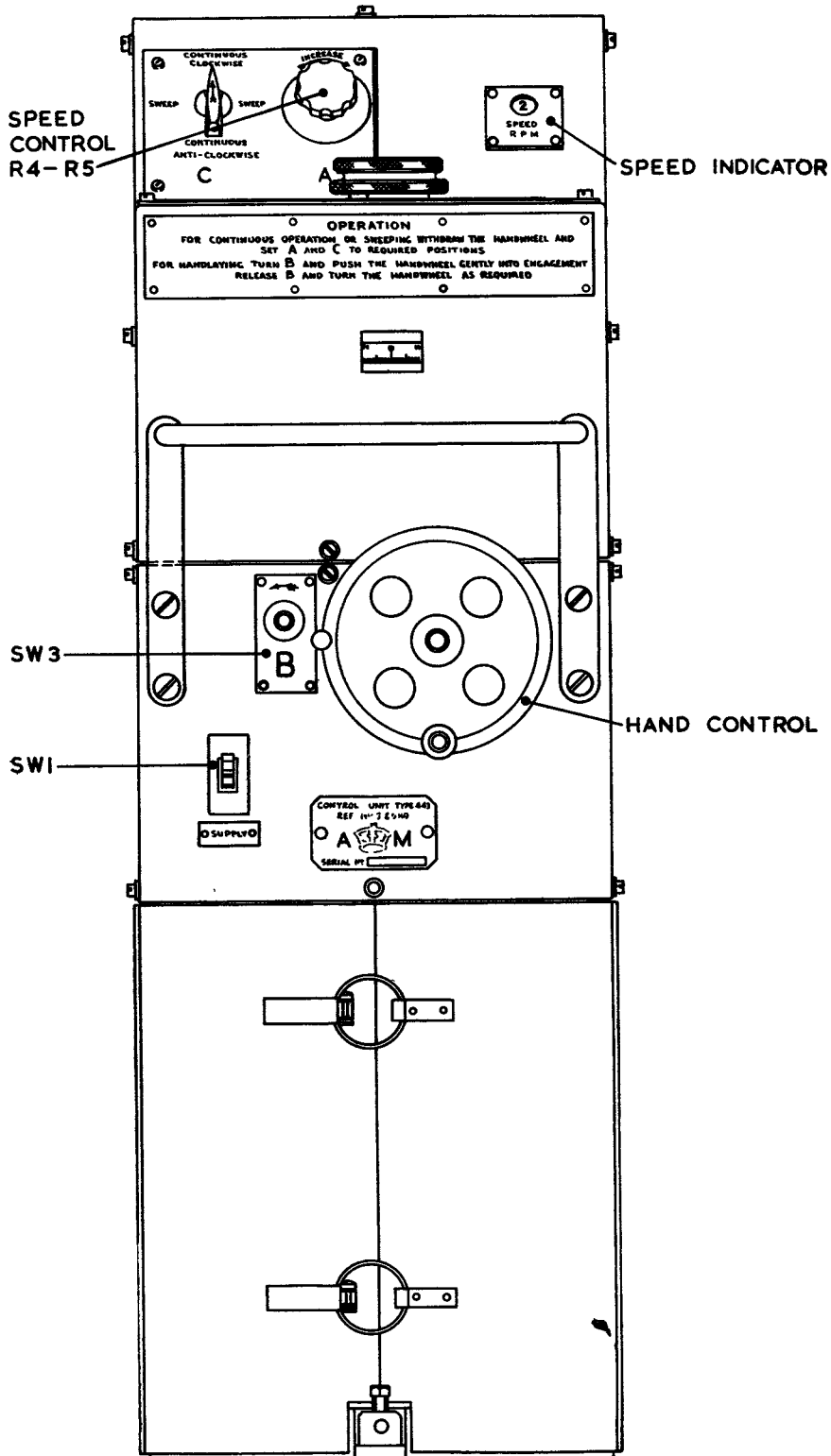

Fig. 47. Control unit Type 443 : front panel

**Continuous rotation**

**149.** Withdraw the hand wheel and turn switch C either to the CONTINUOUS CLOCKWISE or CONTINUOUS ANTI-CLOCKWISE position. Turn the speed control knob to give the required r.p.m. as shown on the ivorine scale. The maximum speed is 6 r.p.m.

**Sweeping a selected arc**

**150.** When this facility is employed, the aerial is made to rotate at high speed (6 r.p.m.) over an unwanted sector and slowly over a selected arc from 5 to 300 deg. The action is entirely automatic and is achieved as follows:—

The relevant control knobs are located on the flat portion on top of the control unit. Turn the outer knob to the number of degrees through which the sweep is to be slow. Turn the inner knob to the mean bearing of the selected arc. For example:— with the inner knob set to 300 deg. and the outer knob set to 50 deg., the aerial will rotate quickly from 325 deg. through 360 deg. to 275 deg. and will then slow down for the next 50 deg. until 325 deg. is reached again.

**Adjustment of the PPI trace azimuth**

**151.** This applies to consoles 1 and 2 when they have been set up electrically and at other times when required. The method is as follows:—

- (1) Connect Jones socket B to the console (panel Type 520) and the timebase will rotate in synchronism with the aerial.
- (2) Depress the AZIM IND key on the control desk.
- (3) As the aerial rotates, the aerial position indicator switch attached to the

aerial framework will close, causing a brightening of the PPI trace. The switch can be made to operate at any required bearing by bolting it down in the appropriate position on the turntable.

**152.** The bearing at which the brightening of the trace occurs can be found during installation by using a magnetic compass. Any subsequent deviation between the PPI trace and the aerial position may at once be checked. Any deviation may be corrected in the following manner:—

- (1) Note the number of degrees error, and stop the aerial.
- (2) Remove Jones socket B from panel Type 520.
- (3) Remove the mumetal box cover and rotate the timebase deflector coils by means of the manual drive knob until the deviation has been corrected.
- (4) Replace Jones socket B, and replace the mumetal box cover.

**153.** If the trace jumps a degree or so when replacing Jones socket B (*para. 152 (4)*), proceed as follows:—

- (1) Switch off the console.
- (2) Loosen the clamp of the selsyn drive coupling (*fig. 31*). The coupling screw is visible through the bottom hole of the left-hand side of the coil rotating mechanism.
- (3) Switch on the console and again adjust the position of the trace.
- (4) Switch off, and tighten the coupling.
- (5) Replace the metal box cover.

**OPERATION OF THE HEIGHT-FINDER AZIMUTH TURNING GEAR****Running up**

**154.** Switch on control unit Type 442 in the operations vehicle before running up the turning gear apparatus in the aerial vehicle.

**Operations vehicle**

**155.** Close the switch on the distribution board marked CONTROL UNIT CIRCUIT 3. A light will appear behind the control unit scale (*fig. 26*). If the light is to the right, push in the knobs, and it should appear to

the left. Turn the knobs on the control unit Type 442 until the bearing line on the scale is at 0 deg.

**Aerial vehicle**

**156.** Check that the aerial is free to rotate by attempting to turn the hand wheel inside the cabin.

- (1) Press and hold down the handle at the side of starter unit Type 13. The AC motor will start to turn and quickly

gather speed. As soon as normal running speed is reached, lift the handle smartly to the RUN position and release it. Unless the upward movement of the handle is done quickly, the contactors will not close, the motor will lose speed and the starting drill must be repeated.

- (2) Close the cabin door to complete the door interlock circuit.
- (3) Press the push button on the outside of the container to complete the contactor circuit.
- (4) After a few seconds, the aerial should start to turn and then lock into position ready for control from the operations vehicle.

### **Control of rotation**

#### *Continuous rotation*

**157.** Turn the inner knob on the front of the control unit very slowly in either direction (operations vehicle). The aerial should turn in the direction in which the knob is turned at a speed (in r.p.m.) indicated by the figure illuminated on the scale. The maximum possible speed is 6 r.p.m. in either direction.

#### *Hand control*

**158.** Turn the aerial speed down to zero and withdraw the knobs. The light will then appear at the right-hand side of the scale. The sector through which the cabin will rotate is now governed by the angular movement of the selsyn motor rotor coil. This sector can be read off in degrees on the scale. Thus, to turn 70 deg., set the bearing scale to read 70 deg. by means of the front panel knobs: (the outer knob is more highly geared than the inner though both fulfil the same functions). The container will then turn through 70 deg. in its own time. With practice, a high standard of hand-laying accuracy and speed of operation can be achieved.

#### **Adjustment of line of light azimuth (azimuth of AMES Type 13)**

**159.** The procedure is almost identical with that detailed in para. 151 and 152. In this case, however, Jones socket C is involved (not B) and in place of a brightened trace, an indicator lamp lights at the moment when the aerial switch closes. The relevant control desk key is labelled A.P.I. (aerial position indicator).

# Chapter 4

## SERVICING

### LIST OF CONTENTS

	Para.		Para.
<b>INTRODUCTION</b>		<b>INFORMATION ON TR.3561</b>	
General .....	1	General .....	82
<b>TEST EQUIPMENT</b>		The magnetron .....	84
Test set Type 288 .....	6	Retaping the waveguide .....	85
General description .....	7	The local oscillator .....	86
Using the test set .....	11	Monitor Type 53 .....	88
Servicing .....	13	Waveform inspection .....	90
Monitor Type 33 .....	14	Crystals used in TR.3561 .....	91
Testing transmitter Type T.3117 .....	18	Care of the magnet .....	95
Pulse-width measurement .....	19	<b>POWER SUPPLIES</b>	
Wavemeter Type W.1649 .....	20	The 500-cycle power supply .....	96
Use as a wavemeter .....	23	Maintenance .....	99
Use as a signal source .....	24	Current consumption .....	101
Servicing notes .....	25	The power board .....	102
Output tester Type 65 .....	26	The carbon-pile regulator .....	104
Resistance unit Type 289 .....	30	Adjustment of the carbon-pile regulator .....	107
Signal generator Type 106 .....	32	<b>SIGNAL AND SYNC. PULSE CHAINS</b>	
Brief circuit description .....	35	General .....	108
Preparation for use .....	36	The radar signal chain .....	109
Test set Type 172A .....	37	The sync. pulse chain .....	112
Brief circuit description .....	40	<b>IFF SYSTEM</b>	
Using the test set .....	41	A-band IFF .....	114
Servicing notes .....	42	Mixer unit Type 13 .....	117
Test set Type 223A .....	43	The selector switch .....	121
Using the test set .....	45	Lock switch .....	122
Fault tracing .....	46	Receivers Type R.3118 .....	123
Test set Type 102 .....	47	Transmitter Type T.3117 .....	125
Using the test set .....	50	G-band IFF .....	129
Oscilloscope Type 10 .....	51	Transmitter Type T.3638 .....	130
Using the oscilloscope .....	53	Switch unit Type 271 .....	131
Signal generator Type 53 .....	55	Amplifier Type A.3175 .....	132
Signal generator Type 108 .....	57	Band switching .....	133
Operating instructions .....	59	<b>THE DISPLAY CONSOLES</b>	
Wavemeter Type G82A .....	62	General .....	134
Measuring TR.3561 local oscillator frequency .....	63	Cabling .....	135
Measuring the magnetron frequency .....	64	R.V.467 Jones sockets .....	137
Tuning the receiver .....	65	Current and voltage checks .....	138
<b>AERIAL SYSTEMS</b>		The console control desk .....	141
Plan-position aerial turning gear .....	66	Narrow bandwidth key .....	142
Brief outline of the system .....	67	Short-time constant key .....	143
The contactor unit .....	70	Low-pass filter key .....	144
Starter unit Type 13 .....	71	Calibrator key .....	145
Height-finder azimuth turning gear .....	72	Range key .....	148
Brief description of the system .....	73	IF gain control .....	150
Aerial tilting circuit .....	77	Narrow bandwidth tune control .....	151
Production of the elevation scan waveform .....	79		

R E S T R I C T E D

## INTRODUCTION

### GENERAL

1. The aims of this chapter are:—

(1) To detail the methods of operating all the items of test equipment supplied with AMES Type 21, Mk. 5.

(2) To assist the user in servicing the test equipment.

(3) To assist in recognizing and rectifying performance defects and equipment failure.

2. In order to assist in identifying the various items of test equipment, illustrations have been included where practicable.

3. It has not been possible to detail a list of symptoms and probable remedies for fault-finding. Instead, essential circuits have been drawn to facilitate tracing the circuit stage by stage through the whole equipment without reference to detailed circuit diagrams, the aim being to give a clear picture of the functions of these circuits.

4. For example, in fig. 35 the path of the received signal is traced from the aerial to its presentation on the cathode-ray tube. Whenever a lead passes from one unit to another the relevant connections to terminal

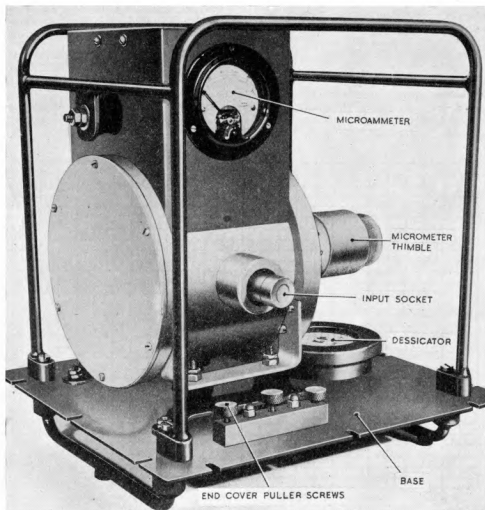

Fig. 1. Test set Type 288 : general view

## LIST OF CONTENTS—contd.

	Para.		Para.
Remote strobe control . . . . .	152	<b>MAINS SUPPLIES</b>	
Azimuth indicator key . . . . .	153	General . . . . .	162
Indicator lamp circuit . . . . .	155	<b>SLIP RING CONNECTIONS</b>	
Aerial position indicator key . . . . .	156	General . . . . .	165
Mains supply switch . . . . .	157	<b>ANCILLARY EQUIPMENT</b>	
Inter-console cables . . . . .	158	G.P.O. rectifier unit . . . . .	167
The console air blower system . . . . .	159	Vehicle battery charging unit . . . . .	171

## LIST OF ILLUSTRATIONS

	Fig.		Fig.
Test set Type 288 : general view . . . . .	1	500c/s supply starter unit : circuit . . . . .	34
Test set Type 288 : frequency correction curve . . . . .	2	Plan-position signal chain . . . . .	35
Magnetron frequency spectra . . . . .	3	Height-finder signal chain . . . . .	36
Monitor Type 33 : front view . . . . .	4	Sync. pulse chain . . . . .	37
Monitor Type 33 : side view . . . . .	5	IFF A-band signal chain . . . . .	38
Waveforms from transmitter Type T.3117 . . . . .	6	Transmitter Type T.3117 : control circuit . . . . .	39
Wavemeter Type W.1649 . . . . .	7	G-band IFF : schematic diagram . . . . .	40
Output tester Type 65 : general view . . . . .	8	Display consoles : layout of panels . . . . .	41
Resistance unit Type 289 . . . . .	9	R.V.467 : location of Jones sockets . . . . .	42
Signal generator Type 106 : front panel . . . . .	10	Narrow bandwidth key . . . . .	43
Signal generator Type 106 : block diagram . . . . .	11	Short-time constant key . . . . .	44
Test set Type 172A : front panel . . . . .	12	Low-pass filter key . . . . .	45
Test set Type 172A : block diagram . . . . .	13	Calibrator key . . . . .	46
Test set Type 223A : front panel . . . . .	14	Range key (consoles 1 and 2) . . . . .	47
Wavemeter Type W.1633 : rear view . . . . .	15	Range key (console 3) . . . . .	48
Test set Type 102 . . . . .	16	IF gain control . . . . .	49
Comparator unit : exploded view . . . . .	17	Narrow bandwidth tune control . . . . .	50
Oscilloscope Type 10 : front view . . . . .	18	Remote strobe control . . . . .	51
Oscilloscope Type 10 : rear view of chassis . . . . .	19	Azimuth indicator key (consoles 1 and 2) . . . . .	52
Signal generator Type 53 : front panel . . . . .	20	Azimuth indicator key (console 3) : use for strobe facility . . . . .	53
Signal generator Type 108 : front panel . . . . .	21	Indicator lamp : circuit . . . . .	54
Wavemeter Type G82A : front panel . . . . .	22	Aerial position indicator key . . . . .	55
Plan-position aerial turning gear : block diagram . . . . .	23	Mains supply switch . . . . .	56
Turning gears Type 52 and 53 : contactor unit circuit . . . . .	24	Inter-console cabling . . . . .	57
Starter Type 13 : circuit . . . . .	25	Blower motor circuit . . . . .	58
Height-finder azimuth turning gear : block diagram . . . . .	26	230V AC mains distribution in R.V.461C . . . . .	59
Operation of relay unit Type 171 . . . . .	27	230V AC mains distribution in R.V.462C . . . . .	60
Aerial tilting gear : circuit . . . . .	28	230V AC power supply circuits . . . . .	61
Production of elevation scan : schematic diagram . . . . .	29	G.P.O. rectifier unit Type 58 . . . . .	62
TR.3561 : block diagram . . . . .	30	Valve bases . . . . .	63
Monitor Type 53 and receiving unit Type 177 : block diagram . . . . .	31	TR.3561 waveforms . . . . .	64
180V 500c/s power supply : wiring of power board . . . . .	32	Display console waveforms . . . . .	65A, B, and C
TR.3561 : power supply distribution . . . . .	33	Frequency-wavelength conversion curve . . . . .	66A and B
		AMES Type 21 Mk. 5 interconnections . . . . .	67

blocks, plugs and sockets, etc., have been shown and in this way the possibility of mistaking pin connections is minimized. Fig. 1 and 2 of Chap. 2 provide a key to plug and socket numbering.

5. In fig. 67, is shown an interconnection diagram for AMES Type 21, Mk. 5 with references to the more detailed figures for R.V.461C and R.V.462C.

## TEST EQUIPMENT

### Test set Type 288 (fig. 1)

6. Test set Type 288 is a cavity resonator wavemeter in the frequency range 2,940 to 3,060 Mc/s. It has a high "Q" factor of 30,000 to 40,000 and a frequency accuracy of 0.1 per cent. When the calibration curve correction is applied, readings with 0.01 per cent. accuracy are obtained, corresponding to  $\pm 0.3$  Mc/s in 3,000. A frequency correction curve, which is shown in fig. 2, is supplied with each instrument.

### General description

7. The piston plate of the cavity is attached to a micrometer screw, the thimble of which is engraved with 10 major divisions each representing 1 Mc/s. Each major division has five sub-divisions of 200 kc/s each.

The main scale is engraved in 10 Mc/s divisions, the frequency being shown every 50 Mc/s between 3,150 and 2,940 Mc/s.

8. The input is applied to the socket below the microammeter by means of a special cable (connector Type 1205). The output loop incorporates a crystal detector which is connected to a 0—100 microammeter, shunted by a 4  $\mu$ F condenser.

9. The instrument is carried in a special container in which it should always be kept when not in use. Before placing it in the case the micrometer should be set to 3150 Mc/s (that is, fully screwed in) or the thimble may foul the edge of the container.

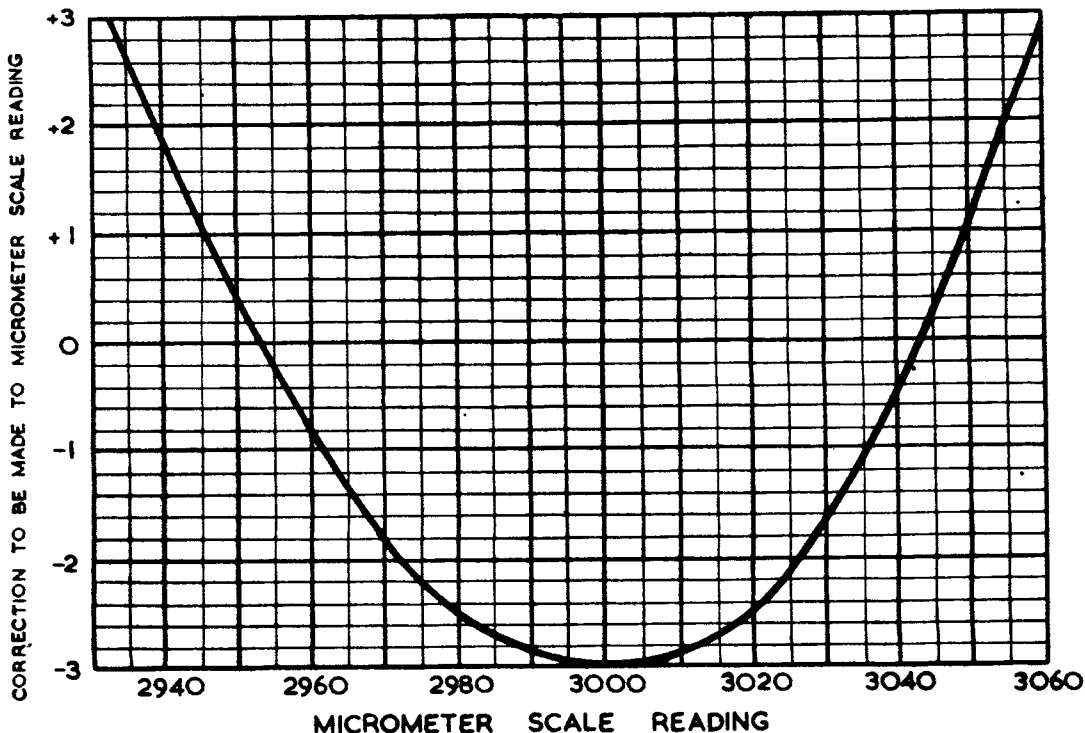

Fig. 2. Test set Type 288 : frequency correction curve

10. Three knurled screws carried on a bar inside the test set are for removal of the micrometer end cover. This is carried out only at calibration centres.

#### Using the test set

11. Arrange for a loose coupling between test probe and RF source so that only a small portion of the RF voltage is fed into the cavity. Turn the micrometer and note the point at which the meter reads maximum. The micrometer scale reading should be corrected using the frequency correction curve to give the frequency of the source.

12. When taking a magnetron frequency spectrum, plot meter deflection in microamps against frequency at suitable intervals for five Mc/s either side of resonance. Fig. 3 shows typical curves which are obtained. Ideally, there should be one sharp peak but, as shown in fig. 3A, small peaks occur either side of the main one. If asymmetric curves or large secondary peaks are obtained as in B and C, either the performance of the magnetron is unsatisfactory or there is frequency pulling due to a mismatch in the system.

#### Servicing

13. Replacement of the crystal (CV103) should be the only servicing necessary. No attempt should be made to interfere with the cavity or input and output loops. Access to the crystal is obtained by removing the cover over the micrometer. To do this take out seven of the nine screws (the two at the rear of the instrument need not be removed). The crystal holder may then be removed by unscrewing the large knurled collar on top of the cavity.

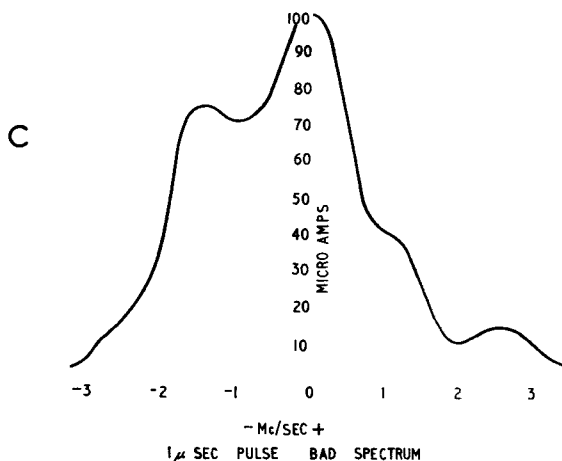
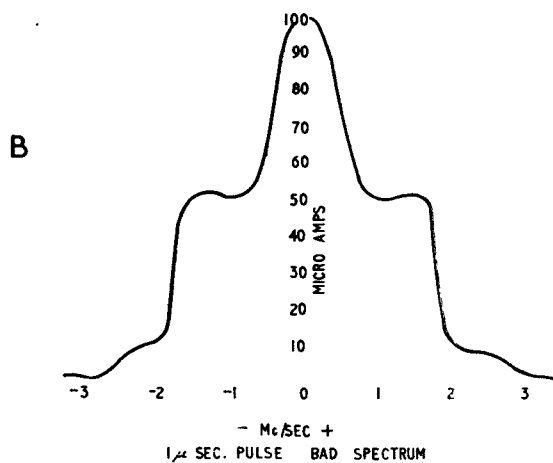
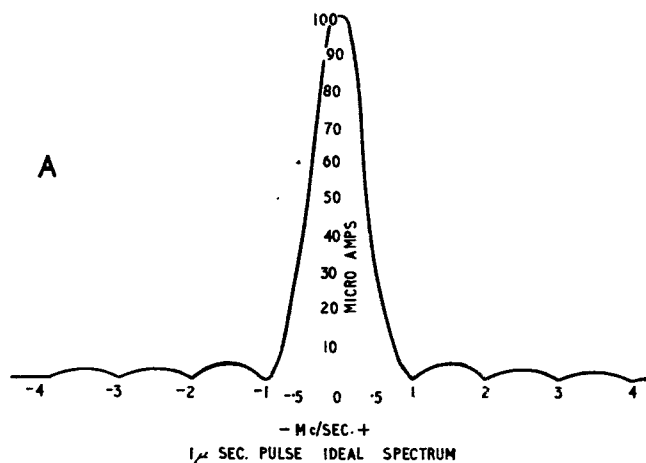

Fig. 3. Magnetron frequency spectra

**Monitor Type 33 (fig. 4)**

**14.** This monitor is used principally to test the operation of the A-band IFF transmitter Type T.3117 but it can be employed as an ordinary oscilloscope.

**15.** Before using the instrument check that it is set for 230 volts working by removing the unit from its case and examining the mains input tagboard which is located on the right side (fig. 5). One of the black screws should be placed in the +220 volts socket and the other in the +10 volts socket for 230 volts working.

**16.** Connect the mains cable to a suitable supply point and switch on. The red pilot lamp should light.

**17.** Connect one of the co-axial cables between SYNC on the modulator front panel and SYNC on the monitor. The other cable is for monitoring DC or RF pulses as described below.

**Testing transmitter Type T.3117**

**18.** Of the eight monitoring points shown in fig. 6 the first six are obtained by connecting the second co-axial cable between

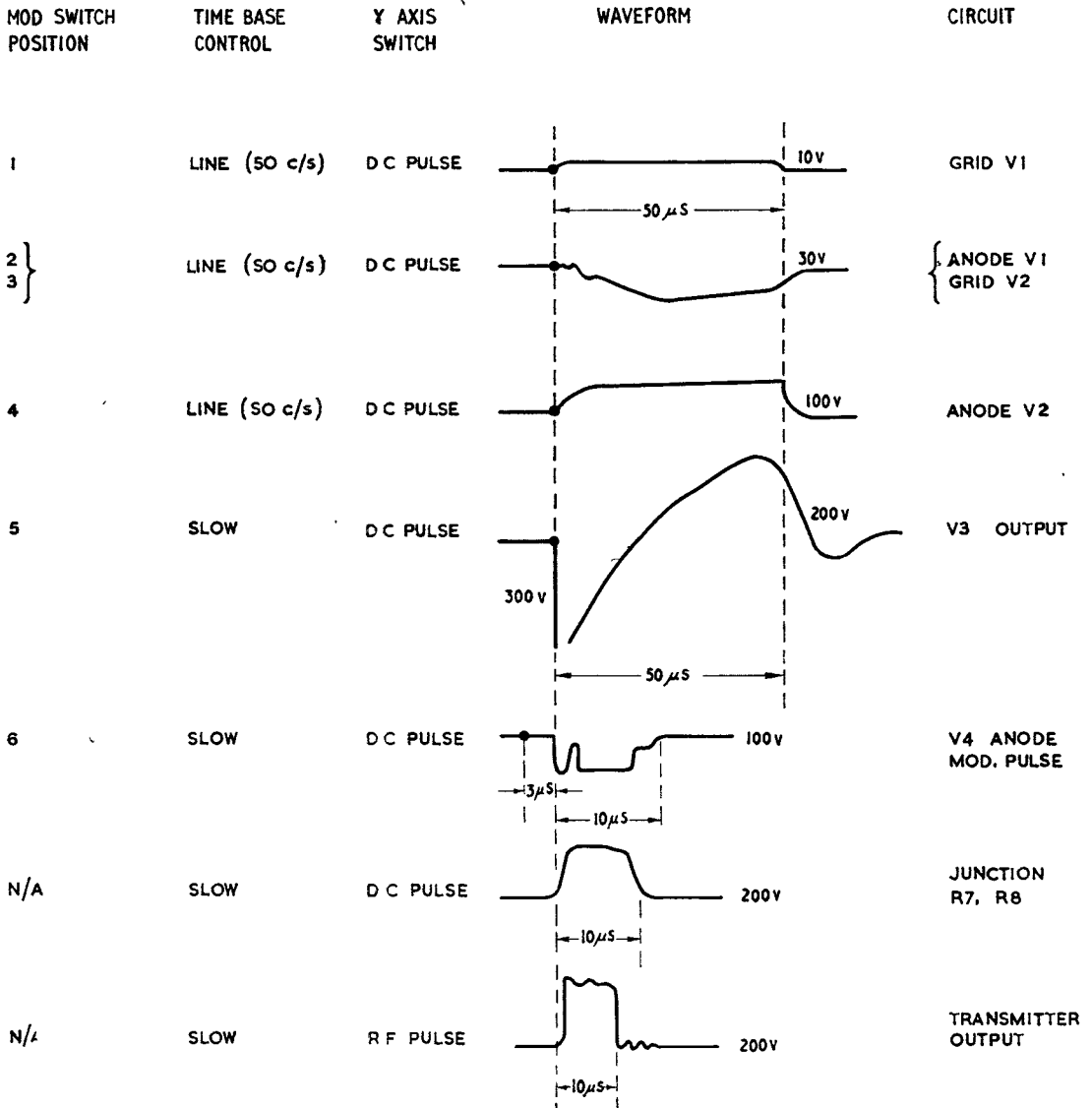

**Fig. 6. Waveforms from transmitter Type T.3117**

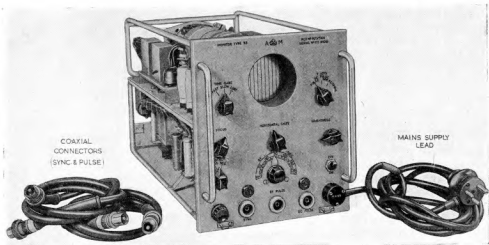

Fig. 4. Monitor Type 33 : front view

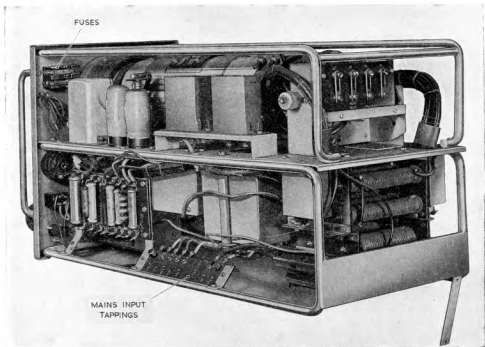

Fig. 5. Monitor Type 33 : side view

the DC PULSE socket of the monitor and MONITOR POSITION socket of the transmitter and switching to the appropriate position of the six-position switch on the front panel of the modulator section of the transmitter. The seventh waveform is obtained by connecting the signal cable between DC PULSE on the monitor and POSITIVE LOCKING SIGNAL OUT on the transmitter and the eighth by connecting the RF PULSE socket on both units.

#### Pulse-width measurement

19. To measure the width of the transmitter pulse proceed as follows:—

- (1) Turn the Y-AXIS switch fully clockwise to the 500 KC/S TIMING position.
- (2) Set the timebase to FAST or SLOW.

#### Note . . .

*Duration of the fast timebase is 16  $\mu$ s.*

*Duration of the slow timebase is 32  $\mu$ s.*

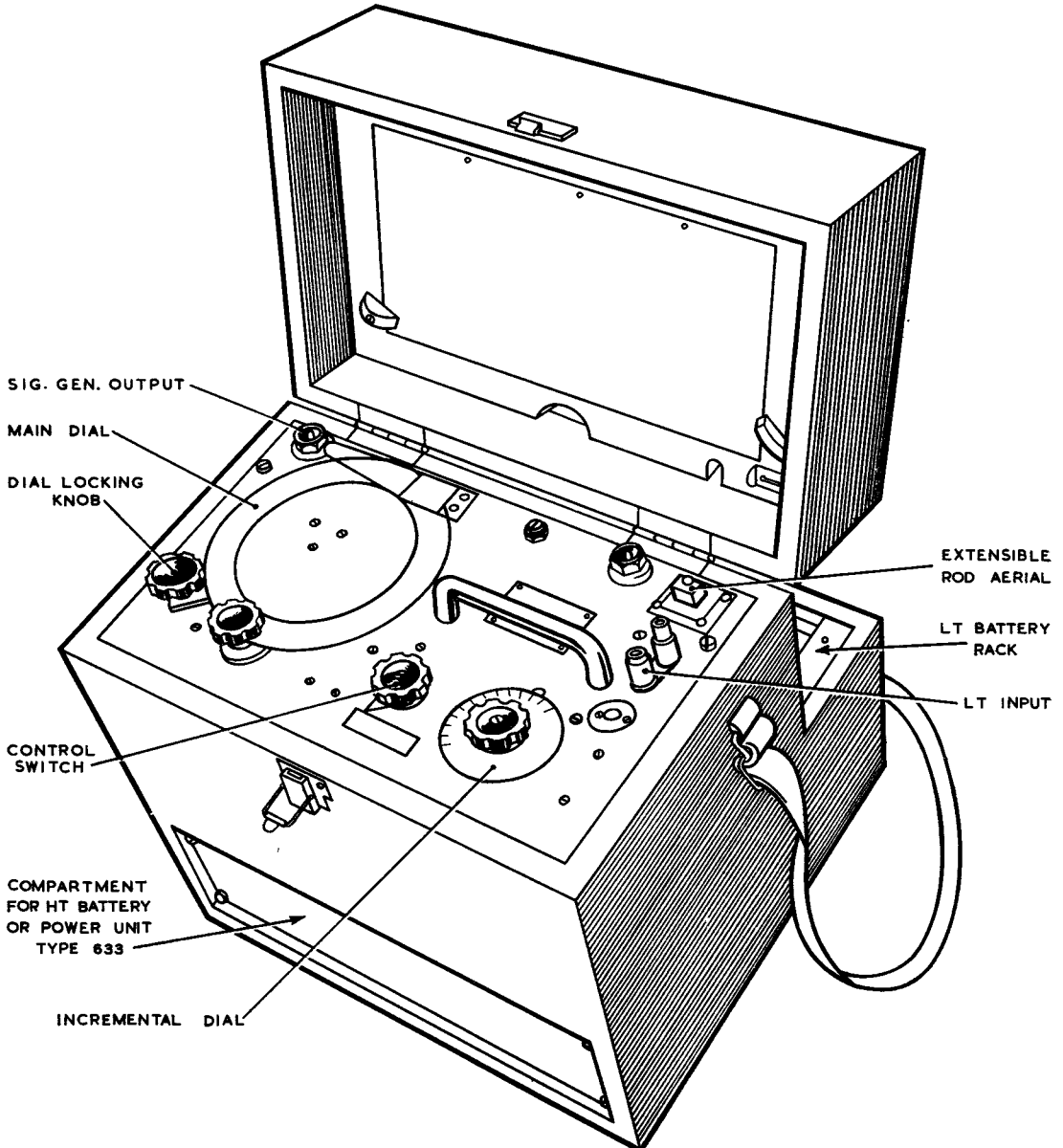

Fig. 7. Wavemeter Type W.1649

- (3) Connect the RF PULSE socket of the transmitter to the RF PULSE socket of the monitor.
- (4) Mark the CRT mask to show 2  $\mu$ s intervals (one such interval corresponds to one cycle of the 500 kc/s sine wave).
- (5) Turn the Y-AXIS switch to RF PULSE.
- (6) Adjust HORIZONTAL SHIFT until the start of the pulse coincides with a 2  $\mu$ s mark.
- (7) Assess the width of the pulse by reference to other calibration marks. It should be 8 to 10  $\mu$ s.
- (4) Set the control switch to XTAL.
- (5) Rotate the main tuning dial until the heterodyne beat note nearest to the setting previously noted is heard.
- (6) Set the control switch to ON.
- (7) Tune the signal to maximum by means of the incremental dial only.
- (8) The frequency of the transmitter is given by the addition or subtraction of the two dial readings.

#### Wavemeter Type W.1649 (fig. 7)

**20.** This is a heterodyne wavemeter which may be operated from batteries (120-volt HT, 6-volt LT) or from the mains (by employing power unit Type 633).

**21.** As a wavemeter the frequency coverage is 155 to 255 Mc/s; as a signal generator it is 140 to 240 Mc/s. The heterodyne is to produce a 15 Mc/s IF and the local oscillator becomes the signal source.

**22.** Tappings on the mains transformer allow of operation from any of the following supplies:—

- (1) 80 volts 400/2000 c/s
- (2) 110 volts 60 c/s
- (3) 115 volts 400/2000 c/s
- (4) 180 volts 500 c/s
- (5) 230 volts 50 or 400 c/s

For setting-up of the IFF equipment as described below the tappings should be set for 230 volts 50 c/s operation.

#### Use as a wavemeter

**23.** To check a transmitter frequency proceed thus:—

- (1) Set the control switch to ON and the incremental dial to zero.
- (2) Inject the transmitter signal into the wavemeter via either the rod aerial or a probe connected to the input plug.
- (3) Rotate the main tuning dial until the p.r.f. note is audible in the headphones and note the dial reading on the inner scale.

#### Use as a signal source

**24.** The frequency of the output, which may be fed direct or via attenuator unit Type 68, is given in this case by the reading on the outer scale. To check calibration, the inner scale of crystal check points may be used, bearing in mind that the oscillator valve operates at 15 Mc/s *below* the frequency indicated on the outer scale. Maximum output is of the order of 10 decibels down on 0.1 volt (roughly 0.03V) when feeding into a 46-ohm termination. The attenuator reduces the output to 100  $\mu$ V.

#### Servicing notes

**25.** The following points will be useful.

- (1) *Current consumption* should be 13mA  $\pm$  3mA.
- (2) *Battery voltage.* The on-load volts of the batteries should not be below 5.6 volts LT and 100 volts HT.
- (3) *Power unit.* If hum is present when operating on 500 or 1,500 cycle supplies, adjust the pre-set potentiometer in the power unit until the hum is a minimum.
- (4) *Crystal oscillator.* If the crystal fails to oscillate, first check power supplies; then the tuned circuit in the anode should be adjusted as follows:—  
Screw out the iron core of the inductance until a dull "plop" is heard in the phones. This indicates that the valve is oscillating. Screw the core in two further turns from the point at which the oscillation began.
- (5) *Oscillator valve replacement.* A matched valve (CV6) is packed with the instrument as a spare and is screwed into a spare valve holder behind the front panel until required. Certain valves of this type may not oscillate above 230 Mc/s.

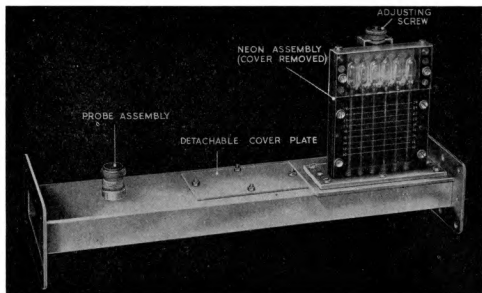

Fig. 8. Output tester Type 65 : general view

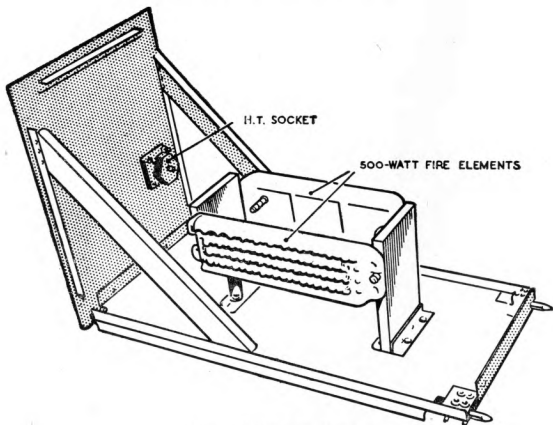

Fig. 9. Resistance unit Type 289

**Output tester Type 65 (fig. 8)**

**26.** Output tester Type 65 is a high-power standing-wave indicator and power measuring device for the band 9.8 to 10.2 cm. It consists of a short length of 3 in.  $\times$  1 in. waveguide with six neon tubes (CV360), of special design, arranged along the 3 in. face and backed by a graduated scale as shown in fig. 8. In practice the output tester forms a section of the waveguide run and is located immediately above the transmitter box.

**27.** The electro-magnetic fields in the waveguide ionize the neon and a pink glow is produced whose height up each tube is proportional to the field strength at that point. As the six tubes are arranged to cover about half a wavelength, the ratio of the maximum to the minimum scale reading gives the standing-wave ratio. The scale

graduations are such that the product of maximum and minimum readings gives the peak power output in kilowatts.

**28.** Provision is made for withdrawing the neon tubes from the waveguide when measurements are not required. Their life, which is only a few hundred hours running time, may thus be prolonged to several thousand operational hours. The metal protective can should also be used to cover the neon tubes when the instrument is not in use.

**29.** It should be noted that the length of the column of gas excited varies approximately as the square root of the pulse length and so, as the instrument has been calibrated on wide pulse, the indicated power on narrow pulse will be less than the actual output.

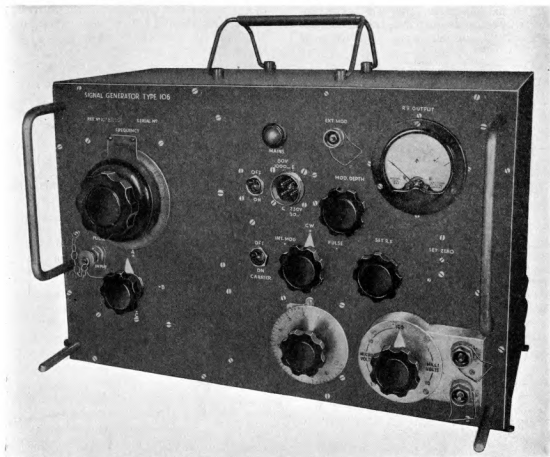

Fig. 10. Signal generator Type 106: front panel

**Resistance unit Type 289 (fig. 9)**

30. Resistance unit Type 289 is a dummy load which may be used to absorb the EHT output from the modulator when checking the TR.3561. For example, if a short circuit in the transmitter is suspected, the EHT may be disconnected from the transmitter and fed to the dummy load and if the fault lies in the transmitter the modulator should function normally.

31. The unit consists of two 500-ohm fire elements connected in series. It must, however, be modified for use with AMES Type 21 Mk. 5 so that the elements are in parallel; the impedance then matches the modulator output impedance. Check that the elements are connected in parallel before use.

**Signal generator Type 106 (fig. 10)**

32. Signal generator Type 106 has a continuously variable output between 1 microvolt and 100 millivolts in the frequency range

6.1 to 52 Mc/s. There are four frequency bands (1) 6.1 to 10.5 Mc/s, (2) 10.4 to 18.3 Mc/s, (3) 18.3 to 32 Mc/s, (4) 29.5 to 52 Mc/s. Reference has to be made to calibration charts giving frequencies corresponding to the dial readings. The output impedance of the signal generator is 70 or 100 ohms.

33. The instrument may be modulated in three ways.

- (1) Internally by 1,000 c/s square wave.
- (2) Externally by pulses of not less than 40 volts amplitude.
- (3) Externally by low frequency of at least 15 volts amplitude.

34. It has a built-in power unit which operates from either 80 volts 1,500 c/s or 220/240 volts 50 c/s supplies. Pins 1 and 2 of the power unit plug are for the 80 volts input, pins 1 and 4 for the 230 volts input, while pin 3 is earthed.

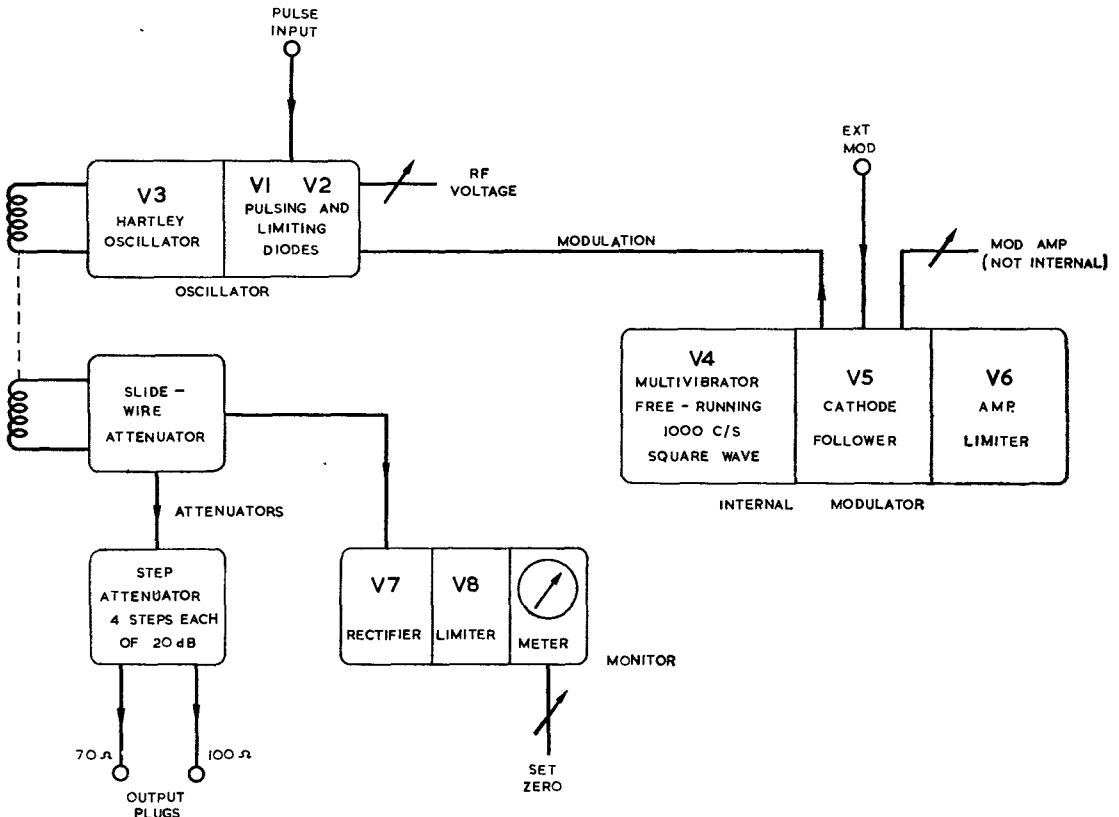

Fig. 11. Signal generator Type 106: block diagram

### Brief circuit description

**35.** In the block diagram of fig. 11, V3 is a Hartley oscillator with switched coils for band changing. Oscillation amplitude is controlled by V1 and V2, pulsing and limiting diodes. The output is controlled by a slide wire potentiometer and a step attenuator which has four steps of 20dB each. With a pulse input to V3 the oscillator is allowed to function only for the duration of pulses. V4, a free running 1,000 c/s multivibrator, provides the internal modulation, feeding a square wave via V5, a cathode-follower, and V6 which acts as an amplitude limiter. V7 rectifies part of the output and this gives an indication of output on a 0-50 microammeter. The meter is shunted by a 25K variable resistor in series with a diode, V8, to permit zero adjustment.

### Preparation for use

**36.** The following procedure will be necessary before using the signal generator.

- (1) Check that the signal generator is correctly wired for 230-volt 50 c/s operation.
- (2) Check that the connector is wired to pins 1 and 4 of the power input plug.
- (3) Connect to a suitable mains supply and switch on.
- (4) Leave for half an hour to warm up.
- (5) Put the CARRIER switch to OFF.
- (6) Adjust SET ZERO, a screwdriver pre-set control, so that the meter reads zero.
- (7) Return CARRIER switch to ON.
- (8) Set to the appropriate band and set the frequency dial with reference to the calibration charts.
- (9) Set the modulation and output selector switches as required. (For the majority of applications these will be for internal modulation or CW).
- (10) Set RF carrier level by the control SET RF. until the meter needle is on the X1 mark on the scale.

### Note . . .

*The carrier level will require resetting from time to time and in particular when frequency is changed.*

- (11) Connect the signal generator output to the equipment under test. The 70-ohm socket will invariably be used.

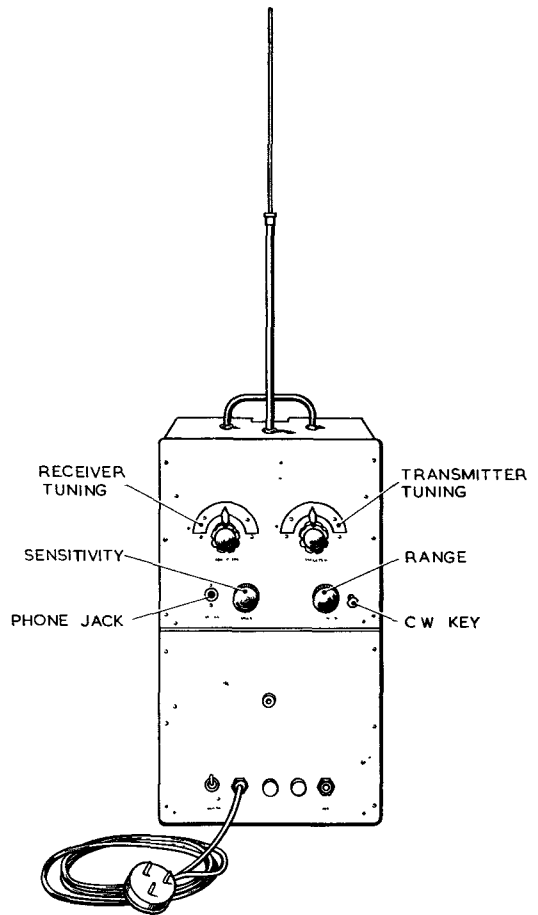

**Fig. 12. Test set Type 172A : front panel**

### Test set Type 172A (fig. 12)

**37.** The test set Type 172A was developed for testing the performance and alignment of IFF Mk. 3 ground installations. It provides an artificial IFF response at any desired bearing and range, the range being normally from 20-56 miles. Since the frequency coverage is approximately 155 to 187 Mc/s its use is confined to A-band equipment.

**38.** When in use the test set is placed 100 to 200 ft. from the A-band aerials (on R.V.461C) at any convenient bearing. The desired range and operational frequency are then set up and, when the IFF Mk. 3A installation is operating, a response will be shown on the display system when the IFF aerials are directed towards the test set.

39. Use may be made of this arrangement as follows :—

- (1) To set up the A-band IFF equipment.
- (2) To test the frequency response.
- (3) To check the azimuth discrimination of the aerial array.

**Brief circuit description**

40. In the block diagram of fig. 13, V1, V2 and V3 form a super-regenerative receiver, the output from V3 being a series of positive pulses at the p.r.f. of the transmitter under test. Each positive pulse triggers the transitron V4 which generates a square pulse of variable width at its anode. The square wave is differentiated and the negative peak of the differentiated waveform, coinciding with the delayed edge of the square wave, is used to trigger a transmitting valve V6 after inversion by V5. Thus a delayed pulse is transmitted to the IFF aerial. The amount of delay can be controlled by the RANGE potentiometer.

**Using the test set**

41. The following procedure should be adopted when using the instrument.

- (1) Remove the power unit and check that it is set for 230-volt, 50 c/s operation.
- (2) Replace the power unit and connect to a suitable point.
- (3) Switch on the MAINS switch and allow a few seconds before switching on the HT.
- (4) Extend the telescopic aerial.

- (5) Plug a pair of high-impedance headphones into the jack marked PHONES.
- (6) Rotate SENSITIVITY control till a "plop" is heard in the phones and a "frying" noise ceases.
- (7) Turn back SENSITIVITY about  $\frac{1}{4}$  turn.
- (8) Slowly rotate the RX TUNING control until the p.r.f. of the IFF transmitter is heard.
- (9) Adjust SENSITIVITY and tune the receiver to the IFF transmitter frequency to give maximum volume.

**Note . . .**

*If the SENSITIVITY control is turned up too far the test set will radiate a series of unlocked pulses.*

- (10) Set the transmitter section to the working frequency using wavemeter Type W.1649.

**Servicing notes**

42. The following checks will be of use in servicing :—

V1 anode	66 volts DC
V2 cathode	70 volts DC
V4 screen	180 volts DC
V4 anode	155 volts DC
V5 anode	20 volts DC
V6 cathode	60 volts DC
HT positive	190 volts DC
Current consumption	34 milliamps
Current consumption with CW key pressed	69 milliamps

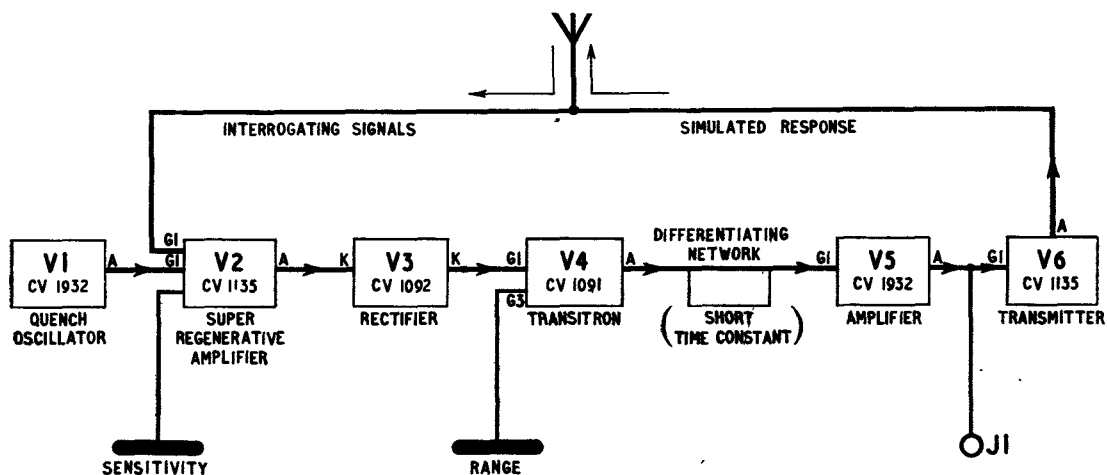

Fig. 13. Test set Type 172A : block diagram

**Test set Type 223A (fig. 14)**

**43.** This wavemeter consists of two parts, indicating unit Type 230 and wavemeter Type W.1633. The indicating unit is a universal instrument in that it can be employed with a number of wavemeters covering different wavebands. It incorporates a DC amplifier, peak voltmeter and magic eye tuning indicator. The wavemeter section, which covers the 8–11 cm. band with an accuracy  $\pm 0.2$  per cent. embodies a tuned circuit and crystal detector. It may be used to check CW, or pulse radiation, provided the p.r.f. is greater than 100 c/s.

**44.** A universal power supply is incorporated which will operate from any of the following supplies—110 or 230 volts 50 c/s; 230 volts 400 c/s; 80 volts 800–2,400 c/s; 115 volts 400–2,400 c/s; 180 volts 500 c/s. The 4-pin socket on the front panel is wired for both 80 and 230-volt operation, pins 1 and 4 for 230 volts and 1 and 2 for 80 volts. Pin 3 is earthed. Of the two cables supplied with AMES Type 21 Mk. 5 the one having a 3-pin plug at one end is used.

**Using the test set**

**45.** After checking the mains supply setting of the test set proceed as follows:—

- (1) Connect to a suitable supply point.
- (2) Switch on.
- (3) Turn SENSITIVITY control to MAX., that is fully clockwise.
- (4) Turn SET IND. so that the shadow angle on the magic eye is approximately 30 deg.
- (5) Place the pick-up lead close to the equipment under test.
- (6) Rotate the tuning dial until the shadow on the magic eye begins to close.

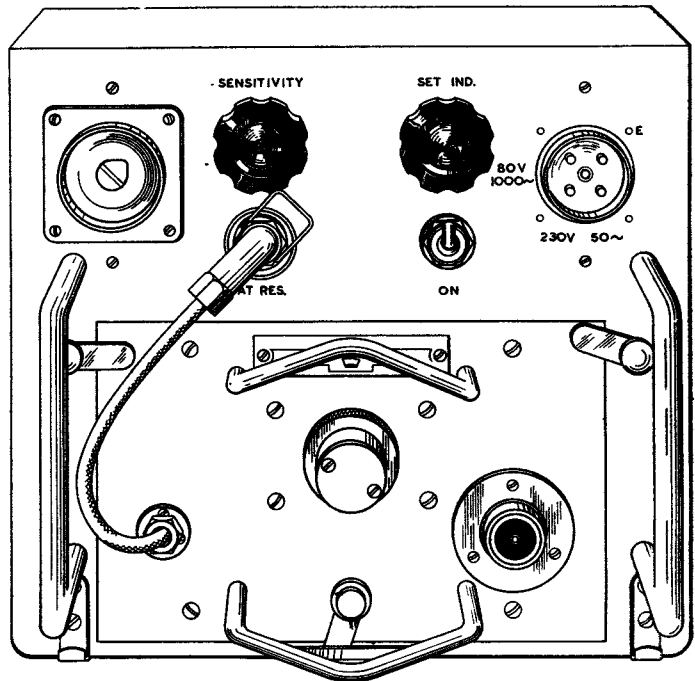

**Fig. 14. Test set Type 223A : front panel**

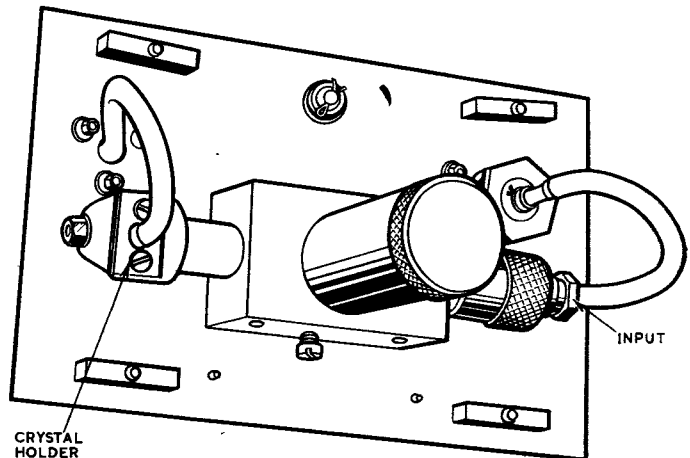

**Fig. 15. Wavemeter Type W.1633 : rear view**

- (7) Reduce SENSITIVITY to prevent over-loading and tune to resonance.
- (8) Determine the wavelength by referring to the calibration chart.

**Fault tracing**

**46.** The following common faults and suggested remedies may be helpful.

the knob being released at any point beyond 0.6 on the dial, returns it to the 0.6 position. This prevents the comparator being left to dissipate a high power for a long period.

#### Using the test set

**50.** The mains tapping link, access to which is gained by removing the small plate on the front panel of the test set, should be set so that socket C is linked to the 220/240 volts socket. Fig. 16 shows the position of the link and of the fuses, the upper of which is spare. When this check has been made proceed as follows:—

- (1) Connect the mains lead 3-pin plug to a suitable supply point.
- (2) Switch on. (A red pilot lamp will light.)
- (3) Set the RECURRENCE knob to the 50 c/s position.
- (4) Loosen the two screws of the plate covering the pre-set AMPLITUDE control and set the control to the mid-way position.
- (5) Plug the comparator unit (fig. 17) into the transmitter Type T.3117 aerial socket.
- (6) Connect the cable shown by the side of the instrument in fig. 16 between the

OUTPUT socket and the lock input of the modulator.

- (7) Switch on transmitter Type T.3117. The lamp on the left of the white line, seen through the vizard of the comparator lamp cylinder, will glow.
- (8) Turn the WATTMETER control until the brilliance of the second lamp, on the right-hand side of the white line, matches that of the first.
- (9) Note the WATTMETER dial reading.
- (10) The approximate peak RF power can be obtained as follows:—

$$\text{Peak power (watts)} = \frac{\text{Dial reading} \times 10^6}{\text{p.r.f.} \times \text{pulse width } (\mu\text{s})}$$

#### Oscilloscope Type 10 (fig. 18)

**51.** The oscilloscope Type 10 is a double-beam oscilloscope intended primarily for examination and comparison of circuit waveforms. It has a recurrent linear time-base operating over the range 5 to 250,000 c/s and handles frequencies up to about 5 Mc/s. It operates from AC mains supplies of 110 and 200 to 250 volts at 40 to 100 c/s with a power consumption of 120 watts.

**52.** The following specification figures may be useful:—

#### (1) CRT

Y-plate sensitivity	....	....	3.1 volts/mm. DC
X-plate sensitivity	....	....	2.25 volts/mm. DC
Calibration voltage	....	....	50 volts peak-to-peak
	(Measured at terminal C)		
Deflector coil sensitivity	....	....	2 mm/mA RMS
Maximum coil current	....	....	60mA RMS
Y2 attenuator	..	....	Maximum voltage applicable 400 volts RMS
			Frequency range 30 – 15,000 c/s.
			Reduction ratios X1, X2, X4, X8

#### (2) Amplifiers

Stages	Switch position	Gain	Frequency range	Sensitivity
1	Y1 Y2	28	10–100,000 c/s	43mV/mm. RMS
2	2Y1	900	10–100,000 c/s	1.3mV/mm. RMS
2	2HFY1	106	10 c/s–2 Mc/s	10mV/mm. RMS

(1) If the wavemeter is insensitive, replace the crystal. Fig. 15 shows the position of the crystal holder. To measure the back-to-front resistance ratio there is no need to remove the crystal. The ratio measured on the 100,000 ohms scale of the Avometer should be greater than 10 : 1.

(2) If SET IND. has no effect, the following voltage checks may be useful. V5 cathode should be 90-110 volts. The anode volts of V2 and V4 should vary over the same range as V5 cathode as SET IND. is rotated. If V2 is not following, check V1 and V2. If V4 is not following, check V3, C5, C4, R10 and C3.

(3) If the magic eye is not working, check the supply voltages including heater volts and connections. The HT on C7 should be 360/400 volts and on C6, 320/360 volts.

#### Test set Type 102 (fig. 16)

47. Test set Type 102 may be used to supply a locking pulse for, and provide a rough check on, the IFF A-band transmitter Type T.3117. A circuit diagram is affixed to the lid of the test set.

48. The method of checking transmitter output is by comparing the light intensity of a lamp illuminated by the RF output with that of one whose wattage can be read off on a scale. A supply of carbon lamps is provided in the compartment attached to the lid of the test set and when these are exhausted the instrument should be returned for re-calibration.

49. To protect the comparator lamp a spring device is fitted to the spindle of the wattage control potentiometer which, on

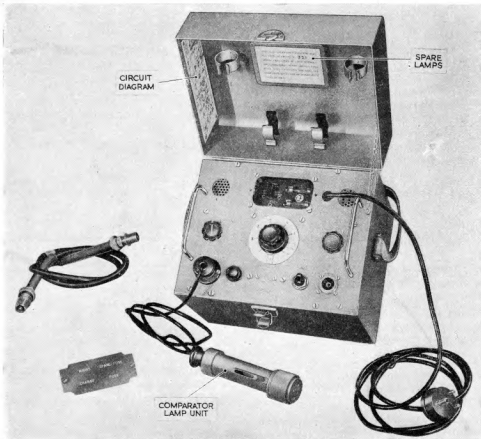

Fig. 16. Test set Type 102

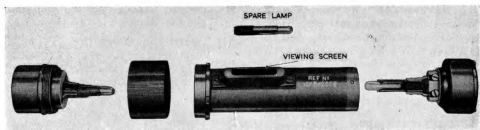

Fig. 17. Comparator unit : exploded view

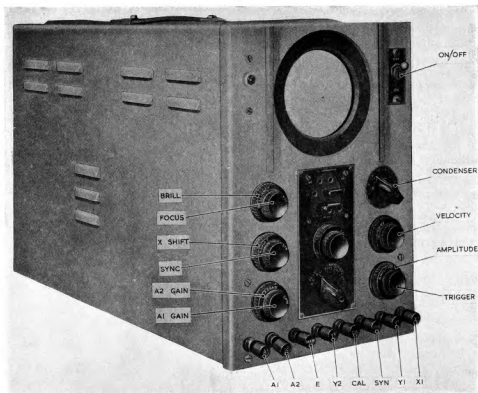

Fig. 18. Oscilloscope Type 10 : front view

#### Using the oscilloscope

53. The following points should be noted.

(1) The mains voltage selector link (fig. 19) should be placed between socket C and the 220-230 volts socket.

(2) Fig. 19 also shows the normal position of the Y1 link.

(3) In position 1 of the timebase switch the XI terminal is connected directly to the

XI plate of the CRT. This provides for application of an external deflecting voltage. With the switch in any other position, the timebase deflecting voltage is present at the XI terminal.

(4) By applying the voltage (nominally 50V peak-to-peak) at the terminal marked CAL to the Y-plate, the face of the CRT may be roughly calibrated and the voltage amplitudes of waveforms determined.

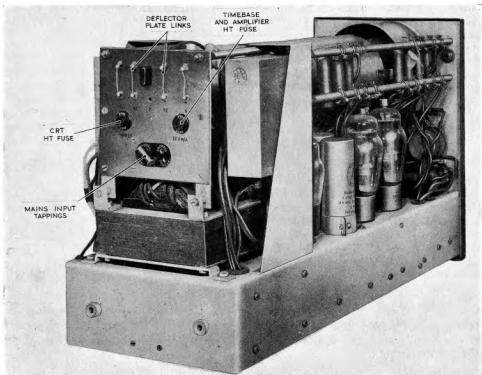

Fig. 19. Oscilloscope Type 10 : rear view of chassis

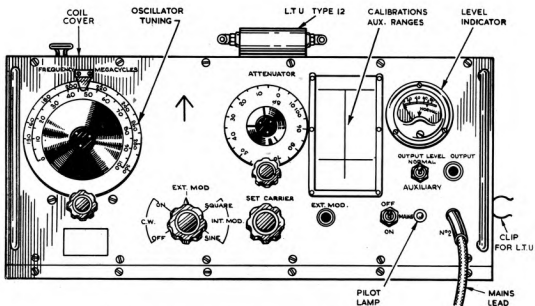

Fig. 20. Signal generator Type 53 : front panel

54. Normally when waveforms in AMES Type 21 Mk. 5 are being examined the time-base switch should be set to position 4 and the amplifier switch to AC. The waveform should be applied between Y1 and E terminals with SYNC connected to Y1. A table of oscilloscope points together with waveforms to be expected is given in fig. 65.

#### Signal generator Type 53 (fig. 20)

55. Signal generator Type 53 has three ranges 10–18 Mc/s, 33–58 Mc/s, 150–300 Mc/s which cover the radar IF of 45 Mc/s, the IFF intermediate frequency of 11 Mc/s and IFF radio frequencies of 157–209 Mc/s. The three range coils are located under a sliding cover on top of the signal generator. The instrument has a continuously variable output from 0.1  $\mu$ v to 0.2 volt which may be modulated internally by a 1,000 c/s sine or square wave or externally by pulses or square wave. Its output impedance is 45 or 80 ohms.

56. It operates from 200–250 volts, 40–100 c/s supply and has a power consumption of 40 watts.

#### Signal generator Type 108 (fig. 21)

57. This instrument, which is used to measure the sensitivity of the receiver in TR.3561, requires a 180-volt 500 c/s supply.

It operates in the range 9.8 to 10.2 cm. giving maximum output of 23 millivolts. The output may be square wave modulated at 500 c/s.

58. The oscillator is a CV35 klystron whose output is picked up by a loop and passed to a bolometer measuring device and thence to a piston attenuator which is calibrated in decibels from 0 to 100. The frequency is varied by one of the klystron tuning plungers which is controlled by the knob marked TUNING. All the other plungers are set in manufacture and if the klystron is removed, the signal generator will require recalibration.

#### Operating instructions

59. The instrument should be prepared for use as follows:—

- (1) Connect the power supply lead to a suitable point.
- (2) Put the mains supply switch in the FIL position.
- (3) Wait one minute to allow the valves to warm up.
- (4) Switch to HT position.
- (5) Adjust GRID and REFLECTOR controls for maximum steady glow of the bolometer filament.

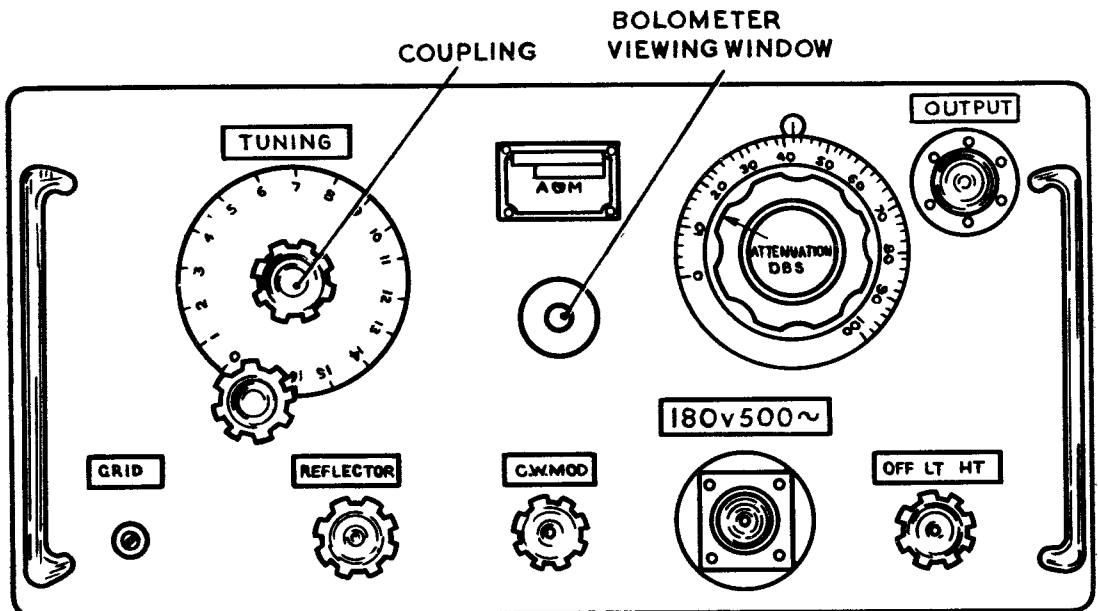

Fig. 21. Signal generator Type 108: front panel

- (6) Turn the modulator to MOD or CW as required.
- (7) Adjust the COUPLING control until the bolometer filament is only just visible. The input to the calibrated attenuator is now standardized.

60. The signal is fed into the waveguide from the TR.3561 via the socket which is part of output tester Type 65. Where the output tester is not fitted it will be necessary to remove the rectangular plate which is affixed to the substitute section of waveguide. Impedance matching unit Type 264, which contains a socket to accommodate the signal generator output lead, takes the place of the plate.

61. Day to day checks on receiver performances can be kept by determining the output required from the signal generator to produce a given deflection (say 1 cm.) on the monitor CRT. This provides a rough check on the soft rhumbatrons and head amplifier sensitivity.

### Wavemeter Type G82A (fig. 22)

62. Wavemeter Type G82A is a sensitive direct-reading instrument for measuring continuous wave and pulsed high frequencies in the wavelength range 9.5 to 10.5 cm. It may also be used as a signal generator in the same range giving approximately square pulses 10  $\mu$ s wide at 20  $\mu$ s intervals.

#### Measuring TR.3561 local oscillator frequency

63. The following procedure is recommended.

- (1) Check that the crystal current meter is showing a deflection, indicating that the local oscillator is oscillating.
- (2) Switch off the transmitter.
- (3) Remove the lead from the output plug of the local oscillator on the receiver panel.
- (4) Connect the local oscillator output to the plug marked CAL on the wavemeter.
- (5) Set the wavemeter switch to W/M.
- (6) Using the coarse drive, turn the wavemeter control till the magic eye blinks.

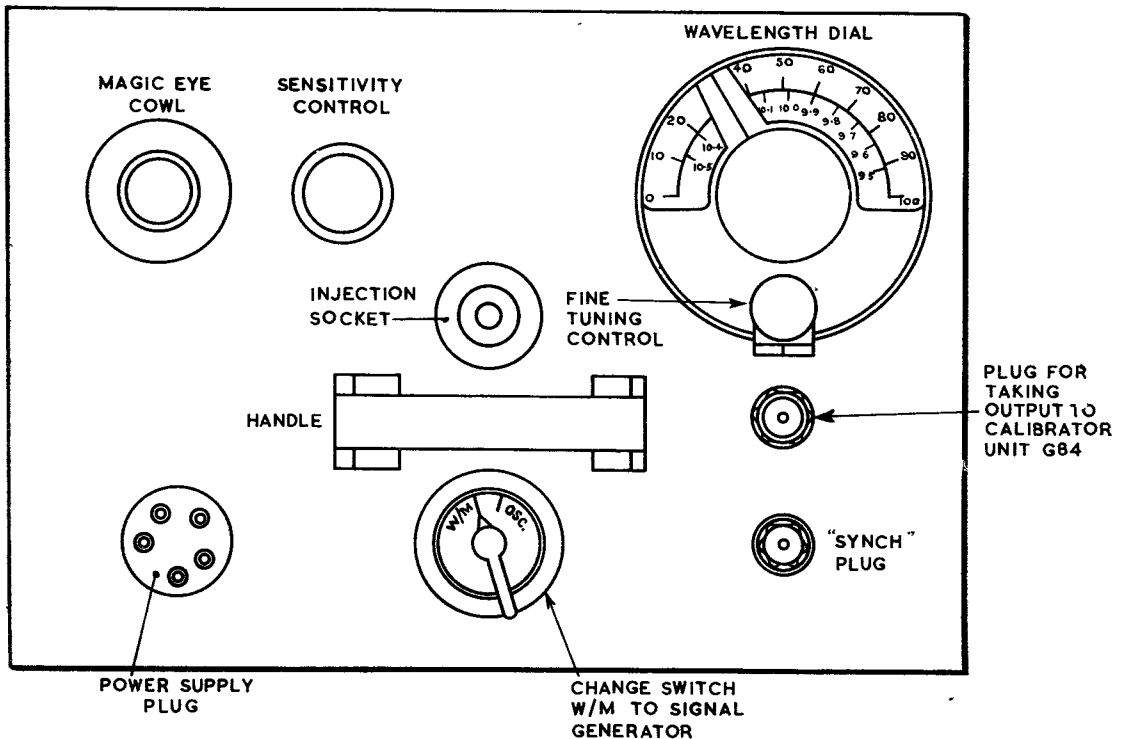

Fig. 22. Wavemeter Type G82A : front panel

- (7) Set the SENSITIVITY control to a suitable position.
- (8) Using the fine tuning control, find the two positions, very close together, where the magic eye is closed.
- (9) The wavelength of the local oscillator is midway between the two closed positions. Obtain a reading of frequency from the conversion curve at fig. 66.

#### *Measuring the magnetron frequency*

**64.** The magnetron frequency is determined as follows:—

- (1) Check that the transmitter is oscillating by the indication on the radiation meter. The wavemeter will pick up stray radiation.
- (2) Switch to w/m position.
- (3) Set SENSITIVITY at maximum.
- (4) Turn the tuning control until the magic eye blinks. This time there is only one closed position, the double blink being a characteristic of CW radiation.
- (5) Set SENSITIVITY to a convenient level.

#### **Note . . .**

*The indication can probably be improved by varying the insertion of the capacitance plunger.*

- (6) Tune slowly through the magic eye indication and note the point of maximum closure.
- (7) Read off the magnetron frequency with reference to the calibration curve.

#### *Tuning the receiver*

**65.** The receiver may be tuned up on a permanent echo but it may be more satisfactory to tune it using the wavemeter Type G82A as a signal generator. The following procedure should be followed:—

- (1) Determine the transmitter frequency as in para. 64.
- (2) Set the local oscillator frequency to be 45 Mc/s above or below the transmitter frequency.
- (3) Set the wavemeter back on the transmitter frequency, and switch off the transmitter.
- (4) Set the tuning screw on the receiver crystal box until it is about half way along its range of movement.
- (5) Connect the 500  $\mu\text{c}$  crystal current meter to read 2nd detector current.
- (6) Set noise level by means of the receiver gain control to read about 50  $\mu\text{c}$ .
- (7) Connect the wavemeter SYNC plug to the monitoring point second from the left on the modulator panel.
- (8) Switch the wavemeter G82A to osc.
- (9) Vary the depth of insertion of the lead from the aerial into the crystal holder on the mixer unit until the meter reading is a maximum.
- (10) Adjust the tuning screw for maximum second detector current.
- (11) Lock all controls on the crystal holder.
- (12) The local oscillator may be tuned finally on the wavemeter pulses which will be displayed on the screen.

## **AERIAL SYSTEMS**

### **PLAN-POSITION AERIAL TURNING GEAR**

**66.** The setting-up of aerial turning gear Type 52 has been described in Chap. 3, para. 145 to 153. The following paragraphs outline the system and describe the action of the contactor and starter systems with more detail.

#### **Brief outline of the system (fig. 23)**

**67.** The selsyn motor in control unit Type 443 provides the drive for the aerial turning motors. When the selsyn is turned, a voltage is applied via a similar motor in the aerial cabin to the input of the torque

amplifier. The output from this amplifier provides the field supply for a DC generator which is driven at constant speed by an AC motor. The generator output excites the driving motor which turns the cabin and in so doing resets the control selsyn rotor so that there is only sufficient input to the torque amplifier to enable the control selsyn to keep in step.

**68.** A repeater selsyn motor is also geared to the turntable and its stator coils are connected to two similar motors, one in each indicating unit Type 115. These two motors

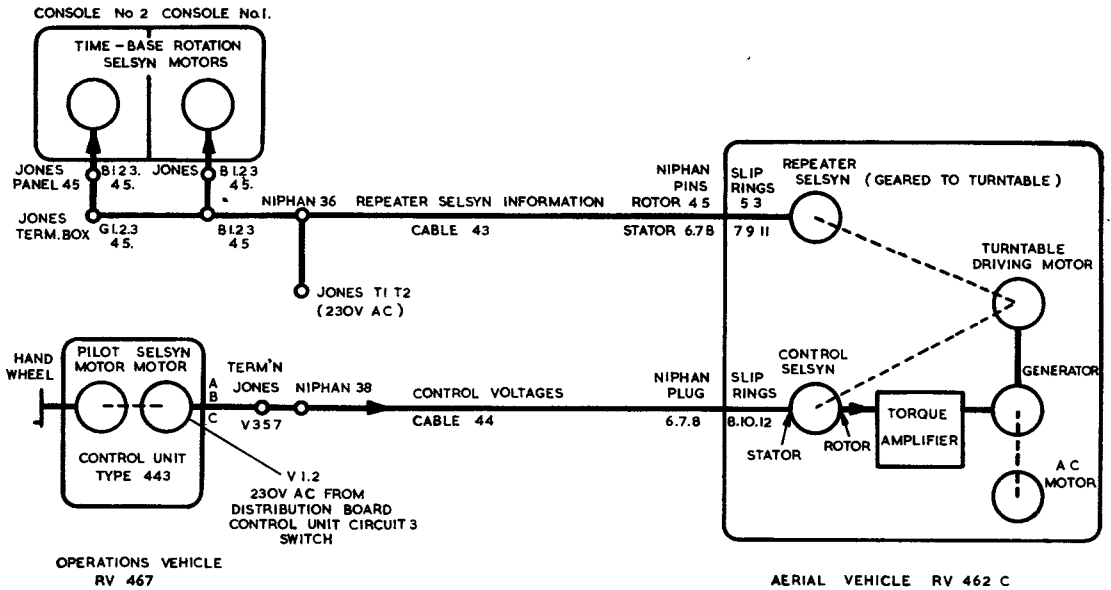

Fig. 23. Plan-position aerial turning gear : block diagram

rotate the timebase coils. Thus the timebase is made to rotate in step with the aerial.

69. A hand wheel is provided on the control selsyn to enable the operator to control the aerial over small arcs. A small pilot motor may be used for power drive clockwise or counter-clockwise at speeds up to 6 r.p.m. Also fitted to control unit Type 443 is an arc sweeping device whereby the aerial can be rotated slowly over a desired arc and quickly over the remainder.

**The contactor unit**

70. Fig. 24 shows the action of the circuit which cannot be completed unless the cabin door is shut, making the door interlock switch. With the starter switch in the RUN position, the contactor circuit is then completed by pressing the push button on the outside of the cabin to energize the relay.

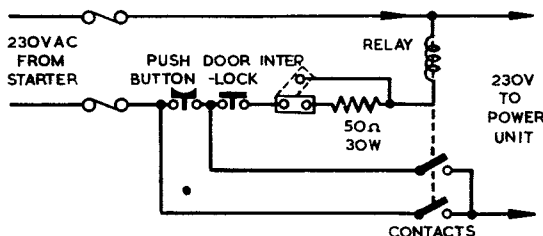

Fig. 24. Turning gears Type 52 and 53 : contactor unit circuit

The 230V 50 c/s supply is then passed on to the torque amplifier power unit. The circuits in turning gears Type 52 and 53 are identical.

**Starter unit Type 13**

71. As shown in fig. 25, when the starting handle is pushed down, 230 volts are applied across Z1, Z2 via a 100 μF capacity. When the starting handle is pulled up the voltage is applied to Z1, Z2 via a 25 μF capacity. Fig. 25 also shows the connections in START and RUN positions.

**HEIGHT-FINDER AZIMUTH TURNING GEAR**

72. This is the aerial turning gear Type 53, setting-up instructions for which are given in Chap. 3, para 154 to 158. A circuit diagram of the gear will be found in A.P.2525X.

**Brief description of the system**

73. Turning gear Type 53 is similar to turning gear Type 52. The main difference lies in the method of control from the operations room. As shown in fig. 26, which is a block diagram of the system, control unit Type 442, unlike control unit Type 443, does not employ a pilot motor to turn its selsyn for continuous rotation. Instead a steady voltage is fed from the control unit

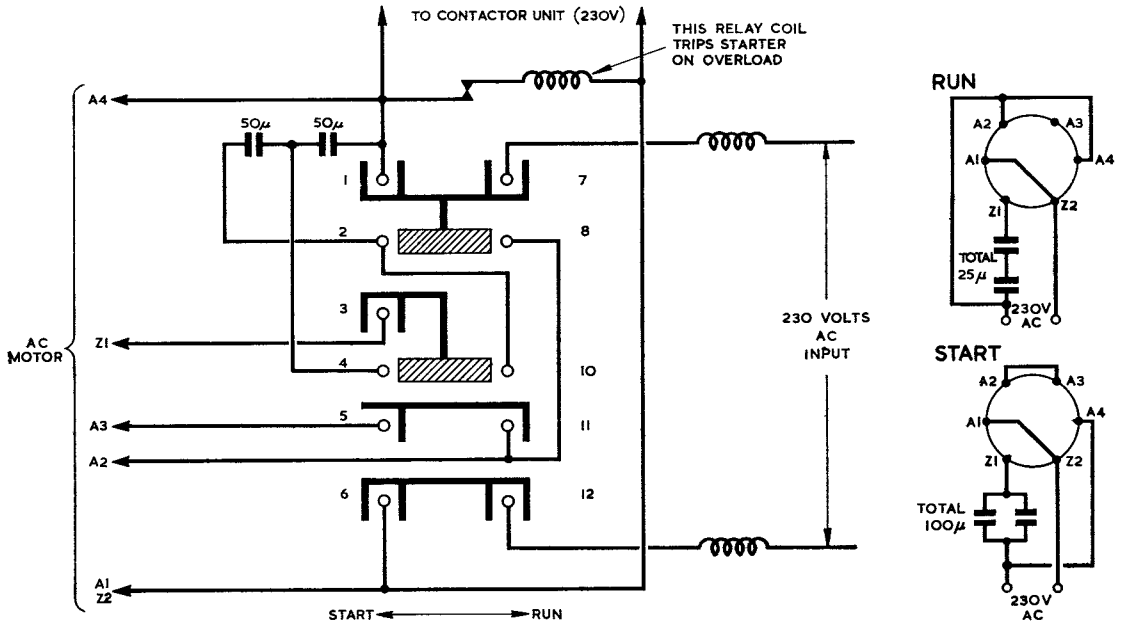

Fig. 25. Starter Type 13 : circuit

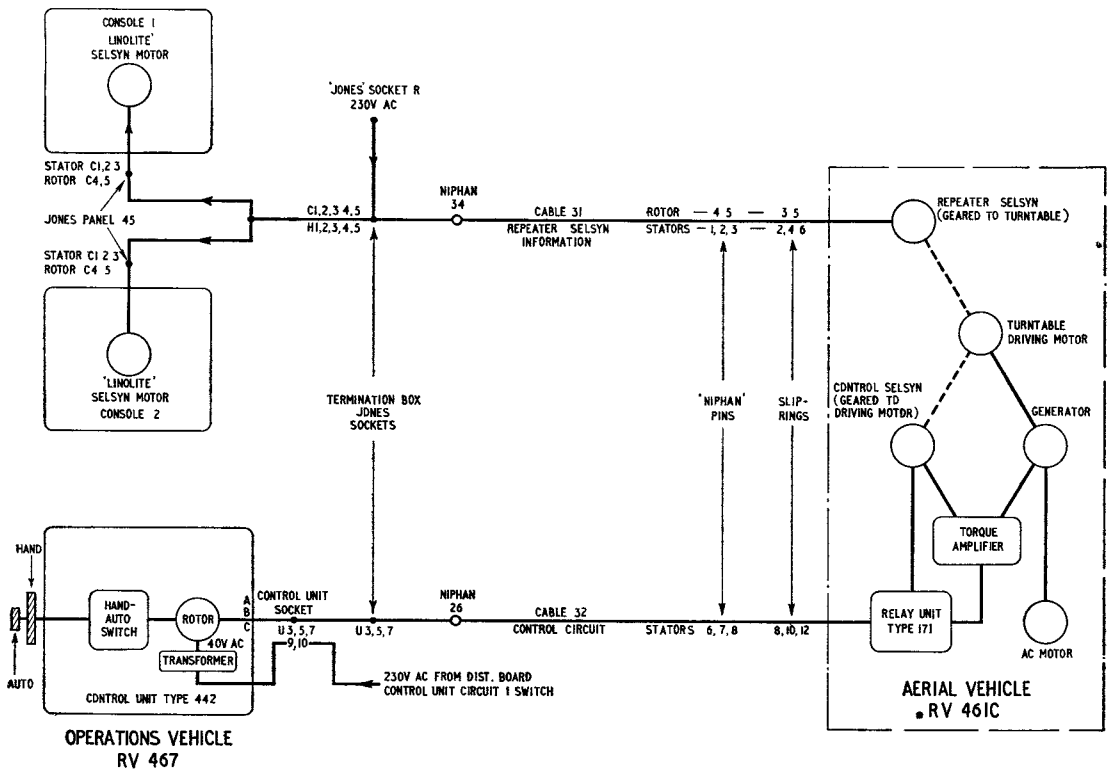

Fig. 26. Height-finder azimuth turning gear : block diagram

selsyn direct to the torque amplifier. The amplitude and polarity of the steady voltage are controlled by the knobs on the front panel of the control unit.

**74.** Provision for hand turning is, as usual, by connecting a hand wheel to the rotor of the control selsyn whose stator coils are coupled to a similar motor in the aerial cabin.

**75.** There is a further difference between the two types of turning gear. In turning gear Type 52 the ratio of cabin rotation to control selsyn rotation is 4 : 1, whereas in turning gear Type 53 it is 1 : 1.

**76.** The change from AUTOMATIC to HAND turning is effected by withdrawing the two knobs on the front panel of control unit Type 442 at zero speed. As shown in fig. 27 a micro switch then releases a relay in relay unit Type 171 and the two selsyns are connected up.

**Aerial tilting circuit**

**77.** In the circuit of fig. 28, when the elevation control switch, located on the

distribution board, is switched on, the 230V 50 c/s mains supply is routed to the aerial vehicle. Then to energize the tilting motor the MEM contactor must be closed. This involves having the elevation control switch on in the display unit of console 3 when 230V 50 c/s is supplied to the master switch in R.V.461C. When the master switch is on, the MEM contactor is energized and the contacts apply 230V 50 c/s to the tilting motor.

**78.** Opening either the elevation control switch on the distribution board or the console 3 elevation control switch only, allows the motor to run until switch Type 1172, which is attached to the drive shaft, opens. The position of this switch can be varied so that the aerial will always come to rest in a pre-selected position, usually vertical.

**Production of the elevation scan waveform**

**79.** As shown schematically in fig. 29, a 3 kc/s sinusoidal waveform of constant amplitude is generated by V1 in scanning

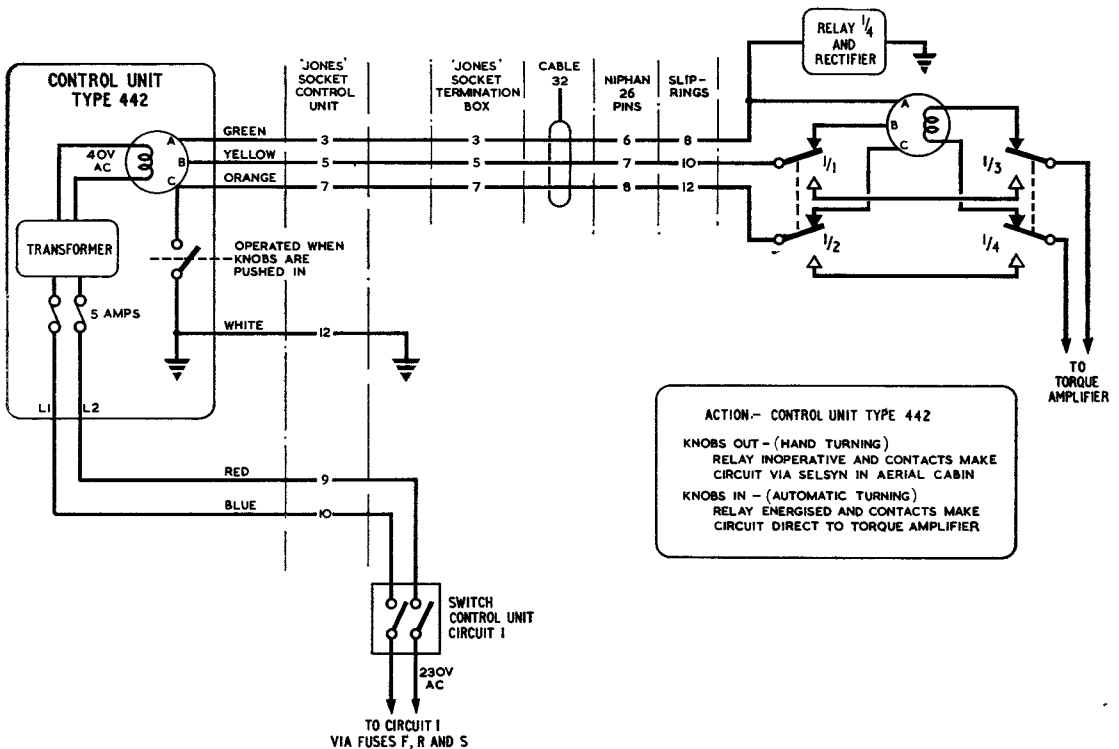

**Fig. 27. Operation of relay unit Type 171**

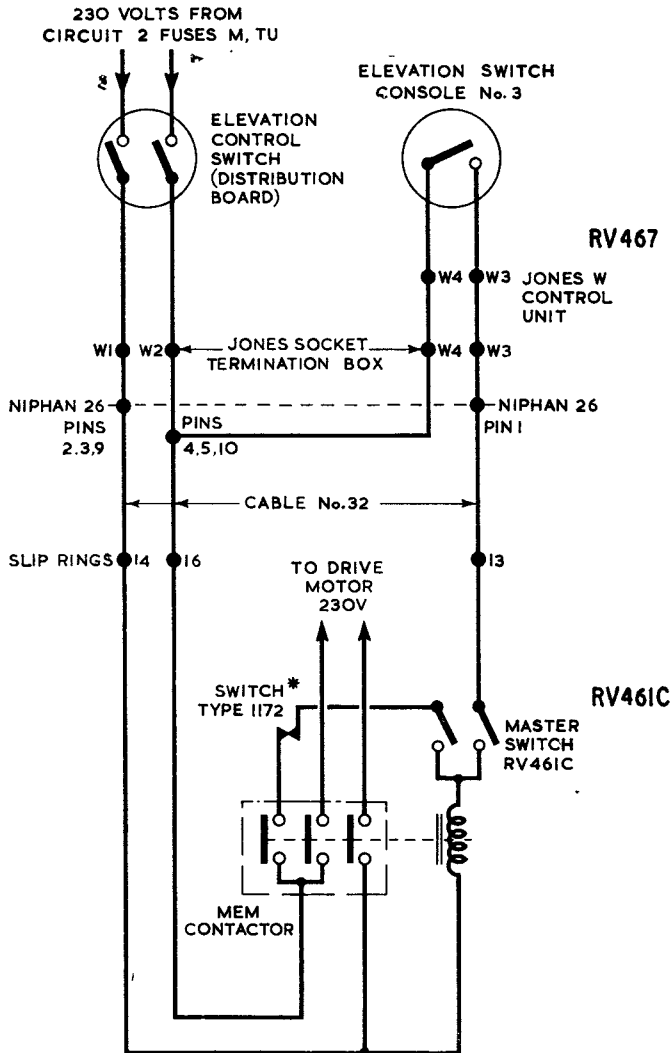

\* NOTE:- IF MOD. No.405/1 IS INCORPORATED, SWITCH TYPE 1172 WILL NOT BE IN THIS CIRCUIT, THE CONNECTION BEING STRAIGHT THROUGH

Fig. 28. Aerial tilting gear : circuit

unit Type 14. It is fed to the stator coil of a mag slip mounted on the height finder aerial framework. The amplitude of the waveform is varied by a control, MAG OUT.

**80.** The rotor coil picks up a voltage whose amplitude is proportional to the degree of coupling between the coils and, as the rotor

is attached to the tilting reflector, voltage transfer varies with tilt angle.

**81.** This voltage from the rotor coil is used to drive the scanning circuits in such a manner that Y deflection is proportional to angle of tilt. The SET ZERO control determines the minimum amount of drive.

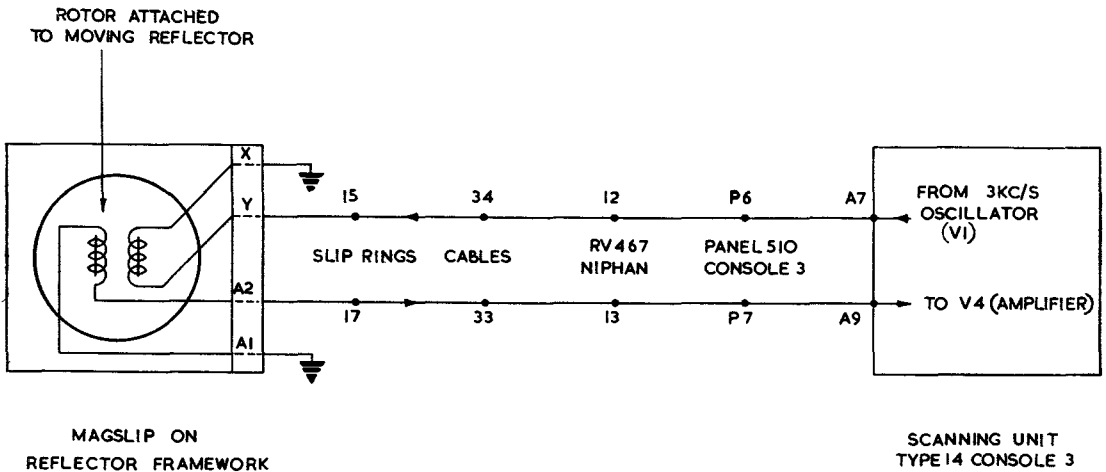

Fig. 29. Production of elevation scan : schematic diagram

## INFORMATION ON TR.3561

### General

**82.** The block diagram of the modulator and transmitter (*fig. 30*) and of the monitoring unit and head amplifier (*fig. 31*) have been included for general guidance. For detailed circuitry refer to A.P.2525L.

**83.** Waveforms at points A to F in TR.3561 are given in *fig. 64*.

### The magnetron

**84.** Valves CV76 A, B, C and D have been superseded by valves CV1479, 1480, 1481 and 1482 respectively. The following are their frequencies and wavelengths :—

CV1479 : 3,060 to 3,030 Mc/s,  
9.804 to 9.9 cm.

CV1480 : 3,030 to 3,005 Mc/s,  
9.9 to 9.99 cm.

CV1481 : 3,005 to 2,908 Mc/s,  
9.99 to 10.067 cm.

CV1482 : 2,908 to 2,940 Mc/s,  
10.067 to 10.204 cm.

### Retaping the waveguide

**85.** Under normal conditions the waveguide will have to be retaped with Scotch acetate tape every two months. The correct tape has Stores Reference 132B/34. Proceed as follows :—

- (1) Strip off the old tape taking care not to damage the waveguide.

- (2) Tape each slot in turn with two layers of tape.

#### Note . . .

*Do not wind the tape round continuously but cut it after treating each slot to avoid untidy overlap.*

- (3) Apply a coat of varnish (Stores Ref. 32B/573) over the slotted portion of the waveguide.

### The local oscillator

**86.** This is the CV67 klystron whose electrode potentials are as follows :—

Resonator	earth
Cathode	approx. -1,700V
Grid	30-60V negative to cathode
Reflector	200V negative to cathode
Heaters	6.3V AC

The base connections are shown in *fig. 63*.

**87.** There are two power supplies for the CV67. One is a 2,000V supply from a CV1120 and the other a 200V floating supply from a metal rectifier.

### Monitor Type 53 (*fig. 31*)

**88.** There are two power supplies for the monitor Type 53. The 2,000V for the CRT is from a CV1120 rectifier. A jack socket labelled OSC. CURRENT, which gives a reading



of indicator and soft rhumbatron currents, is provided to check the power supply.

**89.** The other supply is 400V from a CV575 and a CV1863. This supply can be checked by the operation of the shift controls. If there is only a spot on the CRT the shift controls should move the spot if the 400V supply is present.

#### *Waveform inspection*

**90.** A socket labelled MONITOR is connected to one Y-plate of the CRT. It will be necessary to make up a short lead having a probe and earth clip at one end, and a two-pole jack at the other end. The probe can then be used to display the waveforms at various circuit points. These waveforms are shown in fig. 65.

#### **Crystals used in TR.3561**

**91.** The correct crystal is CV103, but CV102 or CV113 may be used in an emergency.

**92.** Care should be taken not to expose the crystals to RF fields and they are also liable

to damage if jarred. When changing the crystals in the mixer box, switch off the transmitter first and always keep spare crystals in a metal box.

**93.** Deterioration of the crystals is shown by a drop in receiver sensitivity and trial by substitution is the only reliable method of checking their serviceability. For this purpose it is best to have a good standard CV103 for comparison tests.

**94.** It should be noted that each time the crystal in the receiving unit mixer box is changed, the mixer and matching units should be retuned.

#### **Care of the magnet**

**95.** The field strength of the magnet should be 2,200 gauss. Tools of magnetic material should be kept well away from the magnet, and a keeper should never be placed across the pole faces. If for any reason the unit has to be removed, place it in a safe position on a wooden base remote from any metal.

## **POWER SUPPLIES**

#### **The 500-cycle power supply**

**96.** The internal wiring of the power board is shown in fig. 32 ; fig. 33 shows the distribution to the TR.3561.

**97.** The alternator and AC motor are on a common shaft, the motor being controlled by a starting switch carrying the 230V AC via the MAIN SWITCH on the power board. In the START position (handle down) the 230V supply is fed via a phase splitting circuit to three windings and the motor operates as a 3-phase motor (*fig. 34b*). When the motor has attained full speed it is switched to single-phase operation by pushing the handle smartly up into the RUN position (*fig. 34c*). A stop button is included to release the handle and stop the motor.

**98.** Starting current is about 60 amps, running current 35 amps. The overload should be set to trip at 60 amps. The rating of the AC motor is 5kW single phase and runs at 2,900 to 3,000 r.p.m.

#### *Maintenance*

**99.** The faults most liable to occur are overloads blowing one or more of the fuses in the power board or opening the main contactor. If the fuses blow, examine the particular circuit for possible defective components or short circuits before replacing the fuses.

**100.** The motor alternator and starter bearings should be lubricated **monthly** by giving one turn to the lubricator cap or, if grease nipples are fitted, insert a small quantity of grease with a gun. Do not over-lubricate. Examine the inside of the end shields and ensure that no grease is entering the machine. The starter contacts should be inspected **monthly** and, if there is any pitting, rub them with fine glass paper until all the surfaces are smooth.

#### *Current consumption*

**101.** The following approximate figures for each unit using the 500-cycle supply may be useful.

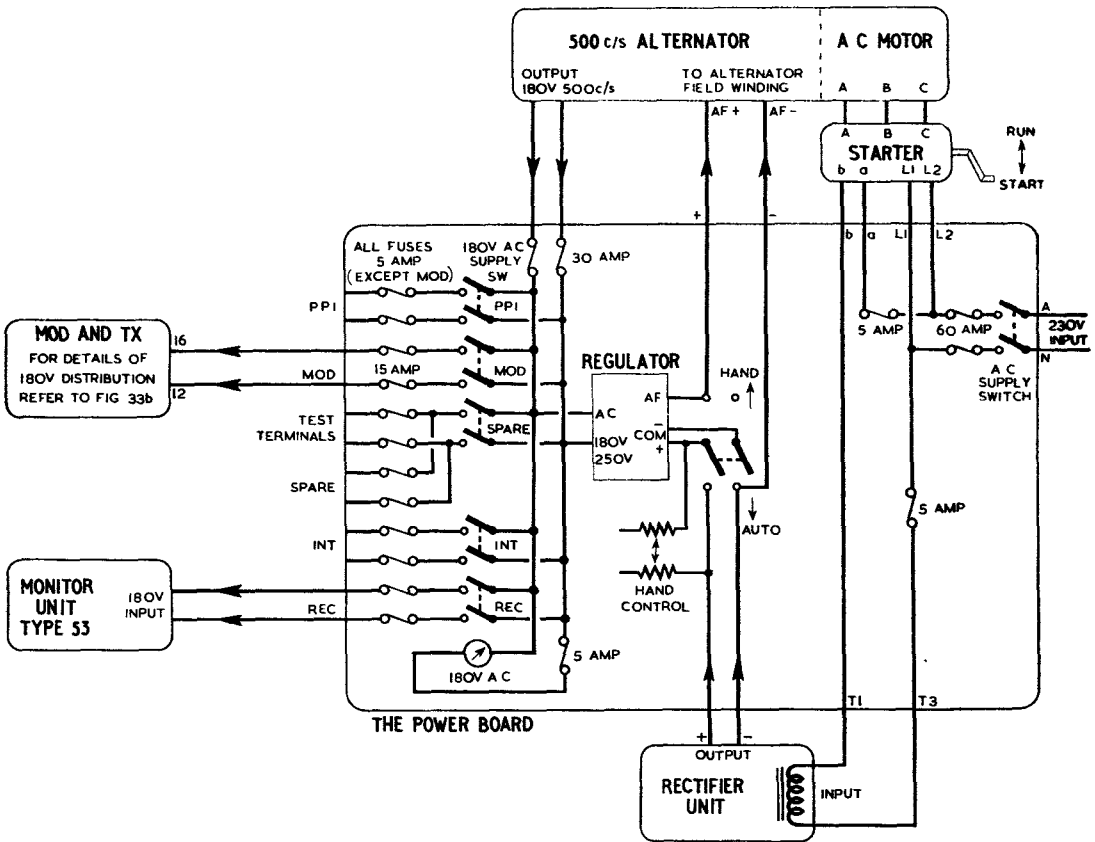

Fig. 32. 180V 500c/s power supply : wiring of power board

Receiver 1.15 amps; heater (mod.) 0.07 amp; blowers (mod) 20 amps. in START position, 3.5 amps. in RUN position; modulator and transmitter 11.8 amps.

#### The power board

**102.** The AC SUPPLY SWITCH in the centre of the board, above the regulator box, routes 230V, 50 c/s to the alternator starter panel and to the TEST and SPARE terminals.

**103.** There is a switch to supply power to the HEATER and BLOWER switches. The HEATER switch then routes 230V, 50 c/s to the receiver heaters (not used in this application) and to the modulator heaters. The BLOWER switch starts the blower in the modulator compartment and feeds the supply to auxiliary circuits in the modulator compartment.

#### The carbon-pile regulator

**104.** This consists essentially of a number of carbon discs arranged in a pile; the resistance of the pile, which is in series with the generator field, can be varied according to the pressure applied. The movable plungers, which control the amount of pressure, are attached to a spring which is opposed by the movement of the armature of an electro-magnet. The current passing through the electro-magnet coil comes from the AC voltage to be controlled, via a metal rectifier.

**105.** When there is no current the spring compresses the carbon pile to minimum resistance (about 10 ohms). An increase in the AC voltage increases the attractive force on the armature and decreases the pressure on the carbon pile whose resistance thereby increases and vice versa. Thus a steady state is reached which is set to give the AC voltage required.

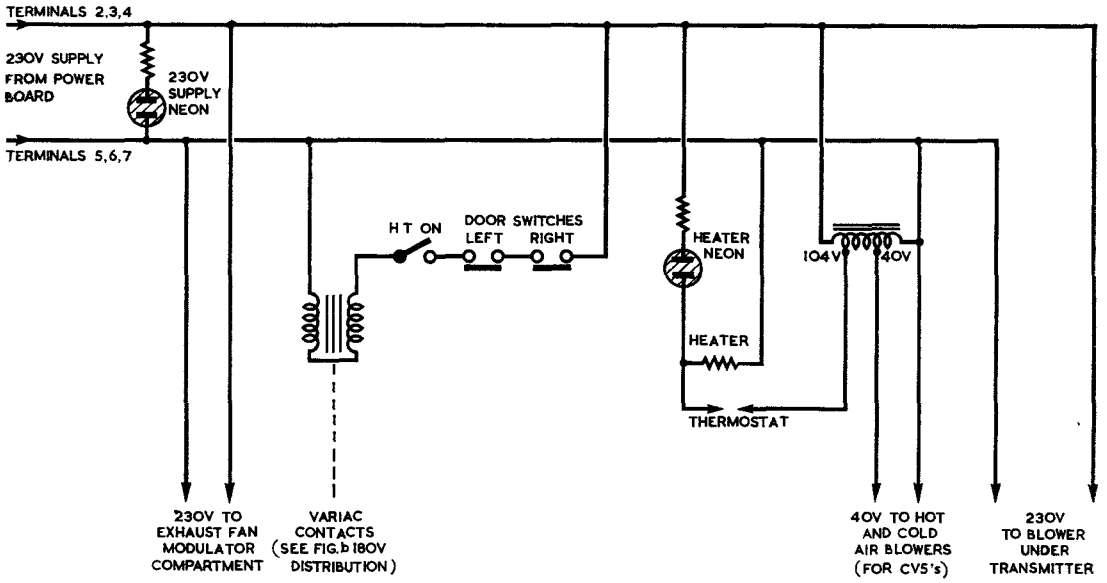

(a) 230V A C CIRCUIT

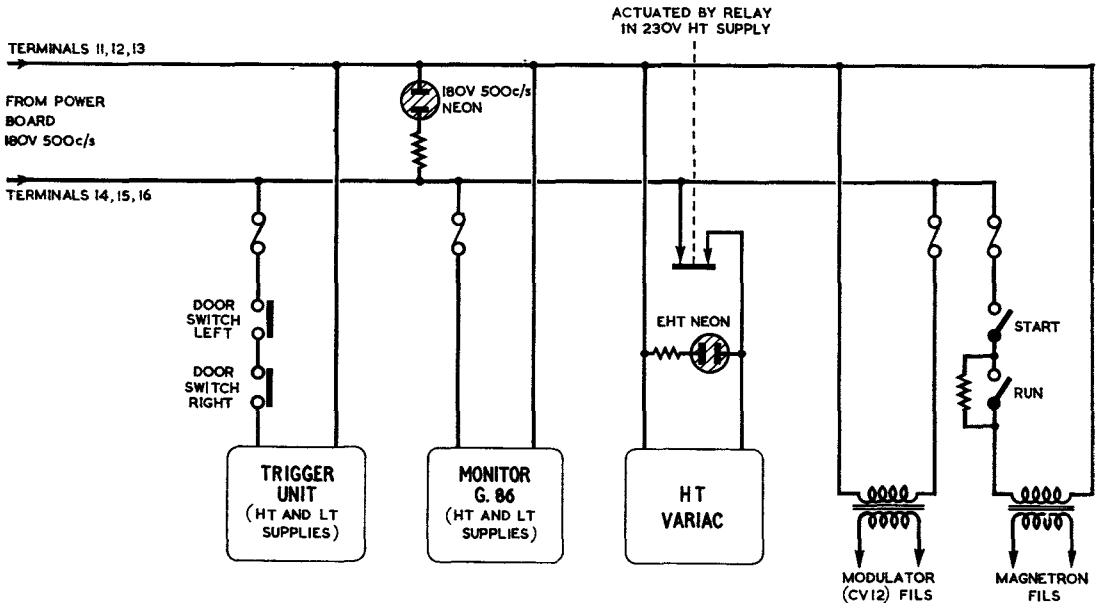

(b) 180V DISTRIBUTION

Fig. 33. TR.3561 : power supply distribution

"OFF"

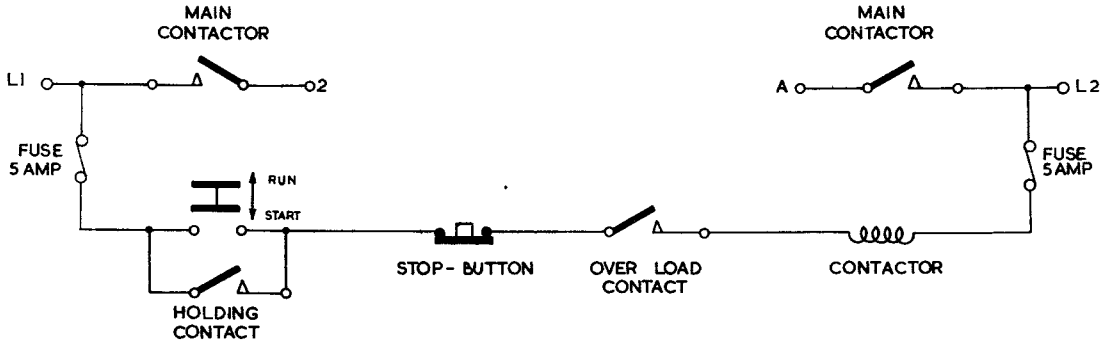

"START"

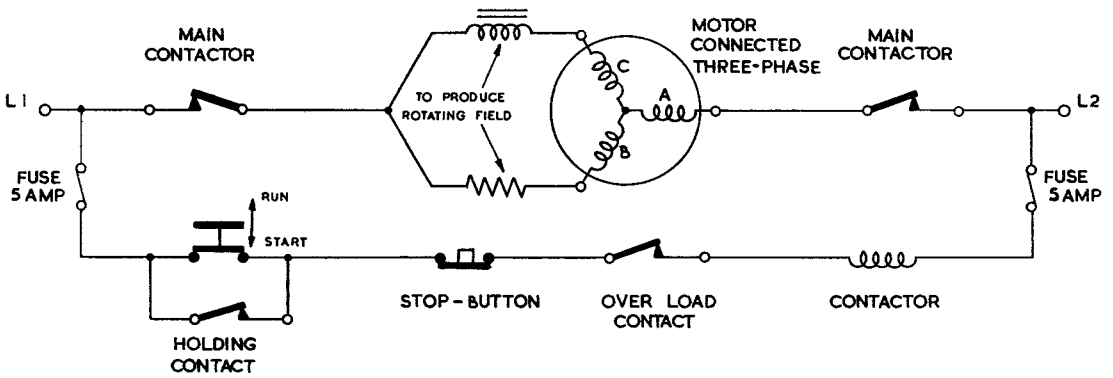

"RUN"

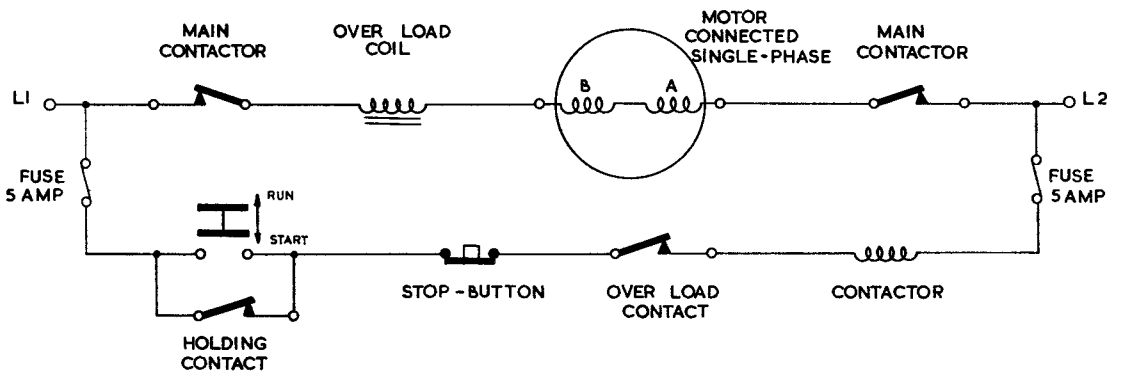

Fig. 34. 500 c/s supply starter unit : circuit

**106.** If the regulator fails, the voltage can be controlled by hand by putting the HAND-AUTO switch to HAND, and using the field regulator which is engraved RAISE VOLTS. Before starting the motor alternator the field regulator should be turned as far as possible in the DECREASE VOLTS direction when on HAND regulation.

#### *Adjustment of the carbon-pile regulator*

**107.** When the regulator hunts it will require adjustment as follows.

- (1) Unscrew the four screws securing the front cover and open the cover.
- (2) Mark with a pencil on the circular plate the position of each compression screw.
- (3) Check that the alternator is on no load (all output switches open).
- (4) Start the motor alternator and check that the DC supply voltage, which

should be steady throughout the adjustment, is correct.

- (5) Using an insulated screwdriver screw up each compression screw in turn one-eighth of a turn clockwise, ensuring that they are being kept in step by the relative positions of the pencil marks.
- (6) Continue turning as in (5) past the point where hunting stops, until the AC voltage starts to rise.

#### **Note . . .**

*The voltage may rise a little, temporarily, as each screw is being moved. This should be disregarded.*

- (7) Turn back one eighth of a turn the screw which was being moved when the voltage started to rise.
- (8) Tighten up all locking screws.
- (9) Close and secure the cover.

## **SIGNAL AND SYNC. PULSE CHAINS**

### **General**

**108.** It is often difficult to trace the path of a signal through various units and the following paragraphs will outline the paths of the radar signal and of the sync. pulse.

#### **The radar signal chain**

**109.** The paths of the outgoing pulse from the transmitter to the aerial and of the incoming pulse from the aerial to the display units are shown in fig. 35 in the case of the plan-position vehicle (AMES Type 14) and in fig. 36 for the height-finder (AMES Type 13).

**110.** Both signals are tuned while observing the monitor display which incorporates a narrow band IF unit centred on 45 Mc/s. The 45 Mc/s signal is fed to display unit Type 5; to consoles 1 and 2 from the plan position vehicle; and to console 3 from the height-finder.

**111.** Three separate interference rejecting devices, wired to keys on the control desks, may be brought into circuit individually. The calibrator key is used to feed calibration markers or signals into the indicating unit.

#### **The sync. pulse chain**

**112.** The path taken by the sync. pulse is shown in fig. 37. It should be noted that the local pulse oscillator provides negative sync. pulses when the SYNC. switch of panel Type 511 (or Type 509) is in position 1, labelled L.P.O. This facility is incorporated to allow the consoles to be set up with the transmitter off.

**113.** The sync. pulse from the plan-position transmitter (AMES Type 14) triggers the timebase of the IFF/RADAR indicator unit in console 3 as well as the display time bases of consoles 1 and 2. The pulse from the height-finder transmitter (AMES Type 13) triggers the timebase of console 3 only.

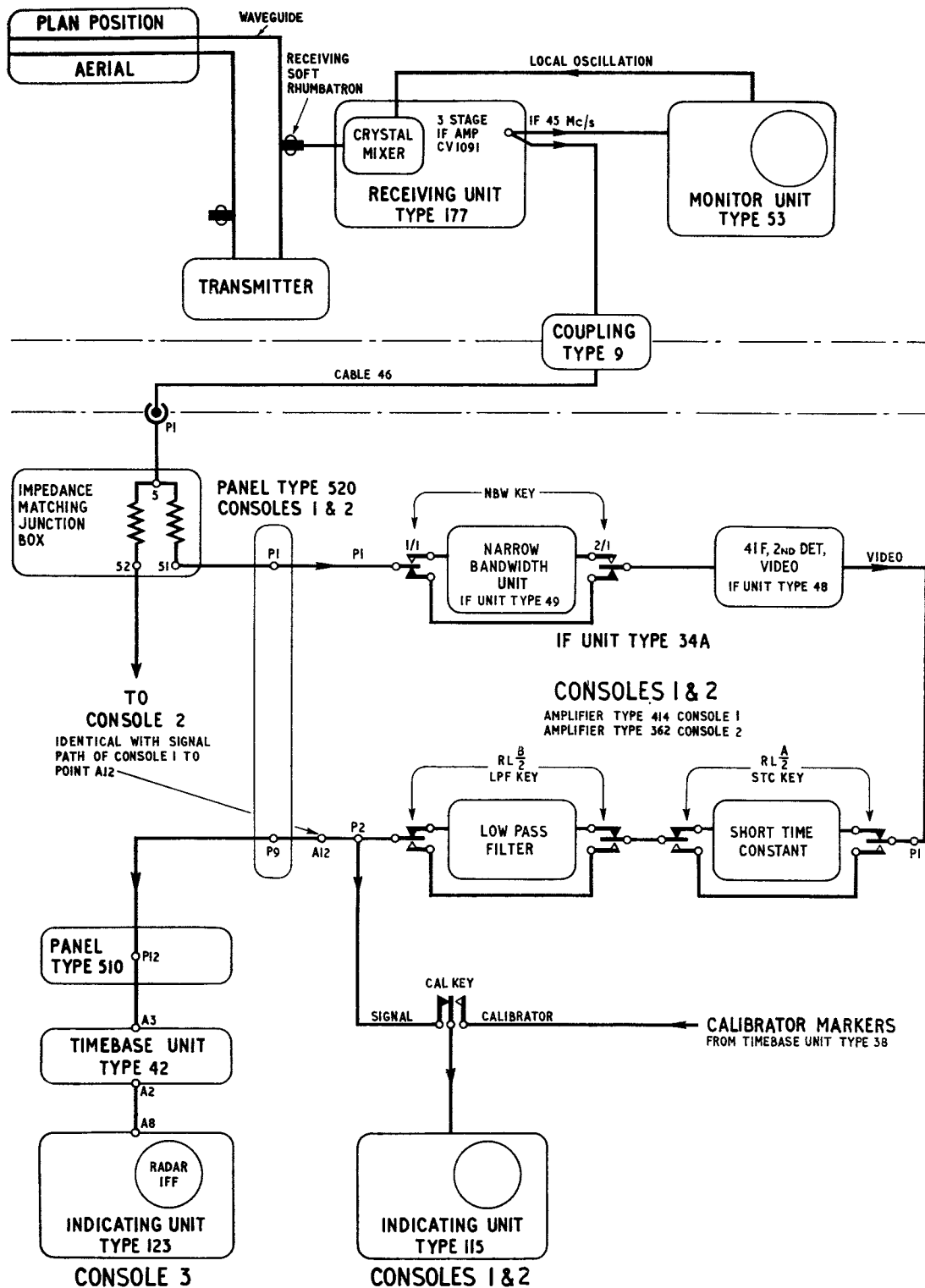

Fig. 35. Plan-position signal chain

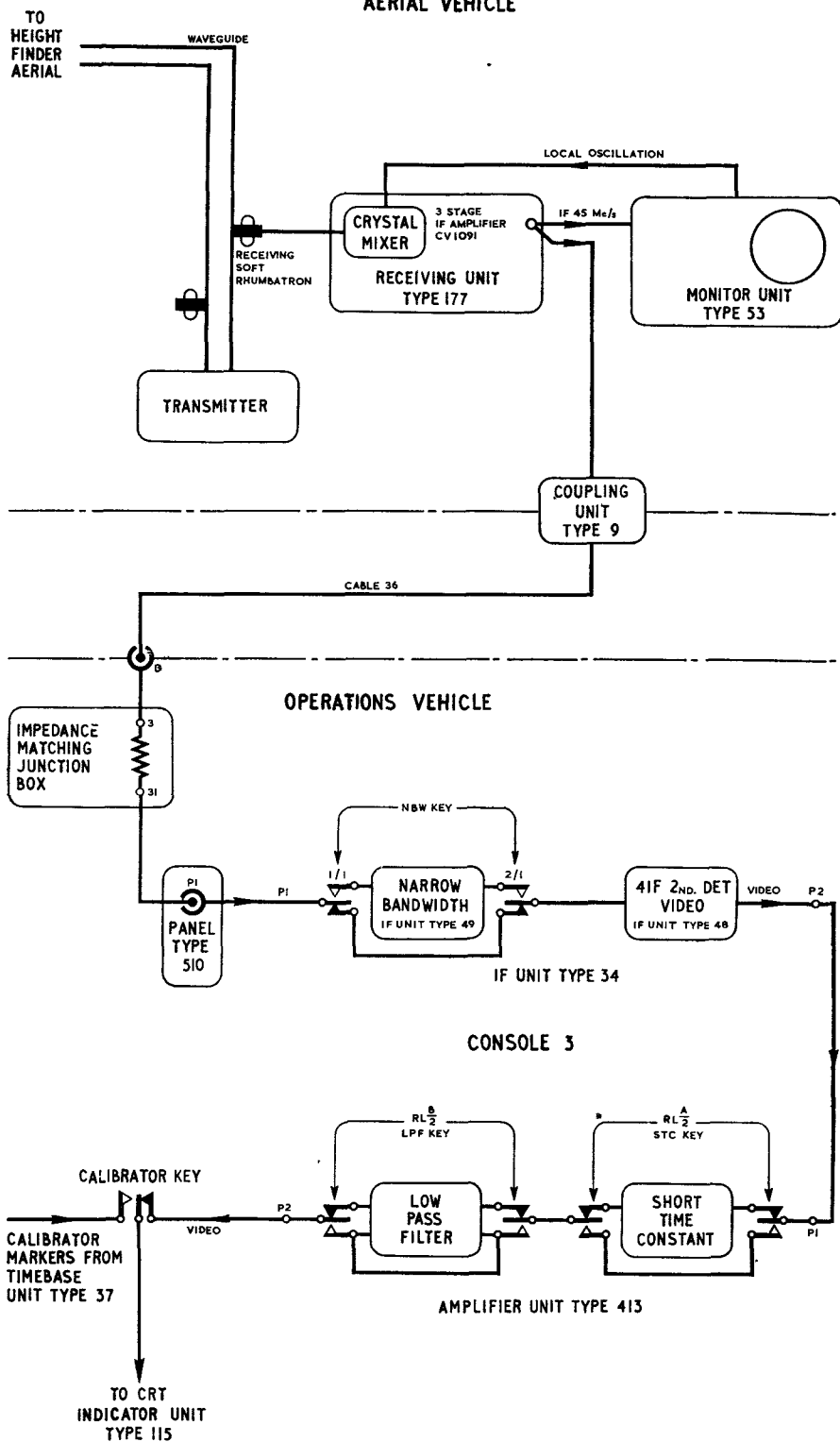

Fig. 36. Height-finder signal chain

RV 462C  
AMES TYPE 14

RV 461C  
AMES TYPE 13

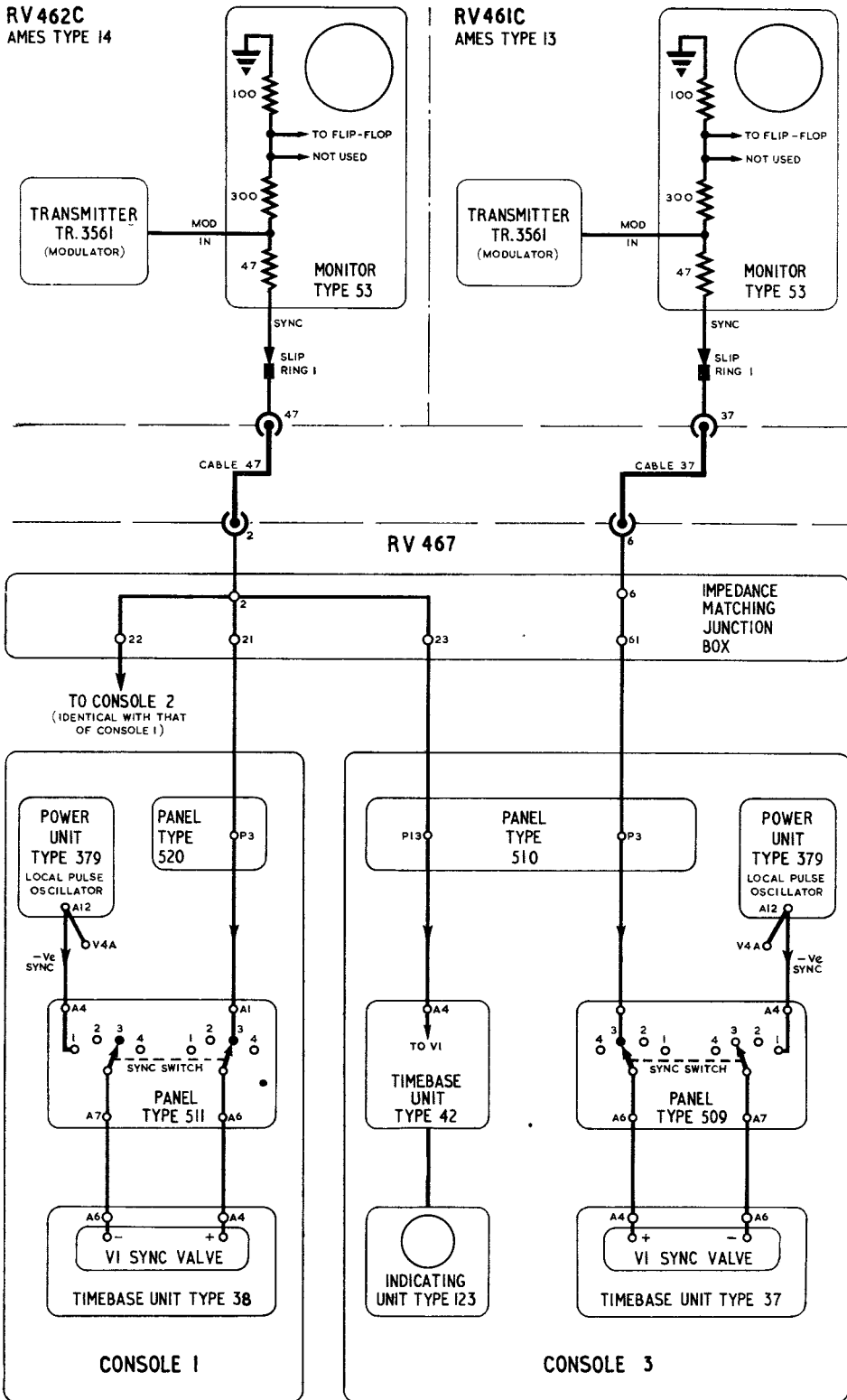

Fig. 37. Sync. pulse chain

## IFF SYSTEM

### A—BAND IFF

**114.** The A-band IFF equipment is installed inside the height-finder aerial vehicle. It employs the "Sippi" beam narrowing technique whereby the effective beam width of the IFF lobe is reduced to 4 deg., comparing favourably with the 5 deg. lobe of the radar beam.

**115.** As shown in fig. 38 a locking pulse from timebase unit Type 42 in console 3 of display unit Type 5 is passed via mixer unit Type 13 to the IFF transmitter. When the latter fires, RF is passed to both Yagi aerials in phase, giving the usual wide beam.

**116.** On reception two receivers are used. One, called the direct receiver, is fed via switch unit Type 271 but the other, the narrowing receiver, is fed with a signal reversed in phase by the "Sippi" diamond. The video outputs from both receivers are fed into mixer unit Type 13, where, after the narrowing signals have been amplified by a factor three, the two inputs are mixed. The resultant video signal is passed to indicating unit Type 123 in R.V.467.

#### Mixer unit Type 13

**117.** There are three power supplies in mixer unit Type 13, all of which are derived from one transformer. There are two 1 amp. fuses in the mains transformer primary.

**118.** A 300V HT supply at 60mA. is obtained from V17, a CV575 rectifier. If the osc switch is closed, the oscillator neon should light, indicating that the supply is present.

**119.** A 100V negative supply at 5mA is provided by rectifier V18, a CV1054. By switching the MTNC/NORMAL switch to MTNC the neon should glow proving this supply. As this supply has a high impedance it cannot be checked reliably with an Avometer. It should be checked with an oscilloscope.

**120.** The third supply is the 1,000V negative supply for the CRT from rectifier V19, a CV1120.

#### The selector switch

**121.** The functions of the selector switch are as follows.

(1) Position A (*Tune wavemeter*): the video inputs are disconnected and the wavemeter output is fed to the CRT.

(2) Position B (*Monitor narrowing Rx*): the input from the narrowing receiver is fed to the CRT.

(3) Position C (*Monitor direct Rx*): the input from the direct receiver is fed to the CRT.

(4) Position D (*Monitor video output*): the output from the video mixer is fed to the CRT.

#### Lock switch

**122.** In the NORMAL position of the LOCK switch, the lock pulse from display unit Type 5 is routed to transmitter Type T.3117 and to V1 of the mixer unit. In the MTNC position, V1 of the mixer unit is triggered from the 100V 50 c/s AC supply. The transmitter Type T.3117 is triggered from the output of V5 in the pulsing circuit.

#### Receivers Type R.3118

**123.** On the front panel of the receiver Type R.3118A there is a fuse which is in series with the mains input supply. Both the receivers Type R.3118A and B operate on an IF of 11.2 Mc/s, but the Type B has a bandwidth of 4 Mc/s at 6db. down, whereas Type A has a bandwidth of 2.3 Mc/s. The receiver chain may be checked by test set Type 172A, wavemeter Type W.649 or signal generator Type 53.

**124.** Voltage check points are provided on the front panel of the receiver. In addition, the following figures may be useful.

- (1) HT line, with no signal and gain at max., should be 165V.
- (2) The HT current consumption should be 120mA.
- (3) There should be 280V AC on each half of the HT winding.
- (4) The heater volts are 6.3V AC with 5V AC for the rectifier.

YAGI AERIALS

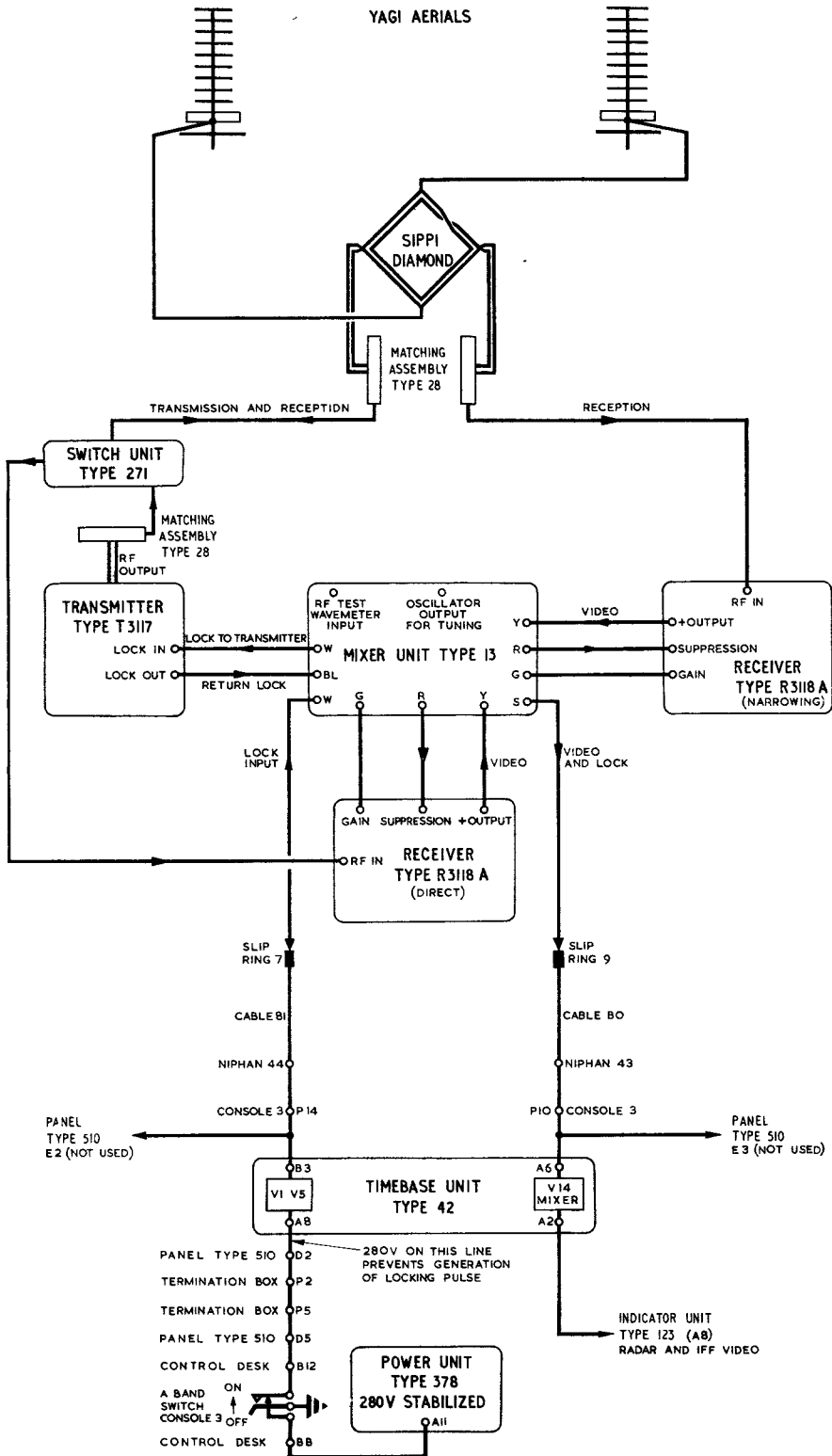

Fig. 38. IFF A-band signal chain

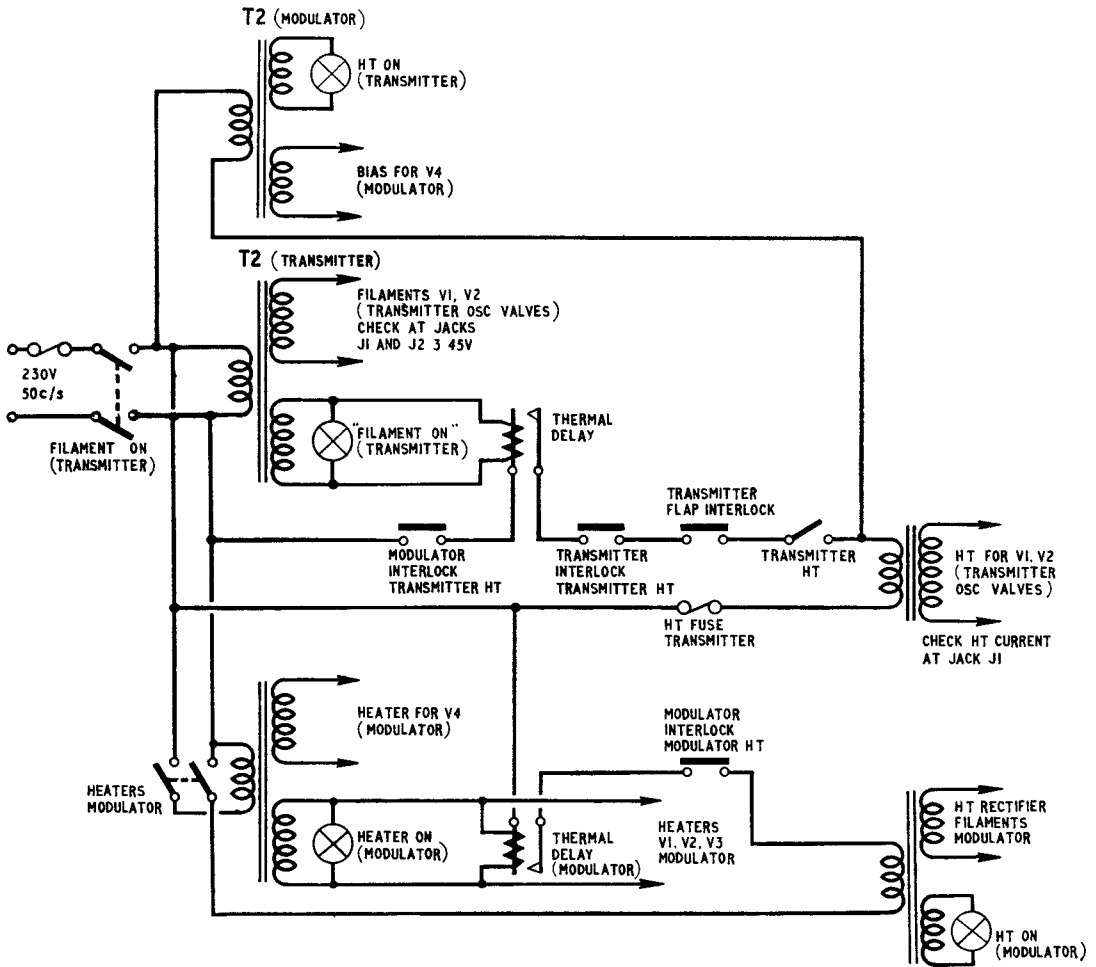

Fig. 39. Transmitter Type T.3117 : control circuit

#### Transmitter Type T.3117

**125.** When the transmitter is radiating, a blue glow will be observed between the electrodes of the spark gaps in switch unit Type 271. Otherwise monitor Type 33 may be used to check the operation of the transmitter and its modulator as described in para. 18. As the control circuit is rather involved a simplified diagram is given in fig. 39.

**126.** The interlock switches are likely to give most trouble. There is one which closes only when the transmitter is firmly in its case and there are two similar switches on the modulator chassis. Another interlock, the flap interlock, opens whenever the

cover over the oscillator valves is opened. Also, to complete the circuit, the two units must be used together.

**127.** If a milliammeter is plugged into J1 with the sync. pulse input disconnected from the transmitter and the HT switched on, a peak current due to C18 charging will be observed and the current will then fall to zero. If the meter does not read zero but shows a large amount of instability or a high reading, V1 or V2 is probably soft and should be changed.

**128.** The power output, approximately 1kW peak, may be checked by test set Type 102 as described in para. 47-50.

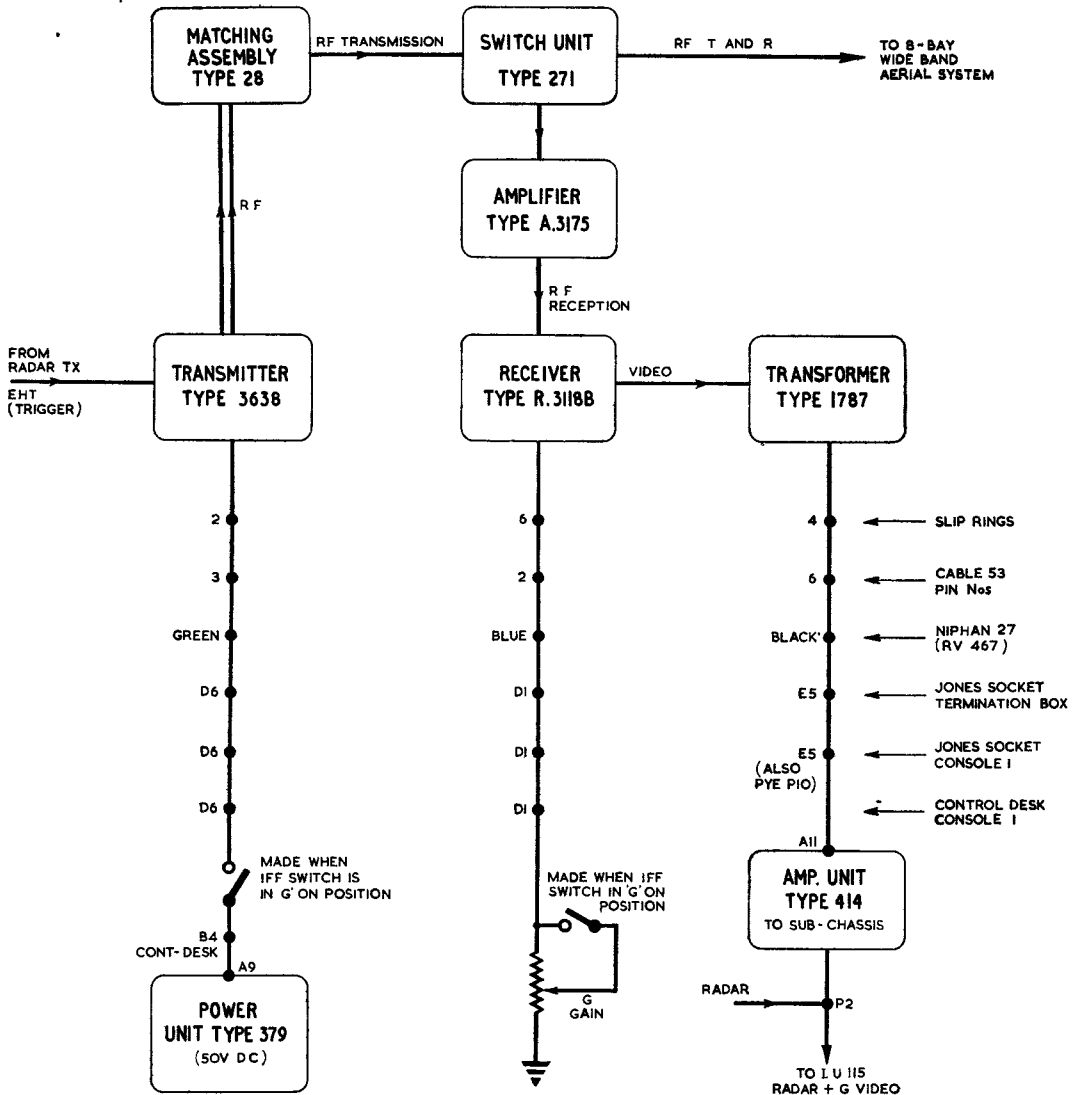

Fig. 40. G-band IFF : schematic diagram

### G—BAND IFF

129. A schematic diagram of the G-band IFF system is given in fig. 40.

#### Transmitter Type T.3638

130. The transmitter has a built-in power supply, of low voltage only, as follows.

- (1) 8·25V AC to the oscillator valves.
- (2) 24V DC to the blower motor.
- (3) 6·3V or 4V AC for CV1092 or CV1078 in the monitor.

A fuse is fitted in series with each lead of the 230V AC input to the unit. The blower motor brushes should be inspected occasionally and any erratic running of the motor should be investigated at once.

#### Switch unit Type 271

131. The only maintenance necessary should be to change the spark gaps. The average life of the CV1507 is about 1,000 hours.

**Amplifier Type A.3175**

**132.** This unit has its own power supply with two 500mA fuses in the primary circuit. It may be tuned over the range 190 to 220 Mc/s by trimmers in the anode circuit of each valve.

**Band switching**

**133.** The switch, A ON-OFF-G ON, on console 1 control desk has two functions in the G ON position (fig. 40).

(1) 50V DC is passed to the G-band transmitter and energizes a relay which permits the transmitter to oscillate. The EHT acts as a sync. pulse.

(2) The G-band remote gain control is brought into circuit.

It should be noted that G-band signals cannot be displayed on console 2.

**THE DISPLAY CONSOLES**

**General**

**134.** Fig. 41 shows the positions of all the panels in consoles 1, 2 and 3.

**Cabling**

**135.** For ease in identification the co-axial cables connecting the various units are coloured and a complete cabling schedule is given in Chap. 2. It will be useful to remember the following main colours and services.

- (1) YELLOW connects termination box to impedance matching junction box.
- (2) RED connects console 1 to junction box and termination box.
- (3) BLUE connects console 2 to junction box.

(4) GREEN connects console 3 to junction box.

**136.** In the case of inter-console cables the identification consists of three colours. The first and second denote the respective consoles (as above). The third colour denotes the service (*yellow* for strobe pulse ; *white* for calibration markers ; *black* for video).

**R.V.467 Jones sockets**

**137.** The layout of all Jones sockets in the vehicle is shown in fig. 42. Sockets U, W, V and Y are for aerial control units. X is for A-band IFF video when the A-band IFF in AMES Type 14 is used. Z is for 400V 3-phase mains supply which

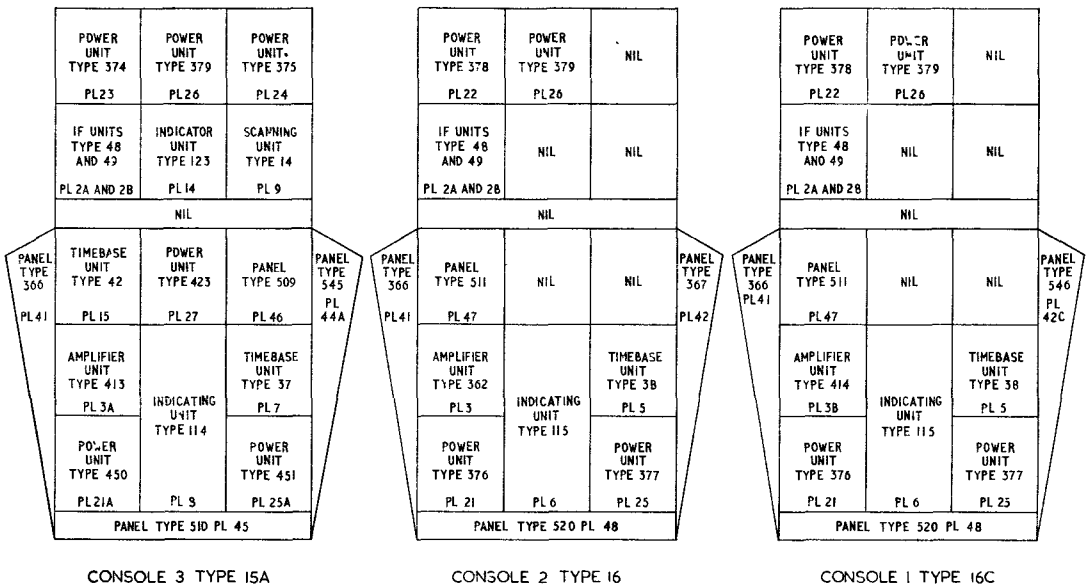

**Fig. 41. Display consoles : layout of panels**

is not in use. Those marked A-Y inside the termination box are used when connecting external cables to the vehicle and also for inter-console routing.

### Current and voltage checks

**138.** A monitoring system is provided to facilitate checking of current and voltage throughout display unit Type 5. A milliammeter on power unit Type 379 can be switched to various points in the power unit circuit or to a jack. The meter may then be connected to any other panel on the console by a jack cord. On each panel is a switch for monitoring various circuit points in that panel.

**139.** The meter requires 1mA for full-scale deflection and various shunts and series resistors are incorporated in the meter circuits to cope with the variety of monitoring points encountered.

**140.** A chart fixed on the inside of the middle door of each console gives the full-scale reading for each position and the reading which should be obtained.

### The console control desk

**141.** The circuits associated with the various keys and controls of the control desks (panels Type 545, 367 and 546) are somewhat complex and involve most of the console panels. In an attempt to simplify these circuits, each one has been presented in schematic form but with details of all inter-connections to assist in fault-finding. Except where specified the keys have identical circuits on all consoles.

#### Narrow bandwidth key (fig. 43)

**142.** When the key is depressed, 50V DC is applied to two relays in the narrow bandwidth IF unit and the 45 Mc/s signal is fed into it. The function of the narrow

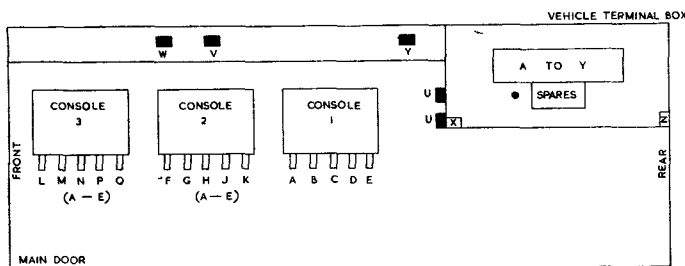

Fig. 42. R.V.467 : location of Jones sockets

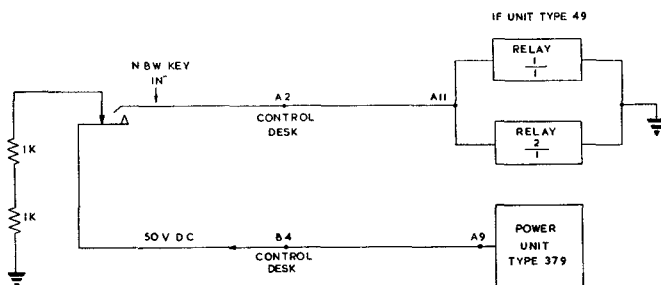

Fig. 43. Narrow bandwidth key

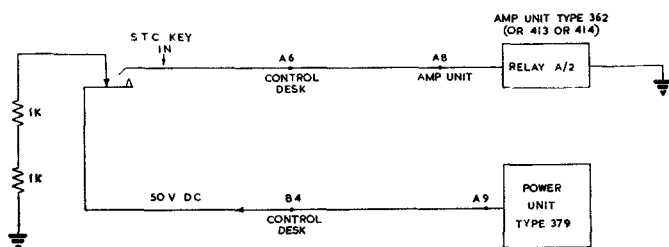

Fig. 44. Short-time constant key

bandwidth unit is to eliminate interference at frequencies other than that of the transmitter.

#### Short-time constant key (fig. 44)

**143.** When the key is depressed, 50V DC is applied to relay A/2 in the amplifier unit, switching in the short-time constant circuit. Use of this may help the operator in dealing with heavy CW interference.

#### Low-pass filter key (fig. 45)

**144.** The relay B/2 in the amplifier unit is actuated by 50V DC applied when the key

is depressed and this switches in the low-pass filter which cuts out all modulation frequencies above 500 kc/s and may prove useful in reducing the effects of interference.

**Calibrator key (fig. 46)**

**145.** With the key in the OFF position (fig. 47a), 140V DC is fed to the screen grids of the IF amplifier valves; the 280V DC from power unit Type 378 (or Type 375) is earthed via a 33K resistor and 50V DC from power unit Type 379 is earthed via a 1K resistor.

**146.** With the key ON (fig. 46b), the IF amplifiers are muted by the removal of the 140V DC from the screen grids; the 280V DC supply is applied to the calibrator oscillator circuit in the timebase unit and the 50V DC actuates a relay in the indicating unit, switching over from signal input to calibrator input.

**147.** It should be noted that, in the case of console 3, pins B8 and A12 on the control desk are permanently short circuited.

**Range key**

**148.** For consoles 1 and 2 the range key has three positions in which different range, linearity and velocity controls in the timebase unit are brought into circuit as shown in fig. 47.

**149.** Fig. 48 shows the two-position range key for console 3.

**IF gain control (fig. 49)**

**150.** This control varies the bias on the 1st and 2nd IF amplifiers, thus controlling their amplification.

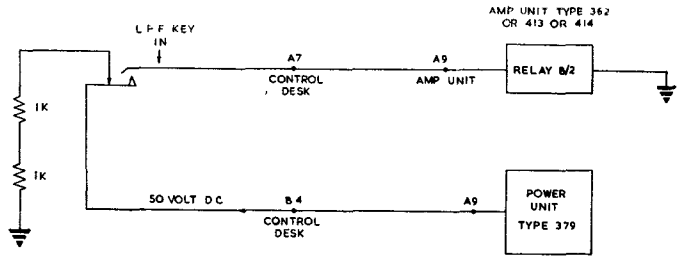

**Fig. 45. Low-pass filter key**

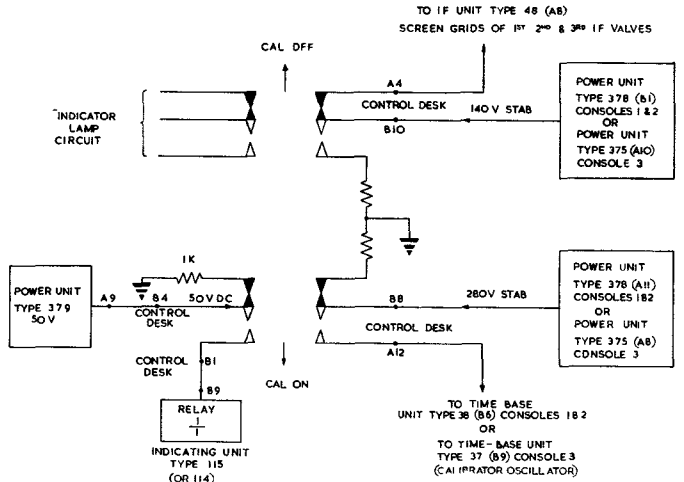

**Fig. 46. Calibrator key**

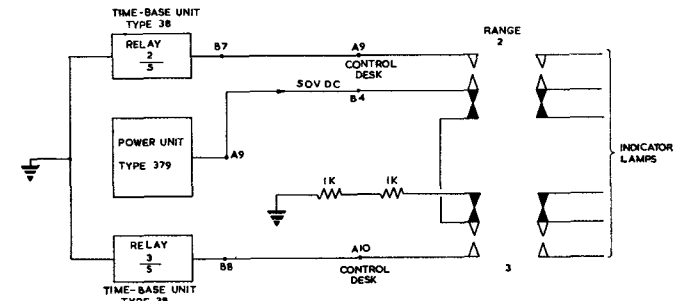

**Fig. 47. Range key (consoles 1 and 2)**

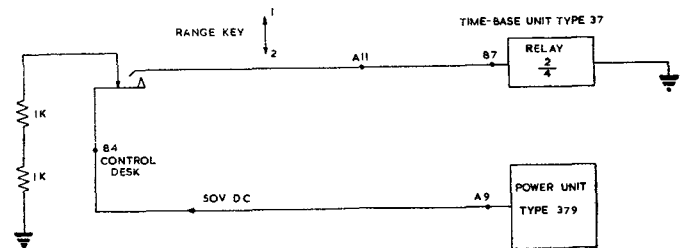

**Fig. 48. Range key (console 3)**

**Narrow bandwidth tune control**  
(fig. 50)

**151.** This potentiometer varies the bias on the reactance valve, thereby controlling the frequency of the narrow bandwidth oscillator to within  $\pm 0.5$  Mc/s.

**Remote strobe control** (fig. 51)

**152.** The strobing facility is provided to give range correlation between the PPI console 1 and the IFF display in indicating unit Type 123 on console 3. The potentiometer controls the voltage at the cathode of V16 in the timebase unit, and thus the position of the strobe pulse on the PPI and IFF indicator unit traces.

**Azimuth indicator key** (fig. 52)

**153.** When the key is depressed, 50V DC is applied to a relay in the timebase unit each time the switch on the aerial is made. This happens when the aerial turntable passes through a pre-determined azimuth and a brightening of the timebase trace occurs. By this means the alignment of the plan position aerial and the timebase trace can be checked. Azimuth indicator keys are to be found on consoles 1 and 2.

**154.** If mod. No. 405/1 in AP.2525S/1 is incorporated, the azimuth indicator key on console 3 is used to check the setting of the elevation scan. At a pre-determined angle of elevation the elevation strobe switch closes and, when the azimuth indicator key is on, the relay in indicating unit Type 114 is energized (fig. 53) causing a bright-up of the timebase trace.

**Indicator lamp circuit**

**155.** Most keys on the control desk operate an indicator

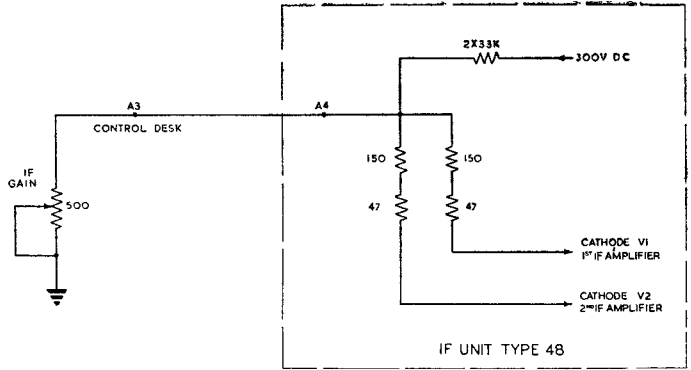

**Fig. 49. IF gain control**

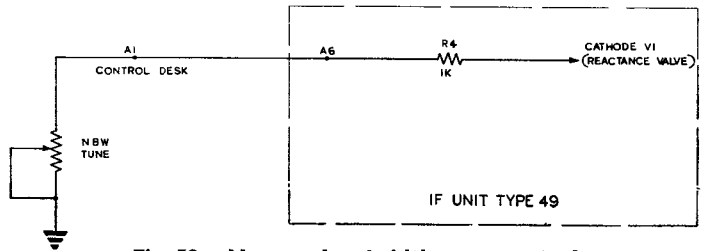

**Fig. 50. Narrow bandwidth tune control**

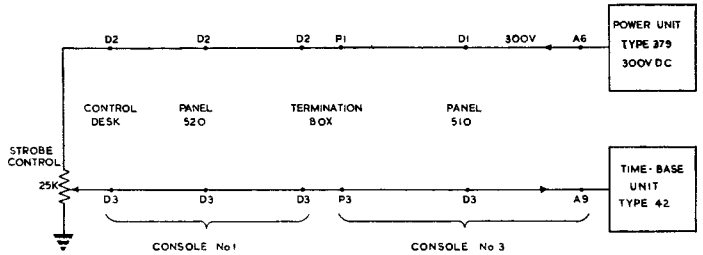

**Fig. 51. Remote strobe control**

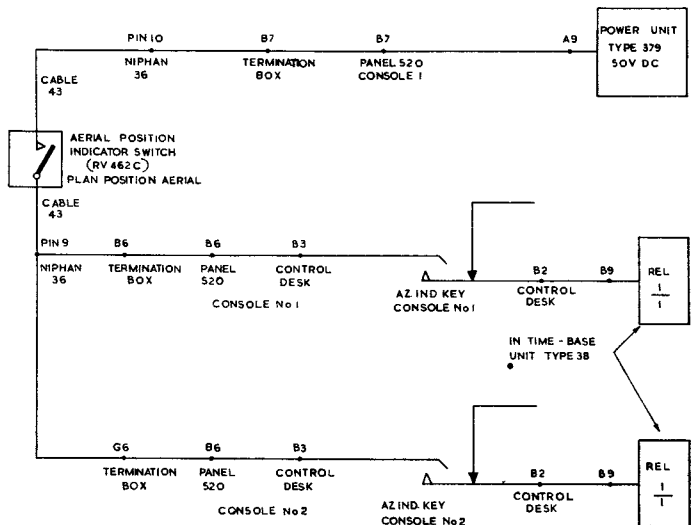

**Fig. 52. Azimuth indicator key (consoles 1 and 2)**

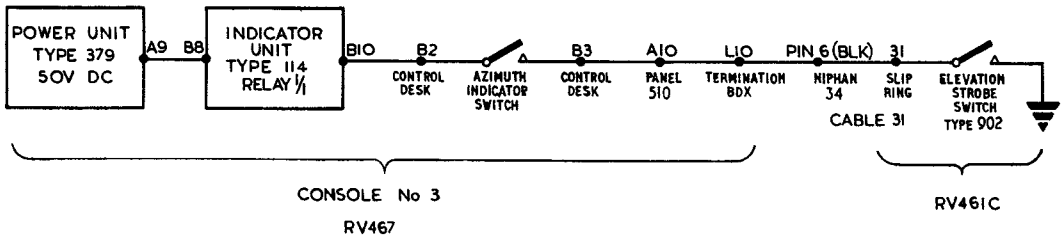

Fig. 53. Azimuth indicator key (console 3) : use for strobe facility

lamp circuit. For the sake of clarity these were omitted from the circuit diagrams. The circuit is the same in each case and is shown in fig. 54.

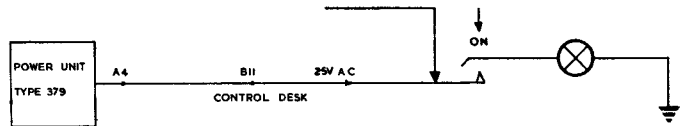

Fig. 54. Indicator lamp : circuit

*Aerial position indicator key (fig. 55)*

**156.** When the key is depressed, 50V DC is applied to an adjacent lamp (consoles 1 and 2) provided the switch attached to the aerial turntable is made. This happens whenever the aerial passes through a pre-determined azimuth. By observing the line-of-light bearing at the instant the lamp lights, the accuracy of the line-of-light indicator and therefore the alignment of the AMES Type 13 aerial azimuth can be checked. This facility is provided on consoles 1 and 2.

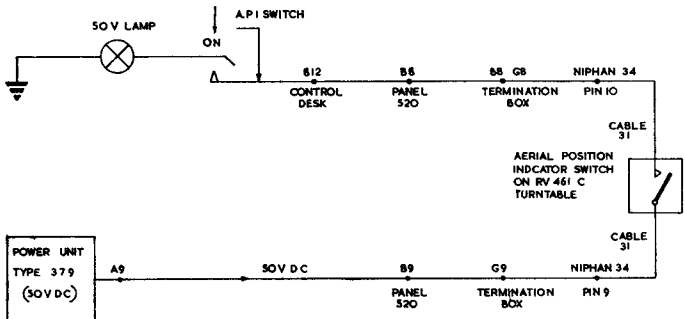

Fig. 55. Aerial position indicator key

*Mains supply switch*

**157.** Fig. 56 shows the pin connections for the mains supply through the mains supply switch to the power units.

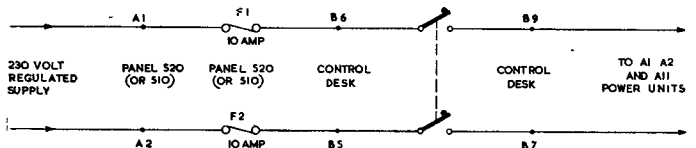

Fig. 56. Mains supply switch

*Inter-console cables (fig. 57)*

**158.** The following services combine to effect the range correlation of IFF and radar responses.

(1) A strobe pulse, previously mentioned in para. 152, is generated in console 3 and fed over to console 1 where it appears as a bright spot on the CRT.

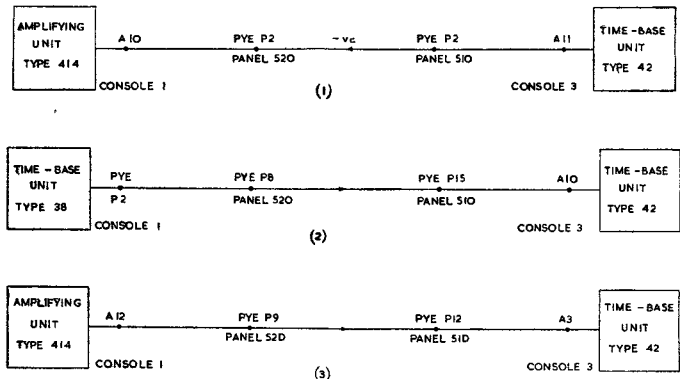

Fig. 57. Inter-console cabling

(2) Cal. pips for indicating unit Type 123 are fed from the calibrator circuit in time-base unit Type 38. These markers are at 5-mile intervals.

(3) Video signals from the plan-position station are fed to console 3 for display on indicating unit Type 123.

**The console air blower system**

159. The temperature inside each console can be thermostatically controlled to a few degrees above ambient temperature to prevent deposition of moisture inside the console.

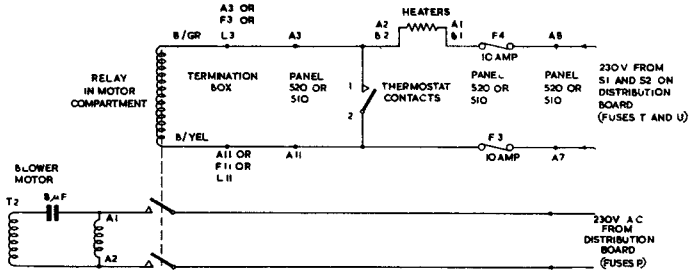

**Fig. 58. Blower motor circuit**

160. The system is shown schematically in fig. 58. When the temperature inside the console is below that required, the thermostat contacts are closed and 230V 50 c/s is applied only to the heaters. The

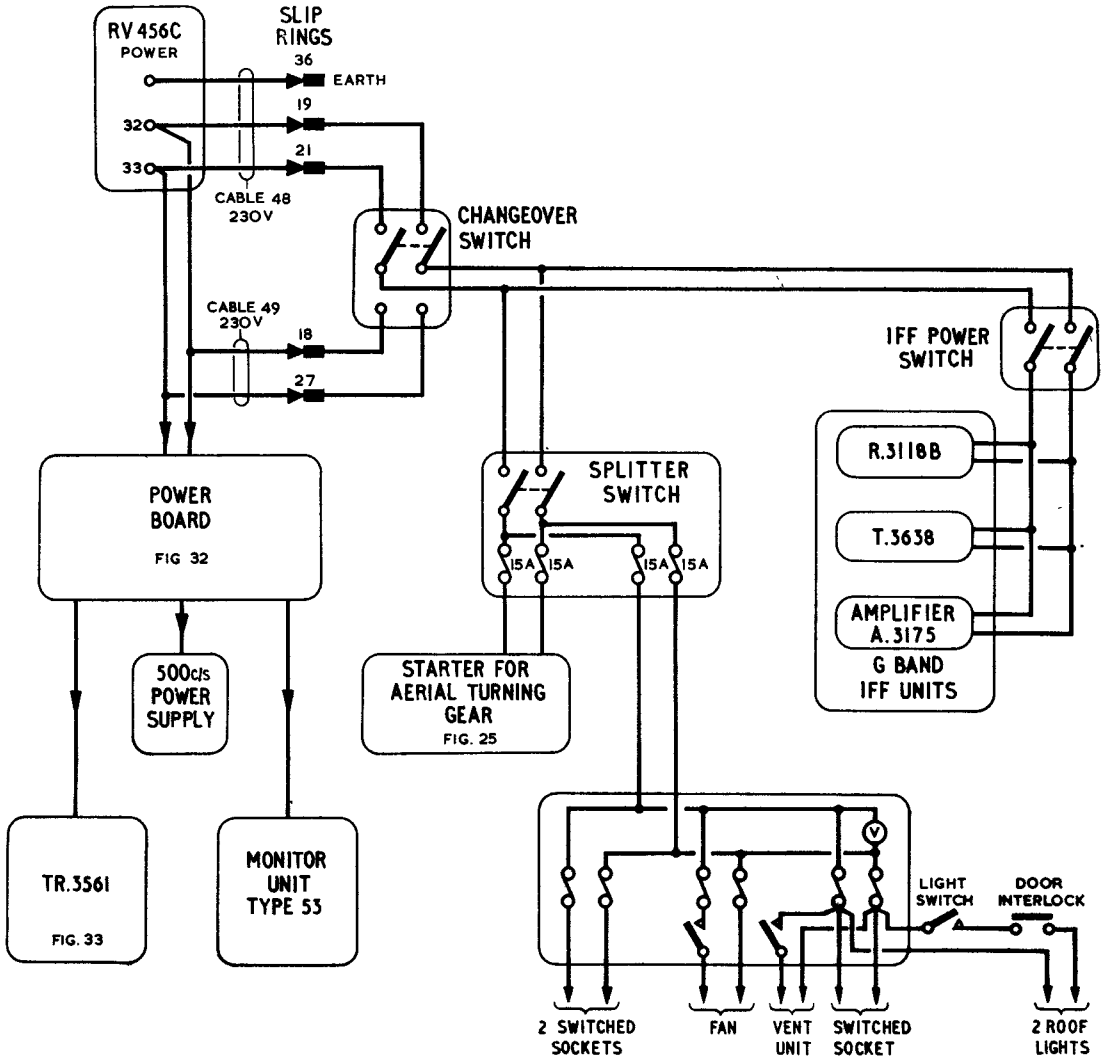

**Fig. 59. 230V AC mains distribution in R.V.461C**

temperature rises and the point is reached where the thermostat contacts open and, as the relay resistance is high compared with that of the heaters, the latter are virtually switched off. The closing of the relay completes the circuit for the blower motor which starts to cool the console.

161. The thermostat in any one of the three consoles may be chosen to regulate the temperature of all, simply by placing the blue/green and blue/yellow tails in the appropriate Jones sockets in the termination box, that is F3 to F11, A3 to A11 or L3 to L11.

**MAINS SUPPLIES**

**General**

162. The distribution of mains supplies throughout the convoy is shown in fig. 59-61.

163. The diagrams need no explanation and should be useful when mains supply faults are experienced. In fig. 61 the fuses referred to are located on the distribution

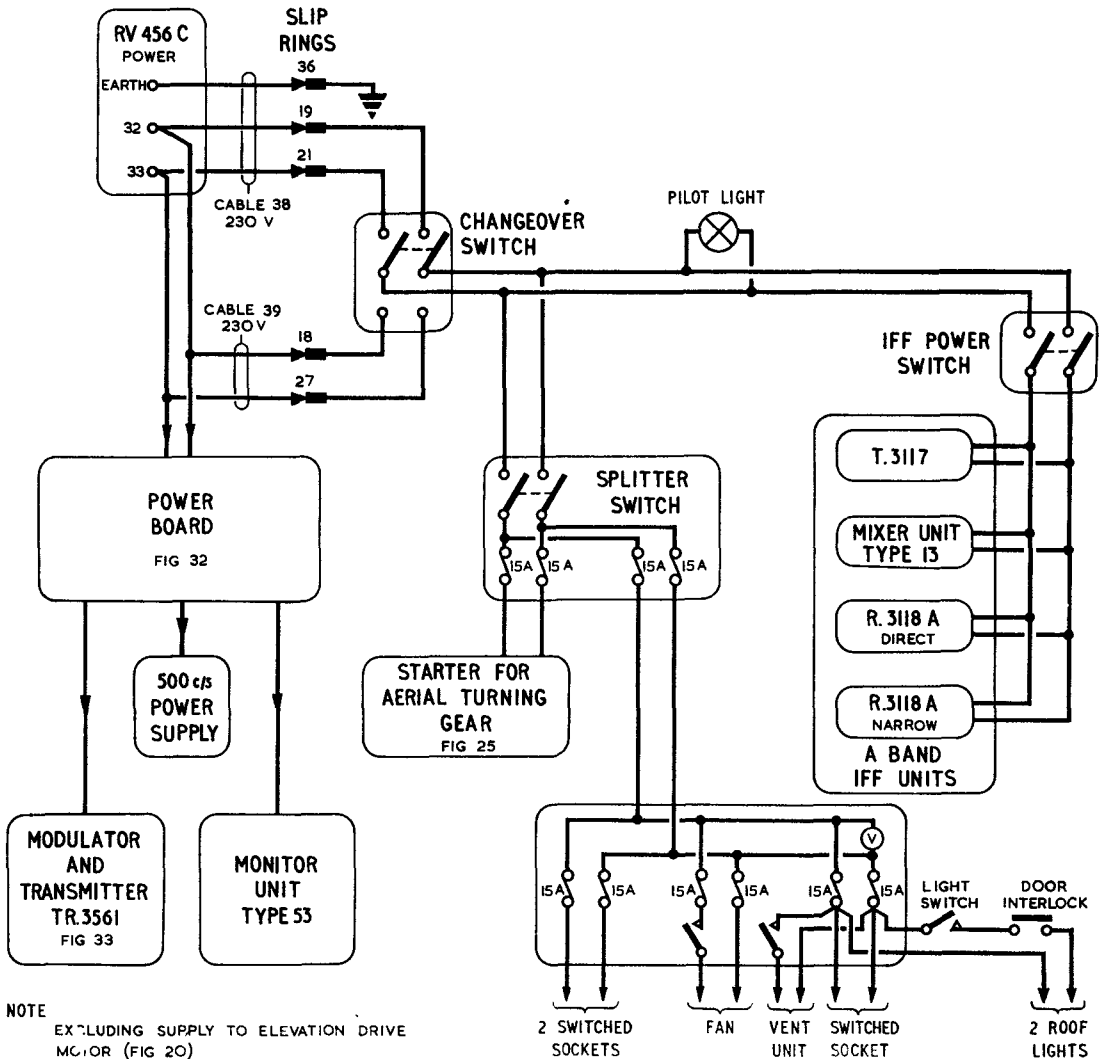

**Fig. 60. 230V AC mains distribution in R.V.462C**

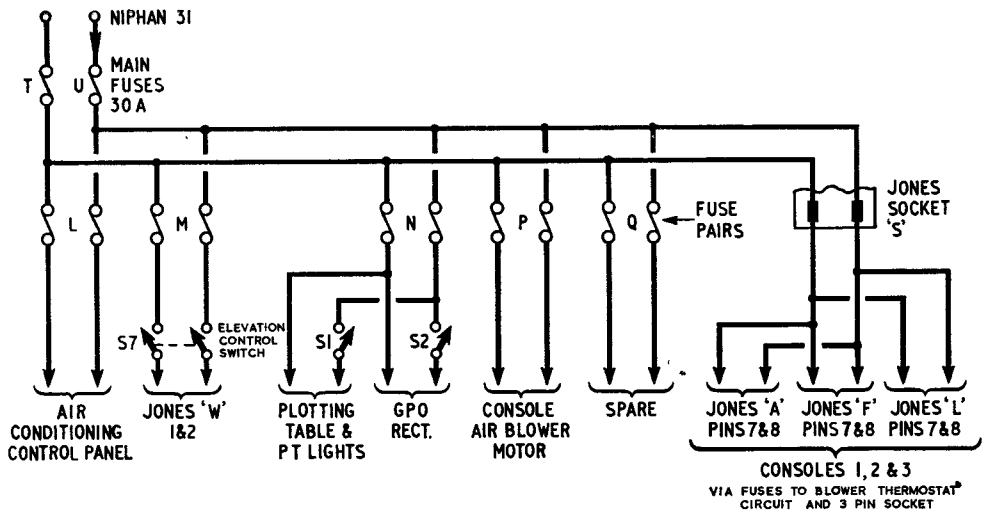

(a) 230 V UNREGULATED CIRCUIT 2

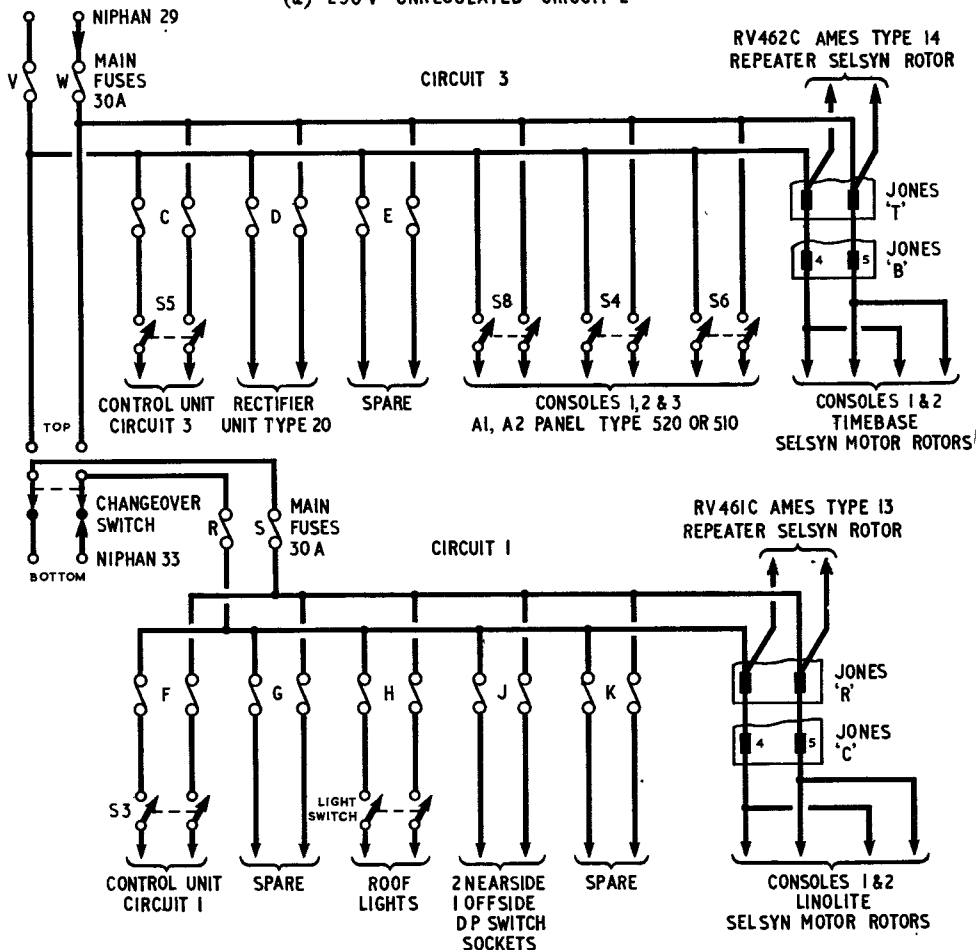

(b) 230 V REGULATED, CIRCUITS 1 & 3

Fig. 61. 230V AC power supply circuits

board. Fuses R-W are rated at 30 amps ; E, J, K, L and O at 15 amps ; C, F, M and P at 10 amps ; A, B, D, G, H and N at 5 amps.

164. It should be noted that fuses A and B are included in the 24V emergency lighting circuit.

## SLIP RING CONNECTIONS

### General

165. The following tables give the connections to the slip rings in AMES Type 13 Mk. 5 and AMES Type 14 Mk. 6. It should be noted that 7 NP means a 7-way niphon plug and 10NS means a 10-way niphon socket.

166. Where there is more than one plug or socket of the same type an identifying qualification has been put in parentheses, for example, 10NS (front). "Front" is the end nearer the driver's cab.

TABLE I  
Slip rings on AMES Type 13 Mk. 5

Slip ring	Service	Termination box		Cable No.
		Plug/Socket	Pin	
1	Lock out to console 3	Pye	37	37
2	} Repeater stator Selsyn rotor Motor stator rotor stator	10NS (front)	1	31
3		do.	4	31
4		do.	2	31
5		do.	5	31
6		do.	3	31
7	A-band IFF lock	Pye	81	81
8	Control selsyn motor stator	10NS	6	32
9	A-band IFF video	Pye	80	80
10	Control selsyn motor stator	10NS	7	32
11		Pye	—	—
12	Control selsyn motor stator	10NS	8	32
13		10NS	1	32
14	230V to aerial tilt motor switch	10NS	2, 3, 9	32
15	Magslip " IN "	2NS (rear)	2	33
16	230V to aerial tilt motor switch	10NS	4, 5, 10	32
17	Magslip " OUT "	2NS (front)	2	34
18	230V AC (with 27 below)	3NP (15 amp.)	3	39
19	230V AC (with 21 below)	3NP (25 amp.)	3	38
20	Telephone	2NS (centre)	2	35
21	230V AC (with 19 above)	3NP (25 amp.)	2	38
22	} Not used			
23				
24				
25				
26		Telephone	2NS (centre)	1
27	230V AC (with 18 above)	3NP (15 amp.)	2	39

TABLE I—contd.

Slip ring	Service	Termination box		Cable No.
		Plug/Socket	Pin	
28	Not used			
29				
30				
31				
32				
33				
34				
35				
36	Earth	—	—	40
Coupling	IF 45 Mc/s	Pye	36	36

TABLE 2  
Slip rings on AMES Type 14 Mk. 6

Slip ring	Service	Termination box		Cable No.
		Plug/Socket	Pin	
1	Lock out to consoles 1 and 2	Pye	47	47
2	50V DC IFF TX switching ....	7NP	3	53
3	Repeater selsyn motor rotor	10NS (front)	4	43
4	IFF G-band video signal ....	7NP	6	53
5	Repeater selsyn motor rotor ....	10NS (front)	5	43
6	IFF G-band remote gain control	7NP	2	53
7	Repeater selsyn motor stator ....	10NS (front)	8	43
8	Control selsyn motor stator ....	10NS	6	44
9	Repeater selsyn motor stator ....	10NS (front)	7	43
10	Control selsyn motor stator ....	10NS	7	44
11	Repeater selsyn motor stator ....	10NS (front)	6	43
12	Control selsyn motor stator ....	10NS	8	44
13	Not used	10NS	1, 9	44
14		10NS	4	44
15		10NS	2, 10	44
16		10NS	5	44
17	IFF A-band lock (not used)	7NP	4	53
18	230V AC (with 27 below) ....	3NP (25 amp.)	3	49
19	230V AC (with 21 below) ....	3NP (15 amp.)	3	48
20	Telephone ....	2NS	Small	45
21	230V AC (with 19 above) ....	3NP (15 amp.)	2	48
22	Not used			
23				
24				
25		10NS	3	44
26	Telephone ....	2NS	Large	45
27	230V AC (with 18 above) ....	3NP (25 amp.)	2	49
28	Not used			
29				
30				
31				
32				
33				
34				
35				
36	Earth	—	—	50
Coupling	IF 45 Mc/s to display units ....	Pye No. 46	—	46

## ANCILLARY EQUIPMENT

### G.P.O. rectifier unit

**167.** Provision for charging batteries is made by the inclusion in the convoy of a G.P.O. rectifier unit Type 246/LU 3185B known as G.P.O. rectifier unit Type 58. A view of the unit is shown in fig. 62.

**168.** The unit works on an input of 200-250V 50 c/s AC and provides an output of 22V at 3A. The input voltage is applied via a switch on the distribution board and two fuses F1 and F2. There is another fuse, F3, in the secondary circuit.

**169.** The charging current can be regulated by altering the position of a slider which has three pre-set tapping positions. The circuit is completed by connections to batteries in a box against the rear wall of R.V.467 below the plotting table.

**170.** Failure of the charging unit is indicated by a buzzer in the telephone switchboard. The operation of the buzzer may be checked by switching off the mains supply at the distribution board.

### Vehicle battery charging unit

**171.** This is auxiliary rectifier unit Type 20. It operates from an input of 200-250V 50 c/s and gives a maximum output of 4A on a battery load of three 12V cells or 6 amp. into a resistive load at 22-28V.

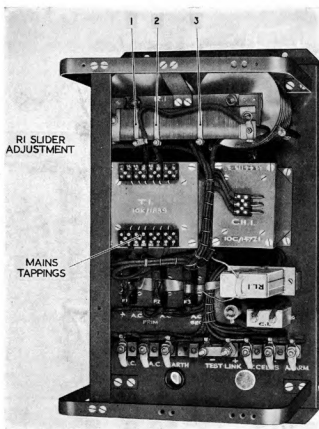
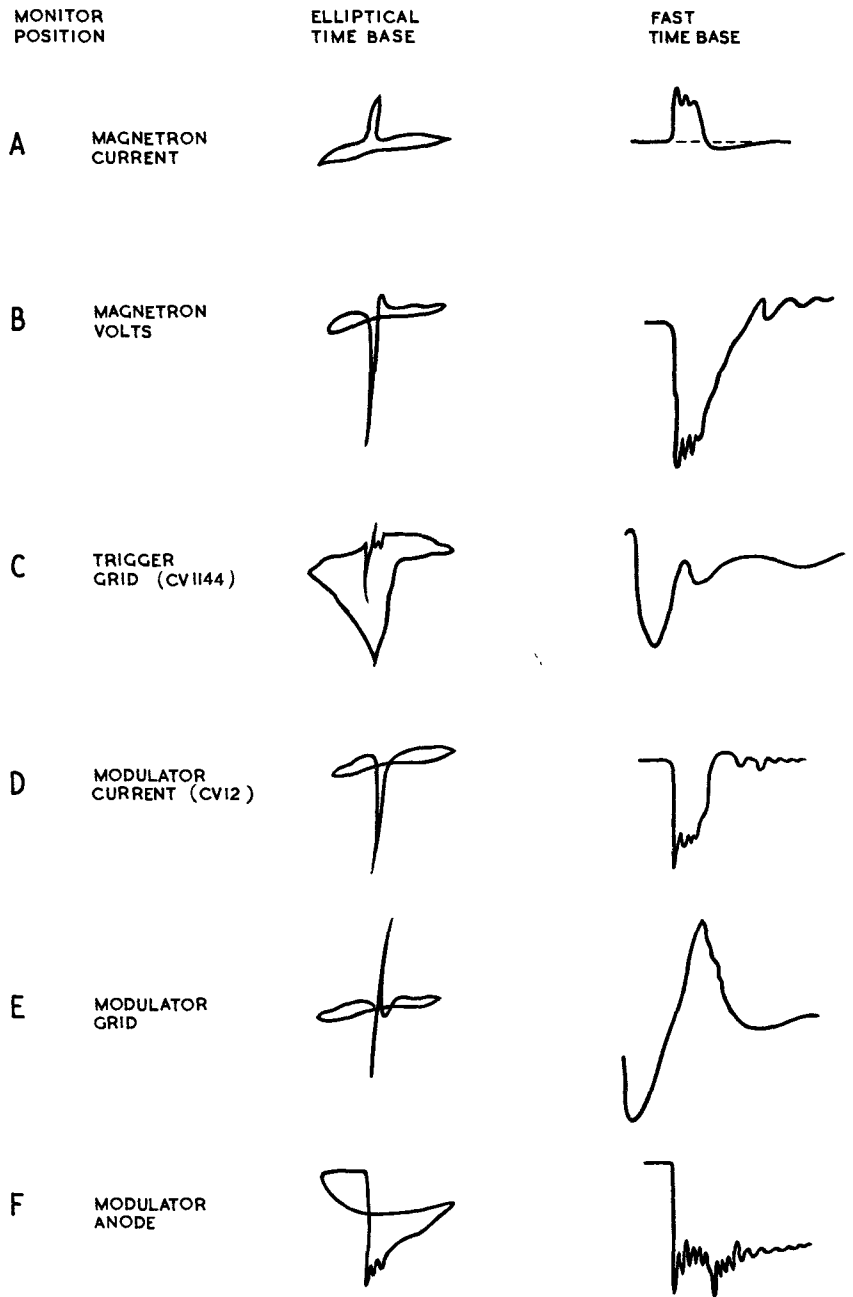

Fig. 62. G.P.O. rectifier unit Type 58

**172.** A circuit diagram of the unit is affixed to the front panel. Fuses are incorporated in input, output and voltmeter circuits.





NOTE — ALL ON LONG PULSE

FIG. 64

TR 3561 WAVEFORMS

FIG 64

ALL CONSOLES

POWER UNIT TYPE  
379(L.P.O)

TEST POINT  
1. V2 ANODE

REMARKS  
LOCAL OSCILLATOR  
SINE WAVE

WAVEFORM



2. V4 ANODE

SQUARE WAVE  
OUTPUT

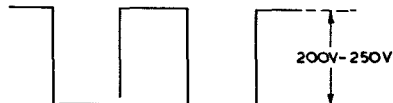

CONSOLE TYPE 15A

PANEL 7  
(T.B.U TYPE 37)

TEST POINT  
1. V2 ANODE

REMARKS  
NEG. FLIP-FLOP  
PULSE

WAVEFORM

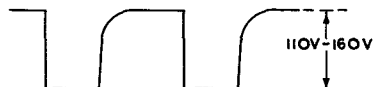

2. V3 ANODE

POSITIVE FLIP-FLOP  
PULSE

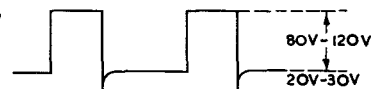

3. V5 ANODE

BRIGHTENER  
PULSE

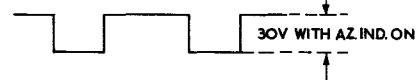

4. V7 ANODE

TIME - BASE  
SWITCHING  
WAVEFORMS

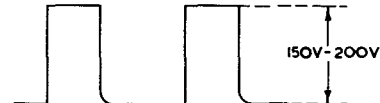

5. V9 ANODE

NEGATIVE  
TIME - BASE

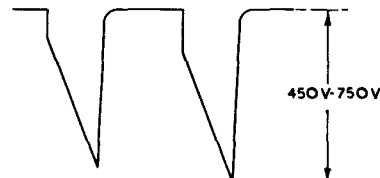

6. V9 GRID

MILLER GRID  
WAVEFORM



FIG. 65A DISPLAY CONSOLE WAVEFORMS

CONSOLE TYPE 15A

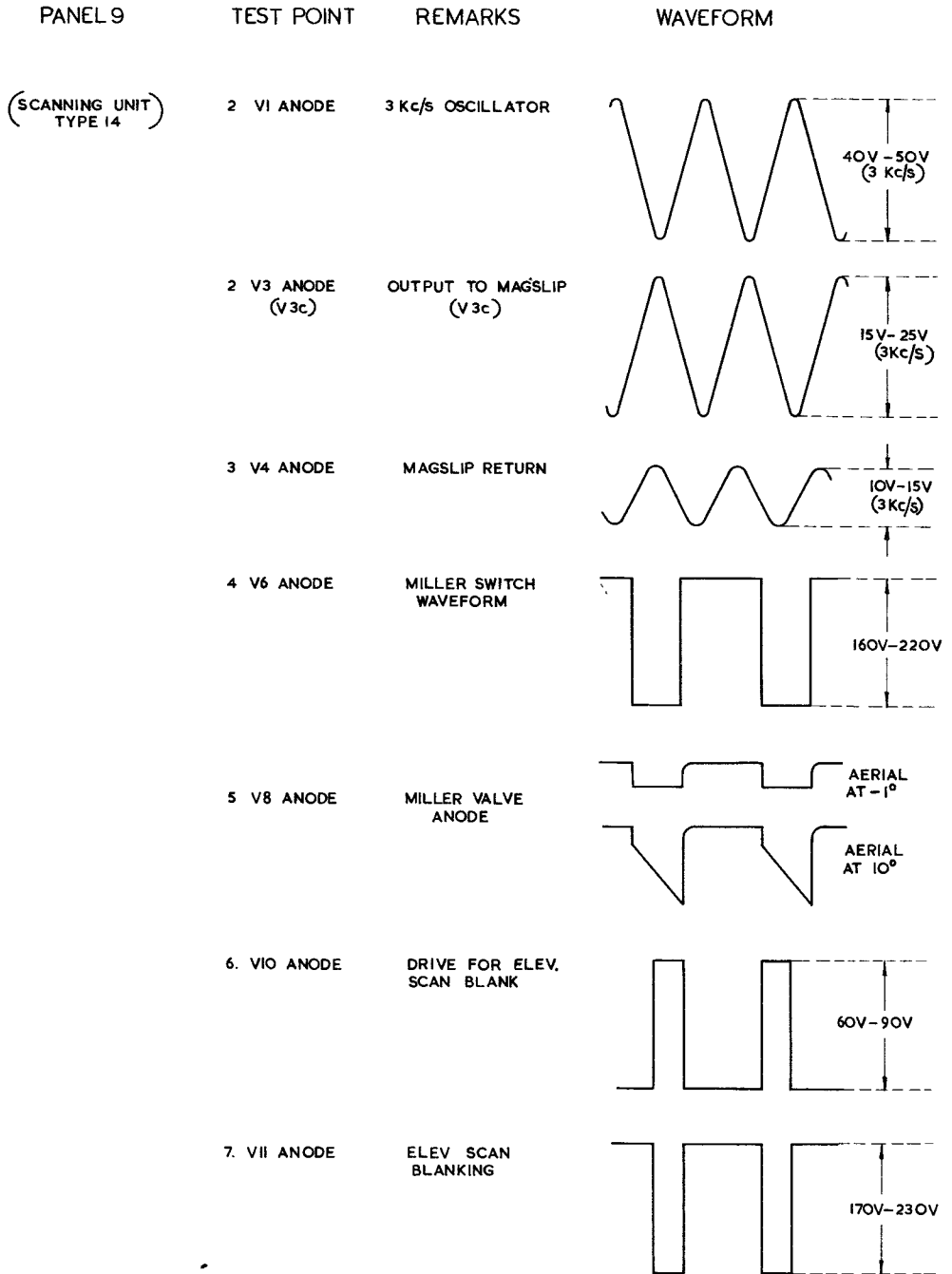

FIG. 65 B DISPLAY CONSOLE WAVEFORMS

CONSOLE TYPE 16 AND 16C

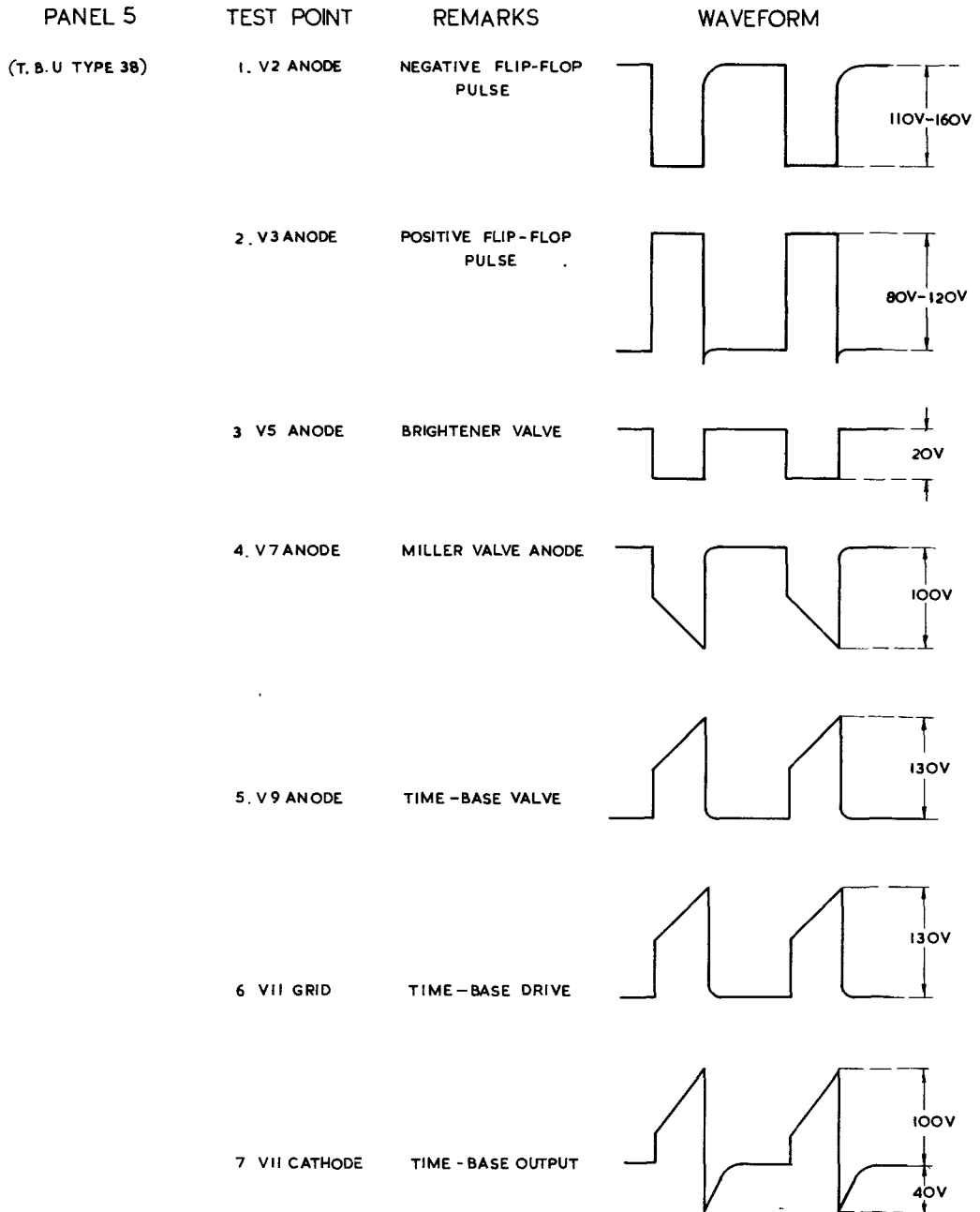

FIG. 65C DISPLAY CONSOLE WAVEFORMS

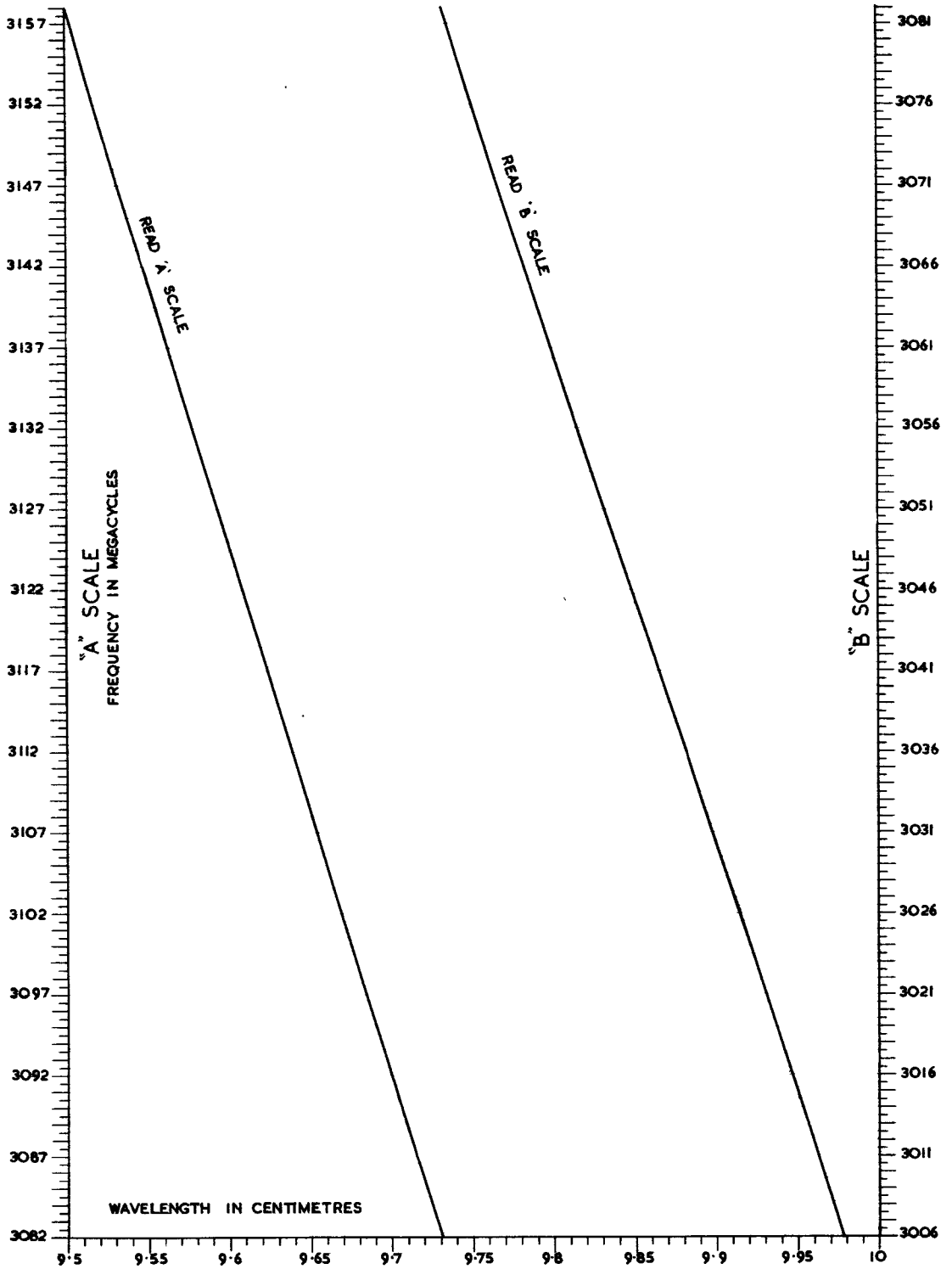

FIG.66 A FREQUENCY-WAVELENGTH CONVERSION CURVE

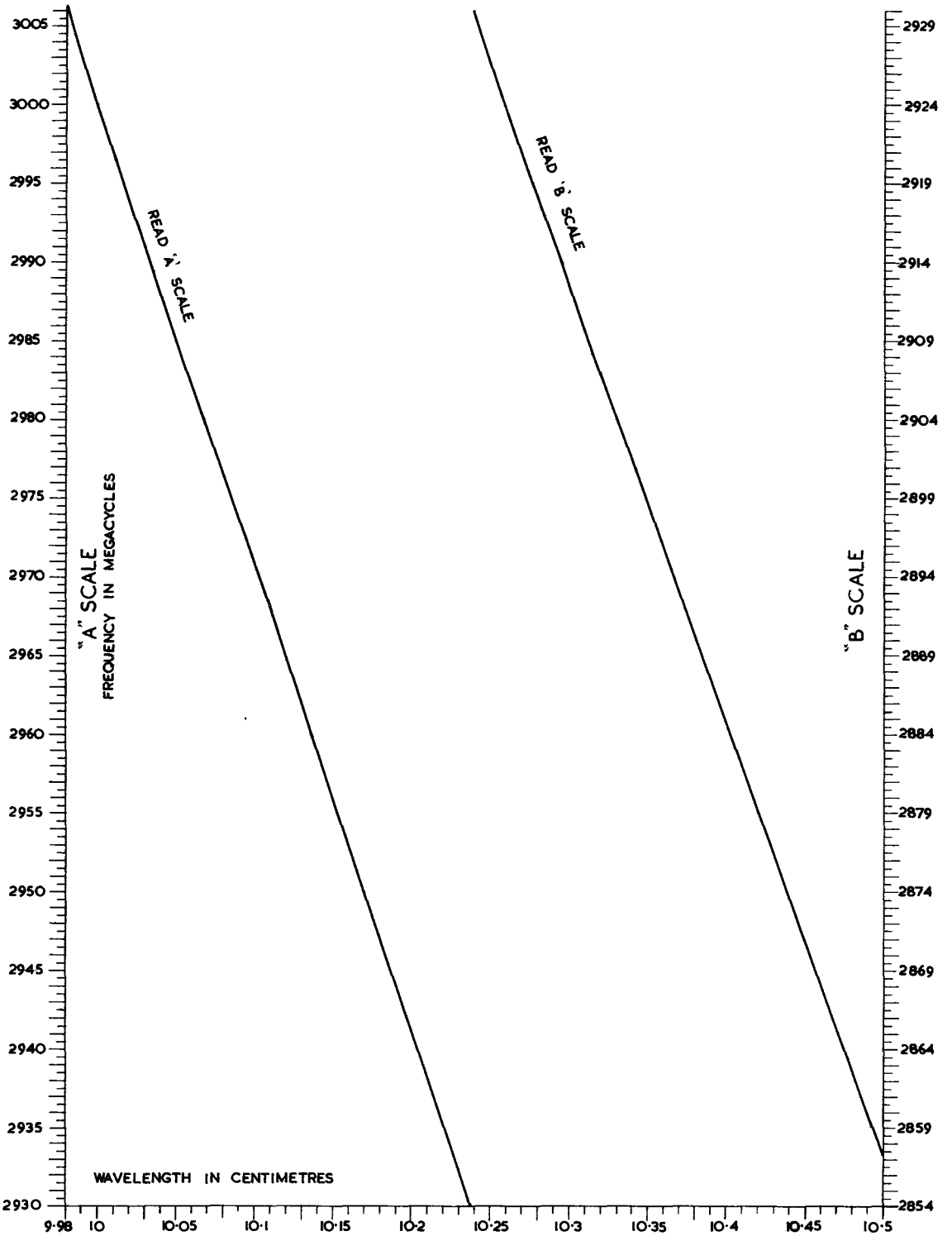

FIG. 66 B FREQUENCY-WAVELENGTH CONVERSION CURVE