

As you are now the owner of this document which should have come to you for free, please consider making a donation of £1 or more for the upkeep of the (Radar) website which holds this document. I give my time for free, but it costs me around £300 a year to bring this document to you. You can donate here <https://blunham.com/Radar>, thank you.

Do not upload this copyright pdf document to any other website. Breaching copyright may result in a criminal conviction and large payment for Royalties.

This document was generated by me, Colin Hinson, from a document held at R.A.F. Henlow Signals Museum which is believed to be out of copyright or Crown Copyright. It is presented here (for free) under the Open Government Licence (O.G.L.) if under Crown Copyright and this version of the document is my copyright (along with the Crown Copyright) in much the same way as a photograph would be. It should be noted that most of the pages are identifiable as having been processed by me. If you believe the original document to be under copyright, please contact me.

The document should have been downloaded from my website <https://blunham.com/Radar>, or any mirror site named on that site. If you downloaded it from elsewhere, please let me know (particularly if you were charged for it). You can contact me via my Genuki email page: <https://www.genuki.org.uk/big/eng/YKS/various?recipient=colin>

You may not copy the file for onward transmission of the data nor attempt to make monetary gain by the use of these files. If you want someone else to have a copy of the file, point them at the website (<https://blunham.com/Radar>). Please do not point them at the file itself as it may move or the site may be updated.

I put a lot of time into producing these files which is why you are met with this page when you open the file.

In order to generate this file, I need to scan the pages, split the double pages and remove any edge marks such as punch holes, clean up the pages, set the relevant pages to be all the same size and alignment. I then run Omnipage (OCR) to generate the searchable text and then generate the pdf file.

Hopefully after all that, I end up with a presentable file. If you find missing pages, pages in the wrong order, anything else wrong with the file or simply want to make a comment, please drop me a line (see above).

If you find the file(s) of use to you, you might like to make a donation for the upkeep of the website – see <https://blunham.com/Radar> for a link to do so.

Colin Hinson

In the village of Blunham, Bedfordshire, UK.

AIR PUBLICATION

116L-0409-16

**TAPE READER, ELLIOTT TYPE
TRM 500-93 AND TRM1000-95**

GENERAL AND TECHNICAL INFORMATION

BY COMMAND OF THE DEFENCE COUNCIL

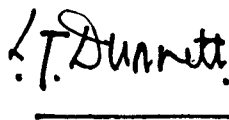
A handwritten signature in black ink, appearing to read 'J. Dunnett', is written above a horizontal line.

Ministry of Defence

FOR USE IN THE

ROYAL AIR FORCE

(Prepared by the Ministry of Technology)

**International
Computers
Limited**

**Technical
Manual**

ICL

**TRM 500-93
TRM 1000-95
Tape Readers**

With effect from 9th July, 1968 the name
of International Computers and Tabulators
Limited has been changed to
International Computers Limited.

© International Computers Limited 1969

First Edition August 1967

Reprinted August 1970

Issued by Design Communication
International Computers Limited,
Head Office: ICL House, Putney,
London SW15.

Printed in Great Britain

CONTENTS

	Page
Chapter 1: GENERAL DESCRIPTION	
1.1 Introduction	1
1.2 Brief Description of Major Units	2
1.3 General Technical Data	3
Chapter 2: PRINCIPLES OF OPERATION	
2.1 Tape Drive	7
2.2 Clutch and Brake	7
2.3 Clutch and Brake Control	8
2.4 Sensing System	8
2.5 Speeds	8
Chapter 3: INSTALLATION AND OPERATION	
3.1 External Connections	11
3.2 Tape Loading	11
3.3 Starting	12
3.4 Tape Run-Out	12
3.5 Braking	12
3.6 Tape Splicing	12
Chapter 4: DISMANTLING, ASSEMBLY AND ADJUSTMENT (MECHANICAL)	
4.1 Top Cover Removal	15
4.2 Side Cover Removal	15
4.3 Base Cover and Circuit Board Removal	15
4.4 Lamp Removal and Adjustments	15
4.5 Prism Removal and Adjustments	16
4.6 Brake Armature Removal	17
4.7 Machine Table Removal	17
4.8 Brake Assembly Removal and Adjustments	18

	Page
Chapter 8: PARTS LIST..	41
APPENDIX 1: Use of Clutch Roller/Spindle Set	1

ILLUSTRATIONS

	Fig.
Typical Tape and Output Waveforms	1
Circuit Board - Component Layout (TRM 500-93).. . . .	2
TRM 500-93 Circuit Diagram	3
Circuit Board - Component Layout (TRM 1000-95)	4
TRM 1000-95 Circuit Diagram	5
Illustrated Parts List	6

Chapter 1: GENERAL

1.1 Introduction

Elliott High Speed Tape Readers are precision electro-mechanical instruments designed to provide high speed inputs for computers and processors. They will read, photo-electrically, 5, 6, 7 and 8 hole punched paper tapes of any colour and will operate at any speed up to their rated maximum. The rated maximum speeds are nominally, for TRM 1000-95 readers, 1,000 characters per second and for TRM 500-93 readers, 500 characters per second.

The readers are free standing and compact with high reliability, long life and accuracy which are ensured by selecting components to work well within their rating. Each reader is of simple robust construction with the minimum number of moving parts which are tested for long runs throughout its speed range, which in the case of TRM 1000-95 readers, amounts to the reading of several million characters without error.

The tape is drawn through the brake mechanism and over the photo-electric reading station by a capstan against which the tape is pressed by the pinch rollers of the clutch mechanism. Both the clutch and brake mechanisms are operated by electromagnets. By the use of the electro-magnetically operated braking system, high speed braking is achieved and the tape will come to rest within the character. The capstan is fitted to the shaft of a continuously running motor and the movement of the pinch roller is sufficient to permit the passage of a tape splice and to avoid driving on a splice when the clutch is disengaged.

Cooling is by a fan mounted on the rear end of the motor shaft. The fan draws air through the reader to ensure that components do not exceed their working temperature range.

By the use of silicon photo-voltaic cells in carefully designed circuits the reader will operate over an ambient temperature range of -10°C to $+45^{\circ}\text{C}$.

Each reader forms a self-contained unit comprising of motor, clutch and brake assemblies, a complete optical system, a photovoltaic reading head assembly and a data amplifier board.

1.2 Brief Description of Major Units

The reader consists of the following functional units.

Motor Assembly - This consists of a F. H. P. Motor having a special rigid shaft on which is mounted the tape drive capstan at the front and the fan at the rear.

Clutch Assembly - This consists of the clutch coils, armature, clutch (pinch) roller bracket assembly, clutch roller bracket pivot and return spring, all mounted on a cast aluminium alloy bracket.

Brake Bracket Assembly - This consists of the brake coils, armature, brake pads, damping pad and pressure spring mounted on a cast aluminium alloy bracket.

Tape Width Selector Assembly - This consists of the guide pin lever, microswitch actuating arm, return spring, pressure bar, tape width selector arms and guide pins.

Top Plate Assembly - This includes a polished chromium top plate, glass window, polished perspex tape guide, and guide rollers.

Reading Head Assembly - This is a replaceable unit consisting of terminal plate, head supports, retainer, slotted retainer and photovoltaic cells.

Lamp and Prism Assembly - This consists of the mounting bracket, lamp retaining plate, lamp contact, contact post and a 12V 48 w prefocus lamp and prism.

Circuit Board - This board incorporates transistorized data amplifiers, amplifier control and data output control circuits.

1.3 General Technical Data

Tape Widths

Will accept any standard width of tape, up to one inch, punched with sprocket holes and up to eight data channels.

Tape Quality

Any tape conforming to B. S. 3880, Waterlow Tape Type A1 is recommended. This tape is manufactured by:-

Waterlow and Sons Limited,
Paper Converting Division,
85/86, London Wall,
London, E. C. 2.

Speed of Operation

Model TRM 500/93 up to 500 characters per second and model TRM 1000/95 up to 1000 characters per second.

Output Signals

Polarity:

Logic '0': $-0.2V \pm 0.2V$

Logic '1': V volts on open circuit, where V is the negative voltage applied to PL2, pin M (TRM 500-93) and PL1 pin N (TRM 1000-95)

No. of channels: Nine, maximum.

Power Requirements

Assembly	Voltage	Current	Max. Ripple
Motor	200-250V, 50 c/s \pm 2 c/s	500 mA	-
Lamp	9.5V a.c./d.c.	3.5 A	-
Clutch	-20V d.c.	1 A	2V p-p
Brake	-20V d.c.	1 A	2V p-p

Clutch Coil Impedance

0.5 (resistive) and 16 mH

Brake Coil Impedance

0.5 (resistive) and 18 mH

Connectors

Plessey Mk. 4 12-way and 18-way connectors.

Overall Dimensions

Height	Width	Depth
9 ³ / ₄ in. (24.8cm)	6 in. (15.2cm)	9 in. (22.8cm)

Weight

18 lb (8.2Kg) approx.

Temperature Range

+5°C to +45°C.

Humidity Range

40% to 90% R. H.

Chapter 2: PRINCIPLES OF OPERATION

2.1 Tape Drive

The drive motor is a split-phase induction motor, which runs just below synchronous speed with a small amount of slip which will vary with load. The capacitor which supplies the phase shift winding is chosen to give the required torque-speed characteristic and is permanently connected and mounted in the reader case.

On the outer end of the motor spindle is a drive capstan of hardened steel, ground concentric with the axis of rotation. At the other end of the motor spindle, inside the case, is a fan which draws a current of air through the reader and out at the back, thus providing cooling for the motor and circuit boards.

2.2 Clutch and Brake

These are both operated by electromagnets and together control the movement of the tape. When the clutch magnet is energised the tape is pressed against the continuously rotating capstan by the clutch rollers and the brake is off; when the clutch is off the brake is on and the tape will stop within the character.

The clutch and brake are positioned on opposite sides of the window set in the top plate so that as the tape is drawn over the window it is kept flat by the slight remaining pressure left on the brake.

The clutch rollers are positioned immediately below the capstan roller so that the tape line is not disturbed when the clutch is engaged. When the clutch is released there is sufficient clearance between the clutch rollers and the capstan to avoid driving on a splice.

2.3 Clutch and Brake Control

An external circuit using transistors, should be devised to give rapid operation of the clutch and brake from small signals. Much of the success of these readers in maintaining control of the tape for rapid starting and stopping depends upon the design of the control circuit.

2.4 Sensing System

This consists, from light source to data output, of a 12V 48 watt pre-focus lamp, a combined lens and prism, photovoltaic cells in an assembly below the top plate and a circuit board.

Light which passes through holes in the tape and the optical mask of the reader generates a rounded waveform in the photosensors. Squaring of these signals is carried out in the transistorized amplifier which is considerably overdriven. Some variation of the effective mark/space ratio is obtainable by adjustment of the base bias on the transistors of the amplifier. This is achieved by adjusting RV1 a-j. Output signals are negative going pulses of an amplitude nominally the same as the negative rail of the amplifiers.

2.5 Speeds

The maximum speeds available depend upon the size of the capstan and the speed of the motor and are approximately 500 characters per second for the TRM 500-93, and 1,000 characters per second for the TRM 1000-95 readers.

Under conditions of maximum speed the tape runs continuously. For speeds lower than this the drive circuit will be disengaged intermittently for part of the cycle of reading. For speeds up to about 350 characters per second, the tape will come to rest between characters. In all cases, unless

another 'read' signal is applied, the tape will stop within the space of a character. During acceleration of the tape until it reaches maximum speed, there is slip on the capstan. During deceleration the tape is not pressed against the capstan, but the brake is applied and the tape slips until it comes to rest.

Operation of the brake assembly will give stopping times of 0.6 milliseconds from 1,000 characters per second and 0.3 milliseconds from 500 characters per second.

Chapter 3: INSTALLATION AND OPERATION

3.1 External Connections

Supplies to and outputs from the reader are by means of a 12-way and an 18-way Plessey plug. These supplies can be listed as two different sections, data supplies and outputs (12-way) and reader control through the 18-way.

Connections are as follows:-

12-way (PL2)		18-way (PL1)		
Item	Connection	Item	Connection	
Data 1	0-1	Brake (1A. -20V)	C)) TRM 500-9
Data 2	0-2	Clutch(1A. -20V)	A)	
Data 3	0-3	Brake/Clutch (0V)	B)	
Spkt 4	0-4	Brake (1A. -20V)	C & O)) TRM 1000
Data 5	0-5	Clutch (1A. -20V)	A & B)	
Data 6	0-6	Run-out Switch	D	
Data 7	0-7	Run-out Switch	J	
Data 8	0-8	Front Switch (PB)	E	
Data 9	0-9	Front Switch (PB)	F	
+10V		Rear Switch (PB)	K	
-10V		Rear Switch (PB)	L	
0V		-20V (Data Control)	N	
		Chassis Earth	P	
		Lamp (9.5V)	R	
		Motor	Q	
		Motor	S	

3.2 Tape Loading

First adjust the pressel bar to the required tape width then

depress the bar and slip the tape into position edgeways from the front of the machine.

3.3 Starting

An ON/OFF switch situated on the front of the machine operates the motor and lamp.

3.4 Tape Run-out

To run through unrequired sections of tape press the button on the front of the machine; the run-out function is controlled by external logic.

3.5 Braking

This is achieved automatically, the signals being derived from the sprocket signal. The clutch and brake may be de-energized simultaneously by depressing the pressel bar. This action is controlled by external logic.

3.6 Tape Splicing

The exact procedure to be followed for tape splicing is not critical if a few essential facts are borne in mind.

Adhesive splicing tape, such as opaque black Sellotape, should be approximately 0.003 in. thick but not more, otherwise there may be difficulties due to excessive thickness of the join. For this reason butt-splices are always used.

It is most important that holes which become obscured by adhesive tape should be cleared before the spliced tape is used or there will be danger of false readings.

Two main types of splicing have to be considered - simple joining of tapes or repairing a tear.

Slight reduction of sprocket-hole spacing at the join has been found to give less trouble than increased spacing, though the aim should be to maintain sprocket-hole spacing uniform through the join.

For a simple join a suitable procedure would be as follows:-

- (a) Overlap the two ends of the tape and align the sprocket-holes.
- (b) Cut through the double thickness of tape with a sharp blade.
- (c) Remove the loose end from the top.
- (d) Apply a strip of adhesive tape across the butt ends of the main tape without change of position of the cut ends.
- (e) Trim the ends of the adhesive tape with a sharp blade so that they do not protrude beyond the edges of the main tape.
- (f) Holes obscured by the tape must be completely cleared before the tape is used.

For joining a tear, without loss of any data, the ends must be butted so that uniform sprocket-hole spacing is maintained, and especial care must be taken over item (f) above. No light should pass through the join.

Normally, when joining tape away from punched data, a diagonal splice is preferred for smooth running of the tape. On occasions

TRM 500-93
TRM 1000-95

when a diagonal splice would interfere with punched data, a right-angle splice may be necessary.

Chapter 4: DISMANTLING, ASSEMBLY AND ADJUSTMENTS. MECHANICAL

4.1 Top Cover Removal

Remove the instrument head screws securing the top cover to the side cover. The cover can now be removed by tilting it towards the front of the machine and gently withdrawing it, taking care not to damage the light prism.

4.2 Side Cover Removal

Remove the five 6 BA round head screws from the side covers. The reader can now be lifted clear of the cover.

4.3 Base Cover and Circuit Board Removal

Remove the four 4 BA cheese-head screws which hold the rubber feet in position. The base cover can now be removed. To remove the circuit board unscrew the four spacers which clamp the board to the base then lift off and swing the board clear. Re-assemble in the reverse order.

4.4 Lamp Removal and Adjustments

Slacken the 4 BA cheese-head screw holding down the centre contact for the lamp. Swing the contact clear of the lamp and slacken off the lamp securing plate, the lamp can now be removed from the lamp holder.

Thoroughly clean the replacement lamp and place it in position in the lamp holder. The filament support should be directed towards the rear of the machine. Replace the lamp contact, switch on the machine and adjust the lamp by turning it within the lamp holder until the correct intensity, distribution and displacement of light pattern is obtained (see section 4.5 for full description of the method). Tighten the lamp locking screw and ensure that the lamp contact retaining screw is tight.

4.5 Prism Removal and Adjustments

Using the procedure described in section 4.4 remove the lamp from its holder. Remove the two 6 BA cheese-head screws and washers which secure the prism to the prism locating bracket. The prism can now be removed by withdrawal towards the rear of the machine.

Ensure that the replacement prism is not damaged in any way, taking particular note that no abrasions are present on any of the prism faces. Position the prism in the prism locating bracket and secure it with the two 6 BA screws and washers.

To adjust the prism, slacken the two 4 BA screws and nuts which clamp the lamp holder bracket to the mounting bracket. Mark two lines 0.01 in. apart squarely across a piece of 1 in. wide tape. Place this tape in the machine and position it so that the two lines are evenly distributed along the length of the read head.

Check that the lamp voltage is 9.5 volts at the lamp contacts. Any adjustments must be made to the supply, which is external to the reader.

Adjust both the lamp and prism positions to obtain a patch of light of maximum intensity within and parallel to the lines marked on the piece of paper tape. This illuminated area must cover the whole width of the tape. Then tighten the 4BA screws and nuts and tighten the lamp retaining screw.

Care must be taken that the light pattern does not alter its position whilst tightening these screws.

4.6 Brake Armature Removal

Remove the top cover (4.1) then remove the two 4 BA socket cap screws which secure the armature assembly to the machine table. Remove the assembly. If any part of the assembly needs to be renewed ensure that the new parts are free on the two brass locating pins. The order of re-assembly is:-

- (1) Armature (ensure that the side with the radiused edge is offered to the brake pad).
- (2) Foam rubber pad
- (3) Pressure plate
- (4) Pressure spring
- (5) Armature locating bracket

The pressure spring adjusting screw is locked by a dome-headed lock nut. Residual brake pressure is adjusted by turning this screw and is used as a fine control of maximum tape speed. For initial setting-up the friction drag on the tape is 50 grams \pm 5 grams.

4.7 Machine Table Removal

Remove the two 6 BA screws and collect the capstan guard. Remove the four 6 BA chrome-plated instrument-head screws at each corner of the machine table. Withdraw the pressel bar to the maximum tape width position. Depress the pressel bar to its fullest extent. The machine table can now be removed by lifting the front edge clear of the dowel pins and sliding it towards the front of the machine and tilting it upwards. There is no adjustment to the table as it is correctly located by means of the four instrument-head screws.

Re-assemble in the reverse order.

4.8 Brake Assembly Removal and Adjustment

First remove the top cover (4.1), base cover and circuit board (4.3) and the machine table (4.7).

Remove the four 4 BA screws holding the brake coil assembly, the assembly can now be lifted clear of the machine. When the assembly is clear of the machine unsolder the cable leads from the tagboard. Replacement brake assemblies are supplied complete, without the armature assembly. Re-assemble in the reverse order.

4.9 Brake Pad Removal

Remove the 6 BA countersunk screw holding the brake pad to the assembly casting then remove the pad. Usually a number of coloured plastic shims will be under the brake pad, ensure that these shims are retained and are correctly re-assembled.

4.10 Brake Force Adjustments

Before attempting to adjust the brake force ensure that the brake pad is not damaged in any way and that the securing screw slot is not burred and does not obstruct the tape passage.

The following items will be required to carry out the brake adjustments:-

- (1) A length of unperforated tape approximately 18 in. long
- (2) Brake and Clutch Test Tape Clamp (1(2/4)A120212)
- (3) An accurate spring gauge such as a 2 to 100 gramme gauge.

When the brake is energised and there is no tape in the reader, the gap between each poleface and the armature should be 0.0015 in. to 0.0025 in. The two gaps should not differ by more than 0.0005 in., and may be set correctly by placing the appropriate number of shims under the brake pad.

With the clutch and brake released, the force required to keep an unperforated 1 in. wide length of paper tape just moving forwards through the reader must not be less than 45 gm and not more than 55 gm. To check the brake force, insert a length of unperforated tape into the reader. Secure the left-hand end (viewed from the front of the reader) to the spring gauge using the test clamp(1(2/4)A120212). Release the brake and clutch. Draw the tape slowly forwards through the reader, taking care to keep the gauge arm at right angles to the tape and the tape horizontal.

Check that the force required to keep the tape just moving lies within the limits given above.

4.11 Clutch Assembly Removal

First remove the top cover (4.1), side cover (4.2), base cover and circuit board (4.3) capstan guard and the machine table (4.7).

Now unhook the pressel bar return spring from its anchor pin on the front right-hand edge of the machine casting, unscrew the two 4 BA nuts at the ends of the pressel bar, and remove the two locating screws. The pressel bar assembly can now be withdrawn complete from the machine.

Take out the four 4 BA screws securing the clutch assembly to the machine. The assembly can now be withdrawn from the machine, then unsolder the cable leads from the tagboard to release the assembly.

4.12 Clutch Roller Bracket Assembly Removal

First remove the two 6 BA cheese-head screws securing the armature. This is now removed complete with brass shims. The two locknuts are now unscrewed from the spring anchor pin, the assembly can now be removed. Re-assemble in reverse order.

4.13 Clutch Assembly Adjustments

Fit the clutch roller bracket assembly to the coil assembly then attach the two locknuts to the spring anchor pin. Ensure that the screws securing the roller bracket pivot to the roller bracket are tight. Slacken the locking screw on the split arm containing the roller bracket adjusting screw. As a preliminary adjustment set the lower face of the bracket directly under the clutch roller spindle until it is 90° to the vertical face of the clutch coil casting. This condition is achieved by means of the roller bracket adjusting screw. Using an accurate spring gauge, a Salter 32 oz. push/pull type is recommended, place the gauge arm on the armature end of the roller bracket and set the pressure of the return spring to 22 oz. \pm 2 oz. by means of the adjusting nuts. The 90° angle referred to above should remain unchanged.

Place the coil assembly into the machine. Position the assembly so that the centre line of the roller spindle is directly underneath the centre line of the drive capstan.

Place a true flat surface against the capstan and line up the clutch roller assembly until the clutch rollers are completely parallel to the capstan roller length. Tighten the clutch assembly screws.

Adjust the gap between the capstan and the clutch rollers to 0.0065 in. by means of the roller bracket adjusting screw. This gap must not vary by more than 0.0005 in. over the roller length. If it does, refer to motor adjustments (4.19).

Place a 0.003 in. feeler gauge between the capstan and the clutch rollers. Actuate the clutch rollers by placing a finger at either end of the armature and depressing it until the 0.003 in. feeler is nipped. In this position there should be a gap of 0.008 in. to 0.012 in. between the armature and the polefaces of the magnets. To obtain this condition insert shims between the armature and the coil bracket.

The pinch roller travel limiting stops should be adjusted so that when the clutch is energised, a gap between the pinch roller and the capstan is present. This gap must not be greater than 0.002 in. Both travel limiting stops should touch their pole pieces at the same time.

4.14 Clutch Force Adjustments

Remove the brake armature as in 4.6 to avoid the effect of brake drag on the clutch force measurement. Adjust the clutch operating current to 1.0 amp. for this measurement. Insert a length of unperforated tape as in section 4.10, with the test tape clamp on the right. With the clamp held by hand, to prevent it being fed into the reader, switch on.

Measure the tape drive force with a Correx 50 to 500 gramme gauge placed in the loop of the tape clamp. This force should be 275 grammes \pm 25 grammes and is the minimum force required to keep the unperforated tape just moving backwards against the capstan drive.

To reduce the clutch force, reduce the number of shims between the armature and the clutch lever to which it is attached. To increase the force, increase the number of shims. One shim alters the force approximately 50 grammes. Fine adjustment is possible by slackening the two armature securing screws and moving the armature towards or away from the pivot.

NOTE: For correct operation the ratio of brake to clutch force should be maintained near the average value. If the brake force is near one extreme limit the clutch force should be near the corresponding limit. If the brake is adjusted then the clutch should also be adjusted and vice versa.

4.15 Read Head Assembly Removal

Remove the base cover and circuit board from under the base of the machine (4.3), taking care not to damage the cables which are still attached to the read head. Take out the four 6 BA cheese-head screws securing the read head assembly to the machine casting. The read head can now be withdrawn. Re-assemble in the reverse order.

4.16 Read Head Assembly Adjustment

Remove the base cover and circuit board as in 4.3. Slacken the four 6 BA cheese-head screws securing the read head assembly to the casting, loosen the two eccentric washers which position the terminal plate of the assembly.

Withdraw the pressel bar to the 1 in. tape position. Place the read head setting gauge (T477) in position on the top plate and move the read head assembly until data holes seven and nine are in line with the holes in the gauge.

This assembly can only be adjusted in a line parallel to the line of the read head. There is no lateral adjustment.

When the assembly is in position tighten the two eccentric washers to clamp the assembly then tighten the four 6 BA screws in the terminal plate.

Care must be taken that the assembly does not move while tightening the eccentric washers nor while tightening the terminal plate screws.

4.17 Replacement of Photosensors

- CAUTION:
1. THE PHOTSENSORS ARE SUPPLIED COMPLETE WITH LEADS. DO NOT APPLY A SOLDERING IRON DIRECT TO THE CONNECTIONS ON THE BASE OF THE SENSOR.
 2. THE READING HEAD MUST NOT BE DISMANTLED BEYOND THE REMOVAL OF THE COLLIMATOR BLOCK, PHOTO-SENSOR RETAINER AND PHOTOSENSORS. THE POSITIONS OF OTHER PARTS MUST NOT BE DISTURBED.

Detach the reading head as detailed in para.4.15. Unsolder the signal lead of the faulty photosensor from the tagstrip, and remove the sleeve. Cut the other lead, supplying the bias voltage, just below the connection on the base of the sensor. Withdraw the lead downwards through the sleeve containing the bias leads to the other sensors and cut it from the tag on the tagstrip. Take care that no other connections are disturbed.

Remove the two screws which secure the tufnol photosensor retainer. It may be necessary to remove the collimator block in order to reach the screws holding the retainer. To release the collimator block, remove the two countersunk screws in the top surface. Note which way round the collimator block is fitted. It must not be reversed on re-assembly. DO NOT DISTURB ANY OTHER SCREWS OR PARTS OF THE READING HEAD.

NOTE: When the collimator block securing screws are removed, IT IS ABSOLUTELY ESSENTIAL THAT THE SUPPORTING PILLARS ARE HELD SECURELY to prevent any rotation and consequent loss of adjustment. If the position of either pillar is disturbed, it will be impossible to replace the collimator block in the correct position without resetting the complete assembly.

When the collimator block securing screws have been removed, ease the block sideways away from the support pillars, taking care not to place any strain on the connecting leads to the sensors. The two screws securing the photosensor retainer may then be removed, and the retainer eased sideways from under the collimator block. The sensors will remain attached to the retainer. Remove the faulty sensor, and insert a new sensor by feeding the leads through the two holes in the retainer. Take care to insert the sensor the correct way round, so that the positive pin on the base is in the line with the positive pins on the other sensors. Replace the retainer under the collimator block, and replace the two securing screws. Feed the leads through their respective sleeves, one of which was removed from the faulty sensor, and solder to the appropriate points on the tagstrip.

4.18 Photosensor Outputs

After replacement of a photosensor, the output of a new sensor should be checked. If either the lamp or prism has been re-adjusted, or the lamp, prism or mask has been replaced, the output of each photosensor should be checked.

To check the output of a photosensor, first remove the bottom cover as described in para.4.3. Connect the lamp supply, and ensure that the lamp voltage, measured at the lamp, is $9.5V \pm 0.1V$.

Connect a 500 ohm load between the appropriate pins on the base of the reading head. (The circuit diagram is shown in figs 3 and 5).

The current supplied to the 500 ohm load by the cell must not be less than 350 microamps.

4.19 Motor Removal and Adjustments

Remove the top cover (4.1), side cover (4.2) capstan guard and machine table (4.7). Remove the 4 BA cheese-head screw adjacent to the 12-way plug and the centre screw at the base of the baffle plate. Slacken the remaining screw and the baffle plate can be swung clear of the motor and fan.

Disconnect the wiring from the terminal block mounted on the support bracket. Remove the four 2 BA screws holding the motor to the machine casting. Remove the motor from the machine.

Remove the fan, if fitting a replacement motor.

Replacing the Motor

Cut the motor leads to the same length as on the replaced motor. Fit the terminal block support bracket and slide the fan onto the rear of the motor shaft. Fit the motor into the machine. Set the centre line of the drive shaft directly over the centre line of the clutch rollers. Tighten down the motor securing screws, check that the capstan height is correct to the capstan height gauge No. 1(2/4)B157022. If the height is incorrect, insert shims between the motor plate and the machine casting, until the height is correct to the gauge.

NOTE: When adding shims, always shim both front, or both rear points by the same amount, to prevent strain on any of the parts involved.

Slacken the four screws securing the clutch slightly, and move the clutch assembly as far as possible towards the photocell assembly. Then place the Capstan and Clutch Alignment Gauge (1(2/4)B157021) on the ground faces of the base plate, in place of the top plate assembly. Locate the gauge by means of the two dowels projecting from the ground faces of the base plate and the two slip bushes, which should be locked in position in the gauge, and use feeler gauges to measure the gap between the gauge and the capstan. The gap may be 0.008 in. to 0.012 in., but should not vary by more than 0.0005 in. over the length of the capstan.

To achieve these conditions, slacken the four motor base securing screws slightly, and adjust the motor position to give the correct gap alongside the capstan. Sufficient clearance exists about the securing screws to allow this to be done. Tighten the screws when the motor is correctly set, and recheck setting.

Reconnect the motor leads, move the fan to its correct position and lock in place. Reposition the baffle plate, fit the machine table and the capstan guard.

Carry out clutch checks as in section 4.13.

4.20 Brake Pressure Spring Adjustment

Insert into the reader a loop of punched tape containing 500 characters. These characters must fill the tape length and the joint must be a perfect butt joined with a piece of Sellotape as described in section 3.6.

Run the loop for some minutes to bed down this joint. Adjust the pressure spring adjusting screw until the loop is passing through

at the correct speed, 20 loops in 10 seconds for TRM 1000/95 readers and 10 loops in 10 seconds for TRM 500/93 readers. As an alternative check observe the differentiated strobe pulses produced from the sprocket holes, on an oscilloscope using an appropriate time base. When the speed is adjusted to specification, tighten the dome head locknut.

4.21 Tape Guides Adjustment

The two front roller tape guides are adjustable to ensure that the tape is held in the correct location while passing through the machine.

Remove the capstan guard and the machine table (4.7) and insert the tape width gauge No. A50146. Slacken off the front roller clamps (clamping nuts at the lower end of the L. H. roller and a clamping screw on the offset arm of the R. H. roller).

Adjust the roller to the dimensions on the gauge, check the rollers at all positions of the tape width gauge. Tighten the clamping nuts and screw.

Replace the machine table and the capstan guard.

4.22 Microswitch Removal

Remove the top cover (4.1), side cover (4.2) and the capstan guard and machine table (4.7). The microswitches can now be removed after firstly removing the mounting screws and withdrawing the microswitches sufficiently to enable the terminal screws to be loosened and the leads removed. Replace in reverse order.

4.23 Pinch Roller Removal

Remove the top cover (4.1), side cover (4.2) and the capstan guard and machine table (4.7).

Remove the two 10 BA countersunk screws clamping the locking plate to the roller bracket and then lift off the locking plate. Gently withdraw the roller shaft taking care not to lose any of the spacers between the end rollers and the roller bracket ears. As the rollers are taken off caution must be exercised to ensure that the rollers remain in the same order and the same way round for re-assembling.

Before re-assembling clean the shaft and rollers and re-lubricate as in section 6.3.

Re-assemble in reverse order then check that the gap between any two rollers is 0.006 in. to 0.009 in. Check that the rollers spin freely.

NOTE: If a replacement pinch roller or clutch roller shaft is required a new shaft, complete with three new rollers, must be fitted. These are supplied as a set, Part No. A7462. For the correct use of this set see Appendix 1.

Chapter 5: READ STATION SETTING PROCEDURE, AMPLIFIERS

Setting Up Procedure

Tools and Materials

Avo Model 8

Tektronix Oscilloscope

D. C. Valve Voltmeter suitable for measuring 150 mV.

Accurately punched test tape, all holes punched.

5.1 Initial Tests

Remove the bottom cover plate as in section 4.3 and with the Avometer on Ohms range with the positive lead connected to earth, check the resistance of the three voltage lines.

+10 volts	200 to 300 ohms.
-10 volts	200 to 300 ohms.
-20 volts	4 to 5 Kohms.

Remove the top cover (4.1) and check that a 12V 48 watt lamp has been fitted.

Connect the 18-way plug (plug 2) on the rear of the reader and switch the reader ON. The clutch, brake and tape guide pins should now be checked and set in the approved manner, sections 4.13, 4.10 and 4.21 respectively.

See that the motor is running and that the lamp is on.

NOTE: The photovoltaic cells and their associated amplifiers are wired according to the resistor colour code, i.e. Channel 1 has brown wire on the amplifier input and output, Channel 4 (the sprocket hole) has yellow.

5.2 Cell Output

Insert the 18-way and 12-way plugs, switch on the reader and check that the voltages on the printed circuit board are as stated.

With the Avometer on the 50 microamps range check that all photocells (except the sprocket hole, PC 4 yellow) have an output greater than half FSD by placing the Avometer across the 330 ohms resistor (situated close to the potentiometer) in each channel.

Position some punched paper tape in the reader so that the sprocket hole is directly over the read head hole. In this condition check that the output from the sprocket hole photocell is greater than half FSD as above. If this one cell is low, remove the machine table as in section 4.7 to expose the top of the read head assembly and check that the read head has been positioned correctly with 9 to the front and 1 to the rear of the reader.

5.3 Bias and Threshold

Complete section 5.2, then insert the red miniature "Wanda" plug into the black socket and position some punched paper tape in the reader so that the sprocket hole is directly over the read head hole. Switch the Avometer to the 50 microamp range, connect the negative lead to earth on the printed circuit board and the positive lead to the solder post PC 4.

Adjust the red potentiometer for FSD on the avometer, then reduce the lamp voltage until the Avometer reads half FSD. Remove the Avometer leads and replace the red wanda plug into the red socket.

Connect the earth terminal on the valve voltmeter to earth on the printed circuit board, connect the positive lead to solder post PC 4. Connect the pink wire on the solder post marked 'BIAS' on the board (near voltage inputs) to the earth solder post. Observe the valve voltmeter

reading. Disconnect the pink wire from earth and connect it to K +10 volts, then to K -10 volts and then to K -20 volts. Note the valve voltmeter reading in each position, secure the pink wire in the position which gives the reading closest to 150 mV.

Disconnect the test lead from solder post PC 4 and connect it in turn to each of the solder posts PC 1 to PC 9. The valve voltmeter should in each case read between 90 mV and 210 mV. Disconnect the valve voltmeter and rotate all the black potentiometers fully anti-clockwise.

With the Avometer on 10 volts d.c. range connect the positive lead to the board earth and the negative lead to solder post 0-4. Rotate the sprocket hole potentiometer (channel 4 yellow) clockwise until the Avometer reads 9.5 volts.

Break the light beam with the hand and observe that the Avometer reading is now +2 volts.

Remove the hand from the light beam and observe that the Avometer again reads not less than 9.5 volts. If not, then slightly increase the clockwise rotation of the potentiometer and repeat the above paragraph.

Remove the tape from the reader and connect the Avometer negative lead to solder post 0-1. Rotate channel 1 (brown) potentiometer clockwise until the Avometer reads 9.5 volts. Break the light beam with the hand and observe that the Avometer falls to zero.

Remove the hand and the Avometer should again read not less than 9.5 volts. If not, then slightly adjust the potentiometer and repeat the above.

Connect the Avometer negative lead to solder posts 0-2, 0-3, 0-5, 0-6, 0-7, 0-8 and 0-9 in turn and at each step repeat the above test, using the potentiometer associated with the channel on test.

NOTE: Do NOT try to adjust channel 4 (yellow) again
without the punched paper tape in position.

5.4 Appendix TRM 500/93

Load a loop of tape in the reader which is punched with repetitive full house (letter shift on 5 channel tape). The tape must comply with international specification on pitch and paragraph (1) of the Teletype 110 Punch Quality Control Schedule P2.

Monitor the reader outputs, press the run out button and check that the sprocket hole output lies within the ratios

-10 volts	52%	+2 volts	48%
-10 volts	44%	+2 volts	56%

and the code hole outputs

-10 volts	60%	EARTH	40%
-10 volts	70%	EARTH	30%

Monitor the sprocket hole output on one trace and the code hole outputs in turn on the other. Code hole outputs should go negative between 100 and 220 microseconds before the sprocket hole output goes negative. There should be no cross talk between adjacent output channels.

By using the half light method the mark:space ratio for sprocket hole is 52 to 58 ON (mark)

48 to 42 OFF (space)

code hole is 67 to 76 ON (mark)

33 to 24 OFF (space)

The above is observed when using tape punched with a full house in every character position(see Figure 1). Do not alter the mark/space ratio when using tape.

Any errors in mark:space ratio could be due to the following:-

- (1) Incorrect setting of potentiometer during setting up.
- (2) Read head positioned wrongly relative to the fixed tape guides.
- (3) A difference in lamp voltage between the on-line and off-line testing, (note, the 803 has a C. V. transformer which can only be measured for voltage with a moving iron meter).

An 803 P. T. S. with both readers switched on has a lamp voltage of only 9 volts due to the drop in the cable, etc.

- (4) Poorly punched tape which can be:-

holes off punched laterally.

holes not punched at right angles to the guide edge.

holes not correctly spaced.

holes with furry edges.

5.5 Appendix TRM 1000/95

Load a loop of tape in the reader which is punched with repetitive full house (letter shift on 5 channel tape). The tape must comply with international specifications on pitch and paragraph (1) of the Teletype 110 Punch Quality Control Schedule P2. Remove base of reader plugged into channel 1.

Monitor the sprocket hole of the reader on pin A5/18 of the control console backwiring, taking care not to short the pin to earth. Preferably using a Tektronix scope and the internal positive trigger, adjust

the black potentiometer in section 'a' of the printed circuit board in the base of the reader, so that by depressing the run out button a waveform with ratio of:-

DARK 48 to 42
LIGHT 52 to 58 is obtained on the scope.

This is best checked by arranging the part of the waveform between any two sprocket holes going from light to dark to fill exactly ten graticule lines on the scope.

Again, using the Tektronix scope, monitor code hole 1 which is pin A3/C on the control console backwiring. Run 8 hole full house punched tape through the reader by depressing the run out switch and adjust the black potentiometer in section 'b' of the amplifier until a waveform of the following ratio is obtained:-

DARK 33 to 24
LIGHT 67 to 76

Repeat as above for the remaining 7 code holes, monitoring and adjusting potentiometers as listed below:-

Code hole	2	Monitor	A3/H	Adjust potentiometer	in section	c		
"	"	3	"	A3/K	"	"	"	d
"	"	5	"	A3/P	"	"	"	e
"	"	6	"	A3/Y	"	"	"	f
"	"	7	"	A3/AC	"	"	"	g
"	"	8	"	A3/AE	"	"	"	h
"	"	9	"	A3/30	"	"	"	j

Remove base of reader plugged into channel 2 then read as
for channel 1, but monitor pins:-

Sprocket hole	pin	A19/18	potentiometer in section a			
Code hole 1	"	A21/C	"	"	"	b
"	" 2	A21/H	"	"	"	c
"	" 3	A21/K	"	"	"	d
"	" 5	A21/P	"	"	"	e
"	" 6	A21/Y	"	"	"	f
"	" 7	A21/AC	"	"	"	g
"	" 8	A21/AE	"	"	"	h
"	" 9	A21/30	"	"	"	j

Do not forget to replace the reader bottom cover and feet.

Chapter 6: MAINTENANCE INSTRUCTIONS

6.1 Maintenance Interval

The period between checks will depend upon the degree of use of the tape reader but in general, it is recommended that the following procedure be carried out monthly or every 100 hours continuous running. No adjustments are necessary if performance is satisfactory.

CAUTION: The tape track must be kept clean and free from oil and grease deposits at all times.

Do not attempt any maintenance or adjustments on the reader without first reading the appropriate adjustments instructions thoroughly.

6.2 Recommended Maintenance

Check and reset if necessary:-

- (a) the clutch clearance - section 4.13
- (b) the clutch force - section 4.14
- (c) the brake force - section 4.10
- (d) the brake pressure spring setting - section 4.20
- (e) the optical system - section 4.5
- (f) the data and sprocket output waveforms. (See Figure 1)

Clean:-

- (a) the prism - with clean soft surgical cloth and water
- (b) the tape guides
- (c) the window
- (d) the capstan guard, machine table and tape track.

6.3 Lubrication

Pinch Rollers. Remove the rollers from their shaft as in section 4.23. Clean off all old oil, check for signs of wear then re-lubricate with three drops of B. P. CS65 oil inside each roller.

Clutch Roller Bracket Pivot. Remove the top and side covers as in sections 4.1 and 4.2. With the machine base upwards place a drop of S. A. E. 140 oil in the knife edge groove. Allow sufficient time for the oil to disperse before returning the machine to its base.

Tape Guide Rollers. Lubricate by placing a little S. A. E. 140 oil on the top of the roller pins and allow to disperse. **THOROUGHLY CLEAN THE TAPE TRACK.**

NOTE: On later models with fixed guide rollers, lubrication is no longer required.

Chapter 7: TOOLS LIST

Ref.No.	Description	Part No.
1	Tape Reader Test Tape	D4/22/A195
2	Tape Width Setting Gauge	A50146
3	Capstan and Clutch Alignment Gauge	1(2/4)B157021
4	Capstan Height Gauge	1(2/4)B157022
5	Brake & Clutch Force Test Tape Clamp	1(2/4)A120212
6	Correx Gauge 50-500 Grammes	7065
7	Correx Gauge 2-100 Grammes	-
8	Read Head Setting Gauge	T477
9	Salter 32 oz. Compression Spring Gauge	13797

Chapter 8: PARTS LIST

(see 'Exploded' Diagram for Reference Numbers)

Ref.No.	Description	Part No.
1	Screw 4 BA Ch.Hd.	S496E
2	Washer 4 BA	W384E
3	Lamp Contact	D4/22/A50
4	Lamp 12V 48W	D4/6/826
5	Contact Post	D4/22/A49
6	Screw 4 BA Ch.Hd.	S425E
7	Washer 4 BA	W384E
8	Retainer Plate	D4/22/A412
9	Screw 4 BA Ch.Hd.	S425E
10	Washer 4 BA	W68E
11	Lamp Bracket	D4/22/B278
12	Screw 6 BA Csk.Hd.	S653A
13	Prism	D4/22/A61
14	Screw 6 BA Ch.Hd.	S6082E
15	Washer 6 BA	W412E
16	Nut 6 BA	N153E
17	Screw 6 BA Inst.Hd.	S682J
18	Screw 6 BA Inst.Hd.	S682J
19	Guide Pin Screw	D4/22/A9
20	Guide Pin Roller	D4/22/A34
21	Washer	D4/22/A290
22	Capstan Guard	D4/22/B712
23	Window	D4/22/A200
24	Screw 6 BA Skt.Hd.	XN70479-04
25	Top Plate Assembly	D4/22/B261
26	Tape Guide	D4/22/A24
27	Arm Pivot	D4/22/A2

Ref.No.	Description	Part No.
28	Washer 4 BA	W35E
29	Washer 4 BA	W12E
30	Nut 4 BA	N13E
31	Guide Pin Lever Assembly	D4/22/A55
32	Spring Clip	D4/22/A60
33	Ball	D4/6/139
34	Selector Arm Guide	D4/22/A5
35	Screw 6 BA Ch.Hd.	S621E
36	Selector Arm	D4/22/A4
37	Pressel Bar	D4/22/A704
38	Screw 4 BA Grub	D4/5/205P
39	Guide Pin Mounting	D4/22/A8
40	Guide Pin Extension	D4/22/A11
40A	Guide Pin Screw	D4/22/A691
41	Guide Pin Screw	D4/22/A217
42	Screw 8 BA Ch.Hd.	S816E
42A	Washer 8 BA Shakeproof	XN87310-05
43	Return Spring	D4/22/A76
44	Spring Post	D4/22/A142
45	Roller Shaft	D4/22/A166
46	{ Washers	D4/22/A128
	{ Washers	D4/22/A161
	{ Washers	D4/22/A162
47	Needle Bearing	D4/22/A173
48	Roller Bracket	D4/22/A150
49	Locking Plate	D4/22/A27
50	Screw 10 BA Csk.Hd.	S1015E
51	Armature	D4/22/A13
52	Armature Shim	D4/22/A116
		D4/22/A680

Ref. No.	Description	Part No.
53	Screw 8 BA Grub	S826
54	Nut 8 BA	N2
55	Screw 8 BA Ch.Hd.	S891E
56	Washer 8 BA Shakeproof	W277
57	Screw 6 BA Csk.Hd.	XN70478-08
58	Screw 8 BA Csk.Hd.	S818E
59	Stop Block	D4/22/B293
60	Screw 8 BA Grub	D4/5/241
61	Screw 6 BA Ch.Hd.	XN70478-06
62	Clutch Roller Pivot	D4/22/A12
63	Clutch Spring	D4/22/A143
64	Adjusting Screw	D4/22/A32
65	Locknut 4 BA	N13E
66	Bolt	D4/22/A63
67	Lower Clamp	D4/22/A46
68	Lamination Assembly	D4/22/A78
69	Coil Assembly	D4/22/A108
70	Clutch Bracket	D4/22/B30
71	Shim, Clutch Bracket	D4/22/A251
72	Washer 2 BA	W385E
73	Nut 2 BA	N19E
74	Screw 4 BA Ch.Hd.	S4109E
75	Screw 6 BA Csk.Hd.	S653E
76	Tagboard	D4/22/A77
77	Insulator	D4/22/A57
78	Screw 4 BA Skt.Cap Hd.	D4/5/25
79	Setting Nut	D4/22/A129
80	Screw 6 BA Skt.Set.	XN70115-06
81	Armature Bracket	A7236

Ref.No.	Description	Part No.
82	Locating Pin	D4/22/A170
83	Pressure Spring	D4/22/A171
84	Armature Carrier	D4/22/A67
85	Damping Pad	D4/22/A73
86	Brake Armature	D4/22/A40
87	Screw 6 BA Csk.Hd.	XN70453-04
88	Brake Pad	D4/22/A41
89	Brake Pad Shim	D4/22/A93
90	Upper Clamp	D4/22/A45
91	Dowel	XN52234-05
92	Screw 6 BA Csk.Hd.	XN70317-08
93	Brake Bracket	D4/22/B31
94	Bolt	D4/22/A63
95	Lower Clamp	D4/22/A46
96	Coil Assembly	D4/22/A108
97	Lamination Assembly	D4/22/A78
98	Nut 2 BA	XN45800-02
99	Brake Bracket Shim	D4/22/A250
100	Screw 4 BA Ch.Hd.	S4109E
100A	Washer 4 BA Shakeproof	W275E
101	Screw 6 BA Csk.Hd.	XN70317-06
102	Tagboard	D4/22/A77
103	Insulator	D4/22/A57
104	Top Cover Assembly	D4/22/B88
105	Screw 6 BA Mush.Hd.	D4/5/195J
106	Mounting Bracket Assembly	D4/22/B81
107	{ Motor Assembly (TRM 1000/95)	D4/22/B117
	{ Motor Assembly (TRM 500/93)	D4/22/B165
108	Screw 3 BA Ch.Hd.	S233E

Ref.No.	Description	Part No.
109	Washer 2 BA	XN87321-01
109A	Shim	D4/22/A281
110	Toggle Switch	D4/6/258
111	Microswitch	D4/6/117
112	Screw 4 BA Csk.Hd.	S419E
113	Plug (Fixed) 12-way	D4/6/118
114	Plug (Fixed) 18-way	D4/6/119
115	Screw 4 BA Pan.Hd.	D4/5/252
116	Fan	D4/22/A71
117	Baffle Plate	D4/22/B29
118	Screw 4 BA Ch. Hd.	S496E
118A	Washer 4 BA	W400E
119	Base	D4/22/D44
120	Spring Post	D4/22/A33
121	Washer 6 BA	W412E
122	Nut 6 BA	N153E
123	Microswitch	D4/6/116
124	Switch Insulator	D4/22/A147
125	Screw 6 BA Ch.Hd.	XN70311-13
126	Capacitor (TRM 1000/95)	D4/6/1636
	Capacitor (TRM 500/93)	D4/6/173
127	Screw 4 BA Ch.Hd.	S425E
128	Washer 4 BA	W400E
129	Read Head Assembly	D4/22/B410
-	Photovoltaic Cell	D4/6/744
130	{ Capacitor Clip (TRM 1000/95)	D4/6/122
	{ Capacitor Clip (TRM 500/93)	D4/22/A185
131	Screw 6 BA Ch.Hd.	S6081E
131A	Washer	W412E

Ref.No.	Description	Part No.
132	Side Cover Assembly	D4/22/B419
133	Screw 6 BA Mush. Hd.	D4/5/195J
134	Circuit Board Assembly	D4/22/C430
135	Base Cover	D4/22/B407
136	Threaded Spacer	D4/22/A404
137	Tapped Spacer	D4/22/A405
138	Foot	XN28601-01
139	Screw 4 BA Ch.Hd.	XN70310-09
140	Screw 4 BA Grub	S498E
141	Dowel Pin	D4/22/A294

APPENDIX 1: USE OF CLUTCH ROLLER/SPINDLE SET

If a replacement clutch pinch roller or clutch roller shaft is required, a new shaft, complete with three new rollers must be fitted. These are supplied as a set, Part No. A7462. The rollers are mounted on the shaft in the correct order and orientation when packed for transit, and this arrangement must be maintained when the parts are fitted in a clutch assembly.

When the set is required for use, the rollers should be removed from the shaft for lubrication (see para.6.3) and then replace in their original positions as the shaft is inserted into the clutch roller bracket. New spacers should also be fitted as required, so that the gap between any two rollers is 0.004 in. to 0.006 in. When the correct spacers have been fitted, re-assemble the remainder of the reader.

An unpunched loop of tape should then be inserted in the reader and run at the maximum speed of the reader for a period of four hours. At the end of this time dismantle the clutch pinch roller shaft and rollers and carry out the procedures given in para.6.3. Note that the gap between any two rollers should now be in the range quoted in para.4.23.

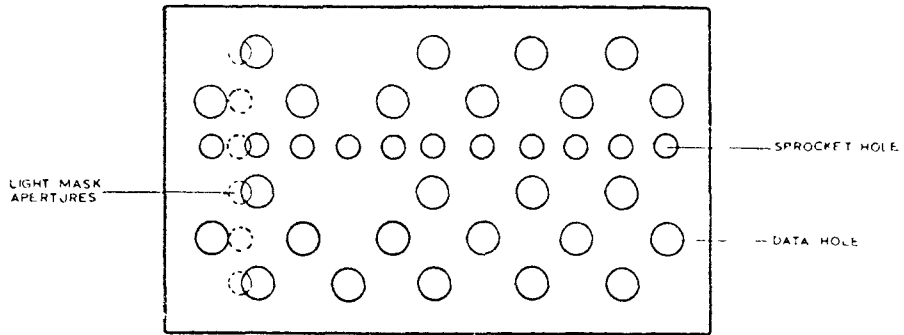

SECTION OF TYPICAL PUNCHED TAPE

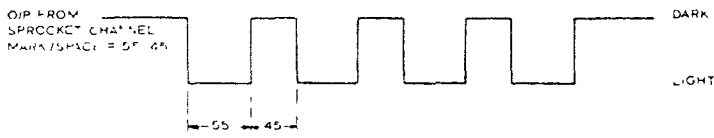
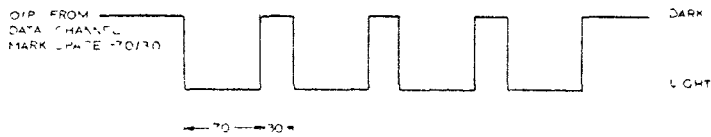

TYPICAL OUTPUT WAVEFORMS FROM FULLY PUNCHED TAPE

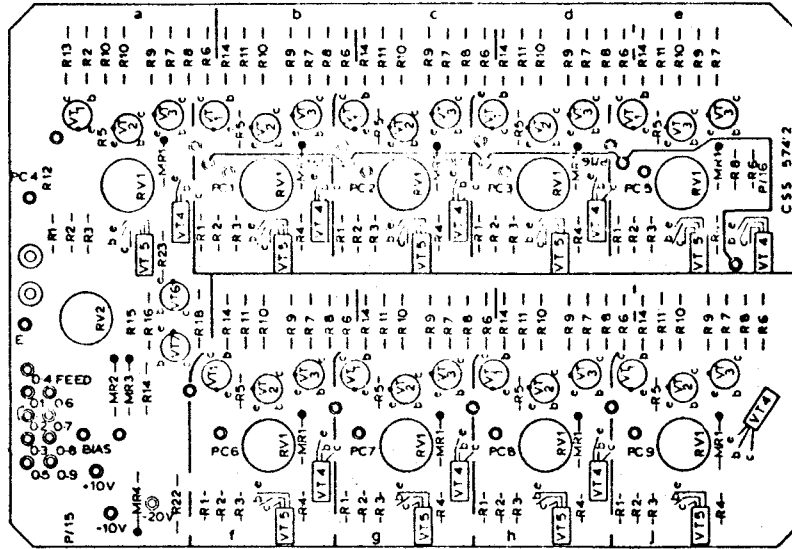

TRM 500 - 93
COMPONENT TABLE

	Value	Tol. %		Cat. No.
R				
1 & 2	47K	5	W	D4/6/731
3	330	5	W	D4/6/732
4, 17 & 18	10K	5	W	D4/6/741
5	180K	5	W	D4/6/952
6	220K	5	W	D4/6/732
7	1K	5	W	D4/6/735
8	22K	5	W	D4/6/736
9 & 14	1.5K	5	W	D4/6/737
10 & 22	11K	5	W	D4/6/738
11	100K	5	W	D4/6/730
12	62	5	W	D4/6/739
13	220	5	W	D4/6/771
15	2.7K	5	W	D4/6/740
16	160	5	W	D4/6/770
19	1.2K	5	W	D4/6/742
20 & 23	27K	5	W	D4/6/733
21	3.3K	5	W	D4/6/743
RV				
1	100K			D4/6/745
2	1K			D4/6/729
MR	Type			
1 & 4	OA202			D4/6/752
2	OA2243			D4/6/754
3	OA47			D4/6/753
VT				
1 & 2	2N1305			D4/6/749
3				D4/6/746
4 & 5	OC. 202			D4/6/481
6	2N337			D4/6/750
7	2N1302			D4/6/751
PLUG (BLACK)				D4/6/778
SOCKET (BLACK)				D4/6/779
SOCKET (RED)				D4/6/780

Figure 2 (ISSUE 1)

CIRCUIT BOARD-COMPONENT LAYOUT (TRM 500)

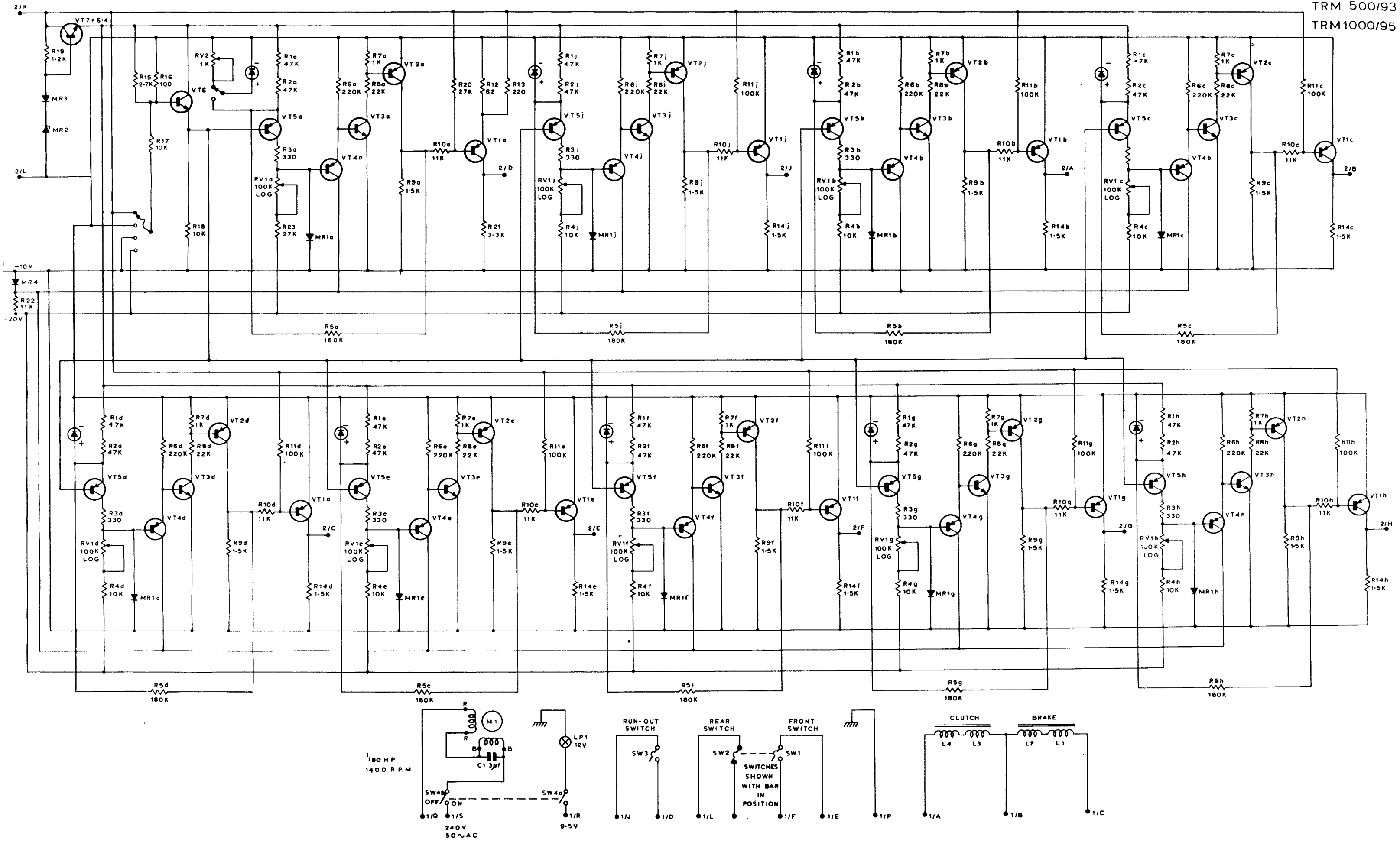

RM 500/93 CIRCUIT DIAGRAM

Figure 3 (ISSUE 2)

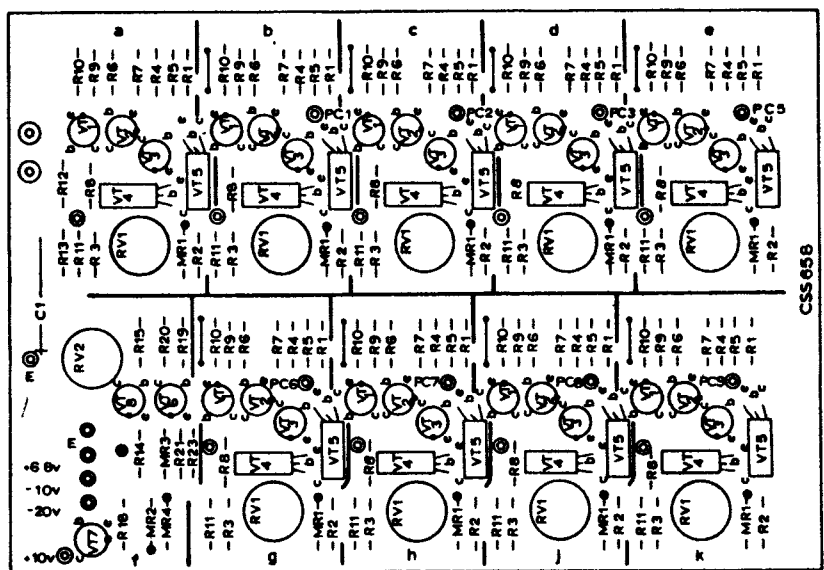

TRM 1000 - 95 COMPONENT TABLE			
R	Value	Tol. ± %	Cat No.
1a	100K	5TE	D4/6/730
1b, c, d, e, g, h, j, k.	150K	5TE	D4/6/1127
2a, b, c, d, e, g, h, j, k.	330	5TE	D4/6/732
3a	27K	5TE	D4/6/733
3b, c, d, e, g, h, j, k. & 21 & 22f.	10K	5TE	D4/6/741
4a, b, c, d, e, g, h, j, k. & 5a	220K	5TE	D4/6/731
5b, c, d, e, g, h, j, k.	270K	5TE	D4/6/1129
6a, b, c, d, e, g, h, j, k.	1K	5TE	D4/6/735
7a, b, c, d, e, g, h, j, k.	22K	5TE	D4/6/736
8a & 19f.	2.7K	5TE	D4/6/740
8b, c, d, e, g, h, j, k: 11a, b, c, d, e, g, h, j, k.	4.7K	5TE	D4/6/1128
9a, b, c, d, e, g, h, j, k.	3.3K	5TE	D4/6/743
10a	2.2K	5TE	D4/6/1131
10b, c, d, e, g, h, j, k.	5.1K	5TE	D4/6/1130

TRM 1000 - 95 COMPONENT TABLE			
	Value	Tol. ± %	Cat. No.
12a	270	5TE	D4/6/1132
13a & 20	100	5TE	D4/6/770
14f	470	5TE	D4/6/1133
15f	680	5TE	D4/6/1134
18f	820	5TE	D4/6/1135
RV			
1a, b, c, d, e, g, h, j, k.	100K		D4/6/1140
2f	1K		D4/6/729
C			
1	4µf	+50 -10	16V D4/6/1136
MP			
1a, b, c, d, e, g, h, j, k. & 3f	OA202		D4/6/752
2f	OAZ244		D4/6/1139
4f	OAZ247		D4/6/1137
VT			
1a, b, c, d, e, g, h, j, k.	ASY26		D4/6/1138
2a, b, c, d, e, g, h, j, k.	2N1305		D4/6/749
8f			
3a, b, c, d, e, g, h, j, k. & 7f	2N1306		D4/6/746
4a, b, c, d, e, g, h, j, k.	OC202		D4/6/481
5a, b, c, d, e, g, h, j, k. & 6f	2N337		D4/6/750
Socket	(Black)		D4/6/779
Socket	(Red)		D4/6/780

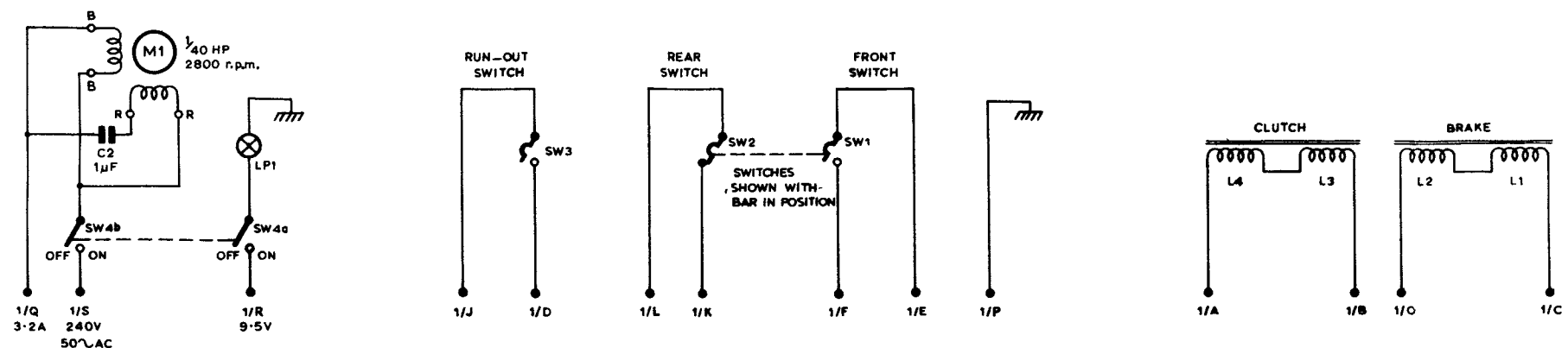
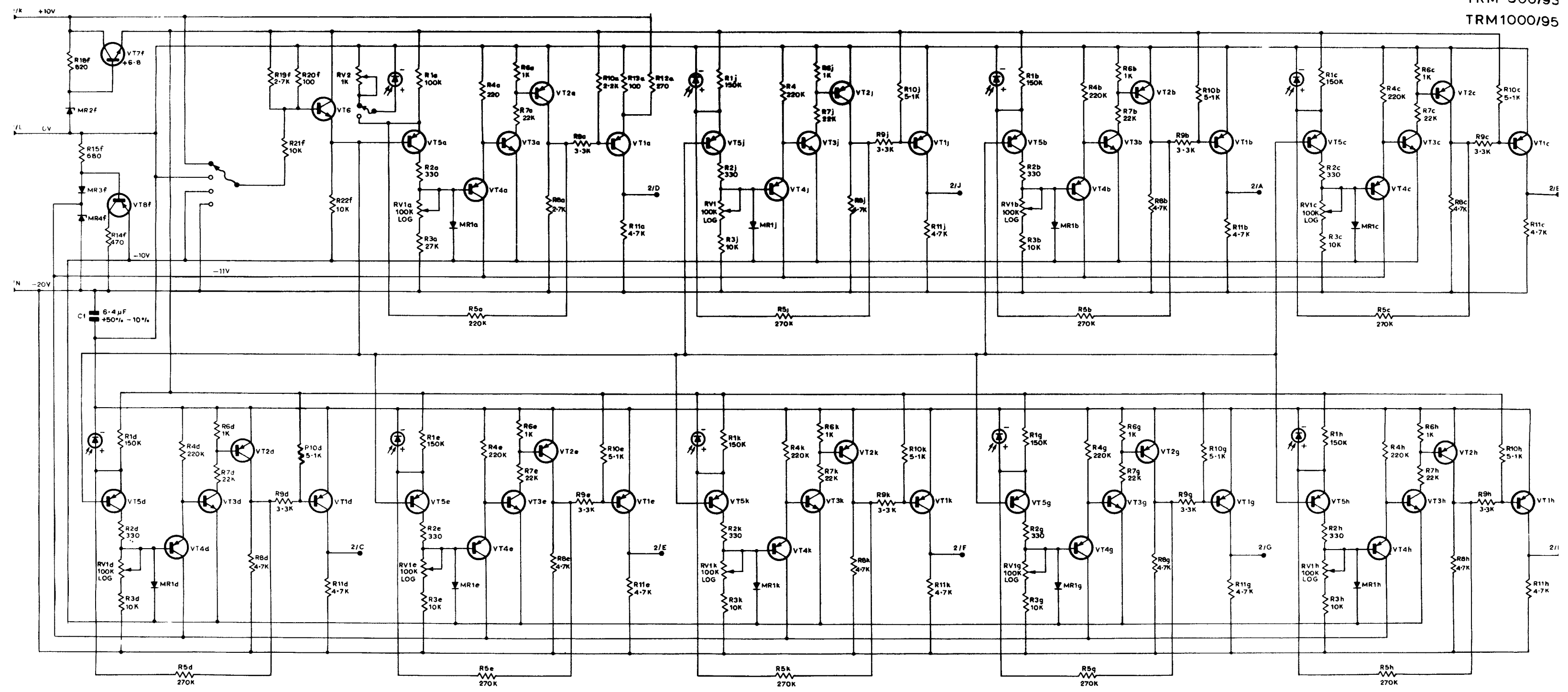

TRM1000/95 CIRCUIT DIAGRAM

Figure 5 (ISSUE 2)

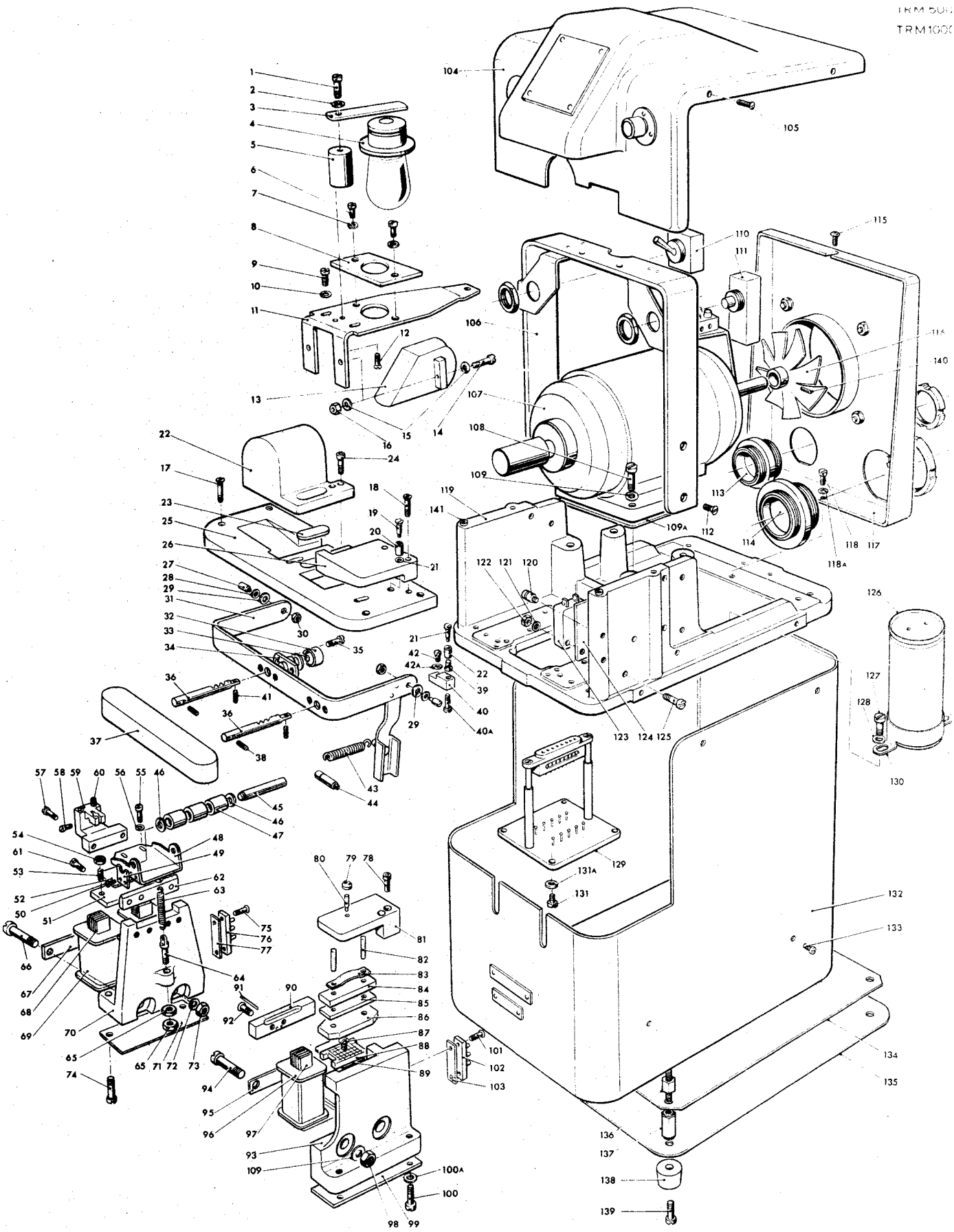

ILLUSTRATED PARTS LIST

Figure 1