

As you are now the owner of this document which should have come to you for free, please consider making a donation of £1 or more for the upkeep of the (Radar) website which holds this document. I give my time for free, but it costs me money to bring this document to you. You can donate here <https://blunham.com/Radar>

Do not upload this copyright pdf document to any other website. Breaching copyright may result in a criminal conviction and large payment for Royalties.

This pdf document was generated by me Colin Hinson from a Crown copyright document held at R.A.F. Henlow Signals Museum. It is presented here (for free) under the Open Government Licence (O.G.L.) and this pdf version of the document is my copyright (along with the Crown Copyright) in much the same way as a photograph would be.

The document should have been downloaded from my website <https://blunham.com/Radar>, or any mirror site named on that site. If you downloaded it from elsewhere, please let me know (particularly if you were charged for it). You can contact me via my Genuki email page: <https://www.genuki.org.uk/big/eng/YKS/various?recipient=colin>

You may not copy the file for onward transmission of the data nor attempt to make monetary gain by the use of these files. If you want someone else to have a copy of the file, point them at the website (<https://blunham.com/Radar>). Please do not point them at the file itself as it may move or the site may be updated.

It should be noted that most of the pages are identifiable as having been processed by me.

I put a lot of time into producing these files which is why you are met with this page when you open the file.

In order to generate this file, I need to scan the pages, split the double pages and remove any edge marks such as punch holes, clean up the pages, set the relevant pages to be all the same size and alignment. I then run Omnipage (OCR) to generate the searchable text and then generate the pdf file.

Hopefully after all that, I end up with a presentable file. If you find missing pages, pages in the wrong order, anything else wrong with the file or simply want to make a comment, please drop me a line (see above).

If you find the file(s) of use to you, you might like to make a donation for the upkeep of the website – see <https://blunham.com/Radar> for a link to do so.

Colin Hinson

In the village of Blunham, Bedfordshire, UK.

AIR PUBLICATION

117E-0106-1

BR 1771 (22)

**SIGNAL GENERATORS
CT.433 and CT433A**

**GENERAL AND TECHNICAL
INFORMATION**

BY COMMAND OF THE DEFENCE COUNCIL

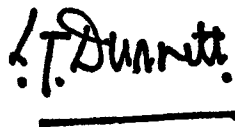
A handwritten signature in black ink, appearing to read 'J. Dunnett', is written above a solid horizontal line.

Ministry of Defence

FOR USE IN THE
ROYAL NAVY
ROYAL AIR FORCE

(Prepared by the Ministry of Technology)
Issued December 1967

B.R. 1771(22)

C.R.E.T.E.

Handbook for

SIGNAL GENERATORS

CT 433 NSN 6625-99-943-4059

AND

CT433A NSN 6625-99-195-4684

(REVISED 1968)

BY COMMAND OF THE DEFENCE COUNCIL

L. T. Dunnett

MARCH 1968

MINISTRY OF DEFENCE
DIRECTOR GENERAL WEAPONS (NAVAL)
(N/W 6 1 1 5/67)

FOREWORD

THE SEVEN PART DOCUMENTATION SYSTEM

1. B.R.1771(22) has been revised to include information on the Signal Generator CT433A, to bring up-to-date the information on Signal Generator CT433, and to present the book in the form of the Ministry of Defence Naval Weapon Specification No. 1 (N.W.S.1). A layout of this documentation system is shown overleaf.
2. The normal handbook consists of Parts 1 to 5. Parts 6 and 7 are issued as separate documents with restricted distribution, if needed.
3. For B.R.1771(22), only Parts 2B, 2C, 5A, 5C, 5E and 5F are applicable.

<u>GENERAL TITLE</u>	<u>PART NO.</u>	<u>SUB-TITLE</u>	<u>RESPONSIBILITY</u>
Overall Documentation Coverage	1	CATALOGUE OF INFORMATION	Design Authority
General & User Information	2	A COMMAND INFORMATION	Design Authority
		B GENERAL DESCRIPTION	" "
		C OPERATING INSTRUCTIONS	User School
		D USER INFORMATION	" "
System or Equipment Information	3	A EQUIPMENT TECH. DESCRIPTION	Design Authority
		B SWITCHING ON/OFF, SETTING-UP, PERFORMANCE TESTS	" "
		C FAULT DIAGNOSIS	" "
		D EQUIPMENT REPAIR	" "
Drawings for Part 3	4	A SMALL DRAWINGS (DEMY FOLIO)	" "
		B LARGE DRAWINGS	" "
Assembly & Unit Information (with drawings)	5	A TECHNICAL DESCRIPTION	" "
		B SWITCHING ON/OFF SETTING-UP	" "
		C MAINTENANCE	Design Authority & Class Authority
		D REPAIR	Design Authority
		E PARTS LIST	" "
Installation & Proving Information	6	A INSTALLATION	Design Authority
		B PREPARATION FOR ACCEPTANCE	" "
		C ACCEPTANCE SCHEDULES	" "
Repair Information	7	MAJOR REPAIR	Design Authority

THE SEVEN-PART DOCUMENTATION SYSTEM

SIGNAL GENERATOR CT433, NSN 6625-99-943-4059
(formerly A.P.104290)

AND

SIGNAL GENERATOR CT433A, NSN 6625-99-195-4684

SUMMARY OF DATA

OTHER SERVICE OR COMMERCIAL DESIGNATIONS

Advance Components Type J1A.

PURPOSE

Audio frequency source for general testing of A.M. receivers, A.F. amplifiers and frequency calibration of time-bases of oscilloscopes.

DESCRIPTION

Consists of an RC bridge oscillator feeding through a buffer valve into an output stage.

The output voltage is controlled by a calibrated potentiometer.

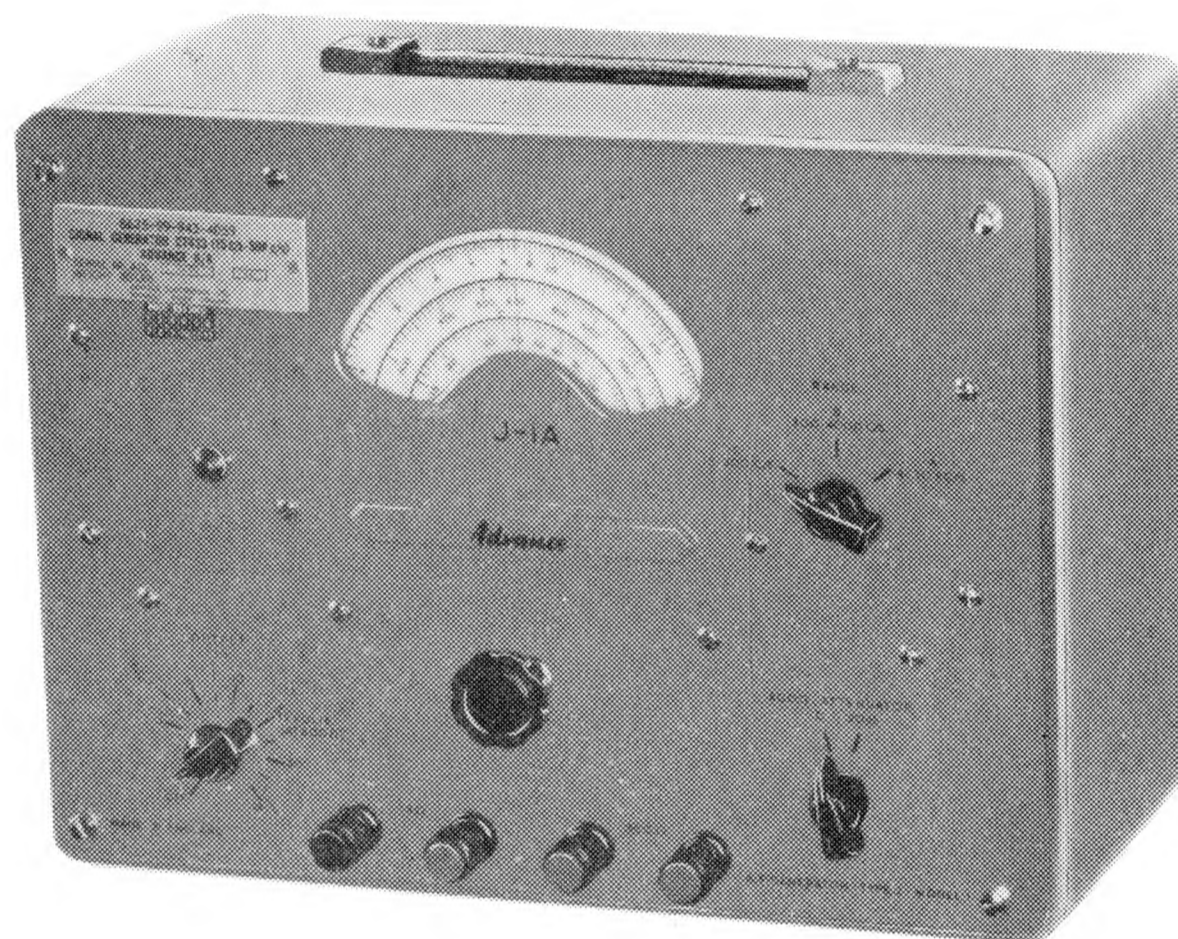

PERFORMANCE AND ACCURACY

- Frequency Range : three ranges - 15 Hz to 300 Hz
300 Hz to 4 kHz
4 kHz to 50 kHz
Accuracy $\pm 2\% \pm 1$ Hz
- Output : 0.1 mW to 1 W (0.25 to 25 V) continuously variable into 600 ohms
Accuracy ± 2 dB
Max. output into 5 ohms, greater than $\frac{1}{2}$ W, continuously variable
- Output Impedance : Approx. 600 ohms over the whole range
Where close accuracy is required, the 20 dB attenuator should be used - this gives 10 mW (2.5 V) max. output.
- Distortion : Total harmonic and hum content compared to fundamental -
Better than 34 dB down (2%) at full output) above 100 Hz
Better than 40 dB down (1%) at 0.1 W)

PHYSICAL DATA

Height 10 $\frac{1}{4}$ in Width 13 $\frac{1}{2}$ in Depth 8 $\frac{1}{4}$ in Weight 20 lb

POWER REQUIREMENTS AND CONSUMPTION

40 W { 105 to 125 and 210 to 250 V
40 to 100 Hz

SUPERSEDED INSTRUMENT

A.P.W7252 Oscillator G205

PRODUCTION SPECIFICATION

A.S.W.E. 17136R

DESIGN AUTHORITY

D.G.W.(R)

HANDBOOKS

B.R.1771(22) Handbook for Signal Generators CT433 NSN 6625-99-943-4059 and CT433A NSN 6625-99-195-4684.

C . R . E . T . E . H A N D B O O K F O R S I G N A L G E N E R A T O R SC T 4 3 3 N S N 6 6 2 5 - 9 9 - 9 4 3 - 4 0 5 9C T 4 3 3 A N S N 6 6 2 5 - 9 9 - 1 9 5 - 4 6 8 4CONTENTS LIST

SUMMARY OF DATA

PART 2B	INTRODUCTION
PART 2C	OPERATING INSTRUCTIONS
PART 5A	TECHNICAL DESCRIPTION
PART 5C	MAINTENANCE AND FAULT FINDING
PART 5E	COMPONENTS LISTS
PART 5F	ILLUSTRATIONS



SIGNAL GENERATOR CT433
6625-99-943-4059

FIG.1

P A R T 2 BI N T R O D U C T I O N

1. The Signal Generator CT433 and the later version CT433A are general purpose audio frequency signal generators. They cover the range 15 Hz to 50 kHz in three bands to an accuracy of about $\pm 2\%$. The output from either instrument, normally connected to a 600 ohms impedance, is continuously variable between 0.1 mW and 1 W (0.25 to 25 V).
2. The CT433 uses international octal valves that are now obsolescent whilst the CT433A, from serial number 1457, uses modern miniature valves. There is a consequent change of valve-holders, retainers and circuit (see Figure 3), but the electrical specification is unchanged.
3. In naval service there are a few CT433 Mod. 1 versions. These and the CT433A are identical.

P A R T 2 C

O P E R A T I N G I N S T R U C T I O N S

C O N T E N T S L I S T

	<u>Paragraph</u>
POWER SUPPLY TAP CHANGING	1-2
FREQUENCY CONTROL	3
OUTPUT CONTROL	4
OPERATION WITH LOADS GREATER THAN 600 OHMS	5-6
OPERATION WITH LOADS LESS THAN 600 OHMS	7-8
THE 5 OHMS OUTPUT	9-10
MEASUREMENT OF OUTPUT VOLTAGE USING AVOMETER	11

P A R T 2 CO P E R A T I N G I N S T R U C T I O N SPOWER SUPPLY TAP CHANGING

1. The Signal Generator CT433 or CT433A (Advance J1/A) is normally despatched with the mains transformer tapping set to operate at 210-250 V, and the tapping must be changed for 105-125 V operation. To change the tapping to 105-125 V, remove the disc on the underside of the case (two screws), uncovering the tags of the mains transformer. Tag 2 is connected to tag 3 for 210-250 V input. For 105-125 V, unsolder the connection between tag 2 and tag 3. Connect tag 1 to tag 2 and tag 3 to tag 4. Do not disturb the mains leads already connected to tags 1 and 4. Replace the cover disc. (If the tag numbering is obliterated, tag 4 is identified as that nearest to the left-hand side and tag 1 as that nearest to the centre of the main chassis.) It is suggested that a tie-on label be attached to the instrument warning that it is set to 105-125 V.

CAUTION If the instrument is plugged into a 210-250 V supply point when set to 105-125 V it may be damaged as there is NO INTERNAL FUSE.

WARNING The instrument is provided with a 3-core cable, so that the case can be earthed via the mains cable. It is essential that the GREEN EARTH LEAD of the 3-core cable is connected to earth in the mains plug, otherwise the instrument may become live and be capable of giving a lethal electric shock.

2. The ON/OFF switch is incorporated in the output control and only single pole switching is provided.

FREQUENCY CONTROL

3. A signal of any frequency between 15 Hz and 50 kHz is set using the range switch in conjunction with the calibrated dial. Continuous adjustment is available by means of the slow motion control situated centrally below the dial.

OUTPUT CONTROL

4. Output into a 600 ohms load is taken from the two red terminals '600 ohms'; neither is connected to earth, but either may be earthed by linking to the black 'earth' terminal. Output into a 5 ohms load is taken between the black terminal marked 'E' (which is an earthing terminal connected to case and 'mains' earth via the 3-core mains lead) and the red terminal next to it. Variation of the output level is obtained by use of the output control. An additional control of output at 600 ohms is provided by the 20 dB attenuator (+ 10 when matched) by use of which an accurate output impedance is obtained. The output control of the instrument is calibrated in volts and decibels with reference to 1 mW into 600 ohms. The output circuit of the instrument operates as if it were a zero impedance generator in series with a 600 ohms internal resistance. If the load is also 600 ohms then the voltage of the generator is equally divided between the internal and external resistances and the voltage appearing across the external load resistor is one half of the ACTUAL generator voltage. The instrument OUTPUT scale is calibrated so that the scale voltage is that across a 600 ohms load connected externally. The calibration will be

incorrect at any other load resistance. For example, when the instrument is used with an external load of say 100 000 ohms (e.g. an audio amplifier grid resistor) and the 20 dB attenuator is not used, a voltage approximately twice that indicated is applied to the load, and there is some increase in distortion at high output levels. When the 20 dB attenuator is in circuit and the output is loaded with 600 ohms then the output voltage is one tenth of that indicated. When the load is of high impedance the output voltage after the 20 dB attenuator is one fifth of that indicated.

OPERATION WITH LOADS GREATER THAN 600 OHMS

5. If a load resistance greater than 600 ohms is to be used, then either a resistor of suitable value should be added in parallel with the load and the voltage read direct from the calibration, or, alternatively, the voltage may be calculated.

Voltage across load of R ohms is given by:-

$$\text{Actual Voltage} = \text{Indicated voltage} \times 2 \times \frac{R}{R + 600}$$

6. The factor of TWO arises from the open circuit generator e.m.f. being twice that indicated by the OUTPUT control. The same formula applies when the 20 dB attenuator is in circuit except that the further factor of + 10 is included.

OPERATION WITH LOADS LESS THAN 600 OHMS

7. In the simple case, an additional resistance should be added in series with the load resistance to make up the total value to 600 ohms. The actual voltage across a load r ohms with a series resistor R will be:-

$$= \text{Indicated Voltage} \times \frac{r}{(R + r)}$$

$$= \text{Indicated Voltage} \times \frac{r}{600} \quad \text{since } (R + r) = 600 \text{ ohms.}$$

Provided the ratio of the load resistor and series resistor is accurately known, then this calculation gives the 'load' voltage to an accuracy which is mainly determined by the instrument itself. In general, however, many cases will arise where it is necessary to know the actual voltage across a load resistor of a nominal value. Large errors can occur due to the tolerance of the various resistors and it is suggested that the most accurate and easily available method is to add suitable resistors of about the correct value in series (e.g. + 20% carbon resistors) and MEASURE the applied voltage using 6625-99-972-0247 Multimeter CT471.

8. It is possible to set up a low voltage by the following method. Set up a voltage ten times that required and then switch in the 20 dB pad. It is necessary, however, to ensure that the equipment under test is not overloaded by this procedure, (i.e. temporarily switch off the power supply of the equipment under test but do not disconnect the load).

THE 5 OHMS OUTPUT

9. This is a low impedance output primarily designed to apply up to $\frac{1}{2}$ W to loudspeakers (direct to the speech coil), to test them for rattles, buzzes

and other major defects, by listening to the sound of the speaker as the audio frequency is varied. For speech, a coverage of about 200-3000 Hz is usually required and for music, 100-8000 Hz on low-quality equipment, rising to 30-20 000 Hz on high fidelity equipment.

10. The output voltage is best measured using either a Multimeter CT471 or a calibrated oscilloscope. One side of the 5 ohms winding is earthed.

MEASUREMENT OF OUTPUT VOLTAGE USING AVOMETER

11. Any Avometer may be used from about 25 Hz to a top frequency of 5-10 kHz (see actual meter data) to measure the output of the instrument. It must be remembered however that the current requirements of the lower a.c. ranges of some meters are fairly high and in some cases the meter resistance itself will form an appreciable part of the instrument load resistance.

PART 5ATECHNICAL DESCRIPTIONCONTENTS LIST

	<u>Paragraph</u>
GENERAL	1
PANEL FEATURES	2
THE OSCILLATOR CIRCUIT	3-5
THE OUTPUT STAGE	6-7
THE OUTPUT CONTROL	8
THE POWER SUPPLY	9

PART 5A

TECHNICAL DESCRIPTION

GENERAL

1. The instrument consists of a Wien bridge oscillator with level stabilisation by a thermistor, feeding an output stage via a buffer amplifier.

PANEL FEATURES

2. Referring to Figure 1. The front panel has the following controls and terminals mounted on it:-

(a) Output

The output control is a switched potentiometer (S3 RV15). The switch (S3) is the mains ON/OFF switch with OFF position marked. The potentiometer (RV15) controls the output voltage and is calibrated in volts and decibels with respect to 1 mW in 600 ohms. The correct voltage is only obtained across the 600 ohm terminals when they are shunted by a 600 ohms load.

(b) Frequency Controls

Range - A 3-position range switch (S1) at the right-hand side of the main dial.

Range A 4-50 kHz (fully clockwise)

Range B 300-4000 Hz

Range C 15-300 Hz.

The Main Dial (The Fine Frequency Control) is situated behind a transparent insert in the panel and the cursor is a single vertical line engraved on the transparent insert. The dial is rotated by a friction-reduction drive and knob (controlling C5 and C6) situated immediately below the maker's trade mark.

(c) 600 ohm Attenuator

A 2-position rotary switch (S2) places either a 20 dB pad in series with the 600 ohms output terminals or switches the pad out of circuit altogether.

(d) Terminals

There are four output terminals. Reading from left to right:

No. 1 Black - This is connected to the instrument case, and also to the 'mains earth' via the mains input cable.

No. 2 Red with the symbol '5Ω' between it and No. 1 - This is the live terminal with a nominal 5 ohms output impedance.

No. 3 and No. 4 Red with the symbol '600Ω' between them.

These terminals are isolated from earth and provide the nominal 600 ohms output. Either side may be earthed by linking to the black earth terminal No. 1.

CAUTION A d.c. voltage should not be applied to the 5 ohms output terminal No. 2. The d.c. voltage applied between the 600 ohms output terminals and earth should not exceed 100 V.

THE OSCILLATOR CIRCUIT

3. A modified Wein bridge oscillator circuit is used. The main ratio arms are the cathode load of V1a (R9 and R10) together with the total anode load of V1a, i.e. the thermistors TH1 and TH2, part of RV14, also R8 in parallel. The thermistor TH1 has a 'cold' resistance at 20 °C of about 100 000 ohms and operates 'hot' at several thousand ohms resistance. TH2 plus the output control are shunted across the relatively low 'hot' resistance of TH1. Neglecting R7 + R32 for the moment, it will be seen that the frequency selective arms of the bridge consist of C5 plus one of R4, R5 or R6 (depending on the frequency range in use) in the series arm and C6 plus one of R1, R2 or R3 in the parallel arm. C1 to C4 inclusive are trimming capacitors to set up the frequency calibration of the main dial.*

4. For the higher frequencies (ranges A and B), C7 is effectively a short circuit, but for range C (15-300 Hz) it forms an additional phase shift network with R7 + R32 (R34 is selected during manufacture to adjust the low frequency calibration). When the impedance of C7 is low compared with the resistance of R7 + R32 the phase shift is negligible and R7 + R32 have little effect on the frequency calibration. This additional phase shift is used to extend the low frequency coverage of the oscillator. It will be noted that the coverage of ranges A and B is about 12.5:1 and 13.3:1 respectively whilst range C is 20:1.

5. The valve V1b is used as part of the maintaining amplifier system and both halves of V1 are working as Class A amplifiers.

THE OUTPUT STAGE

6. The valves V2 and V3 operate as a buffer amplifier and an output stage respectively. Two output transformers are used, one for the low frequency ranges 'B' and 'C' and one for the high frequency range 'A'. Voltage negative feedback, for gain stabilisation and harmonics reduction, is applied between the anode of V3 and the cathode of V2 by R20, C13 and R19. Current negative feedback, is applied to the output stage by R23, C15 and RV24. RV24 is a preset rheostat that is adjusted in production to set the output impedance of the amplifier to a nominal 600 ohms. The two output transformers have different winding losses. The resistor R31 is added to compensate for the lower losses of the high frequency transformer and thus retain the 600 ohms output impedance on all ranges. C15 is used as a frequency selective negative feedback control to maintain a substantially flat frequency response of the amplifier over the whole range. The components C12, R17 and R16 are used to reduce the hum output of the instrument. The ripple on the h.t. line appears across T1 (or T2) and valve V3. Since the a.c. impedance of the beam tetrode is high, only a small amount of this ripple appears across the output terminals. This is partially cancelled out by dividing by about ten - the ratio of R17 and R16 - amplifying and inverting by V2, and applying to the grid of V3 to reduce the output ripple.

* In CT433A, C4 is a fixed capacitor.

7. The thermistor TH2 is used to compensate for the change in oscillator level with temperature, so that the output voltage calibration is substantially correct at different temperatures.

THE OUTPUT CONTROL

8. The potentiometer RV15 is used to control the input to the amplifier. It is calibrated in output voltage - assuming the 600 ohm terminals are loaded by a 600 ohms load. C10 is an additional capacitor to give a little 'top lift' to compensate for the loss of the gain of the output stage at higher frequencies thus preserving the 'flat' output of the instrument.

THE POWER SUPPLY

9. The power supply consists of a conventional full wave rectifier with resistance-capacitance smoothing. C18 and C19 are used to prevent r.f. or other signals getting on to the h.t. line and causing undesirable modulation of the output of the oscillator.

PART 5CMAINTENANCE AND FAULT FINDINGCONTENTS LIST

	<u>Paragraph</u>
GENERAL	1
MECHANICAL FEATURES	2
RAPID PERFORMANCE TEST	3
REMOVAL OF INSTRUMENT FROM ITS CASE	4
LOCATION OF MAJOR COMPONENTS	5
LOCALISING FAULTS	6
COMPONENT FAILURES - EFFECT ON CALIBRATION OF CERTAIN COMPONENTS	7
LIMITED CALIBRATION PROCEDURE	8

TABLES

	<u>Table</u>
Fault Finding Guide	5C.1
Valve Complements	5C.2
Signal Generator CT433	5C.3
Signal Generator CT433A	5C.4

P A R T 5 CM A I N T E N A N C E A N D F A U L T F I N D I N GGENERAL

1. The instrument should not require any routine adjustments. The following data is given for emergency use, but the instrument should be recalibrated by Defect List procedure in the event of failure and subsequent shipboard repair.

MECHANICAL FEATURES

2. The undermentioned conventions have been adopted in the description that follows:-
 - (1) The outer metal case is referred to as the CASE.
 - (2) The FRONT PANEL of the instrument is the panel on which the main controls are mounted. The front of the panel is seen when looking at the outside of the instrument.
 - (3) The welded sheet metal framework behind the front panel is the MAIN CHASSIS and the SCREEN is the metal sheet, over the ganged capacitor, which is held on by the seven self-tapping screws.
 - (4) The terms top, bottom, front, back, left-hand side and right-hand side are used on the assumption that the instrument is in a normal horizontal position and viewed from the front.

RAPID PERFORMANCE TEST

3. The following paragraphs provide a quick method of determining whether the instrument is working normally. These tests can be performed without removing the instrument from its case.

NOTE If faults are indicated by the following tests, proceed to paragraphs 4 to 7 as necessary.

- (1) Apparatus Required
 - (a) Instrument under test.
 - (b) Pair of telephones or a loudspeaker.
 - (c) 6625-99-972-0247 Multimeter CT471.
 - (d) 600 ohms \pm 1% 1.5 W resistance.

This resistance should be built up from Grade I Resistors, and the final value adjusted to 600 ohms \pm 1% as measured by 6625-99-972-4702 Bridge Universal CT492.

- (e) 6625-99-105-7049 Multimeter Set CT498A or
6625-99-943-1524 Multimeter Model 8SX.
- (f) A.P.6496 Bridge Megger.
- (g) 6625-99-971-8518 Counter, Electrical Frequency CT487 or
6625-99-971-8519 Counter, Electrical Frequency CT488.

(2) Preliminary Continuity and Insulation Checks

When it is suspected that the instrument is faulty, it is necessary to carry out preliminary checks of continuity and insulation, because the instrument is not protected by an internal fuse.

- (a) Disconnect the mains lead from the mains supply and turn the OUTPUT control to 0 V (i.e. mains switch ON). Using a multimeter, measure the continuity resistance of the primary of the mains transformer from the terminals of the mains plug. This resistance should be about 30 ohms if the instrument is connected for 210-250 V working, and about 7 ohms if the instrument is connected for 105-125 V working.
- (b) Using a multimeter, check the action of the ON/OFF switch on the OUTPUT control, by measuring the continuity resistance at the mains plug.
- (c) Using A.P.6496 Bridge Megger, measure the insulation resistance to earth of the primary of the mains transformer at the mains plug. This resistance should be greater than 50 megohms.
- (d) Using a multimeter, measure the resistance between the 5 ohms output terminals No. 1 and No. 2. This resistance should be about 2.5 ohms on Range B and Range C, and about 0.5 ohm on Range A.
- (e) Using a multimeter, measure the resistance between the 600 ohms output terminals No. 3 and No. 4 with the 600 ohms ATTENUATOR switch to 0 dB. This resistance should be about 85 ohms on Range B and Range C, and about 130 ohms on Range A.
- (f) Using a multimeter, measure the resistance between the 600 ohms output terminals No. 3 and No. 4 with the 600 ohms ATTENUATOR switched to 20 dB. This resistance should be about 600 ohms on all ranges.
- (g) Using A.P.6496 Bridge Megger, measure the insulation resistance to earth of the 600 ohms output terminals. The resistance should be greater than 50 megohms.

(3) Preparation for Test

- (a) Measure the a.c. mains supply voltage and ensure that the supply socket is supported by a 2 A fuse, as the instrument is not protected by internal fuses.
- (b) Check that the mains transformer tapping of the instrument is correct, by removing the disc on the underside of the case (two screws) and inspecting the tags of the mains transformer.

For 210-250 V working, tag 2 is connected to tag 3.
For 105-125 V working, tag 1 is connected to tag 2 and tag 3 is connected to tag 4.

Do not disturb the mains lead already connected to tags 1 and 4. Replace the cover disc.

- (c) Connect the mains plug to the a.c. mains supply socket. Turn the OUTPUT control to 0 V, thus switching on the instrument, and allow two minutes for warm-up. Check that the pilot lamp is alight. If it is not refer to Table 5C.1, Symptom 1.

(4) Details of Test

- (a) Check the presence of an output. Use a pair of telephones or a loudspeaker connected to the 600 ohms or 5 ohms terminals as appropriate. Adjust the OUTPUT control to give a convenient intensity of sound and check at 4 kHz on Ranges A and B, and at 300 Hz on Ranges B and C. If the test is unsatisfactory Table 5C.1, Symptoms 2 to 6 may indicate a possible fault.
- (b) Check the level of output. Connect a Multimeter CT471 (40 V a.c. range) across the 600 ohms output terminals (600 ohms attenuator to 0). Turn the OUTPUT control to 15 V and swing the main dial throughout its travel on each frequency range in turn. A reading of approximately 30 V should be indicated on the multimeter at all frequencies. A variation of approximately ± 2 V is to be expected. If the test is unsatisfactory Table 5C.1, Symptom 7 may indicate a possible fault.
- (c) Check the output impedance. Connect a Multimeter CT471 (40 V a.c. range) across the 600 ohms output terminals (600 ohms attenuator to 0). Turn the OUTPUT control to give 40 V on the multimeter at 1000 Hz on Range B. Connect the made-up 600 ohms $\pm 1\%$ resistor across the 600 ohms output terminals. The meter should now read 20 V ± 1 V. Repeat the operation at 10 kHz on Range A and at 200 Hz on Range C. If the test is unsatisfactory Table 5C.1, Symptom 8 may indicate a possible fault.
- (d) Check the 600 ohms attenuator. Connect a Multimeter CT471 (40 V a.c. range) and the 600 ohms $\pm 1\%$ resistor across the 600 ohms output terminals (600 ohms attenuator to 0). Turn the OUTPUT control to give 20 V on the multimeter at 100 Hz on Range B. Switch the 600 ohms ATTENUATOR to 20 dB. Measure the output voltage using the 4 V a.c. range. This should be 2 V ± 0.1 V. If it is not refer to Table 5C.1, Symptom 9.
- (e) Frequency calibration check. Connect a Counter Electrical Frequency CT487 or CT488 across the 600 ohms output terminals (600 ohms attenuator at 20 dB), and turn the OUTPUT control to approximately 10 V. Check the frequency at the top, middle and bottom of all three ranges, to an accuracy within $\pm 2\%$ ± 1 Hz. If the test is unsatisfactory the instrument should be recalibrated, normally by a dockyard but a limited calibration procedure is given in Paragraph 9.

TABLE 5C.1 - FAULT-FINDING GUIDE

Symptom	Possible Cause
(1) Pilot lamp does not light on completion of preparation for test.	<p>(a) No mains supply. Check fuses of supply socket.</p> <p>(b) Defective pilot lamp or pilot lamp circuit. Proceed with Paragraph 4 then check that the bulb filament is not open circuit. Check voltage at bulb holder (5.5 V a.c. approximately to earth with multimeter when bulb alight).</p> <p><u>NOTE</u> The yellow lead to the bulb holder consists of resistance wire.</p>
(2) No note obtained on any range.	<p>This is a major fault, which may be due to lack of h.t. on any valve circuit, to a defective interstage coupling component or valve, or to a defective switch S1. Proceed with Paragraph 4 and voltage tests in Paragraph 6.</p>
(3) Note obtained on range A and B, but not on C.	<p>(a) Incorrect operation of RANGE switch S1. Proceed with Paragraph 4 and then check circuit of Switch S1.</p> <p>(b) Defective range C circuit R6, R1 and C3. Check circuit.</p>
(4) Note obtained on range A and C, but not on B.	<p>(a) Incorrect operation of RANGE switch S1. Proceed with Paragraph 4 and then check circuit of switch S1.</p> <p>(b) Defective range B circuit R5, R2 and C2. Check circuit.</p>
(5) Note obtained on range B and C, but not on A.	<p>(a) Incorrect operation of RANGE switch S1. Proceed with Paragraph 4 and then check circuit of switch S1.</p> <p>(b) Defective range A circuit R4, R3 and C1. Check circuit.</p> <p>(c) Defective output transformer T2. Check transformer T2.</p>
(6) Note obtained on range A, but not on B or C.	<p>(a) Defective output transformer T1. Proceed with Paragraph 4 and then check transformer T1.</p> <p>(b) Incorrect operation of RANGE switch S1. Check switch S1.</p>
(7) Incorrect output voltages obtained when instrument is not terminated.	<p>(a) Incorrect h.t. voltage. Proceed with Paragraph 4 and then check h.t. voltage.</p> <p>(b) Defective oscillator circuit. Check oscillator output volts on V2 grid (7.5 V a.c. approximately using Multimeter CT471 on 12 V a.c. range).</p> <p>(c) Defective output circuit. Check V2 and V3 voltages as in Paragraph 6.</p>

Symptom	Possible Cause
(8) Correct output voltages obtained when instrument is not terminated, but incorrect voltages obtained when instrument is terminated.	(a) Defective output circuit. Proceed with Paragraph 4 and then check V2 and V3 voltages as in Paragraph 6. Check V2 and V3 circuits and output transformers. (b) Maladjustment of output circuit. See Paragraph 8.
(9) Incorrect change of output voltage when 600 ohms ATTENUATOR is switched to 20 dB.	Defective 600 ohms ATTENUATOR. Proceed with Paragraph 4 and then check the attenuator switch and resistors.

REMOVAL OF INSTRUMENT FROM ITS CASE

- 4.(1) Disconnect the mains lead from the a.c. supply socket, and any leads that may be connected to the output terminals.
- (2) Remove the two coin-slotted screws from the back on the instrument case and lay the instrument on its back.
- (3) Unscrew the four round-head screws in each corner of the front panel of the instrument a little at a time. The front panel will be lifted gradually from the case.
- (4) If access is required to the RANGE switch S1, or to the resistors R1 to R7, or to the capacitors C1 to C7, unscrew the seven self-tapping screws that retain the internal screening cover.

LOCATION OF MAJOR COMPONENTS

5.(1) Valves

The valves are mounted at the rear of the main chassis. Viewed from the front panel, and from right to left, the valve order is:-

TABLE 5C.2 - VALVE COMPLEMENTS

	CT433	CT433A
V1 Double Triode	6SN7GT (CV1988)	E88CC (CV2492)
V2 Triode	6J5GT (CV1934)	EC90, 6C4 (CV4058)
V3 Tetrode	6V6GT (CV511)	EL84 (CV2975)
V4 Full Wave Rectifier	6X5GT (CV574)	6X4 (CV4005)

(2) Transformers

The three transformers are mounted beneath the main chassis.

- (a) Mains transformer T3 is mounted between the valve holder of V4 and the OUTPUT control.
- (b) Output transformer (Low) T1 is the larger of the two transformers mounted behind the 600 ohms ATTENUATOR control.
- (c) Output transformer (High) T2 is the smaller of the two transformers mounted behind the 600 ohms ATTENUATOR control.

(3) Thermistors

The thermistors TH1 and TH2 are mounted in rubber grommets on the rear of output transformer T1. TH1 is the thermistor nearer the front panel. If the thermistors have to be removed, they must be carefully marked so that they are not inadvertently interchanged when they are reinserted in the circuit. If in any doubt, measure their resistance using a multimeter. TH1 has the higher resistance, approximately 100 kohms.

(4) Preset Potentiometers

Two preset potentiometers are mounted at the rear of the main chassis.

- (a) RV14 is mounted between V1 and V2.
- (b) RV24 is mounted between V3 and V4.

(5) Components under the Screening Cover

- (a) Resistors R1 to R6 inclusive are connected across the contacts of the range switch.
 - (b) Capacitors C1, C2 and C3 are special wire trimmers in the CT433 and ceramic trimmers in the CT433A. They are connected in parallel with R3, R2 and R1 respectively across the contacts of the RANGE switch.
 - (c) Capacitor C4 is a concentric trimmer in CT433 and a fixed capacitor in CT433A, connected to the two main ganged capacitors C5 and C6.
 - (d) Capacitor C7 is a large 0.1 μ F capacitor.
 - (e) Resistors R7 and R32 are mounted across the contacts of the RANGE switch.
 - (f) RANGE switch S1.
- (6) All other components can be located by simple circuit tracing.

LOCALISING FAULTS

WARNING The majority of the following tests have to be carried out with the instrument withdrawn from its case, and with the power on. In this condition the following voltages are exposed:

	<u>CT433</u>	<u>CT433A</u>
Maximum a.c. voltage (across anodes of V4)	550 V	600 V
Maximum d.c. voltage (cathode of V4 to earth)	300 V	335 V

- 6.(1) Connect the a.c. mains plug to the a.c. power supply socket, protected by 2 A fuses. Set the RANGE switch to B and adjust the main dial to 1 kHz. Set the 600 ohms ATTENUATOR to 20 dB and connect the 600 ohms \pm 1% resistor (made up) across the 600 ohms output terminals. Turn the OUTPUT control to 25 V. Wait two minutes for the instrument to warm up.
- (2) Check visually that the filaments of the valves V1 to V4 are alight. Inspect the chassis for signs of mechanical damage.
- (3) Proceed with the following voltage tests, as necessary, using a Multimeter CT471 and Multimeter Set CT498A, or Multimeter Model 8SX. The negative lead of the measuring instrument must be connected to chassis earth unless otherwise stated. Table 5C.3 shows a list of typical figures obtained with a correctly functioning Signal Generator CT433, on a mains supply of 240 V at 50 Hz.
- (4) If any great variation from the typical figures is obtained in any of the above tests, check the associated valve on 6625-99-943-2419 Test Set, Electronic Valve, CT160 and check the wiring and components associated with the test point. Renew any defective components or valves.

TABLE 5C.3 - SIGNAL GENERATOR CT433

Test Point	Multimeter	Range Setting	Typical Voltage
(a) Heater Voltages - Measure across heater pins for all valves. Pins 2 and 7 for valves V2, V3 and V4. Pins 7 and 8 for valve V1	CT471	12 V a.c.	6-6.4 V a.c.
	8SX	10 V a.c.	
	CT498A	10 V a.c.	
(b) Transformer h.t. output measured on valve V4 anodes. Pin 3 and earth, pin 5 and earth. Both voltages the same.	CT471	400 V a.c.	275 V a.c.
	8SX	1000 V a.c.	270 V a.c.
	CT498A	300 V a.c.	275 V a.c.
(c) V4 cathode, pin 8.	CT471	400 V d.c.	300 V d.c.
	8SX	500 V d.c.	
	CT498A	300 V d.c.	

Test Point	Multimeter	Range Setting	Typical Voltage	
(d) H.T. line measured for convenience at transformer T1, the tag with a red and black lead connected.	CT471	300 V d.c.	275 V d.c.	
	8SX	500 V d.c.		
	CT498A	300 V d.c.		
(e) H.T. at capacitor C20 measured for convenience at junction of R8 and R12 on tag board near V1.	CT471	400 V d.c.	250 V d.c.	
	8SX	250 V d.c.		
	CT498A	300 V d.c.		
(f) V1 anode a, pin 2. It is more convenient to measure on tag board of T1, end tag above RV14. V1 anode b, pin 5	CT471	400 V d.c.	135 V d.c.	
	8SX	250 V d.c.		
	CT498A	300 V d.c.		
	CT471	400 V d.c.	155 V d.c.	
	8SX	250 V d.c.		
	CT498A	300 V d.c.		
(g) V2 anode, pin 3 V2 grid, pin 5 V2 cathode, pin 8	CT471	400 V d.c.	145 V d.c.	
	8SX	250 V d.c.		
	CT498A	300 V d.c.		
	CT471	12 V a.c.	8 V a.c.	
	CT471	12 V d.c.	6.4 V d.c.	
		8SX		10 V d.c.
		CT498A		10 V d.c.
	(h) V3 anode, pin 3 V3 grid, pin 5 V3 cathode, pin 8 Measured across resistor R23 330 ohms	CT471	400 V d.c.	250 V d.c.
		8SX	500 V d.c.	
CT498A		300 V d.c.		
CT471		40 V a.c.	26 V a.c.	
CT471		40 V d.c.	13 V d.c.	
		8SX		25 V d.c.
		CT498A		30 V d.c.

TABLE 5C.4 - SIGNAL GENERATOR CT433A

Test Point	Multimeter	Range Setting	Typical Voltage
(a) Heater Voltages - Measure across heater pins for all valves. Pins 4 and 5 for valves V1 and V3. Pins 3 and 4 for valves V2 and V4.	CT471	12 V a.c.	6-6.4 V a.c.
	8SX	10 V a.c.	
	CT498A	10 V a.c.	
(b) Transformer h.t. output measured on valve V4 anodes. Pin 1 and earth, pin 6 and earth. Both voltages the same.	CT471	400 V a.c.	300 V a.c.
	8SX	1000 V a.c.	290 V a.c.
	CT498A	300 V a.c.	300 V a.c.
(c) V4 cathode, pin 7	CT471	400 V d.c.	330 V d.c.
	8SX	500 V d.c.	
	CT498A	1000 V d.c.	
(d) H.T. line measured for convenience at transformer T1, the tag with a red and black lead connected.	CT471	400 V d.c.	310 V d.c.
	8SX	500 V d.c.	310 V d.c.
	CT498A	1000 V d.c.	300 V d.c.
(e) H.T. at capacitor C20 measured for convenience at junction of R8 and R12 on tag board near V1.	CT471	400 V d.c.	280 V d.c.
	8SX	500 V d.c.	
	CT498A	300 V d.c.	
(f) V1 anode a, pin 1. It is more convenient to measure on tag board of T1, end tag above RV14.	CT471	400 V d.c.	135 V d.c.
	8SX	250 V d.c.	
	CT498A	300 V d.c.	
V1 anode b, pin 6. It is more convenient to measure on small tag board near V1, at the junction of C9 and R12.	CT471	400 V d.c.	165 V d.c.
	8SX	250 V d.c.	
	CT498A	300 V d.c.	

Test Point	Multimeter	Range Setting	Typical Voltage
(g) V2 anode, pin 1	CT471	400 V d.c.	140 V d.c.
	8SX	250 V d.c.	
	CT498A	300 V d.c.	
V2 grid, pin 6	CT471	12 V a.c.	7 V a.c.
V2 cathode, pin 7	CT471	12 V d.c.	6.5 V d.c.
	8SX	10 V d.c.	
	CT498A	10 V d.c.	
(h) V3 anode, pin 7	CT471	400 V d.c.	300 V d.c.
	8SX	500 V d.c.	
	CT498A	300 V d.c.	
V3 grid, pin 2	CT471	40 V a.c.	20 V a.c.
V3 cathode, pin 3. Measured across R23 220 ohms resistor.	CT471	12 V d.c.	9 V d.c.
	8SX	10 V d.c.	
	CT498A	10 V d.c.	

COMPONENT FAILURES - EFFECT ON CALIBRATION OF CERTAIN COMPONENTS

7. The renewal of some of the components will affect the calibration of the instrument. If any of the components listed below have to be renewed, the instrument is usable, but it should be recalibrated by Defect List action at the earliest opportunity.

(1) Components which affect frequency accuracy:

Resistors R1 to R7 inclusive, and R32
Capacitors C1 to C7 inclusive.

(2) Components which affect the output voltage calibration:

Thermistors TH1 and TH2
Variable resistors RV14 and RV15
Resistors R16, R17, R19 and R20, and R34 when fitted
Transformers T1 and T2.

(3) Components which affect the output impedance:

Resistors R19, R20, R31 and Variable resistor RV24
Capacitor C13
Transformers T1 and T2.

NOTE (a) Valve Renewal

Valves V2 and V4 can be renewed without difficulty, and will have little effect on the calibration accuracy of the instrument. If valve V3 is changed, the output impedance may alter. This can be readily adjusted by the method detailed in Paragraph 8(4). If V1 is changed it is necessary to check the current through TH1 as detailed in Paragraph 8(3).

(b) Output Transformer Replacement

It is essential that the connections to the renewed output transformer are made exactly as in the original wiring, and that the ends of winding should not be transposed.

LIMITED CALIBRATION PROCEDURE

8. The following limited calibration procedure is given to allow ships' staffs to obtain the best possible performance from the instrument subsequent to the repair of any defect. It is not a substitute for full recalibration procedure which can only be carried out by dockyards (see Paragraph 7 above).

(1) Apparatus Required

- (a) Instrument under test.
- (b) 6625-99-972-0247 Multimeter CT471.
- (c) 600 ohms \pm 1% 1.5 W Resistance.

This resistance should be built up from Grade 1 resistors and the final value adjusted to 600 ohms \pm 1% as measured by 6625-99-972-4702 Bridge Universal CT492.

- (d) 6625-99-971-8518 Counter, Electrical Frequency CT487, or
6625-99-971-8519 Counter, Electrical Frequency CT488.

(2) Voltage Calibration

- (a) Set the Main dial to 1000 Hz, the RANGE switch to B, and the 600 ohms ATTENUATOR to 0 dB. Connect Multimeter CT471 (40 V a.c. range) and the made-up 600 ohms resistance across the 600 ohms output terminals.
- (b) Switch on the instrument and turn the OUTPUT control on the front panel to give an indication on the multimeter. Then turn the OUTPUT control counter-clockwise to check that, for zero volts on the scale, there is no indication on the multimeter reducing range setting as necessary. If this is not so, undo the OUTPUT control knob locking screw and set the pointer of the control knob to 0 on the scale with no indication on the multimeter and relock the control knob.
- (c) Reset the Multimeter CT471 to the 40 V a.c. range, turn the OUTPUT control to 25 on the voltage scale and adjust the frequency to 20 kHz.
- (d) Check that the reading on the multimeter is 26 V. If it is not adjust RV14 until the reading is 26 V.

(3) Thermistor TH1 Current Check

The current through TH1 should be between 1.4 mA and 2.0 mA. If the current is below 1.3 mA corrective action is required.

NOTE There are three variations of this circuit in service:

- (1) A CT433 with serial number below 682 has no R34 fitted - so current will have to be measured directly by unsoldering the thermistor from the earthing tag and connecting Multimeter CT471 (4 mA a.c. range) in series with the thermistor lead and earth.
- (2) A CT433 above serial number 682 has R34 10 ohms fitted - so the voltage drop, across the resistor can be measured by connecting CT471 (40 mV a.c. range) across R34, and should be 14 mV to 20 mV. Below 13 mV corrective action is required.
- (3) A CT433A has R34 100 ohms fitted - so the voltage drop across the resistor can be measured by connecting CT471 (400 mV a.c. range) across R34 and should be 140 mV to 200 mV. Below 130 mV corrective action is required.

- (a) Measure the current through Thermistor TH1 by method (1), (2) or (3) above as appropriate, with the frequency adjusted to 20 kHz.
- (b) If the current is less than 1.3 mA change V1.
- (c) If the current is still less than 1.3 mA change TH1.

(4) Output Impedance Adjustment

- (a) Set the Main dial to 20 kHz and the 600 ohms ATTENUATOR to 0 dB. Connect a Multimeter CT471 (40 V a.c. range) across the 600 ohms output terminals.
- (b) Switch on the instrument and turn the OUTPUT control to give a reading of 40 V on the multimeter. Connect the 600 ohms $\pm 1\%$ resistance across the 600 ohms terminals and check that the multimeter reading falls to 20 V. If it does not adjust RV24 to obtain the multimeter reading of 20 V. Repeat this procedure until the output reading with the 600 ohms load is exactly half the reading with no load. The 600 ohms output impedance will now be correct.

(5) Frequency Calibration

This paragraph gives a few hints to correct calibration errors. As it only mentions adjustments which can easily be made it is not a substitute for the full calibration procedure.

- (a) Connect a Counter, Electrical Frequency CT487, or CT488, across the 600 ohms output terminals (600 ohms attenuator to 20 dB). Switch on the instrument and turn the OUTPUT control to approximately 10 V on the scale.

Check the frequencies at the top, middle and bottom of all three ranges to an accuracy within $\pm 2\% \pm 1$ Hz.

- (b) Adjustment should only be attempted if the instrument is only slightly out of calibration.

NOTE The calibration of Range A affects the calibration of both Ranges B and C, and if any adjustment is made to any range recheck all ranges.

- (c) Range C - If calibration is out at top end of the range (i.e. 300 Hz) adjust C3.
- (d) Range B - If calibration is out at top end of the range (i.e. 4 kHz) adjust C2.
- (e) Range A - If calibration is out at top end of the range (i.e. 50 kHz) adjust C1.
- (f) Only in CT433 is it possible to adjust C4 if C1, C2 or C3 has insufficient range.

NOTE To reach C1, C2 and C3 it is necessary to remove the screening cover and after adjustment it is essential to recheck calibration after replacing cover.

- (6) Reassemble the instrument as follows:-
- (a) Lay the case on its back and replace the instrument in its case. Ensure that the rubber grommet on the mains supply cable engages between the edges of the case and of the front panel.
- (b) Engage the threads of the four round-head screws in each corner of the front panel, and screw up evenly a little at a time.
- (c) Replace the two coin-slotted screws into the back of the instrument case.
- (7) Repeat the rapid performance test detailed in Paragraph 3(4) to ensure satisfactory operation.

6625-99-943-4059 SIGNAL GENERATOR CT433COMPONENTS LIST

Before ordering replaceable parts reference should be made to B.R.1923 "Substitution Guide for Electronic Components. For differences in CT433A see last page.

Cot. Ref.	NSN or other Ref. No.	Description	Value	Tol. ± %	Rating
	5910-99-	<u>CAPACITORS</u>	<u>µF</u>		<u>Volts</u>
C1	197-0535	Trico 004a/10BMD 20	4-20 p		
C2	197-0535	Trico 004a/10BMD 20	4-20 p		
C3	197-0535	Trico 004a/10BMD 20	4-20 p		
C4	016-7006	Variable, Air Dielectric	3-30 p		
C5	Non pattern	Ganged Variable	14-546 p		
C6	Non pattern	Ganged Variable	14-546 p		
C7	011-7818	Fixed, Paper Dielectric	0.1	20	350
C8	014-5504	Electrolytic	8	-20 +50	450
C9	011-7818	Fixed, Paper Dielectric	0.1	20	350
C10	012-7281	Ceramic	10	± 0.5 p	750
C11					
C12	011-7818	Fixed, Paper Dielectric	0.1	20	350
C13	011-7819	Fixed, Paper Dielectric	0.25	20	350
C14	011-7818	Fixed, Paper Dielectric, Metallised	0.1	20	350
C15	011-5828	Fixed, Paper Dielectric, Metallised	0.02	20	150
C16	972-9064	Electrolytic	16 + 16	-20 +50	350
C17	972-9064	Electrolytic	16 + 16	-20 +50	350
C18*	012-4288	Fixed, Mica Dielectric	4700 p	10	750
C19*	012-4288	Fixed, Mica Dielectric	4700 p	10	750
C20	972-9064	Electrolytic	16 + 16	-20 +50	350
C21	972-9064	Electrolytic	16 + 16	-20 +50	350
	5905-99-	<u>RESISTORS</u>	<u>Ohms</u>		<u>Watts</u>
R1	911-5775	Fixed, Composition, Grade 1, Non-Insulated	13 M	1	½
R2	021-6654	Fixed, Composition, Grade 1, Non-Insulated	1 M	1	½
R3	911-5776	Fixed, Composition, Grade 1, Non-Insulated	70 k	1	½
R4	911-5776	Fixed, Composition, Grade 1, Non-Insulated	70 k	1	½
R5	021-6654	Fixed, Composition, Grade 1, Non-Insulated	1 M	1	½
R6	911-5775	Fixed, Composition, Grade 1, Non-Insulated	13 M	1	½
R7	022-3056	Fixed, Composition, Grade 2, Insulated	150 k	5	½
R8	022-2171	Fixed, Composition, Grade 2, Insulated	22 k	5	½
R9	022-1199	Fixed, Composition, Grade 2, Insulated	510	5	½
R10	021-5700	Fixed, Composition, Grade 1, Non-Insulated	1.8 k	5	½
R11	022-3161	Fixed, Composition, Grade 2, Insulated	1 M	5	½
R12	022-2171	Fixed, Composition, Grade 2, Insulated	22 k	5	½
R13	022-2010	Fixed, Composition, Grade 2, Insulated	1 k	5	½
RV14	027-2005	Variable, Wirewound	5 k	5	1
RV15	972-8936	Variable, with Switch S3	25 k		
R16	022-2211	Fixed, Composition, Grade 2, Insulated	47 k	5	½
R17	022-3137	Fixed, Composition, Grade 2, Insulated	620 k	5	½
R18	022-2001	Fixed, Composition, Grade 2, Insulated	56 k	5	½
R19	022-2064	Fixed, Composition, Grade 2, Insulated	3.3 k	5	½
R20	021-6400	Fixed, Composition, Grade 1, Non-Insulated	62 k	5	½
R21	022-2045	Fixed, Composition, Grade 2, Insulated	2.2 k	5	½
R22	022-3161	Fixed, Composition, Grade 2, Insulated	1 M	5	½
R23	022-1171	Fixed, Composition, Grade 2, Insulated	330	5	½
RV24	027-1605	Variable, Wirewound	1 k	5	1
R25	021-5613	Fixed, Composition, Grade 1, Non-Insulated	750	2	1

* In original production 0.005 uF Capacitors were used. If C18 or C19 becomes faulty replace both Capacitors with 4700 pF, 5910-99-012-4288.

Cct. Ref.	NSN or other Ref. No.	Description	Value	Tol. ± %	Rating
	5905-99-	<u>RESISTORS (Contd.)</u>	<u>Ohms</u>		<u>Watts</u>
R26	911-5777	Fixed, Composition, Grade 1, Non-Insulated	2.97 k	1	½
R27	911-5778	Fixed, Composition, Grade 1, Non-Insulated	733	1	½
R28	011-7893	Fixed, Wirewound, Vitreous	510	5	4½
R29	022-1024	Fixed, Composition, Grade 2, Insulated	22	5	½
R30	022-1024	Fixed, Composition, Grade 2, Insulated	22	5	½
R31	022-1106	Fixed, Composition, Grade 2, Insulated	100	5	½
R32 †		Fixed, Composition, Grade 2, Insulated	0-50 k	5	½
R33					
R34	012-0211	Fixed, Composition, Grade 2, Insulated	10	5	½
		<u>VALVES, ELECTRONIC</u>			
V1	5960-99-000-1988	CV1988			
V2	5960-99-000-1934	CV1934			
V3	5960-99-000-0511	CV511			
V4	5960-99-000-0574	CV574			
		<u>MISCELLANEOUS</u>			
ILP1	6240-99-995-1225	Lamp, MES 6.5 V, 0.3 A			
S3		Mains Switch, part of RV15			
T1	5950-99-972-9205	Transformer, Output, LF			
T2	5950-99-972-9204	Transformer, Output, HF			
T3	5950-99-972-9206	Transformer, Mains (105-125 V/210-250 V 50-100 Hz)			
TH1	5905-99-940-3063	Thermistor, Type 1522/100, 100 k			
TH2	5905-99-972-8938	Thermistor, Type 1451/100, 10 k			
	5935-99-056-0031 or)	Holder, Valve			
	5935-99-056-0149)				
	5960-99-011-3581	Retainer, Valve			
† Adjusted on test.					

6625-99-195-4684 SIGNAL GENERATOR CT433ACOMPONENTS LIST

(Only differences shown)

Cot. Ref.	NSN or other Ref. No.	Description	Value	Tol. ± %	Rating
C4 C13	5910-99-105-5399 5910-99-972-2258	<u>CAPACITORS</u> Lemco, 1106R inc. Wima Type M	<u>µF</u> 27 p 0.22	5	<u>Volts</u> 400
R19 R23 R33 R34	5905-99-022-2055 5905-99-022-1150 5905-99-022-1190 5905-99-022-1106	<u>RESISTORS</u> Fixed, Composition, Grade 2, Insulated Fixed, Composition, Grade 2, Insulated Fixed, Composition, Grade 2, Insulated Fixed, Composition, Grade 2, Insulated	<u>Ohms</u> 2.7 k 220 470 100	5 5 5 5	<u>Watts</u> ½ ½ ½ ½
V1 V2 V3 V4	5960-99-000-2492 5960-99-000-4058 5960-99-000-2975 5960-99-000-4005	<u>VALVES, ELECTRONIC</u> CV2492 CV4058 CV2975 CV4005			
	5935-99-900-4654 5935-99-956-5981 5935-99-911-4433 5960-99-972-0101 5960-99-950-9189 5960-99-000-6788 5960-99-056-3007	<u>MISCELLANEOUS</u> Holder, Valve, V2, V4 Holder, Valve, V3 Holder, Valve, V1 Retainer, V2 Retainer, V4 Retainer, V3 Retainer, V1			

ILLUSTRATIONS

Signal Generator CT433
(Photograph facing Part 2B - Introduction)

Signal Generator CT433, 6625-99-943-4059 - Circuit Diagram

Signal Generator CT433A, 6625-99-195-4684 - Circuit Diagram

R	29	30	28	9	21	10	8	11	4	5	6	3	7	2	1	12	13	34	16	17	18	19	22	20	23	33	31	25	26	27	R
C	18	19	16	17	21	20	8	7	6	4	5	1	2	9	3	10	12	14	13	15											C
MISC	S3	T3	ILP1	V4	V1A	S1b	S1a	V1b	TH1	RV14	TH2	RV15	V2	S1c	RV24	V3	T1	T2	S1e	S1d	S2									MISC	

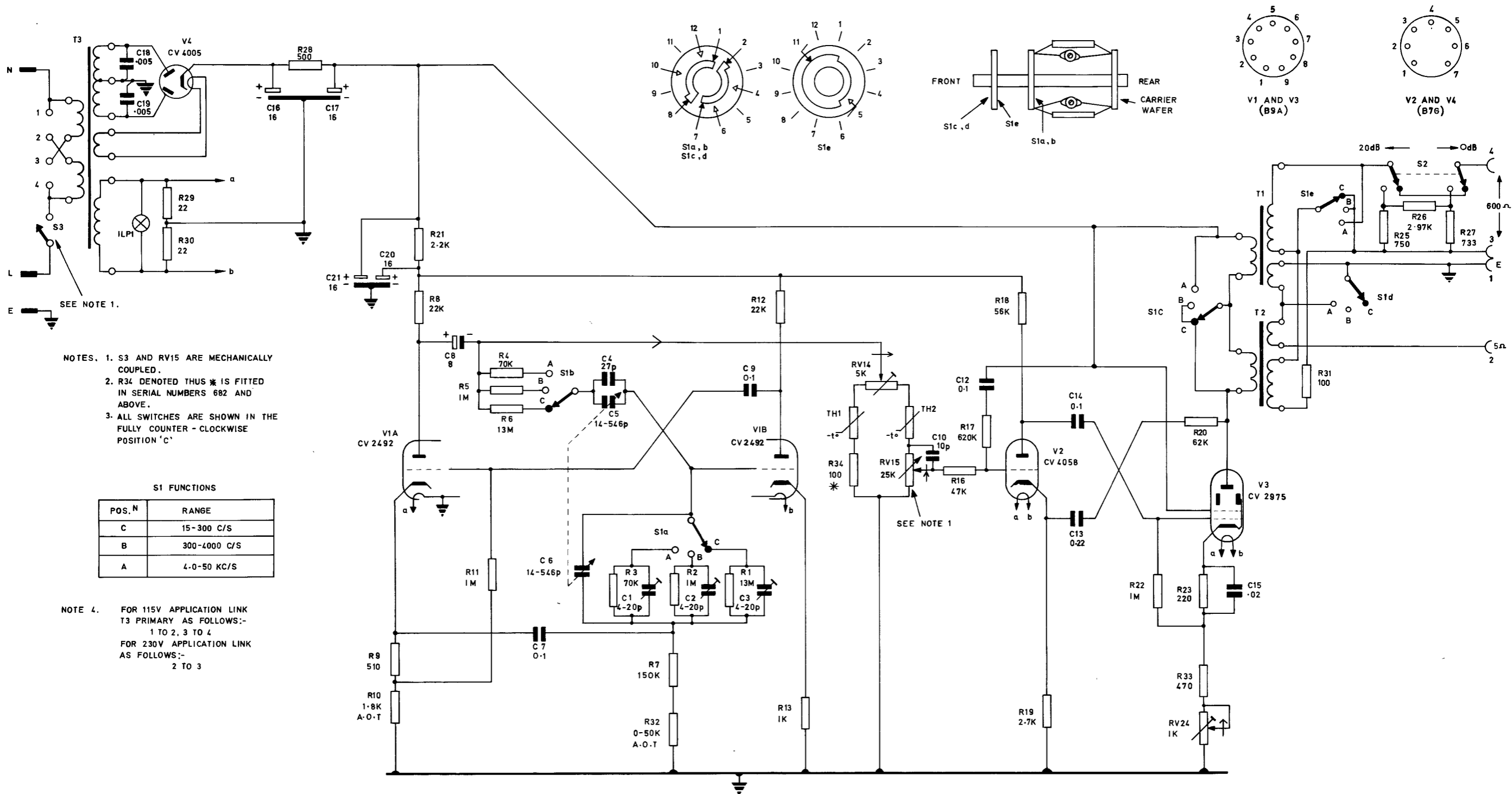

- NOTES. 1. S3 AND RV15 ARE MECHANICALLY COUPLED.
 2. R34 DENOTED THIS * IS FITTED IN SERIAL NUMBERS 682 AND ABOVE.
 3. ALL SWITCHES ARE SHOWN IN THE FULLY COUNTER - CLOCKWISE POSITION 'C'

S1 FUNCTIONS

POS. N	RANGE
C	15-300 C/S
B	300-4000 C/S
A	4.0-50 KC/S

NOTE 4. FOR 115V APPLICATION LINK T3 PRIMARY AS FOLLOWS:-
 1 TO 2, 3 TO 4
 FOR 230V APPLICATION LINK AS FOLLOWS:-
 2 TO 3

SIGNAL GENERATOR CT433 A
 6625-99-195-4684
 CIRCUIT DIAGRAM

FIG.3