

**As you are now the owner of this document which should have come to you for free, please consider making a donation of £1 or more for the upkeep of the (Radar) website which holds this document. I give my time for free, but it costs me around £300 a year to bring this document to you. You can donate here <https://blunham.com/Radar>, thank you.**

**Do not upload this copyright pdf document to any other website. Breaching copyright may result in a criminal conviction and large payment for Royalties.**

This document was generated by me, Colin Hinson, from a document held at R.A.F. Henlow Signals Museum which is believed to be out of copyright or Crown Copyright. It is presented here (for free) under the Open Government Licence (O.G.L.) if under Crown Copyright and this version of the document is my copyright (along with the Crown Copyright) in much the same way as a photograph would be. It should be noted that most of the pages are identifiable as having been processed by me. If you believe the original document to be under copyright, please contact me.

The document should have been downloaded from my website <https://blunham.com/Radar>, or any mirror site named on that site. If you downloaded it from elsewhere, please let me know (particularly if you were charged for it). You can contact me via my Genuki email page: <https://www.genuki.org.uk/big/eng/YKS/various?recipient=colin>

**You may not copy the file for onward transmission of the data nor attempt to make monetary gain by the use of these files. If you want someone else to have a copy of the file, point them at the website (<https://blunham.com/Radar>). Please do not point them at the file itself as it may move or the site may be updated.**

---

I put a lot of time into producing these files which is why you are met with this page when you open the file.

In order to generate this file, I need to scan the pages, split the double pages and remove any edge marks such as punch holes, clean up the pages, set the relevant pages to be all the same size and alignment. I then run Omnipage (OCR) to generate the searchable text and then generate the pdf file.

Hopefully after all that, I end up with a presentable file. If you find missing pages, pages in the wrong order, anything else wrong with the file or simply want to make a comment, please drop me a line (see above).

If you find the file(s) of use to you, you might like to make a donation for the upkeep of the website – see <https://blunham.com/Radar> for a link to do so.

*Colin Hinson*

*In the village of Blunham, Bedfordshire, UK.*

# 1415A TIME DOMAIN REFLECTOMETER

OPERATING AND SERVICE MANUAL

---

HEWLETT  PACKARD

---

## CERTIFICATION

*The Hewlett-Packard Company certifies that this instrument was thoroughly tested and inspected and found to meet its published specifications when it was shipped from the factory. The Hewlett-Packard Company further certifies that its calibration measurements are traceable to the U.S. National Bureau of Standards to the extent allowed by the Bureau's calibration facility.*

## WARRANTY AND ASSISTANCE

All Hewlett-Packard products are warranted against defects in materials and workmanship. This warranty applies for one year from the date of delivery, or, in the case of certain major components listed in the operating manual, for the specified period. We will repair or replace products which prove to be defective during the warranty period. No other warranty is expressed or implied. We are not liable for consequential damages.

For any assistance contact your nearest Hewlett-Packard Sales and Service Office. Addresses are provided at the back of this manual.



## OPERATING AND SERVICE MANUAL

# MODEL 1415A TIME DOMAIN REFLECTOMETER

SERIALS PREFIXED: 610-

See Section I For Instruments With Other Serial Prefixes

See Section I and Appendix I For Instruments With Options

Copyright      HEWLETT PACKARD COMPANY      1966  
1501 PAGE MILL ROAD, PALO ALTO, CALIFORNIA, U S A

**TABLE OF CONTENTS**

Section	Page	Section	Page
I	GENERAL INFORMATION . . . . .	5-9.	Front Panel Preliminary Settings . . . . .
	1-1. Description . . . . .	5-10.	Refl Coefficient Attenuator . . . . .
	1-4. Options . . . . .	5-11.	Distance/Time Scale . . . . .
	1-6. Manual Identification . . . . .	5-12.	Rise Time, Jitter, and Internal Reflections . . . . .
	1-8. Scope of Manual . . . . .	5-13.	Overshoot and Ringing . . . . .
II	INSTALLATION . . . . .	5-14.	Droop . . . . .
	2-1. Initial Inspection . . . . .	5-15.	Noise and Internal Pickup . . . . .
	2-4. Damage Claim and Repackaging . . . . .	5-16.	Output Impedance . . . . .
	2-7. Preparation for Use . . . . .	5-17.	Dynamic Range . . . . .
III	OPERATION . . . . .	5-18.	Adjustments . . . . .
	3-1. Introduction . . . . .	5-22.	Procedure . . . . .
	3-3. Controls and Connectors . . . . .	5-24.	Power Supply Adjustment . . . . .
	3-10. Operation . . . . .	5-25.	Step Stability Adjustment . . . . .
	3-13. Applications . . . . .	5-26.	Step Zero Level Adjustment . . . . .
IV	PRINCIPLES OF OPERATION . . . . .	5-27.	Sampler Diode Bias Adjustment . . . . .
	4-1. Introduction . . . . .	5-28.	Step Cal Adjustment . . . . .
	4-3. Circuit Details . . . . .	5-29.	Dist/Time Cal Adjustment . . . . .
	4-4. Step Generator . . . . .	5-30.	Dist/Time Cal Adjustment . . . . .
	4-9. Slow Ramp Generator . . . . .	5-31.	Time Scale Cal and 20-NSEC Time Scale Cal Adjustments . . . . .
	4-13. Dot Generator . . . . .	5-32.	Time Scale Cal Adjustment . . . . .
	4-17. Fast Ramp Generator . . . . .	5-36.	Dot Delay Adjustment . . . . .
	4-19. Ramp Comparator . . . . .	5-37.	Zero Set Adjustments . . . . .
	4-21. Sampler . . . . .	5-38.	Pulse Shape Adjustment . . . . .
	4-23. Vertical Amplifier . . . . .	5-39.	Troubleshooting . . . . .
	4-25. Horizontal Amplifier . . . . .	5-42.	General Troubleshooting . . . . .
	4-27. Power Supply . . . . .	5-50.	Specific Troubleshooting . . . . .
V	MAINTENANCE . . . . .	5-52.	Component Location . . . . .
	5-1. Introduction . . . . .	5-54.	Servicing Etched Circuit . . . . .
	5-3. Performance Check . . . . .	VI	REPLACEABLE PARTS . . . . .
	5-5. Test Equipment . . . . .	6-1.	Introduction . . . . .
	5-7. Procedure . . . . .	6-3.	Ordering Information . . . . .
		APPENDIX I.	OPTIONS . . . . . IA-1/IA-2
		APPENDIX II.	MANUAL CHANGES . . . . . IIA-1

**LIST OF ILLUSTRATIONS**

Number	Title	Page	Number	Title	Page
1-1.	Model 1415A Time Domain Reflectometer	1-0	5-13.	Waveforms at Test Points in Fast Ramp and Comparator Circuits	5-14
3-1.	Model 1415A Controls and Connectors	3-2	5-14.	Fast Ramp and Comparator Schematic Diagram	5-15
3-2.	Initial Operation	3-3	5-15.	Component Locations on Sampler Block Assembly	5-16
3-3.	Vertical Calibration	3-4	5-16.	Component Locations on A3, Sampler Board	5-16
3-4.	Horizontal Calibration	3-5	5-17.	Waveforms at Test Points in Sampler Circuit	5-16
3-5.	Reflection Measurements	3-6	5-18.	Sampler Schematic Diagram	5-17
3-6.	Transmission Measurements	3-7	5-19.	Component Locations on A5, Amplifier Board	5-18
4-1.	Step Generator, and Fast Ramp and Comparator Block Diagram	4-0	5-20.	Component Locations on A7, Trimmer Board	5-18
4-2.	Model 1415A Block Diagram	4-1	5-21.	Component Locations on A8, Reflection Coefficient Switch	5-18
4-3.	Horizontal Amplifier, and Slow Ramp and Dot Comparator Block Diagram	4-2	5-22.	Horizontal Amplifier Schematic Diagram	5-18
4-4.	Sampler and Vertical Amplifier Block Diagram	4-4	5-23.	Vertical Amplifier Schematic Diagram	5-19
5-1.	Location of Adjustments	5-3	5-24.	Power Supply Schematic Diagram	5-20
5-2.	Model 1415A Component Location, Top View	5-9	5-25.	Component Locations on A6, Power Supply Board	5-20
5-3.	Model 1415A Component Location, Bottom View	5-9	5-26.	Interconnection Plugs Schematic Diagram	5-20
5-4.	Component Locations on A2, Pulse Generator Board	5-10	IA-1.	Components Locations on A9, Option 14	IA-1/IA-2
5-5.	Waveforms at Test Points in Step Generator Circuit	5-10	IA-2.	Option 14 Distance/Time Switch Schematic	IA-3/IA-4
5-6.	Step Generator Schematic Diagram	5-11	IIA-1.	Controls and Connectors	IIA-7/IIA-8
5-7.	Component Locations on A10, Distance/Time Magnifier Switch	5-12	IIA-2.	Time Base Board A1	IIA-9/IIA-10
5-8.	Component Locations on A13, Sweep Switch	5-12	IIA-3.	Partial Schematic, Slow Ramp and Dot Comparator	IIA-9 /IIA-10
5-9.	Component Locations on A1, Time Base Board	5-12	IIA-4.	Amplifier Board A5	IIA-11/IIA-12
5-10.	Waveforms at Test Points in Slow Ramp and Dot Comparator Circuits	5-12	IIA-5.	Trimmer Board A7	IIA-11/IIA-12
5-11.	Slow Ramp and Dot Comparator Schematic Diagram	5-13	IIA-6.	Power Supply Board A6	IIA-11/IIA-12
5-12.	Component Locations on A9, Distance/Time CM Line/CM Display Switch	5-14	IIA-7.	Q101 Emitter Circuit	IIA-11/IIA-12
			IIA-8.	Pulse Generator Board A2	IIA-11/IIA-12
			IIA-9.	Pulse Shape Adjust Circuit	IIA-11/IIA-12

**LIST OF TABLES**

Number	Title	Page	Number	Title	Page
1-1.	Specifications	1-0	5-6.	Schematic Diagram Notes	5-8
5-1.	Equipment Required for Tests and Adjustments	5-0	6-1.	Reference Designation Index	6-2
5-2.	Vertical Magnifier Check	5-1	6-2.	Replaceable Parts	6-15
5-3.	Distance/Time Scale Check	5-2	6-3.	Code List of Manufacturers	6-20
5-4.	Specific Troubleshooting	5-7	IA-1.	Option 14 Replaceable Parts	IA-0
5-5.	Conditions for Waveform and DC Voltage Measurements	5-8	IIA-1.	Reference Designation Index and Replaceable Parts	IIA-5/IIA-6

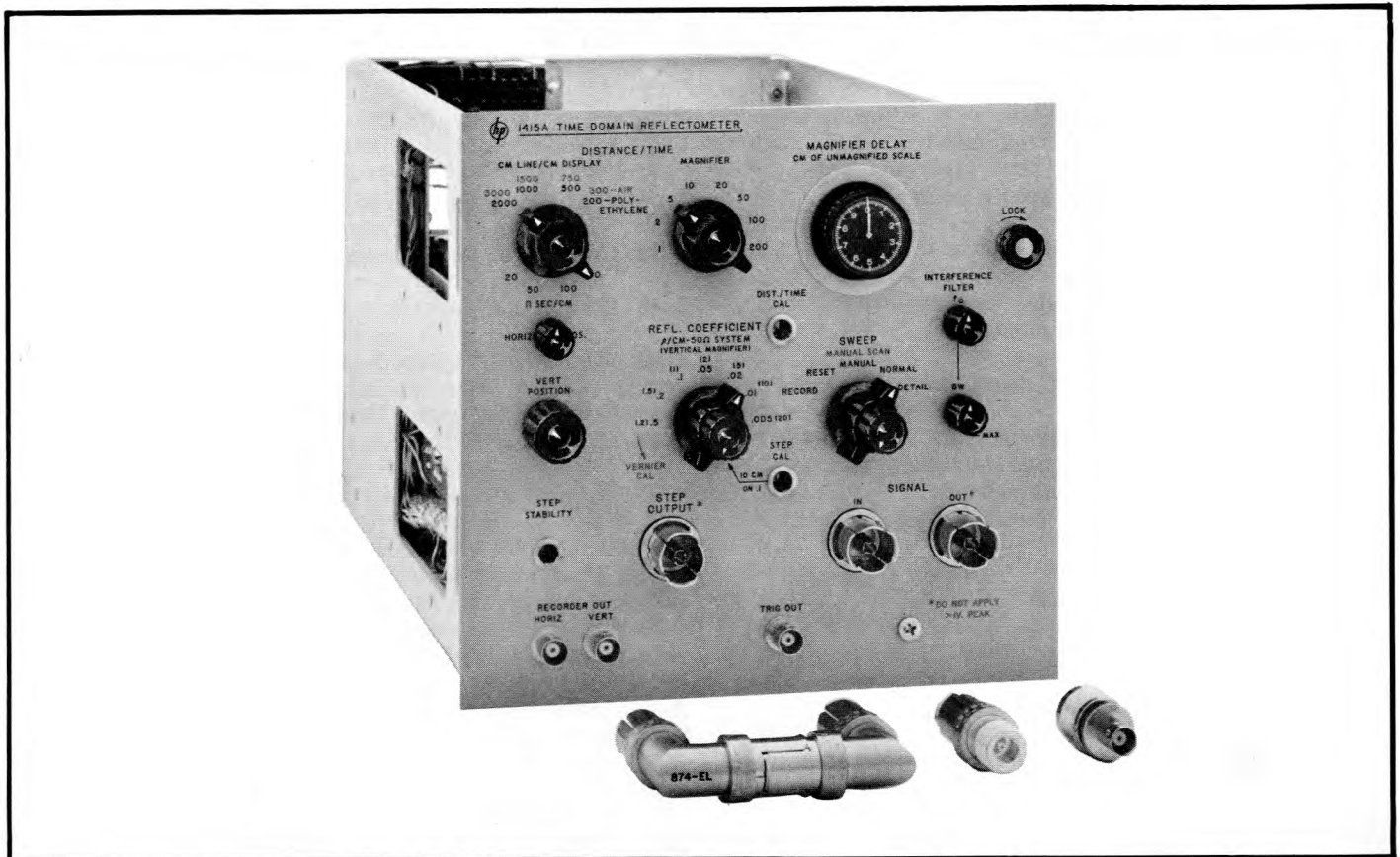

Figure 1-1. Model 1415A Time Domain Reflectometer

Table 1-1. Specifications

**SYSTEM** (in reflectometer configuration)

- RISE TIME: Less than 150 psec.
- OVERSHOOT: 5% or less overshoot and ringing (down to 1/2% in 2 nsec).
- INTERNAL REFLECTIONS: Less than 10% (does not limit resolution).
- REFLECTOMETER SENSITIVITY: Reflection coefficients as small as 0.001 can be observed.
- REPETITION RATE: 150 kc nominal.

**SIGNAL CHANNEL**

- RISE TIME: Approximately 110 psec.
- REFLECTION COEFFICIENT: 0.5/cm to 0.005/cm in 1, 2, 5 sequence.
- INPUT: 50 ohms, feed-through type.
- NOISE AND INTERNAL PICKUP, PEAK: 0.1% of step (terminated in 50 ohms).
- DYNAMIC RANGE:  $\pm 0.5$  volt.
- EXTERNAL SIGNAL LEVEL: Up to 1 v peak may be safely applied to the SIGNAL OUT connector.
- ATTENUATOR ACCURACY:  $\pm 3\%$ .

**STEP GENERATOR**

- AMPLITUDE: Approximately 0.25 v into 50 ohms (0.5 v into open circuit).
- RISE TIME: Approximately 50 psec.
- OUTPUT IMPEDANCE: 50 ohms  $\pm 1$  ohm.

DROOP: Less than 1%.

**DISTANCE/TIME SCALE**

- DISTANCE SCALE ACCURACY (cm of Line/cm of Display): 5%.
- POLYETHYLENE LINE ( $\epsilon = 2.25$ ): 200 cm/cm to 2000 cm/cm.
- AIR LINE ( $\epsilon = 1$ ): 300 cm/cm to 3000 cm/cm.
- TIME SCALE: 20 to 200 nsec/cm,  $\pm 5\%$  accuracy.
- MAGNIFICATION: X1 to X200 in 1, 2, 5 sequence. Accuracy of the basic sweep is maintained at all magnifier settings with the exception of time represented by the first 0.1 cm of the unmagnified sweep after start of the step.
- DELAY CONTROL: 0 to 10 cm of unmagnified sweep, calibrated.
- JITTER: Less than 20 psec.

**ACCESSORIES FURNISHED**

DESCRIPTION	QUANTITY
GR Elbow (EL connector)	2
GR to type N adapter	1
BNC to type N adapter	1

**POWER**

Supplied by Oscilloscope.

**WEIGHT**

Net, 7 lbs. (3, 2 kg).

## SECTION I GENERAL INFORMATION

### 1-1. DESCRIPTION.

1-2. The  $\text{hp}$  Model 1415A Time Domain Reflectometer, a double-size plug-in unit for the  $\text{hp}$  Model 140-series Oscilloscopes, is a completely integrated transmission line testing system. The unit includes both the time base and vertical deflection functions of a high-speed sampling oscilloscope, and a fast-rise step generator. The Model 1415A locates and determines the magnitude and nature of discontinuities in high-frequency transmission systems, and can be used to measure the quality of broadband systems.

1-3. The technique of time domain reflectometry, for which the Model 1415A is specifically designed, consists essentially of applying a voltage step to the transmission system and observing the reflections. A reflection occurs each time the step encounters an impedance mismatch (discontinuity); this reflection is added to the incident wave and is displayed on the CRT of the oscilloscope. The time required for the reflection to return to the sampler in the Model 1415A locates the discontinuity. The shape and magnitude of the reflected wave indicate the nature and value of the mismatch, which can be resistive, inductive, or capacitive. In general, an inductive discontinuity reflects a voltage spike having the same polarity as the incident step, and a capacitive discontinuity reflects a voltage spike of the opposite polarity. A resistive discontinuity having a value larger than the line impedance reflects a step of the same polarity as the incident step, and a step of the opposite polarity is reflected if the value is less than the line impedance. Detailed discussions on evaluating reflections observed are given in  $\text{hp}$  Application Notes 62 and 67, which are supplied with the Model 1415A.

### 1-4. OPTIONS.

1-5. There is one option available for the Model 1415A. This option (Option 14) provides an additional position for the DISTANCE/TIME switch. This added position is equal to 1000 nsec/cm expressed in time, or 10,000 CM LINE/CM DISPLAY (polyethylene) and 15,000 CM LINE/CM DISPLAY (air) expressed in distance. Refer to Appendix I for complete information on this option.

### 1-6. MANUAL IDENTIFICATION.

1-7. Information in this manual applies directly to Model 1415A instruments with a serial prefix of 610- (see manual title page). The serial prefix of a  $\text{hp}$  instrument is the first three digits (i. e. those before the dash, as 000-00000) of the serial number stamped on a plate attached to the rear panel. Appendix II contains information on changes required to adapt this manual to an instrument with the serial prefixes listed there. A separate changesheet (included with this manual) provides information to adapt this manual to an instrument with any serial prefix other than those listed in Appendix II. Any errors in this manual when it was printed are called Errata, and these corrections will appear only on the separate change sheet included.

### 1-8. SCOPE OF MANUAL.

1-9. This manual supplies operating and maintenance instructions for the Model 1415A Time Domain Reflectometer. The information in this manual supplements the manual for the oscilloscope with which the Model 1415A is used. Refer to the Oscilloscope manual for specifications and instructions which apply specifically to that instrument.

## SECTION II INSTALLATION

### 2-1. INITIAL INSPECTION.

2-2. **MECHANICAL CHECK.** If external damage to the shipping carton is evident, ask the carrier's agent to be present when the instrument is unpacked. Check the instrument for external damage such as broken controls or connectors, and dents or scratches on the panel surface. If damage is evident, see Paragraph 2-4 for recommended claim procedure and repackaging information. If the shipping carton is not damaged, check the cushioning material and note any signs of severe stress as an indication of rough handling in transit. If the instrument appears undamaged, perform the electrical check (see Paragraph 2-3).

2-3. **ELECTRICAL CHECK.** Check the electrical performance of the Model 1415A as soon as possible after receipt. Paragraphs 5-3 through 5-17 contain performance check procedures which will verify in-

strument operation within the specifications listed in Table 1-1. This check is also suitable for incoming quality control inspection. If the Model 1415A does not perform within the specifications when received, refer to Paragraph 2-4 for recommended claim procedure and repackaging information.

### 2-4. DAMAGE CLAIM AND REPACKAGING.

2-5. If physical damage is evident, or if the instrument does not meet specifications when received, notify the carrier and the nearest Hewlett-Packard Sales/Service Office (see list at rear of this manual). The Sales/Service Office will arrange for repair or replacement without waiting for settlement of a claim with the carrier.

2-6. The original shipping carton and packing material, with the exception of accordion-pleated pads, should be

## Paragraphs 2-7 and 2-8.

used for reshipment. The accordion-pleated pads are fatigued with one use and are not reusable. The Hewlett-Packard Sales Service Office will also provide information and recommendations on materials to be used if the original packaging material is not available or reusable. Materials used should include: (1) a double-walled carton (check with a freight carrier for test strength required), (2) heavy paper or sheets of cardboard to protect all instrument surfaces; use extra material around projecting parts of the instrument, (3) at least four inches of tightly-packed shock-absorbing material surrounding the instrument. Close the carton securely with durable shipping tape. If the instrument is to be shipped to a Sales Service Office

for repair, attach a tag showing owner, model, serial and repairs required.

**2-7. PREPARATION FOR USE.**

2-8. The Model 1415A is a double-size plug-in unit for the Model 140-series oscilloscopes, and is intended to be used in place of two normal-size plug-ins. To install the Model 1415A, remove the dividing shield between the upper and lower compartments by pulling straight out, slide the Model 1415A into place, and secure by turning the LOCK knob clockwise. All necessary connections to the Oscilloscope are automatically completed when the unit is installed and locked in place.

## SECTION III OPERATION

### 3-1. INTRODUCTION.

3-2. This section contains information on the function of all controls in the Model 1415A Time Domain Reflectometer and on the basic operation of the instrument. Refer to the oscilloscope manual for instructions on operating CRT display controls.

### 3-3. CONTROLS AND CONNECTORS.

3-4. Figure 3-1 identifies and briefly describes the Model 1415A controls and connectors. To aid in proper operation, Paragraphs 3-5 through 3-9 provide a more extensive description of some controls.

3-5. **DISTANCE/TIME CM LINE/CM DISPLAY.** The four settings on this switch are calibrated both in nanoseconds per centimeter, and in centimeters of external transmission line per centimeter of display. Values are indicated for the two most common types of transmission line, polyethylene dielectric (black numerals) and air dielectric (red numerals).

3-6. **DISTANCE/TIME MAGNIFIER.** The eight settings on this switch indicate horizontal display magnification from X1 to X200. These settings are used as division factors for **DISTANCE in CM LINE/CM DISPLAY** or for **TIME in NSEC/CM**. The display expands around the point selected by the **MAGNIFIER DELAY** control, which is indicated by a brightened spot on the display.

3-7. **MAGNIFIER DELAY.** This 10-turn potentiometer is calibrated in tenths of millimeters from 0 to 10 centimeters, and uses a brightened dot on the display as an indicator; e. g., dot is midscreen with **MAGNIFIER DELAY** set at 5.00 centimeters. The reading on the control is used to calculate distance or time in conjunction with the basic **DISTANCE/TIME** setting only, but is independent of the **DISTANCE/TIME MAGNIFIER** setting.

3-8. **SWEEP.** Horizontal scan modes of the instrument are selected by this five position switch as follows: **RECORD** position provides the signal to drive an external recorder through the **RECORDER OUT** jacks; **RESET** position resets the recorder sweep to zero; **MANUAL** position sets up the **MANUAL SCAN** control for manual scanning of the input signal (also helpful for calibrating the external recorder); **NORMAL** position is used for normal scanning of the input signal (about 3000 samples per sweep, repetition rate of 50 cps); and **DETAIL** position which provides a higher sampling density for a more detailed sweep (about 30,000 samples per sweep, repetition rate of 5 cps).

3-9. **REFL COEFFICIENT (VERTICAL MAGNIFIER).** Vertical scale of the instrument is determined by this control as follows: directly in reflection coefficient

reading per centimeter; or (in parenthesis) in vertical magnification from X0.2 to X20, referenced to a step amplitude of 10 cm at X1. Calibration of the reflection coefficient assumes a 50-ohm external system. The **VERNIER** control provides variable adjustment between steps.

### 3-10. OPERATION.

3-11. **GENERAL.** Figures 3-2 through 3-6 give step-by-step procedures for operating the Model 1415A. The vertical and horizontal calibration adjustments should be done whenever the Model 1415A is operated in an oscilloscope other than the one in which it was previously adjusted; this includes first-time operation. A periodic check of these adjustments is also recommended even when the Model 1415A is used in only one oscilloscope.

3-12. **ELIMINATION OF RF INTERFERENCE.** The CRT display may become distorted due to RFI when the instrument is used to test antennas or long transmission lines, since these elements tend to act as receiving antennas for any RF in the area. When a narrow band RFI problem exists, it can be eliminated by adjusting the  $f_c$  (interference filter center frequency) control. If the RFI is of a broad band nature, the  $f_c$  control is adjusted for minimum interference, then the **BW** (interference filter bandwidth) control is adjusted for further elimination of the interference. Normally, the instrument is operated with the **BW** control in the **MAX** position. If the **BW** control is adjusted away from the **MAX** position, the Model 1415A must be switched to the **DETAIL** mode of operation to avoid seriously degrading the vertical presentation. These effects are quite obvious when viewing the CRT presentation. In addition, a shorter and shorter time scale setting is required as the **BW** control is turned towards minimum if no degrading of the vertical presentation can be tolerated. This is not a serious limitation, since any portion of the longer time scale can be observed by adjusting the magnifier and delay controls.

### 3-13. APPLICATIONS.

3-14. The Model 1415A has been designed specifically for time domain reflectometry, a measurement technique offering the most convenient method for gaining valuable information on most types of transmission line systems. To describe this technique and its applications,  Application Notes 62 and 67 have been prepared. These application notes discuss the fundamentals of transmission line measurements, and give practical measuring considerations. The user is referred to these publications. Copies may be obtained from your Hewlett-Packard Sales/Service Office.

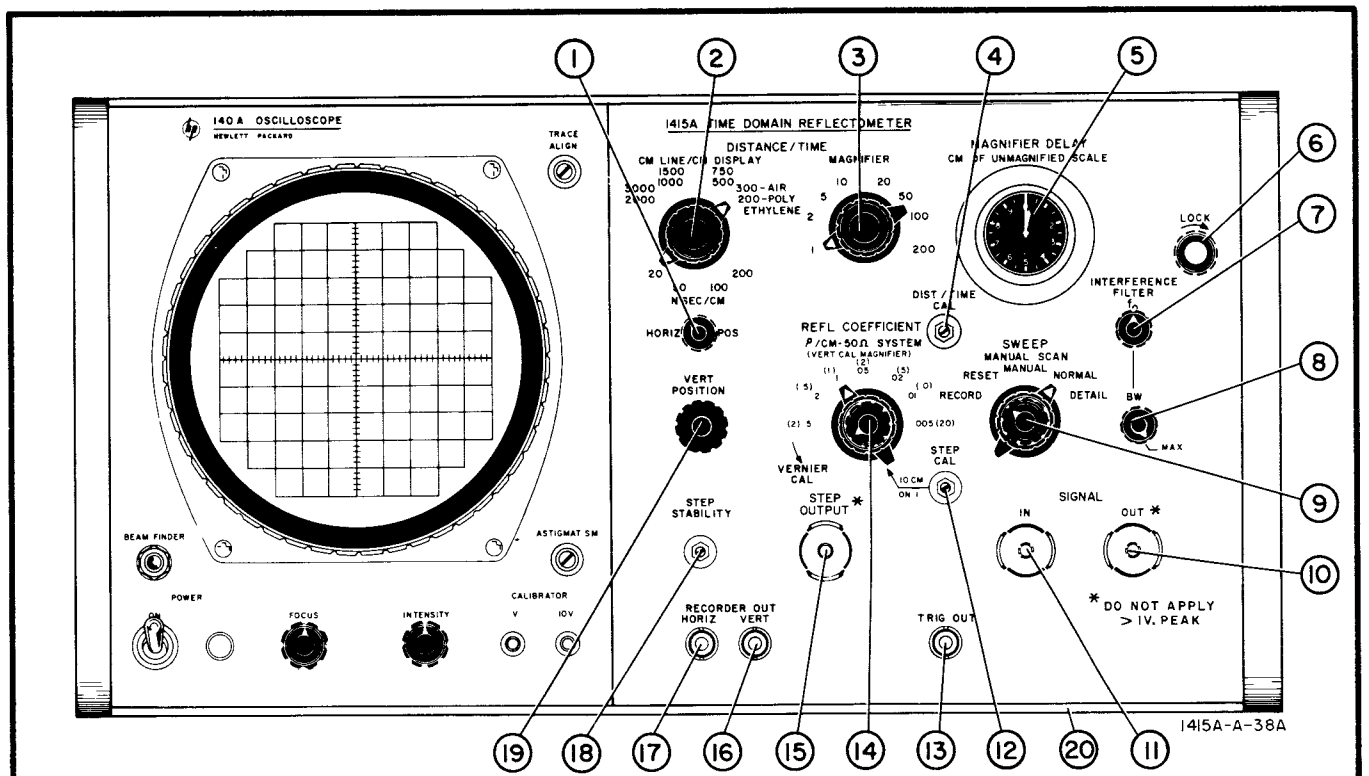

- ① **HORIZ POS.** Sets the horizontal position of the display on the oscilloscope graticule. (Does not require frequent adjustment.)
- ② **DISTANCE/TIME CM LINE/CM DISPLAY.** Adjusts the basic time and distance scales. (See Par. 3-5)
- ③ **DISTANCE/TIME MAGNIFIER.** Expands basic time and distance scales. (See Par. 3-6)
- ④ **DIST/TIME CAL.** Sets time and distance scales calibration to compensate for slight differences in oscilloscope CRT deflection plate sensitivities.
- ⑤ **MAGNIFIER DELAY.** Determines horizontal separation between any points on the display in centimeters. (See Par. 3-7)
- ⑥ **LOCK.** Rotate LOCK knob clockwise to mechanically secure Model 1415A in oscilloscope.
- ⑦ **INTERFERENCE FILTER  $f_0$ .** Eliminates narrow band RF interference. (See Par. 3-12)
- ⑧ **INTERFERENCE FILTER BW.** Used in conjunction with the  $f_0$  control to reduce or eliminate broad band RF interference. (See Par. 3-12)
- ⑨ **SWEEP.** Selects various horizontal scan modes. (See Par. 3-8)
- ⑩ **SIGNAL OUT.** Provides connection for the external system in reflection measurements, or a termination in transmission systems.
- ⑪ **SIGNAL IN.** Provides connection for the step input in reflection measurements, or input signal from a transmission system.
- ⑫ **STEP CAL.** Calibrates vertical sensitivity of the Model 1415A to compensate for slight differences in oscilloscope CRT deflection plate sensitivities.
- ⑬ **TRIG OUT.** Provides a delayed negative trigger output to trigger external step generator, such as *hp* Model 215A Pulse Generator.
- ⑭ **REFL COEFFICIENT (VERTICAL MAGNIFIER).** Determines the vertical scale. (See Par. 3-9)
- ⑮ **STEP OUTPUT.** Supplies the negative step output (amplitude about 0.25 volts into a 50-ohm system). The display is normally inverted for negative-up presentation.
- ⑯ **RECORDER OUT VERT.** Supplies vertical deflection signal for an X-Y recorder. Output voltage is approximately 0.8 volts per centimeter of screen deflection; approximately 0 volts with the trace centered.
- ⑰ **RECORDER OUT HORIZ.** Supplies horizontal scan voltage for an X-Y recorder. Output voltage is approximately +2 volts with beam at left edge of graticule, and +18 volts with beam at right edge of graticule.
- ⑱ **STEP STABILITY.** Adjusts the stability of the output step pulses for minimum pulse jitter.
- ⑳ **VERT POSITION.** Adjusts the vertical position of the display on the oscilloscope screen.
- ㉑ **NEG UP/POS UP.** (Located on bottom of Model 1415A.) Selects either negative-up or positive-up presentation of the display on the oscilloscope CRT screen.

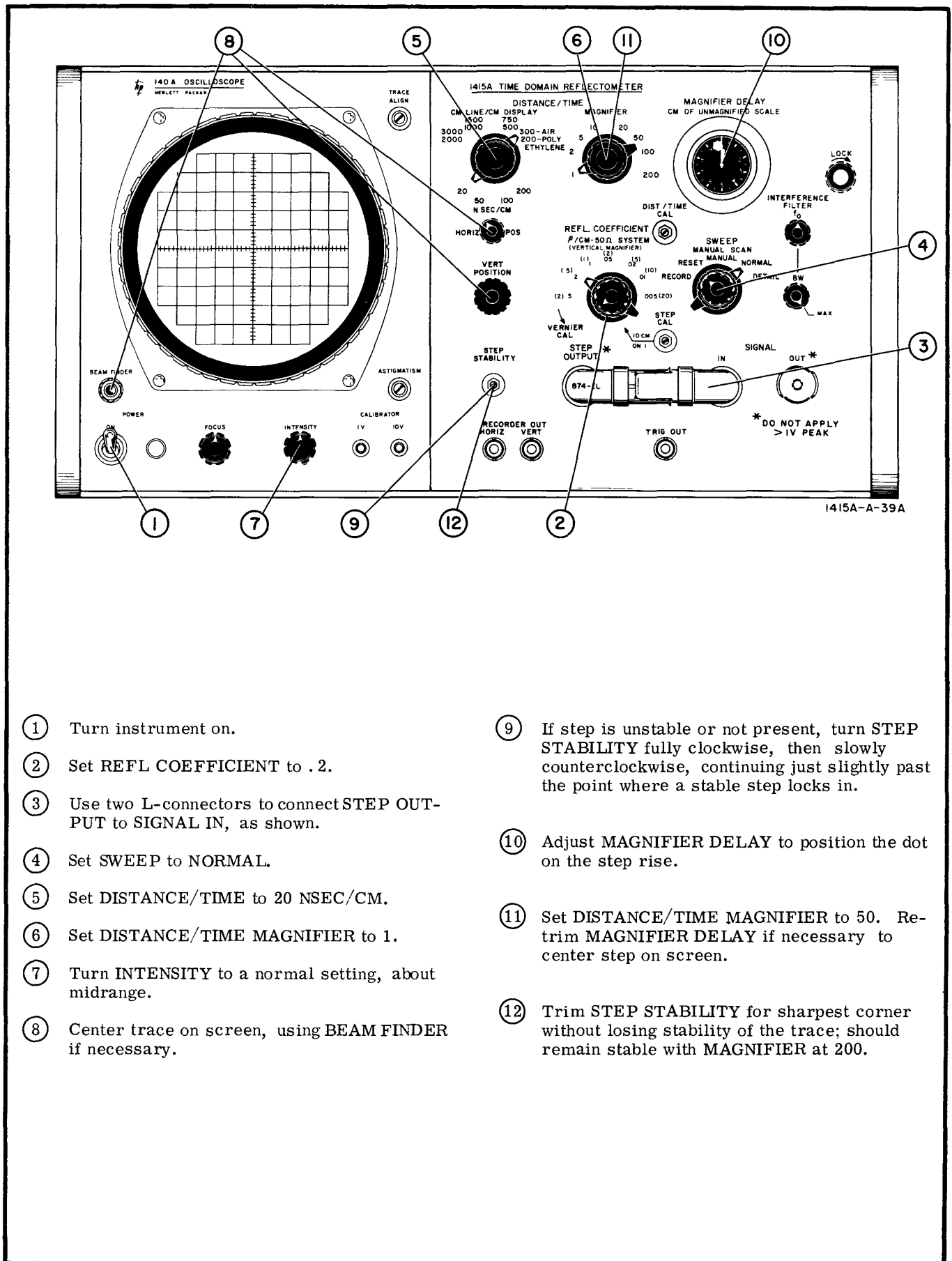

- ① Turn instrument on.
- ② Set REFL COEFFICIENT to .2.
- ③ Use two L-connectors to connect STEP OUTPUT to SIGNAL IN, as shown.
- ④ Set SWEEP to NORMAL.
- ⑤ Set DISTANCE/TIME to 20 NSEC/CM.
- ⑥ Set DISTANCE/TIME MAGNIFIER to 1.
- ⑦ Turn INTENSITY to a normal setting, about midrange.
- ⑧ Center trace on screen, using BEAM FINDER if necessary.
- ⑨ If step is unstable or not present, turn STEP STABILITY fully clockwise, then slowly counterclockwise, continuing just slightly past the point where a stable step locks in.
- ⑩ Adjust MAGNIFIER DELAY to position the dot on the step rise.
- ⑪ Set DISTANCE/TIME MAGNIFIER to 50. Re-trim MAGNIFIER DELAY if necessary to center step on screen.
- ⑫ Trim STEP STABILITY for sharpest corner without losing stability of the trace; should remain stable with MAGNIFIER at 200.

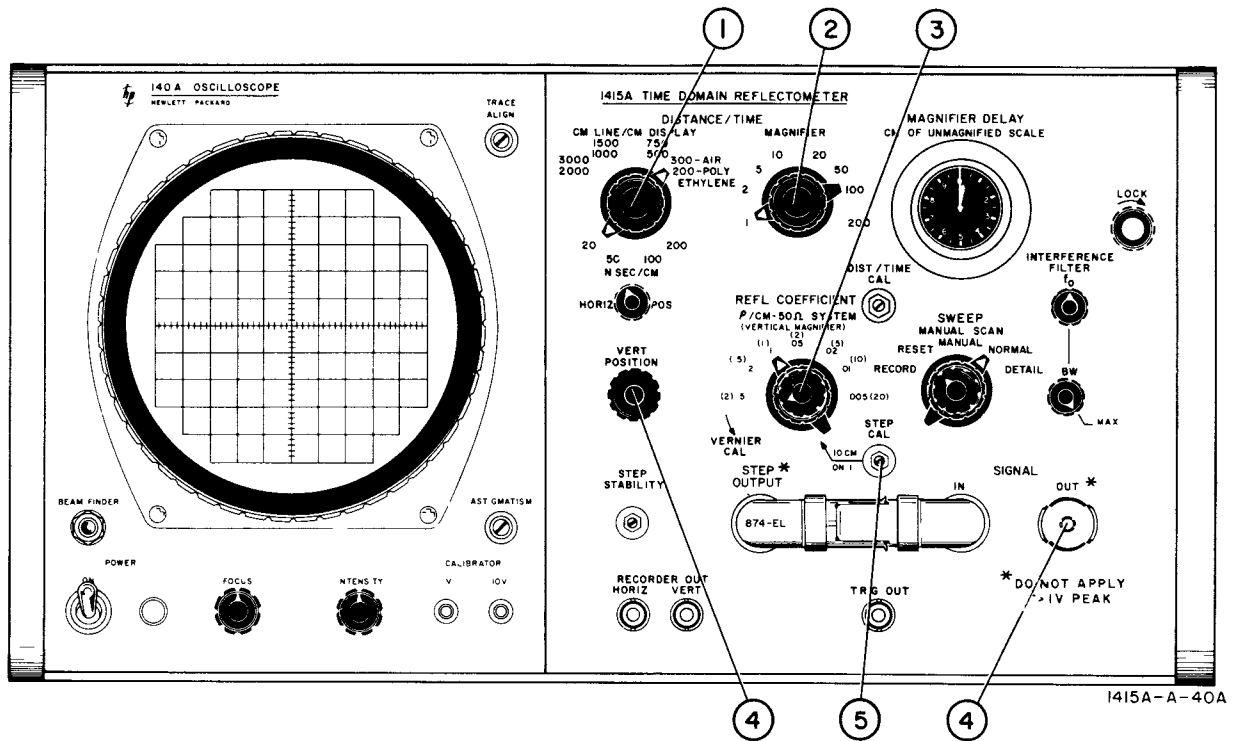

- ① Set DISTANCE/TIME to 20 NSEC/CM.
- ② Set DISTANCE/TIME MAGNIFIER to 1.
- ③ Set REFL COEFFICIENT to .1, with VERNIER in CAL.
- ④ Position base line of display on bottom graticule line. Connect 50-ohm load,  $\pm 1\%$ , to SIGNAL OUT.
- ⑤ Adjust STEP CAL for a step amplitude of exactly 10 centimeters.

Figure 3-3. Vertical Calibration

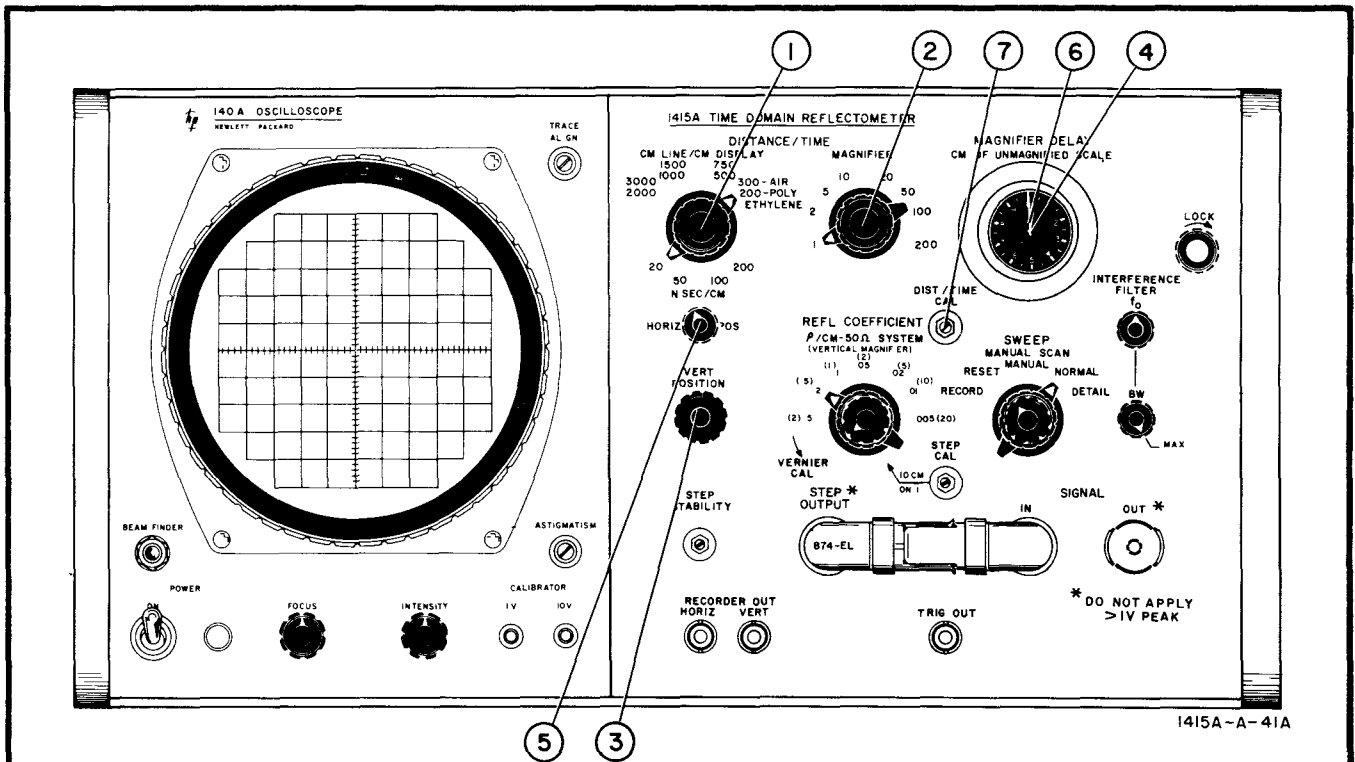

- ① Set DISTANCE/TIME to 20 NSEC/CM.
- ② Set DISTANCE/TIME MAGNIFIER to 1.
- ③ Center display vertically. (An input signal is not required for this adjustment.)
- ④ Set MAGNIFIER DELAY to 0.00.
- ⑤ Adjust HORIZ POS to position the dot exactly over the 0-cm (left edge) graticule line.
- ⑥ Turn MAGNIFIER DELAY to 10.00.
- ⑦ If dot is not exactly over the 10-cm (right edge) graticule line, adjust DIST/TIME CAL to position the dot half-way between its present position and the 10-cm graticule line.
- 8 Repeat steps 4 through 7 until MAGNIFIER DELAY reads 0.00 at the 0-cm graticule line and 10.00 at the 10-cm graticule line.

Figure 3-4. Horizontal Calibration

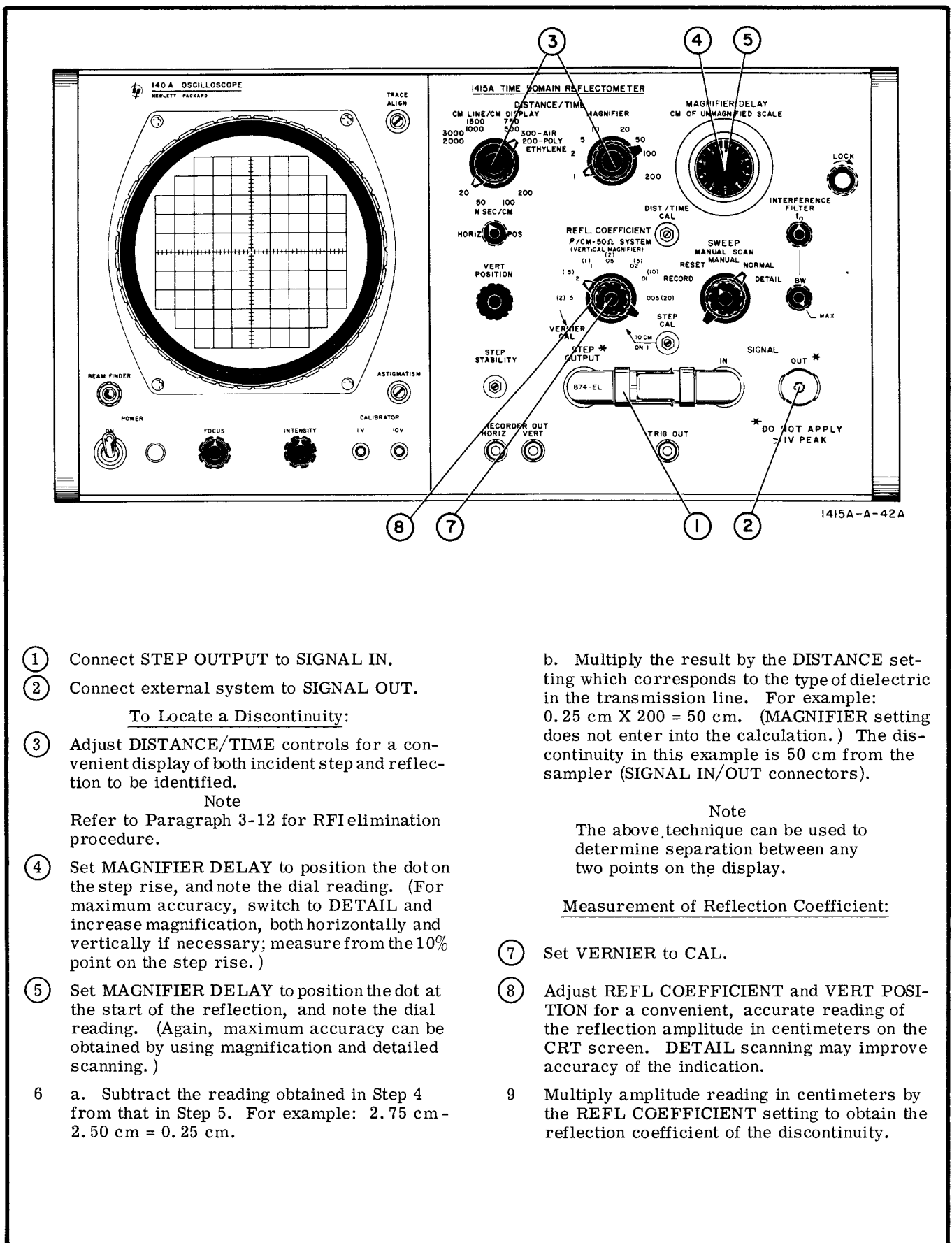

- ① Connect STEP OUTPUT to SIGNAL IN.
  - ② Connect external system to SIGNAL OUT.
- To Locate a Discontinuity:
- ③ Adjust DISTANCE/TIME controls for a convenient display of both incident step and reflection to be identified.  
 Note  
 Refer to Paragraph 3-12 for RFI elimination procedure.
  - ④ Set MAGNIFIER DELAY to position the dot on the step rise, and note the dial reading. (For maximum accuracy, switch to DETAIL and increase magnification, both horizontally and vertically if necessary; measure from the 10% point on the step rise.)
  - ⑤ Set MAGNIFIER DELAY to position the dot at the start of the reflection, and note the dial reading. (Again, maximum accuracy can be obtained by using magnification and detailed scanning.)
- 6 a. Subtract the reading obtained in Step 4 from that in Step 5. For example: 2.75 cm - 2.50 cm = 0.25 cm.

b. Multiply the result by the DISTANCE setting which corresponds to the type of dielectric in the transmission line. For example: 0.25 cm X 200 = 50 cm. (MAGNIFIER setting does not enter into the calculation.) The discontinuity in this example is 50 cm from the sampler (SIGNAL IN/OUT connectors).

Note  
 The above technique can be used to determine separation between any two points on the display.

Measurement of Reflection Coefficient:

- ⑦ Set VERNIER to CAL.
- ⑧ Adjust REFL COEFFICIENT and VERT POSITION for a convenient, accurate reading of the reflection amplitude in centimeters on the CRT screen. DETAIL scanning may improve accuracy of the indication.
- 9 Multiply amplitude reading in centimeters by the REFL COEFFICIENT setting to obtain the reflection coefficient of the discontinuity.

Figure 3-5. Reflection Measurements

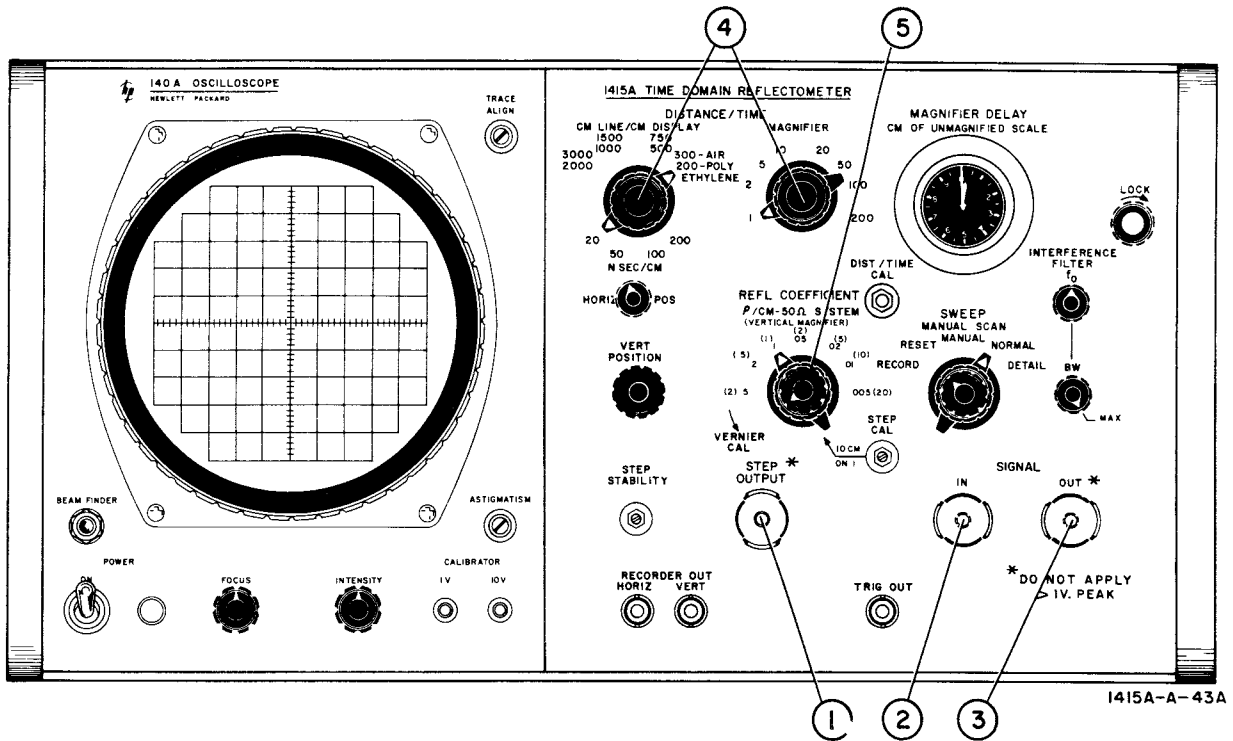

**CAUTION**

Do not connect the 1415A into any system which produces voltage levels in excess of 1.0 volt peak into 50 ohms.

- ① Connect STEP OUTPUT to input of external system (may be active or passive).
- ② Connect output of external system to SIGNAL IN (signal amplitude not to exceed  $\pm 0.5$  volts).
- ③ Connect a 50-ohm termination (such as GR 874-W50) to SIGNAL OUT.
- ④ Use TIME settings in NSEC/CM, as with a conventional oscilloscope, to determine the time phenomena (e.g., rise and fall times of the external system).  
 Note  
 Refer to Paragraph 3-12 for RFI elimination procedure.
- ⑤ Use VERTICAL MAGNIFIER to determine amplification or attenuation of the external system.

Figure 3-6. Transmission Measurements

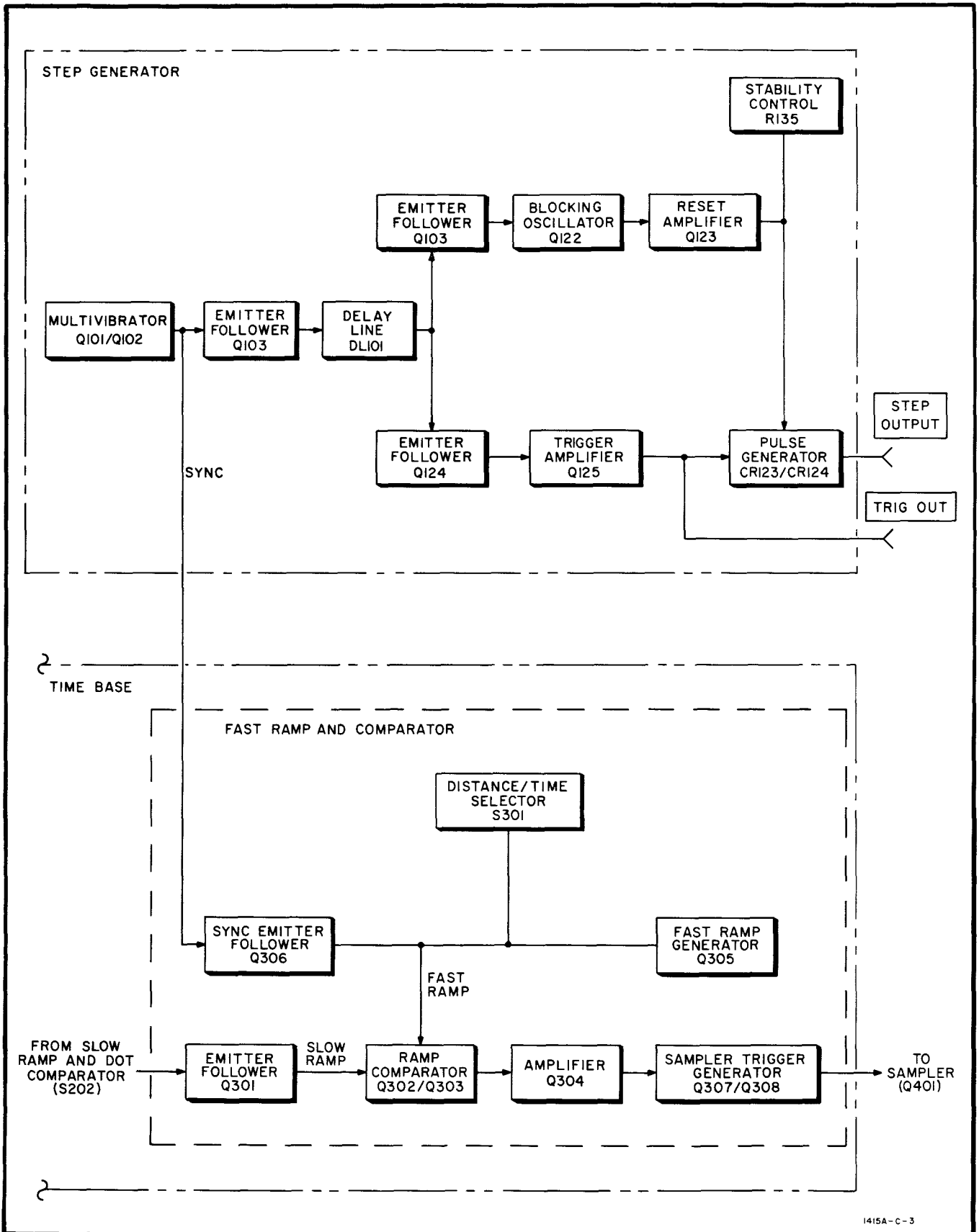

1415A-C-3

Figure 4-1. Step Generator, and Fast Ramp and Comparator Block Diagram

## SECTION IV

### PRINCIPLES OF OPERATION

#### 4-1. INTRODUCTION.

4-2. The  $\frac{1}{2}$  Model 1415A Time Domain Reflectometer consists of a fast-rise step generator, a time base circuit, a horizontal amplifier, a sampling circuit, and a single-channel vertical amplifier. The relationship of these circuits is shown in Figure 4-2. Basic operation is as follows: The step generator, producing pulses at the rate of about 150 kc, triggers the time base circuit and applies a step waveform through a 50-ohm bridging sampler to the system under test. Reflections from the external system add to the incident step, and are sampled and amplified by the vertical amplifier for display on the oscilloscope's CRT screen.

#### 4-3. CIRCUIT DETAILS.

##### 4-4. STEP GENERATOR.

4-5. The step generator, Figures 4-1 and 5-6, performs three functions: 1) provides an undelayed sync pulse to trigger the fast ramp; 2) provides a delayed and inverted waveform (negative-going), available at the TRIG OUT connector on the front panel, for use in triggering an external pulse generator if desired; 3) provides a delayed and inverted step (negative) having a rise time of approximately 50 picoseconds. This fast-rise step may be connected externally from the STEP OUTPUT connector to the SIGNAL IN connector on the front panel.

4-6. MULTIVIBRATOR. Multivibrator Q101/Q102 free-runs at about 150 kc, and produces a square-wave output. Narrow band RF interference is eliminated by adjusting R110 ( $f_c$ ) which varies the sampling repetition rate and its harmonics to avoid the interference band. The positive rise at the collector of Q102 (0 to +15 volts) is taken as the reference time for the fast ramp. This positive rise is also applied to DL101, which delays its appearance at the base of Q124 by about 140 nanoseconds. The purpose of the delay is to allow the fast ramp to begin before the step signal appears at the sampler, thus permitting the pulse rise to be presented on the CRT screen after the start of the trace.

4-7. TUNNEL DIODE TRIGGER. The delayed positive step passes through emitter follower Q124 and turns on trigger amplifier Q125, which produces a negative-going step (0 to -12 volts). This negative step in turn causes tunnel diode CR123 to switch from 0 to -0.5 volts. A second tunnel diode, CR124, located in the output connector, further sharpens the negative step from Q125, resulting in a rise time of approximately 50 picoseconds. STEP STABILITY control R135 sets the operating point for CR124, and Zero Level Adj R154 provides a small positive voltage to set the DC level at J101 exactly to zero before the negative step. Pulse Shape Adj, R172, provides a feedback loop to compensate for droop in the pulse amplitude.

4-8. TUNNEL DIODE RESET. The tunnel diodes are switched back to their initial state by a reset circuit which operates as follows: the positive step which is applied to the base of Q124 is also applied to the base of Q121, an emitter follower, but this step has no effect on the blocking oscillator, Q122; the negative-going step from the multivibrator, (+15 volts to 0), however, triggers the blocking oscillator and turns on reset amplifier Q123. Current from R135 is then drawn away from the tunnel diodes (into Q123), causing the diodes to switch back to their low-voltage state. With the end of the reset pulse, the diodes return to their steady-state operating point as set by R135. The circuit is then ready to generate another output step when the collector of Q102 in the multivibrator again goes positive.

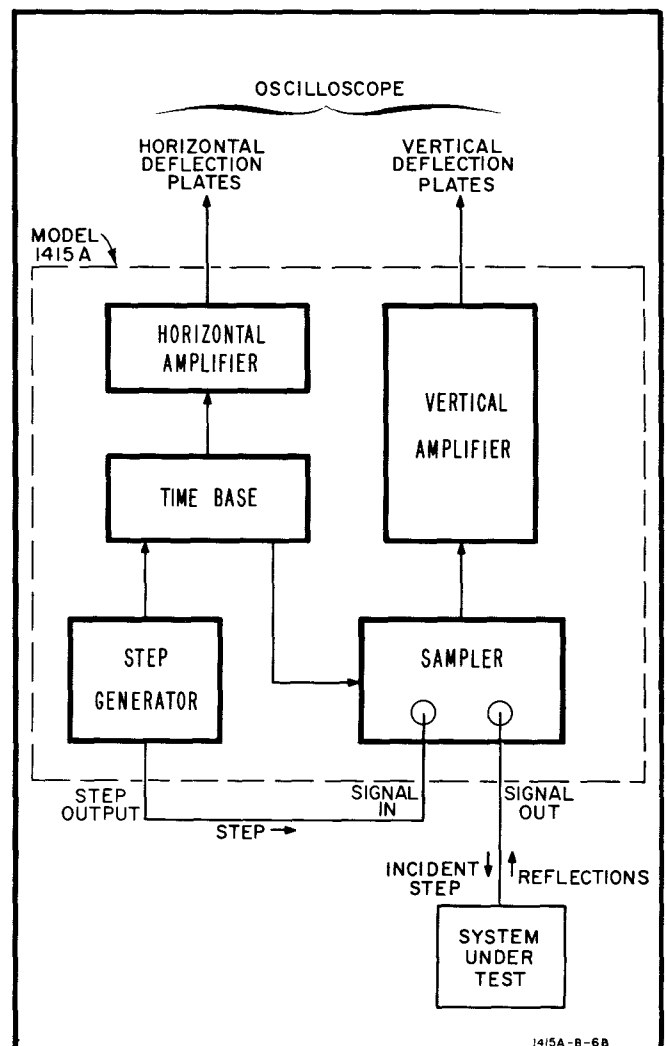
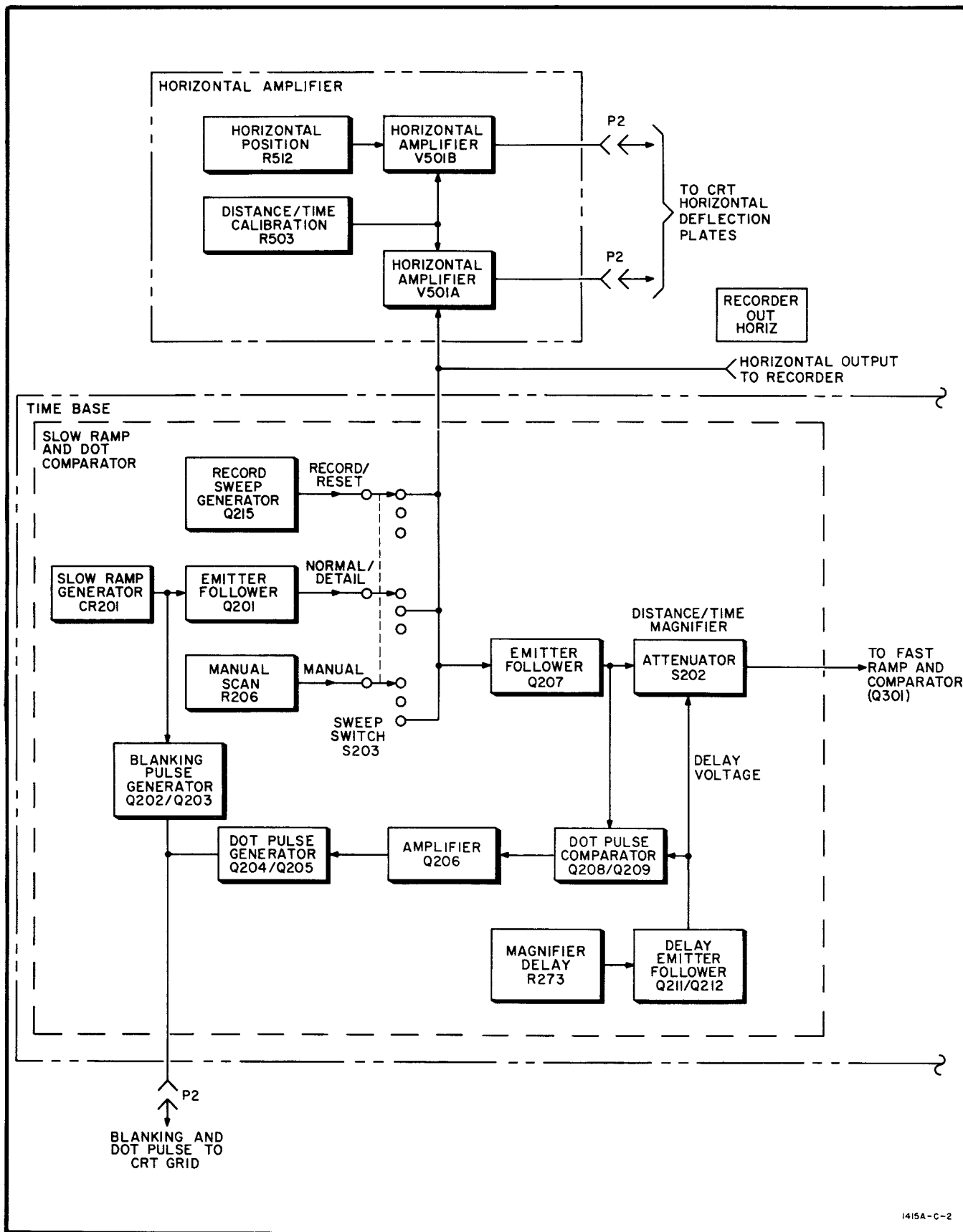

Figure 4-2. Model 1415A Block Diagram



1415A-C-2

Figure 4-3. Horizontal Amplifier, and Slow Ramp and Dot Comparator Block Diagram

**4-9. SLOW RAMP GENERATOR.**

4-10. The slow ramp generator, shown in Figures 4-3 and 5-11, produces the horizontal sweep voltage for the oscilloscope CRT. This voltage is also used for comparison with the fast ramp in time base determination (see Paragraph 4-19). This voltage may be an internally-generated sawtooth (SWEEP control set to NORMAL or DETAIL), a single slow ramp (RECORD), or a varying dc level (MANUAL). The following discussion assumes that the internal scan voltage is being used. Four-layer diode CR201 is used as a sawtooth-generating circuit, which operates at a free-running rate of either 50 cps (NORMAL) or 5 cps (DETAIL). The slower rate (DETAIL) produces more samples per sweep, since coincidence of the comparator will occur ten times as often on one sweep. Sawtooth amplitude at the base of emitter follower Q201 is approximately zero to +20 volts.

4-11. TIME SCALE, RECORD, AND SWEEP. Amplitude of the slow ramp applied to the DISTANCE/TIME MAGNIFIER switch for calibration of the time scale is set by Time Scale Cal adjustment R252. The unattenuated scan voltage is applied to the horizontal amplifier from the junction of R251/R252 to provide horizontal deflection of the CRT. With the SWEEP switch in the MANUAL position, the dc voltage on the wiper of MANUAL SCAN control R206 is the slow ramp signal. In RECORD position, a 60 second ramp signal is generated by R208/C204 for use with an X-Y recorder. This ramp signal is isolated from its load by Q215, and is clamped by CR210 when it reaches +22 volts. In the RESET position, CR210 serves to set the ramp back to approximately zero volts. After the slow ramp has passed through the Time Scale Cal potentiometer it is attenuated by the DISTANCE/TIME MAGNIFIER switch to magnify the time scale from 1 to 200 times in a 1, 2, 5 sequence. Since, in a magnified setting of the time scale, the fast ramp does not have to rise as far to reach coincidence with the attenuated slow ramp, sampling will occur sooner after the reference time (sync pulse) than in an un-magnified setting; this results in a faster time scale. Returning the bottom end of the magnifier attenuator to the emitter of Q211, which provides the source voltage for determining dot position (see Paragraph 4-13), ensures that expansion of the time base will be centered around the point represented by the dot on the CRT screen.

4-12. CRT BLANKING SIGNAL. Blanking pulse generator Q202/Q203 is a monostable multivibrator, producing a negative pulse of about 1.5 milliseconds in length and 20 volts in amplitude to blank the CRT beam during retrace. Q203 is cut off by the negative slope of the slow ramp, which in turn causes Q202 to conduct, thus producing the negative pulse which is applied to the CRT grid for beam blanking.

**4-13. DOT GENERATOR.**

4-14. MAGNIFIER DELAY. Adjustments Max Dot Delay R274 and Min Dot Delay R272 provide calibrated voltage levels for R273, the MAGNIFIER DELAY control. With these adjustments correctly set, the front panel dial for R273 is calibrated in centimeters for accurate time measurements between any points selected on the display. The voltage selected by R273 is

applied to emitter followers Q210 and Q211, which reduce impedance to approximately 2 ohms. The DC output voltage from the emitter of Q211 is applied to the base of Q209, which is normally conducting (slow ramp at zero volts).

4-15. DOT PULSE COMPARATOR. When the slow ramp passes the voltage level at the base (and emitter) of Q209, the dot pulse comparator switches so that Q209 is off and Q208 is on. Tunnel diode CR203, as a result, is also caused to switch, producing a sharp negative step at the base of Q206, going from about +15 volts to +14.5 volts. This step turns on amplifier Q206, producing an amplified positive step which is differentiated by C223 and Q205.

4-16. DOT PULSE GENERATOR. The differentiated positive pulse turns off Q205, which in turn causes Q204 to conduct. The positive pulse at the collector of Q204 is about 25 volts in amplitude, and is terminated after about 15 microseconds when the dot pulse generator, a monostable multivibrator, returns to its quiescent state. The dot pulse comparator, Q208/Q209, returns to its initial state when the negative retrace slope of the slow ramp cuts off Q208. The 15-microsecond positive output pulse is applied through pin 1 of P2 to the grid of the CRT, producing a brightened dot on the CRT trace at the point selected.

**4-17. FAST RAMP GENERATOR.**

4-18. The fast ramp generator, consisting of Q305/Q306 circuits, is shown in Figures 4-1 and 5-14. The ramp comparator, also shown in these figures, is described separately in Paragraph 4-19. The fast ramp waveform is initiated by the positive-going undelayed sync pulse from Q102 (see Paragraph 4-5), which turns off sync emitter follower Q306. The voltage at the cathode of diode CR313 goes positive to +15 volts, and with the anode at zero, the diode is cut off. The conduction current of fast ramp generator Q305, a constant current source, is now into timing capacitors C330 through C334. As the charge builds up on the capacitors switched into the circuit by the front-panel DISTANCE/TIME control, a linear ramp voltage is generated, having a slope dependent upon the value of capacity in the circuit. This ramp is applied to the base of Q303 in the comparator. Stray capacity is taken into account and is brought to a standard value by C330, a variable capacitor. Adjustment is made on the 20 NSEC/CM range, since it is on this range that stray capacity has most effect. The ramp voltage reaches an amplitude of about +15 volts when it is terminated as the negative-going step occurs from Q102 of the multivibrator. This step turns on Q306, lowering the cathode voltage of CR313 to about zero volts. With the anode at about +15 volts, CR313 conducts and provides both a conduction path for Q305 and a discharge path for the timing capacitors; this path is through Q306 to the -12.6 volts supply. A section of the DISTANCE/TIME switch provides a delay voltage of about +1 volt (junction R335/R336) on the three slower TIME scale settings. Thus on these three ranges the base of Q303 is more positive and coincidence of the comparator occurs earlier. This ensures a display of the leading edge of the step output after a convenient interval from the start of the trace. On the fastest DISTANCE/TIME

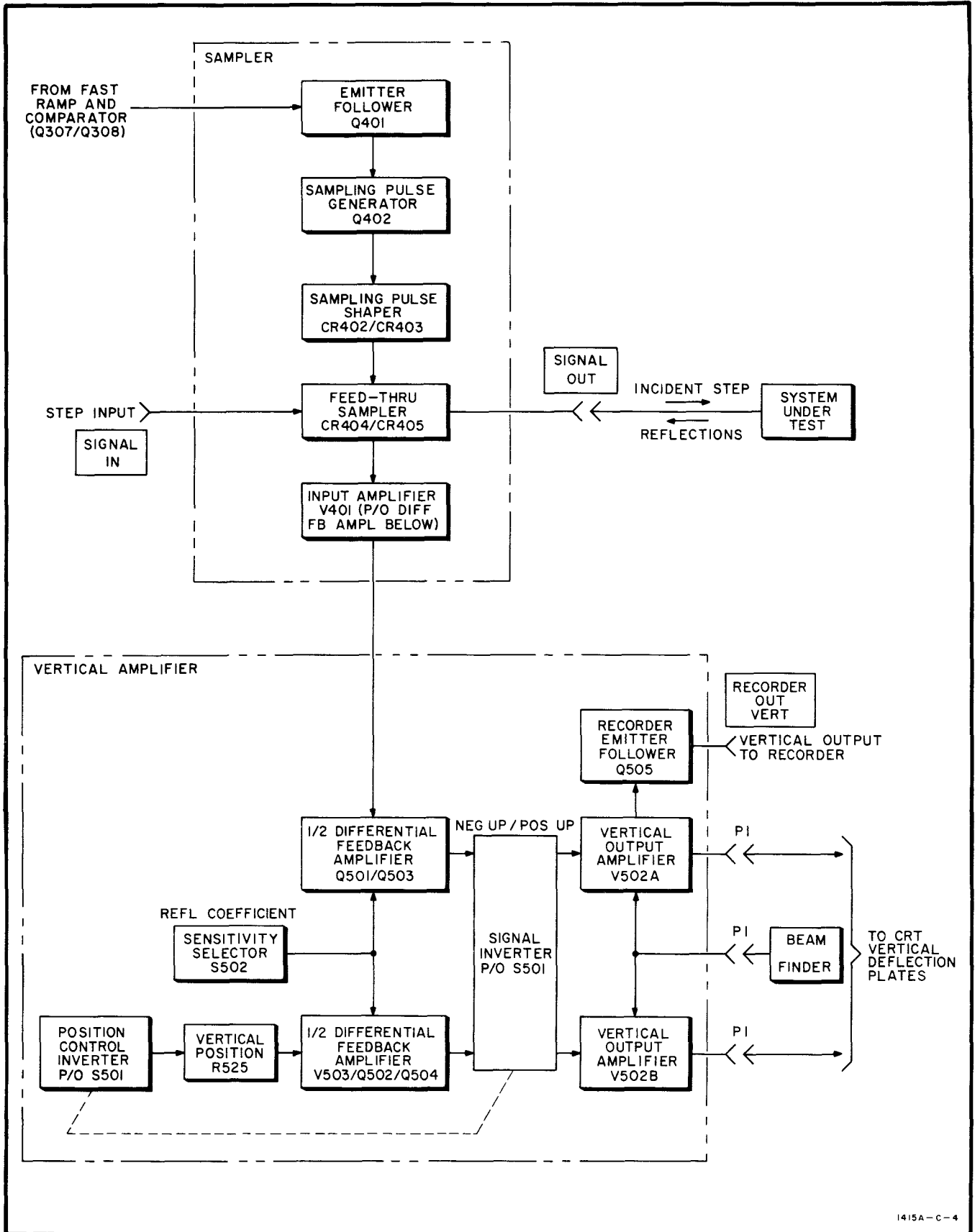

Figure 4-4. Sampler and Vertical Amplifier Block Diagram

setting, this additional delay would place the leading edge too far to the right, and is therefore not used.

#### 4-19. RAMP COMPARATOR.

4-20. The ramp comparator compares the amplitudes of the slow and fast ramps, and when they are the same, produces a trigger pulse which operates the sampler circuit. The slow ramp is applied through emitter follower Q301 to Q302, which is normally conducting through CR301 and R302. When the fast ramp, applied to the base of Q303, passes the instantaneous amplitude of the slow ramp, the comparator switches, with Q302 cut off and Q303 conducting. The resulting negative step at the collector of Q303 causes tunnel diode CR303 to switch also, and the sharp negative step at the base of Q304 (+15 volts to +14.5 volts) turns this transistor on. The inverted (positive) step at the collector of amplifier Q304 is differentiated by C306 and R305 to produce a positive spike which triggers sampler trigger generator Q307/Q308. Negative spikes are removed by CR304. The positive spike cuts off Q307, which turns on Q308, and an output step rising from -12.6 volts to 0 is applied to Q401 in the sampler circuit. This step is the trigger which initiates sampling, and since the slow ramp applied to the comparator is gradually rising in voltage, each output trigger to the sampler will occur slightly later from the reference time (start of the first ramp). Thus, since the signal to be sampled occurs at a fixed, specific time after the reference time, scanning of the signal will begin before the step output appears, and will continue considerably after it appears (depending on DISTANCE/TIME settings). The steeper the slope of the fast ramp (or the lower the slope of the slow ramp), the faster will be the effective time scale; the determining factor is how soon coincidence of the comparator occurs after the reference time.

#### 4-21. SAMPLER.

4-22. The sampler circuit, Figures 4-4 and 5-18, receives positive-going trigger steps from Q308 (negative steps from multivibrator Q307/Q308 have no effect on the following circuitry), each with gradually increasing separation from the reference time. The positive steps are differentiated by C401 and R402 into positive spikes which trigger sampler pulse generator Q402, a blocking oscillator. The blocking oscillator waveform is converted by pulse transformer T401 into balanced voltage spikes: positive at terminal 4 of the transformer, and negative at terminal 3. These spikes apply reverse bias to step-recovery diodes CR402 and CR403 which have an extremely sharp recovery transition characteristic. Diode Bias adjustments R410 and R412 set the forward bias of CR402 and CR403 respectively for optimum pulse shape. The resultant sharp spikes (sampling pulses) are applied through C421 and C422 to forward-bias sampling diodes CR404 and CR405 respectively. Capacitors C421 and C422 almost immediately charge (or discharge) to the level of the input signal at that instant, and after the very short sampling pulse ends, the charge on these capacitors leaks through R422

and R423 to charge the input capacity of V401. As the input signal is gradually scanned, the voltage on this capacity will vary accordingly and will be amplified by the vertical amplifier for display on the CRT screen.

#### 4-23. VERTICAL AMPLIFIER.

4-24. The vertical amplifier, Figures 4-4 and 5-23, amplifies the input signal appearing at the grid of V401 in the sampler circuit. The first three stages comprise a differential feedback amplifier which has a gain inversely proportional to the value of feedback resistance inserted by SENSITIVITY switch S502. Zero Set adjustment R527 sets the voltage at the grid of V503 to be zero with the VERTICAL POSITION control centered, so that switching of the Neg Up/Pos Up control will not cause a vertical shift of the trace. The vertical signal may be inverted by switching S501 to Neg Up, which reverses the differential signal applied to the grids of V502A/B. Calibration of the vertical amplifier is accomplished by adjusting STEP CAL R574, which shunts part of the signal at the input of V502, and variable VERNIER control R575 which adjusts the degree of degeneration in the output stage. Broad band interference is eliminated, or attenuated in the case of a high amplitude interference, by adjusting R598A/B (BW) which reduces the bandwidth of the vertical amplifier, thereby rejecting more of the interference band. Differential output signal is applied through pins 12 and 24 of P1 to the CRT vertical deflection plates in the oscilloscope. A single-ended output is taken from the plate of V502A and passed through Q505 to be made available at the front-panel RECORDER OUT connector. The BEAM FINDER switch (located on the oscilloscope front panel), when pressed, allows R587 to be inserted in series with the V502 cathode supply. This greatly reduces the tube current and stage gain, so that an off-screen beam will be brought into view. Required adjustment of appropriate amplifier controls will then keep the trace on-screen when the button is released.

#### 4-25. HORIZONTAL AMPLIFIER.

4-26. The horizontal amplifier, Figures 4-3 and 5-22, receives the horizontal scan voltage, either the slow ramp or a manually determined voltage, amplifies this voltage, and applies it differentially to the horizontal deflection plates of the CRT. DIST/TIME CAL adjustment R503 controls the degree of degeneration in the amplifier, and HORIZ POS control R512 adjusts the DC level of the plates of V501A/B. The BEAM FINDER operates in the same way as in the vertical amplifier, described in Paragraph 4-24.

#### 4-27. POWER SUPPLY.

4-28. Supply voltages of +250 volts, +100 volts, -100 volts, and -12.6 volts are supplied by the oscilloscope for operating most of the circuits in the Model 1415A. Two additional supply voltages are derived from the +100 volts supply, as shown in Figure 5-24. Two 15-volt avalanche diodes, CR601 and CR602 are connected in series to provide a voltage of +30 volts, and an amplifier/emitter-follower circuit, Q601 and Q602, provides an output of +15 volts.

Table 5-1. Equipment Required for Tests and Adjustments

Instrument	Recommended Model	Required Characteristics	Required for	Ref Para
1. Voltmeter Calibrator	hp 738AR	DC output: 10 mv to 1 volt, $\pm 0.3\%$	Refl Coefficient Attenuator Check	5-10
2. Short Circuit Termination	General Radio 874-WN		Rise Time Check	5-12
3. Impedance Bridge	General Radio 1650A	To measure resistance of 50 ohms, accuracy $\pm 0.5\%$	Output Impedance Check	5-16
4. Transmission Line	Any polyethylene 50-ohm coaxial line, 100 cm long		Distance/Time Scale Check	5-11
5. Coaxial Load	hp 908A, or General Radio 874-W50	50 ohms, $\pm 1\%$	Performance Check and Adjustments	
6. DC Voltmeter	hp 410B/C	0 to +30 volts, accuracy $\pm 3\%$	Power Supply Adjustments	5-24
7. High Frequency Oscilloscope	hp 175A with 1750A plug-in	0.5 v/cm sensitivity, rise time 15 nsec	Troubleshooting	5-43, 5-45
8. L-C Meter	Tektronix Type 130	To indicate 82 pf	20-nsec Time Scale Adjustment	5-32

## SECTION V MAINTENANCE

### 5-1. INTRODUCTION.

5-2. This section covers maintenance, troubleshooting, and adjustment of the Model 1415A Time Domain Reflectometer. A performance check is included which may be used as incoming inspection or after adjustments have been made to verify that the instrument meets its specifications.

### 5-3. PERFORMANCE CHECK.

5-4. The performance check is intended to determine whether or not the instrument is operating within its specifications. If adjustment is necessary, refer to Paragraph 5-18.

### 5-5. TEST EQUIPMENT.

5-6. Test equipment recommended for the performance check is listed in Table 5-1, items 1 through 7. Similar instruments having the listed characteristics may be substituted.

### 5-7. PROCEDURE.

5-8. Install the  $f_p$  Model 1415A Time Domain Reflectometer in the dual plug-in compartment of the Oscilloscope, which requires the removal of the plug-in divider. The Neg Up/Pos Up switch located on the bottom of the Model 1415A should normally be set to Neg Up.

### 5-9. FRONT PANEL PRELIMINARY SETTINGS.

CM LINE CM DISPLAY . . . . . Fully CCW  
 DISTANCE/TIME MAGNIFIER . . . . . 1  
 VERNIER . . . . . CAL  
 SWEEP . . . . . NORMAL

### 5-10. REFL COEFFICIENT ATTENUATOR.

- a. Connect Voltmeter Calibrator to SIGNAL IN.
- b. Set Model 1415A controls:
  - NSEC/CM . . . . . 100
  - MAGNIFIER . . . . . 50
  - REFL COEFFICIENT . . . . . 0.1
- c. Set Voltmeter Calibrator:
  - OUTPUT SELECTOR . . . . . OFF
  - MULTIPLIER . . . . . 0.1
  - RANGE . . . . . 2
  - FUNCTION . . . . . CALIBRATE
- d. Adjust VERT POSITION to place sweep on top CRT graticule line.
- e. Adjust STEP CAL to obtain exactly 10 cm deflection (top to bottom graticule line) when Voltmeter

Calibrator OUTPUT SELECTOR is switched from OFF to DC+.

f. Check all other ranges, referring to Table 5-2 for settings. Position trace on top graticule line with Voltmeter Calibrator OFF; deflection when switched to DC+ should be as indicated in the table.

Table 5-2. Vertical Magnifier Check

Refl Coefficient	Voltmeter Calibrator		CM of Deflection
	Multiplier	Range	
.005	.01	1	10 ± .3
.01	.01	2	10 ± .3
.02	.1	.3	7.5 ± .2
.05	.1	1	10 ± .3
.1	.1	2	10
.2	1	.3	7.5 ± .2
.5	1	1	10 ± .3

g. Disconnect Voltmeter Calibrator, and connect STEP OUTPUT to SIGNAL IN using EL connectors.

h. Return REFL COEFFICIENT to .1 and adjust STEP CAL for 10 cm deflection.

### 5-11. DISTANCE/TIME SCALE.

- a. Adjust DIST/TIME CAL as shown in Figure 3-4.
- b. Using available 50 ohm polyethylene transmission line with GR connector on one end, cut for exactly 100 cm length including connector.
- c. Connect transmission line to SIGNAL OUT, and connect STEP OUTPUT to SIGNAL IN with the two supplied EL connectors.
- d. Set:
  - REFL COEFFICIENT . . . . . 0.2
  - CM LINE/CM DISPLAY . . . . . 200
  - DISTANCE/TIME MAGNIFIER . . . . . 20
- e. Center step trace and resulting line reflection on CRT with VERT POSITION and MAGNIFIER DELAY.
- f. Step and line reflection should be displayed 10 cm ± 0.5 cm apart.
- g. Check other DISTANCE/TIME ranges in the same manner (steps d, e, and f), using these settings given in Table 5-3. Horizontal deflection in each case should be as indicated.
- h. Disconnect transmission line from SIGNAL OUT.

Table 5-3. Distance Time Scale Check

CM LINE / CM DISPLAY (Polyethylene)	Magnifier	Horizontal Deflection
200	20	10 cm $\pm$ .5 cm
500	50	10 cm $\pm$ .5 cm
1000	100	10 cm $\pm$ .5 cm
2000	200	10 cm $\pm$ .5 cm

**5-12. RISE TIME, JITTER, AND INTERNAL REFLECTIONS.**

- a. Connect Short Circuit Termination to SIGNAL OUT.
- b. Connect STEP OUTPUT to SIGNAL IN with the two EL connectors.
- c. Set:
  - NSEC/CM . . . . . 20
  - MAGNIFIER . . . . . 200
  - REFL COEFFICIENT . . . . . 0.1
- d. Locate negative step with MAGNIFIER DELAY.
- e. Set VERNIER for 10 cm of fast negative transition.
- f. Rise time of this transition should be less than 0.15 nsec (1.5 cm) from the 90% to 10% points.
- g. Horizontal jitter on either the positive or negative step should be less than 20 picoseconds (0.2 cm).
- h. Disconnect Short Circuit Termination.
- i. Connect short length (longer than one foot) of 50 ohm cable to SIGNAL OUT.
- j. Connect Short Circuit Termination to end of 50 ohm cable.
- k. Set VERNIER to CAL.
- m. Reflections on the trace after the negative step should be less than 1.0 cm.

**5-13. OVERSHOOT AND RINGING.**

- a. Disconnect shorted cable from SIGNAL OUT.
- b. Connect 50 ohm coaxial load to SIGNAL OUT.
- c. Set:
  - REFL COEFFICIENT . . . . . 0.01
  - NSEC/CM . . . . . 20
  - MAGNIFIER . . . . . 200
- d. Locate positive steps with MAGNIFIER DELAY.
- e. Overshoot on the leading edge should be less than 5 cm.
- f. Set DISTANCE/TIME MAGNIFIER to 50.
- g. Ringing on pulse top should be less than 0.5 cm (vertically) after first 5 cm of the step.

**5-14. DROOP.**

- a. Set:
  - NSEC CM . . . . . 200
  - DISTANCE/TIME MAGNIFIER . . . . . 1
  - SWEEP . . . . . DETAIL
  - REFL COEFFICIENT . . . . . 0.01
- b. Droop on pulse should be less than 1 cm.
- c. Return SWEEP to NORMAL.

**5-15. NOISE AND INTERNAL PICKUP.**

- a. Connect 50-ohm coaxial load to SIGNAL OUT.
- b. Remove EL connectors from Model 1415A.
- c. Set:
  - NSEC/CM . . . . . 200
  - DISTANCE TIME MAGNIFIER . . . . . 1
  - REFL COEFFICIENT . . . . . .005
- d. Noise and internal pickup on base line should be less than 0.2 cm peak

**5-16. OUTPUT IMPEDANCE.**

- a. Measure the output resistance of the STEP OUTPUT with the Impedance Bridge.
- b. Resistance should be 50 ohms  $\pm$  1 ohm.

**5-17. DYNAMIC RANGE.**

- a. Connect STEP OUTPUT to SIGNAL IN with the two EL connectors.
- b. Connect 50 ohm coaxial load to SIGNAL OUT connector.
- c. Set REFL COEFFICIENT to .1, and adjust STEP CAL for 10 cm step.
- d. Remove 50 ohm load and set.
  - REFL COEFFICIENT . . . . . 2
  - NSEC/CM . . . . . 20
  - DISTANCE TIME MAGNIFIER . . . . . 50
- e. Display should be approximately as follows:

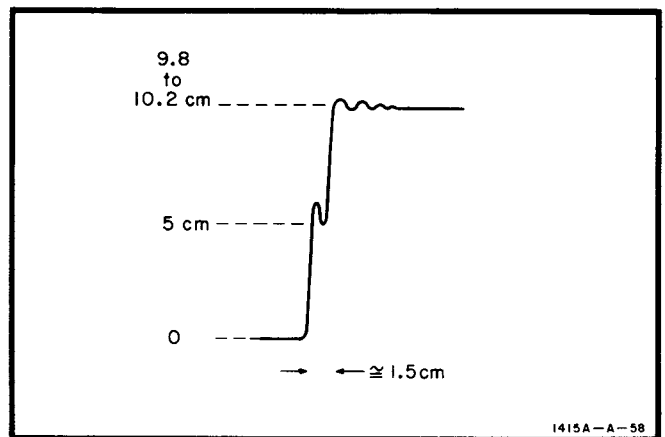

**5-18. ADJUSTMENTS.**

5-19. Adjustment procedures for the Model 1415A are given in Paragraphs 5-24 through 5-38.

5-20. REQUIRED TEST EQUIPMENT. Test equipment recommended for the adjustment procedure is listed in Table 5-1, items 6 through 10. Similar instruments having the listed characteristics may be substituted.

5-21. LOCATION OF ADJUSTMENTS. Figure 5-1 shows the location of all internal adjustments in the Model 1415A.

**5-22. PROCEDURE.**

5-23. Install the Model 1415A in the Oscilloscope. Turn on the instrument and allow several minutes of warm-up.

**5-24. POWER SUPPLY ADJUSTMENT.**

a. Connect DC Voltmeter to white-brn-red lead on power supply board (mounted on rear panel).

b. Adjust +15V Adj R602 on power supply board to obtain +15 volts.

c. Measure voltage at junction of R606, CR601 with DC Voltmeter. Voltage should be  $-30 \text{ volts} \pm 3 \text{ volts}$ .

**5-25. STEP STABILITY ADJUSTMENT.**

a. Set:

CM LINE/CM DISPLAY . . . . . full CW  
 DISTANCE/TIME MAGNIFIER . . . . . 50  
 REFL COEFFICIENT . . . . . 0.2  
 SWEEP . . . . . NORMAL  
 STEP STABILITY . . . . . Midrange

b. Connect STEP OUTPUT to SIGNAL IN with two 874-EL connectors (supplied), and connect a 50-ohm coaxial load to SIGNAL OUT.

c. Center step on CRT with MAGNIFIER DELAY and VERT POSITION.

d. Set REFL COEFFICIENT to .02 keeping lower corner of step centered on CRT.

e. Adjust STEP STABILITY for sharpest corner without losing stability of the trace. Trace should still remain stable when MAGNIFIER is set to 200.

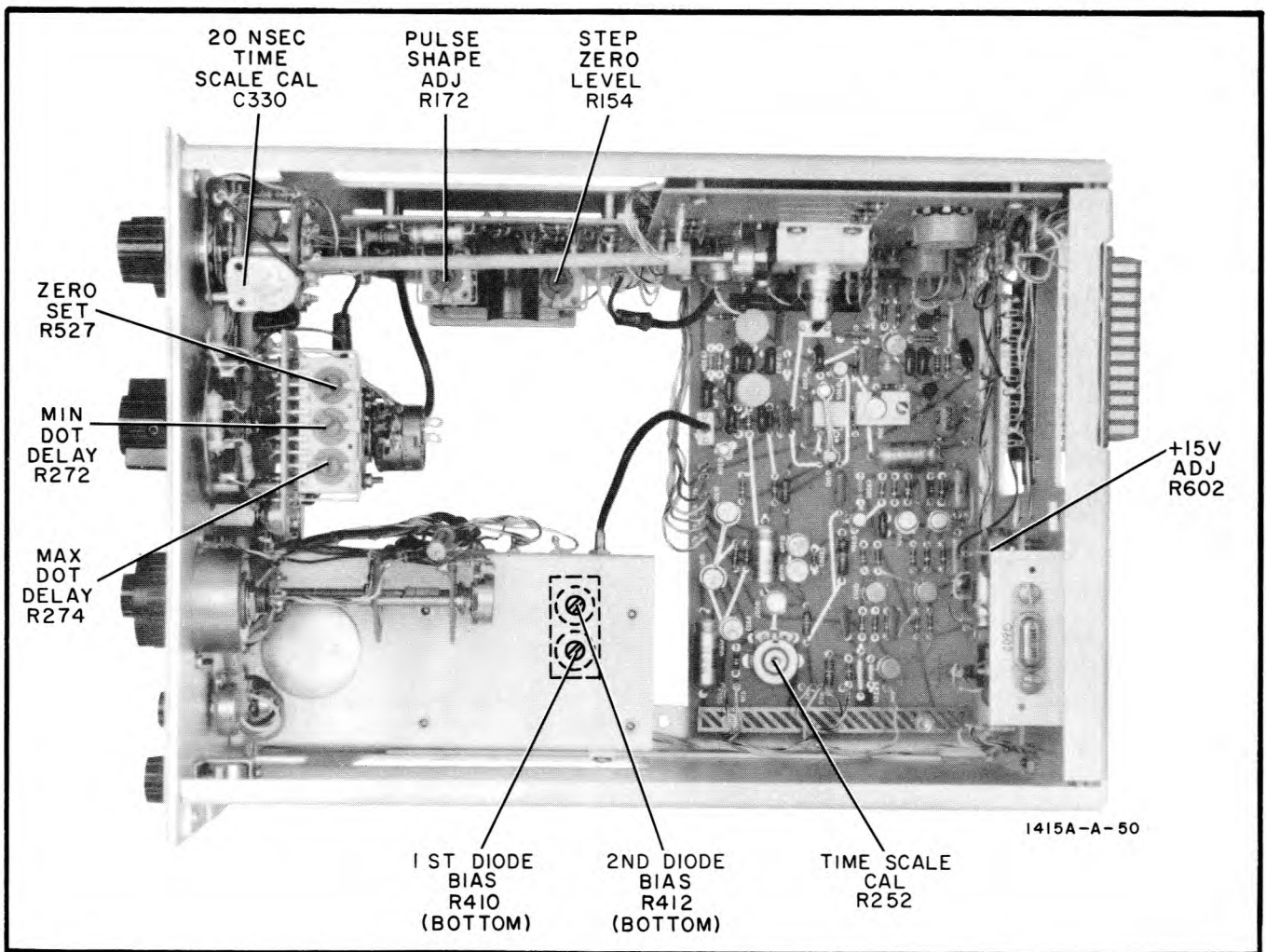

Figure 5-1. Location of Adjustments

**5-26. STEP ZERO LEVEL ADJUSTMENT.**

- a. Set:
  - DISTANCE/TIME MAGNIFIER . . . . . 50
  - MAGNIFIER DELAY . . . . . 0.00

b. Adjust Step Zero Level R154 to eliminate DC shift of base line when 50-ohm load is connected to and disconnected from the SIGNAL OUT connector.

**5-27. SAMPLER DIODE BIAS ADJUSTMENT.**

a. Set up 1415A functions as described in Paragraph 5-17.

b. Adjust 1st and 2nd Diode Bias, R410 and R412 (located on bottom of sampler can), for display as shown in Paragraph 5-17.

**5-28. STEP CAL ADJUSTMENT.**

a. Connect a 50-ohm load on short length of 50-ohm cable to SIGNAL OUT.

- b. Set:
  - CM LINE/CM DISPLAY . . . . . full cw
  - DISTANCE/TIME MAGNIFIER . . . . . 1
  - REFL COEFFICIENT . . . . . 0.1
  - REFL COEFFICIENT VERNIER . . . . . CAL

c. Adjust STEP CAL for 10 cm deflection.

**NOTE**

Time scale adjustments given in Paragraphs 5-29 through 5-36 should be made in order.

**5-29. DIST/TIME CAL ADJUSTMENT.**

5-30. Set DIST/TIME CAL for 11cm of sweep.

**5-31. TIME SCALE CAL AND 20-NSEC TIME SCALE CAL ADJUSTMENTS.**

**5-32. COARSE 20-NSEC TIME SCALE CAL ADJUSTMENT.**

- a. Turn off power and remove Model 1415A from Oscilloscope.
- b. Set NSEC/CM to a position halfway between 20 and 50.

c. Connect LC Meter to 20 NSEC Time Scale Cal C330 at end nearest front panel.

d. Adjust C330 for 82 pf on the LC Meter.

e. Disconnect LC Meter, replace Model 1415A in Oscilloscope and turn on power.

5-33. The two time scale adjustments can be made by either of the following methods.

**5-34. METHOD ONE.**

- a. Cut a section of 50-ohm transmission line (use

cable with solid polyethylene dielectric, such as RG58) to exactly 100 cm length, including a connector at one end.

b. Connect another 50-ohm cable (with connectors on both ends) of at least 2 meters in length to the SIGNAL OUT connector. Connect STEP OUTPUT to SIGNAL IN using the two 874-EL connectors.

- c. Set:
  - REFL COEFFICIENT . . . . . 0.2
  - CM LINE/CM DISPLAY . . . . . 2000
  - DISTANCE/TIME MAGNIFIER . . . . . 200

d. Set the 50% point of the resulting open circuit reflection to the 0.0 cm point on the left side of the graticule.

e. Adjust Time Scale Cal R252 so that open circuit reflection moves exactly 10 cm when calibrated cable (step a) is connected and disconnected from the open end of cable connected to SIGNAL OUT connector.

- f. Set:
  - CM LINE/CM DISPLAY . . . . . 200
  - MAGNIFIER . . . . . 20

g. Repeat step e, except that C330 is adjusted instead of R252.

**5-35. METHOD TWO.**

a. Use any available 50-ohm transmission line or cable of solid polyethylene dielectric type with a length of 50 cm to 200 cm as the calibrating cable. Measure its length in cm exactly.

b. Perform steps b through g of Method one, above, changing the MAGNIFIER setting as required. Adjust R252 and C330 in steps e and g to provide correct length readings.

**5-36. DOT DELAY ADJUSTMENTS.**

a. Remove the connection between STEP OUTPUT and SIGNAL IN.

- b. Set:
  - HORIZ POSITION . . . . . to center trace
  - VERT POSITION . . . . . to center trace
  - MAGNIFIER DELAY . . . . . 0.00

c. Adjust Min Dot Delay R272 to position intensified dot on left graticule line.

d. Set MAGNIFIER DELAY to 10.00.

e. Adjust Max Dot Delay R274 to position intensified dot on left graticule line.

f. Repeat steps b through e until intensified dot lines up with both graticule lines without readjustment.

**5-37. ZERO SET ADJUSTMENT.**

- a. Center trace with VERT POSITION.
- b. Adjust Zero Set R527 to obtain no trace shift when the Pos Up/Neg Up switch S502 is alternately switched from one position to the other.

**5-38. PULSE SHAPE ADJUSTMENT.**

- a. Set:
  - REFL COEFFICIENT . . . . . 0.01
  - NSEC/CM . . . . . 200
  - MAGNIFIER . . . . . 1
  - SWEEP . . . . . DETAIL
- b. Connect STEP OUTPUT to SIGNAL IN, and place a 50-ohm load on SIGNAL OUT connector.
- c. Locate top of pulse on CRT, and adjust Pulse Shape Adj R172 for flat top on pulse.

**5-39. TROUBLESHOOTING.**

5-40. Figures 5-2 through 5-26 provide typical waveforms, component locations, and schematic diagrams for the Model 1415A. Nominal dc voltages and waveform test points are provided on each schematic as a troubleshooting aid. Waveform and component location figures are located on the page facing each schematic. Conditions for measurement of dc voltages and waveforms are given in Table 5-5, and schematic notes are listed in Table 5-6.

**Note**

Numbers silkscreened on the etched circuit boards beside wire connections are to identify wire colors according to the resistor color coding system; i.e. black = 0, brown = 1, red = 2, etc. For example, the number beside a WHT-RED-BLU wire would be 926.

5-41. Localization of instrument malfunctions can be accomplished in most cases by checking waveforms starting at test point 1 or 6, and then continuing in sequence until a major difference occurs. Once the malfunction area is located, the faulty component(s) may be located by checking the dc voltages and/or visual inspection. The following paragraphs outline procedures and methods of troubleshooting specific areas and/or types of malfunctions. Be sure that the trouble is not due to an incorrect adjustment setting, but do not make arbitrary adjustments in an attempt to eliminate the trouble; refer to Paragraph 5-18 for correct adjustment procedures.

**5-42. GENERAL TROUBLESHOOTING.**

**5-43. BASELINE PRESENT BUT NO PULSE.**

- a. Observe STEP OUTPUT waveform with test oscilloscope (refer to Table 5-1, item 9). The output pulse should have approximately 0.5 volts amplitude at approximately 150 kc repetition rate.
- b. If correct pulse appears, and its duty cycle can be changed by varying the STEP STABILITY control, it may generally be assumed that the pulse generator is functioning correctly. Check connections from STEP OUTPUT jack through SIGNAL IN jack.

c. If the pulse is not present or is not as described in step a, the step generator is at fault. Check test-points 1 through 5, and dc voltages as necessary to locate the faulty component(s).

5-44. NATURE OF JITTER. Nature of the jitter, i.e. 60 cps, random, etc, can be determined by locating the leading edge of the pulse at the center (approximately) of the screen, using a time scale setting so that the jitter is approximately 0.4 cm horizontally. Set SWEEP switch to MANUAL and adjust MANUAL SCAN control so that the dot is at the point of maximum jitter; this will appear on the screen as a vertical "smear." Monitor the signal at either plate of V502 with the test oscilloscope. The period of this waveform will be identical to the period of the jitter, and its amplitude will be proportional to the magnitude of the jitter.

**5-45. JITTER SOURCE.**

- a. Locate the leading edge of the pulse at the center (approximately) of the screen, and note the magnitude of the jitter on any convenient time scale.
- b. Obtain the same nsec/cm as in step a by using a different combination of NSEC/CM and MAGNIFIER control settings.
- c. If the apparent jitter is of the same magnitude as before, the jitter is coming from either the step generator or sampler circuits. Troubleshoot the step generator circuit using test points 1 through 5, and the sampler circuit using test points 18 through 20.

d. If the magnitude of the apparent jitter changes, the jitter is coming from the slow ramp, fast ramp, or comparator circuits. Troubleshoot these circuits using test points 6 through 8, and 12 through 15.

5-46. TIME SCALE NON-LINEARITIES. If the non-linearity at any given point on the waveform varies as the dot is moved across the screen with the MAGNIFIER DELAY control, the slow ramp circuit is at fault (check test points 6 through 8). If the non-linearity does not vary, the trouble is in the fast ramp circuit (check test points 12 through 14).

**5-47. VERTICAL AMPLIFIER TROUBLESHOOTING.**

a. Unbalance. In order to troubleshoot for unbalance, the two sides of the vertical amplifier must be isolated from each other, due to the presence and effect of the feedback circuits.

- (1) Set the REFL COEFFICIENT control to a position between any two ranges.
- (2) Ground the grids of both V401 and V503.
- (3) Check the dc voltages throughout the entire amplifier; these should now be approximately equal to those given on the amplifier schematic (Figure 5-23). The malfunctioning side of the amplifier will be indicated by improper dc voltage readings.

b. Gain. If the overall gain of the amplifier cannot be set properly with the STEP CAL control, the problem is likely due to V502. If gain is in error on any one attenuator setting, check the value of the feedback resistor associated with that setting. The high or low voltage supply in the oscilloscope may also be the cause for low deflection sensitivity.

#### 5-48. HORIZONTAL AMPLIFIER TROUBLESHOOTING.

If the horizontal gain is insufficient to produce a sweep trace of 11 cm, check the waveform voltages at test point 7 (shown in Figure 5-11). If the waveform voltages are correct, replace V501. If the waveform amplitude is low, check test point 6 and the dc voltages in the slow ramp generator circuit to isolate the malfunction.

#### 5-49. DOT COMPARATOR TROUBLESHOOTING.

a. If the bright dot is not present on the CRT display, check test points 9 and 10.

(1) If waveform at test point 9 is incorrect, cause of the malfunction is probably CR203 or Q206.

(2) If waveform at test point 9 is correct and waveform at test point 10 is incorrect, the malfunction is in the dot pulse generator circuit and can be isolated by checking the dc voltages in that circuit.

b. If the bright dot is present on the CRT display but does not move when the MAGNIFIER DELAY control is varied, the probable cause will be Q210 and Q211.

#### 5-50. SPECIFIC TROUBLESHOOTING.

5-51. Table 5-4 lists symptoms and probable causes of malfunctions that may not be isolated when using the general troubleshooting procedures listed above. When using Table 5-4, check first to see if more than one symptom applies. If more than one symptom does apply, check the probable cause column for components common to all symptoms.

#### 5-52. COMPONENT LOCATION.

5-53. Major components on the etched circuit boards are identified by silkscreened reference designations. To supplement this, figures are included in this manual (on pages opposite the schematics) to help locate components which are not silkscreened or where silkscreening is difficult to see. Switch components are also identified in the figures. Refer to the List of Illustrations at the front of this manual for page references to these component location figures.

#### 5-54. SERVICING ETCHED CIRCUIT BOARDS.

5-55. Etched circuit boards used in the Model 1415A have components on one side of the board with a plated conductive layer of metal through component holes.  Service Note M-20D contains useful information on etched circuit repair. The important steps and considerations are:

a. Use a low heat (37 to 47.5 watts, less than 800° F idling temperature), slightly bent chisel tip (1/16 to 1/8 inch diameter) soldering iron, and a small diameter, high tin content solder. If a rosin solder is used, clean the area thoroughly after soldering.

b. Components may be removed by placing the soldering iron on the component lead on either side of the board, and pulling up on the lead. If heat is applied to the component side of the board, greater care is required to avoid damage to the component (especially true for diodes). If heat damage can occur, grip the lead with a pair of pliers to provide a heat sink between the soldering iron and component.

c. If a component is obviously damaged or faulty, clip the leads close to the component and then unsolder the leads from the board.

d. Large components such as potentiometers and tube sockets may be removed by rotating the soldering iron from lead to lead and applying steady pressure to lift the part free (the alternative is to clip the leads of a damaged part).

e. Since the conductor part of the etched circuit board is a metal plated surface, covered with solder, use care to avoid overheating and lifting the conductor from the board. A conductor may be cemented back in place with a quick-drying acetate base cement (use sparingly) having good insulating properties. Another method for repair is to solder a section of good conducting wire along the damaged area.

f. Clear the solder from the circuit board hole before inserting a new component lead. Heat the solder in the hole, remove the iron, and quickly insert a pointed non-metallic object, such as a toothpick.

g. Shape the new component leads and clip to proper length. Insert the leads in the holes and apply heat and solder, preferably on the conductor side.

Table 5-4. Specific Troubleshooting

SYMPTOM	PROBABLE CAUSE	SYMPTOM	PROBABLE CAUSE
1. Stable step cannot be set	C121 faulty CR121 shorted CR123 open CR125 open Q121 shorted b-e Q124 shorted b-e R135 noisy	13. Display leading edge not visible at slower sweep speeds	CR301 shorted
2. Pulse shape poor	CR123 open L150 or R152 leads too long	14. Excess horizontal drift of pulse position	CR303 open
3. Stability set on 20 nsec/cm, not correct on 200 nsec/cm	CR125 open Q121 shorted b-e Q124 shorted b-e	15. Multiple sampling or insufficient dynamic range	CR401 shorted CR403 open CR404 shorted CR405 shorted A3 not grounded tightly "Spades" in sampler block not making proper contact with diode holders A4 shorted
4. Step stability control has no effect	CR121 shorted	16. Excessive smoothing	CR404 open CR405 open
5. Pulse leading edge has excessive delay	Q103 shorted b-e Q305 shorted e-c	17. Noisy baseline	CR404 noisy CR405 noisy
6. Pulse rise time slow	C124 faulty CR124 too slow CR404 too slow CR405 too slow	18. Excessive overshoot or undershoot	R162 too much shunt capacity R441 wrong value, or too much shunt capacity
7. Intermittent horizontal shift in pulse position	A2 or A3 not grounded tightly	19. Excessive jitter	C321 faulty C324 faulty CR123 shorted CR302 shorted CR303 open 140A power supplies defective
8. Excessive internal reflections	CR124 or "fuzz button" seated incorrectly Excess capacity in CR404 or CR405	20. Baseline shifts excessively when connectors are flexed	"Spades" in sampler block not making proper contact with diode holders
9. Microphonics	Intermittent mating of inner conductors in pulse generator housing "Spades" in sampler block not making proper contact with diode holders	21. Excessive vertical drift at turn-on	V401 has grid leakage
10. DETAIL or NORMAL scan does not sweep properly	CR201 leaky Q201 shorted b-e	22. Time base nonlinearities	Q103 shorted b-e
11. Time scale out of calibration for higher magnifications	Q210 shorted b-e Q211 shorted b-e	23. Step slopes off approx 50% on slowest sweep combination	CR124 needs to be rotated 180°
12. No bright dot	CR203 open		

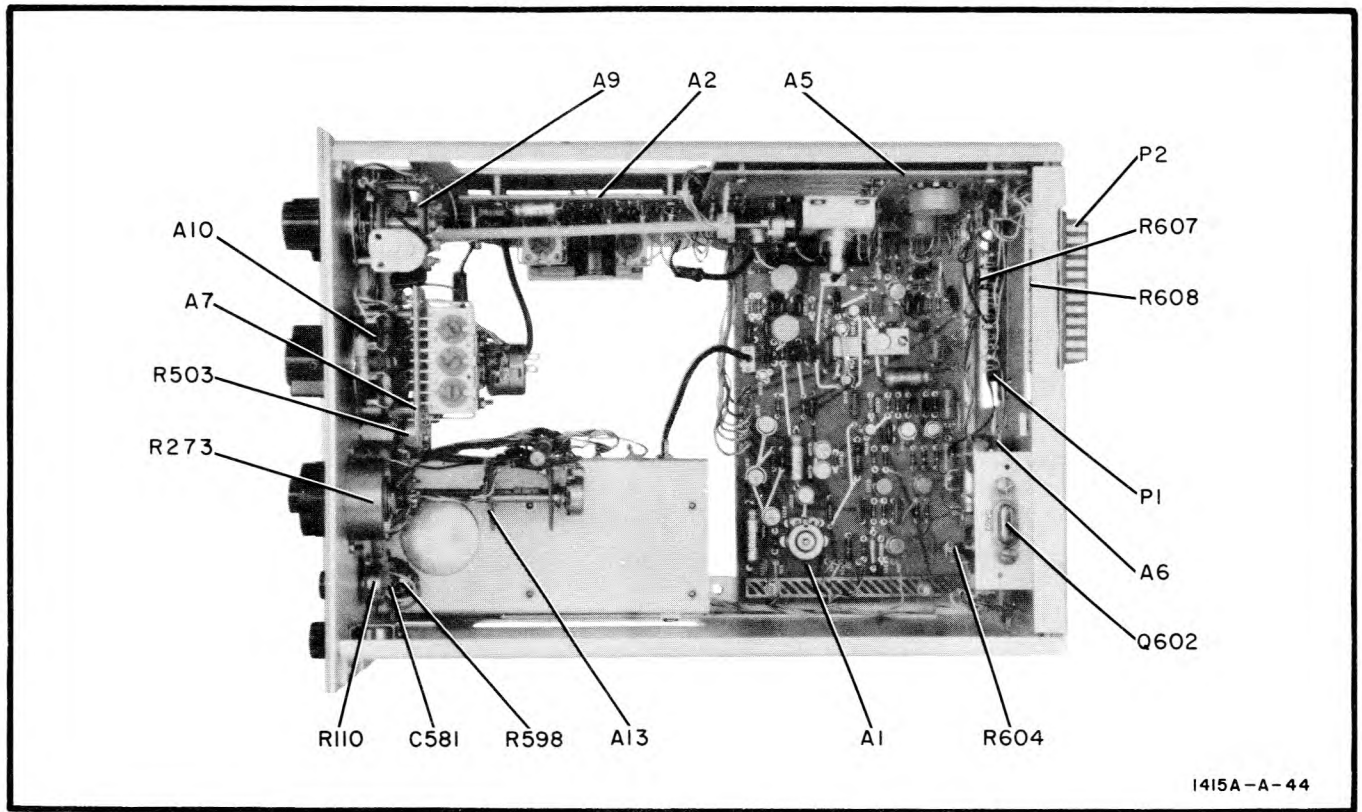

Figure 5-2. Model 1415A Component Location, Top View

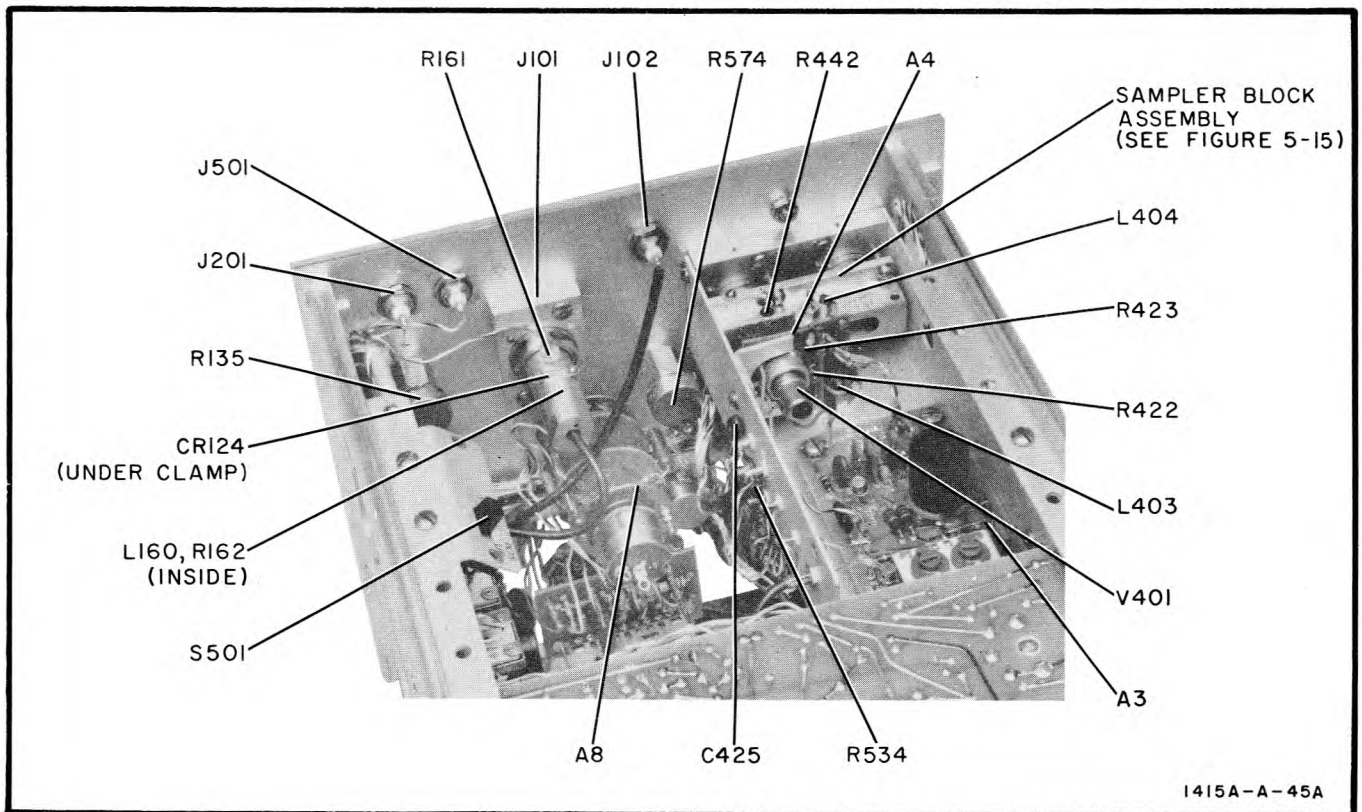

Figure 5-3. Model 1415A Component Location, Bottom View

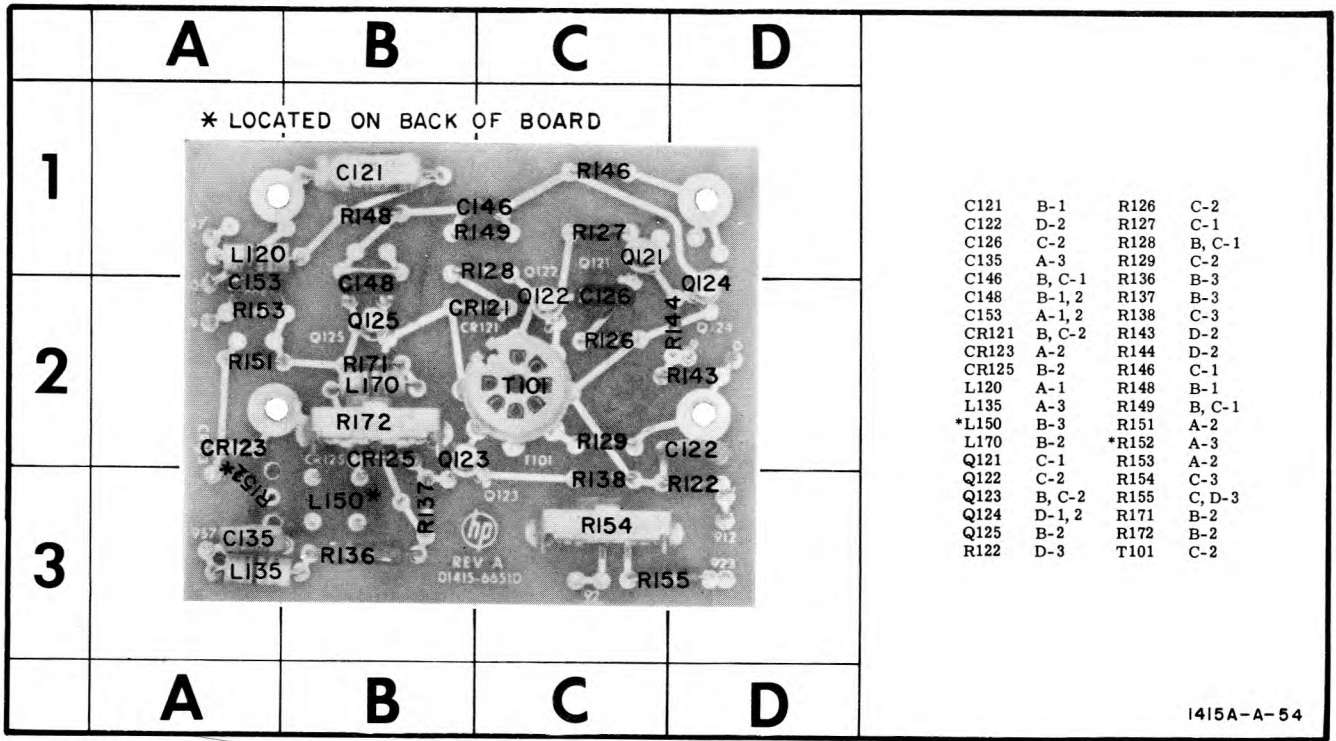

Figure 5-4. Component Locations on A2, Pulse Generator Board

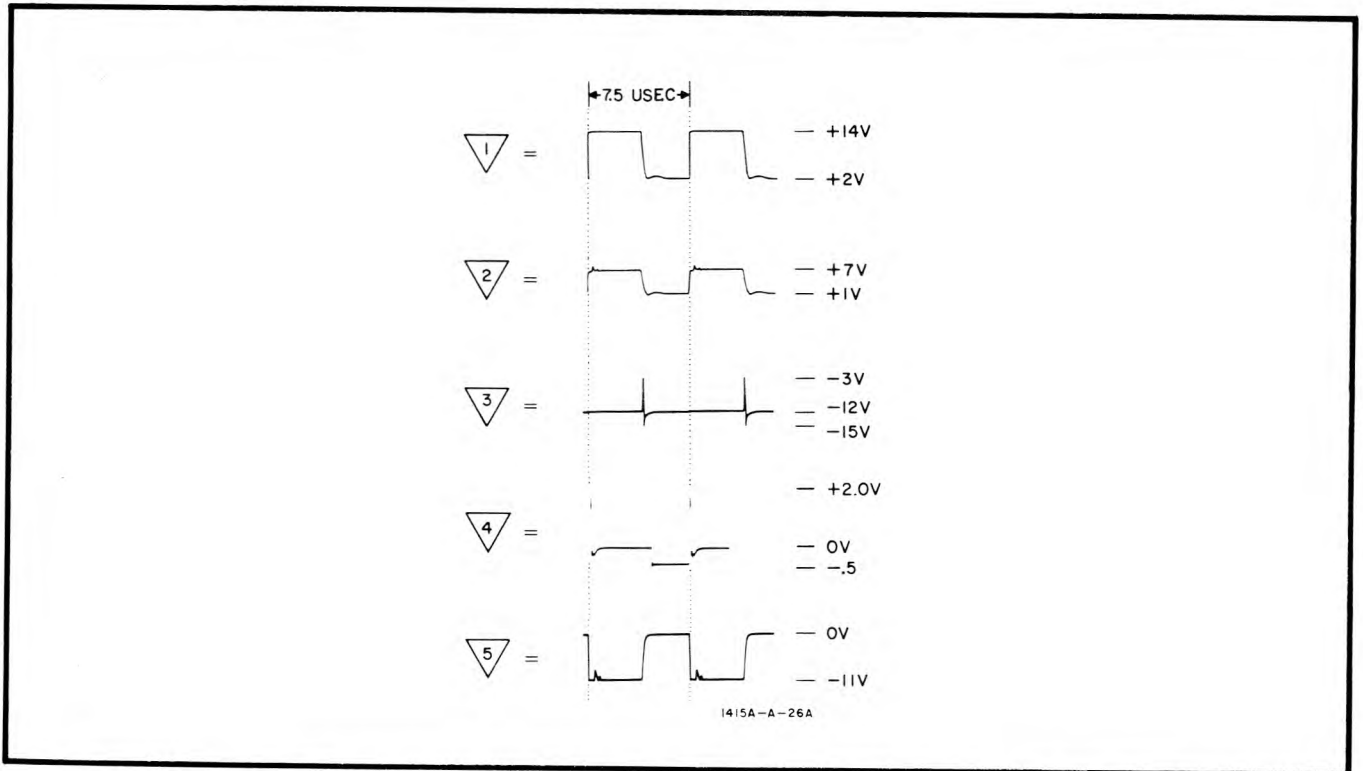

Figure 5-5. Waveforms at Test Points in Step Generator Circuit

- REFERENCE DESIGNATIONS
- A1, 2
  - C101-105, 120-122, 126, 135, 143, 146-148, 151, 153
  - CR101, 121, 123-125
  - DL101
  - J101, 102
  - L101, 102, 120, 135, 150, 160, 170
  - Q101-103, 121-125
  - R101-104, 110-113, 122, 126-129, 135-138, 143-149, 151-155, 161, 162, 171, 172
  - T101

- DELETED:
- C104, 120, 143, 147, 151, 105
  - CR101
  - L101, 102
  - R145, 147

COPYRIGHT 1964 BY HEWLETT-PACKARD CO.  
1415A—STEP GEN—610—

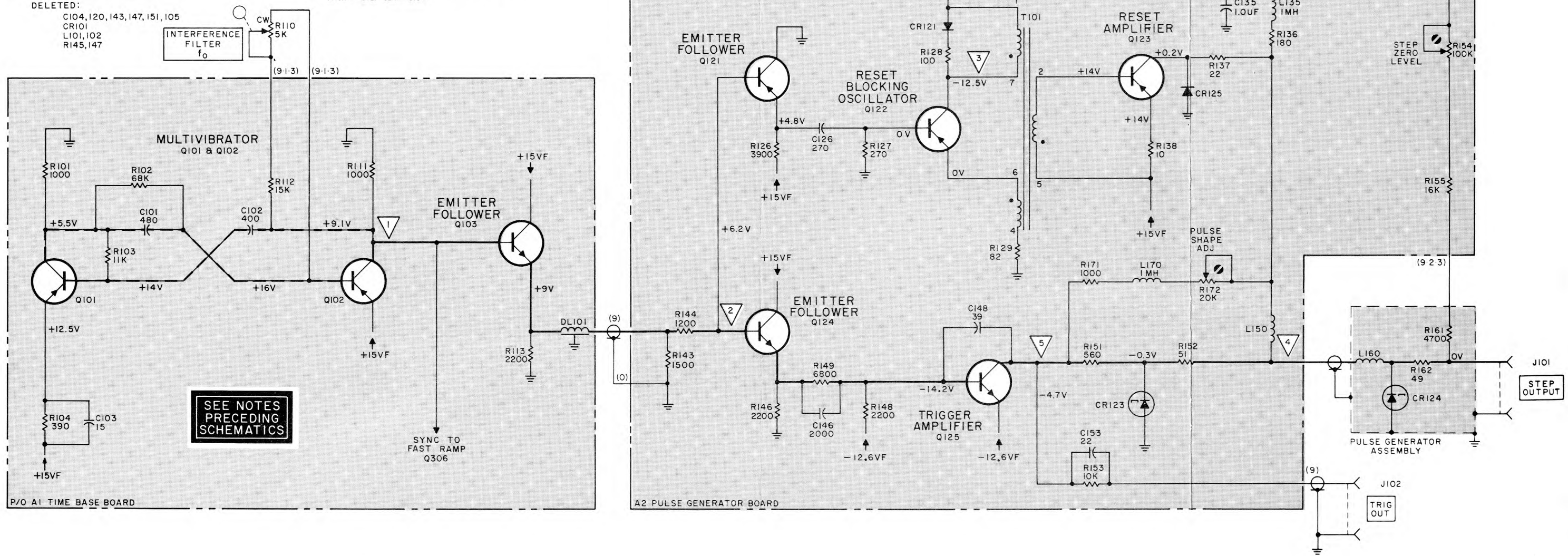

Figure 5-6. Step Generator Schematic Diagram 5-11

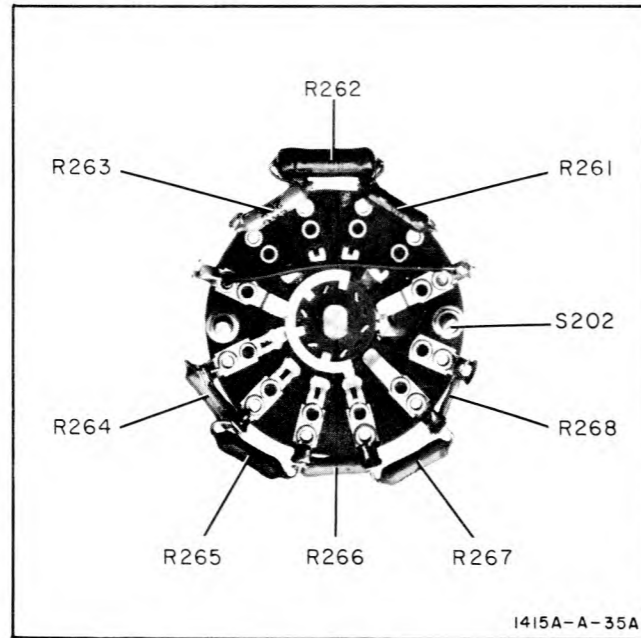

Figure 5-7. Component Locations on A10, Distance/Time Magnifier Switch

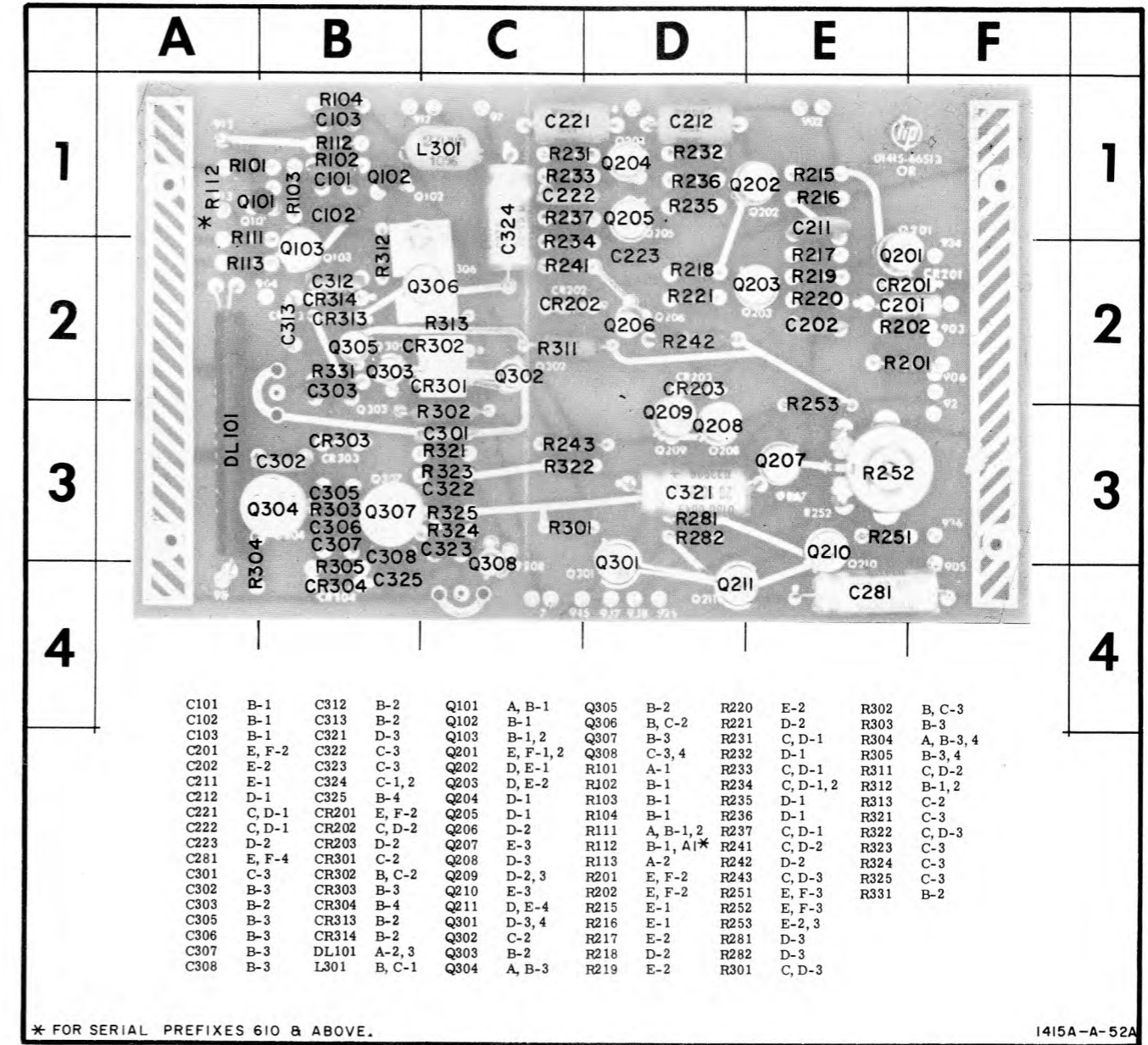

Figure 5-9. Component Locations on A1, Time Base Board

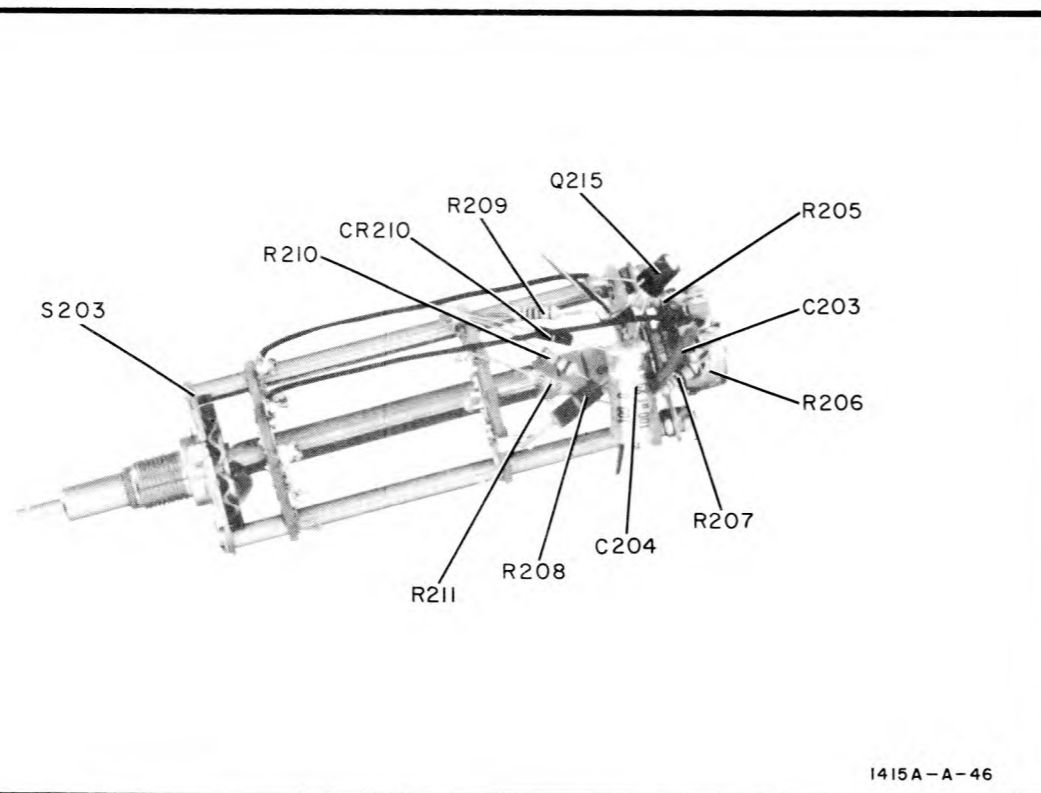

Figure 5-8. Component Locations on A13, Sweep Switch

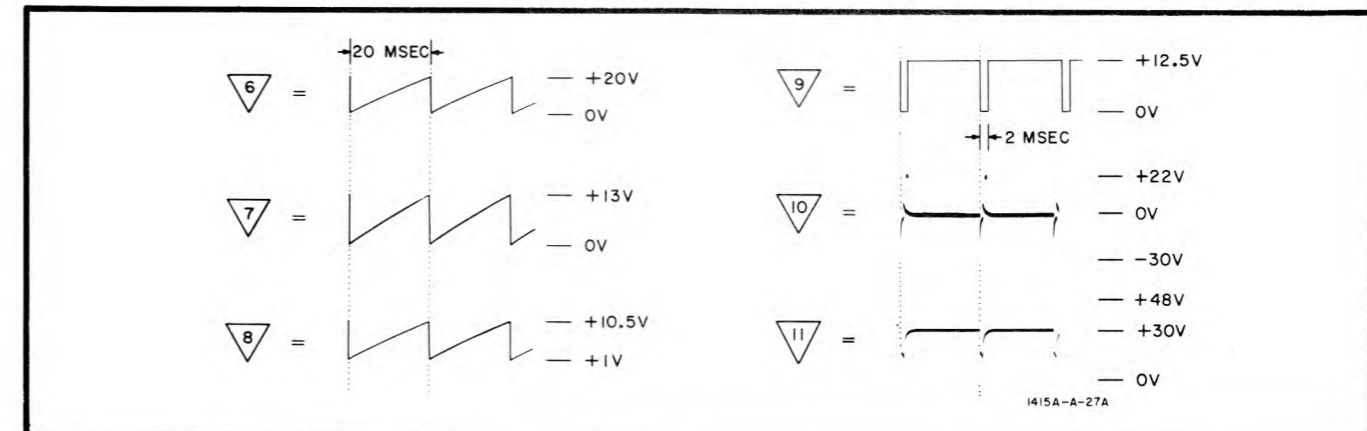

Figure 5-10. Waveforms at Test Points in Slow Ramp and Dot Comparator



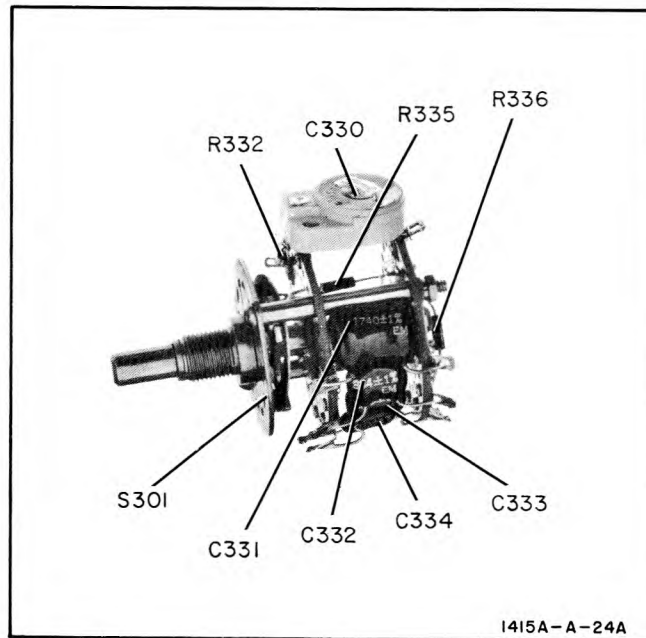

Figure 5-12. Component Locations on A9, Distance/Time CM Line/CM Display Switch

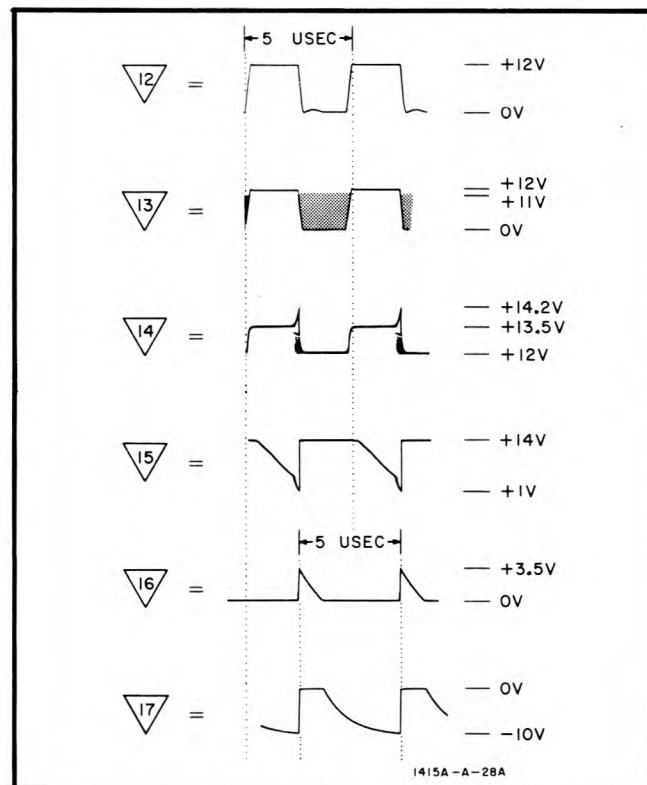

Figure 5-13. Waveforms at Test Points in Fast Ramp and Comparator Circuits.

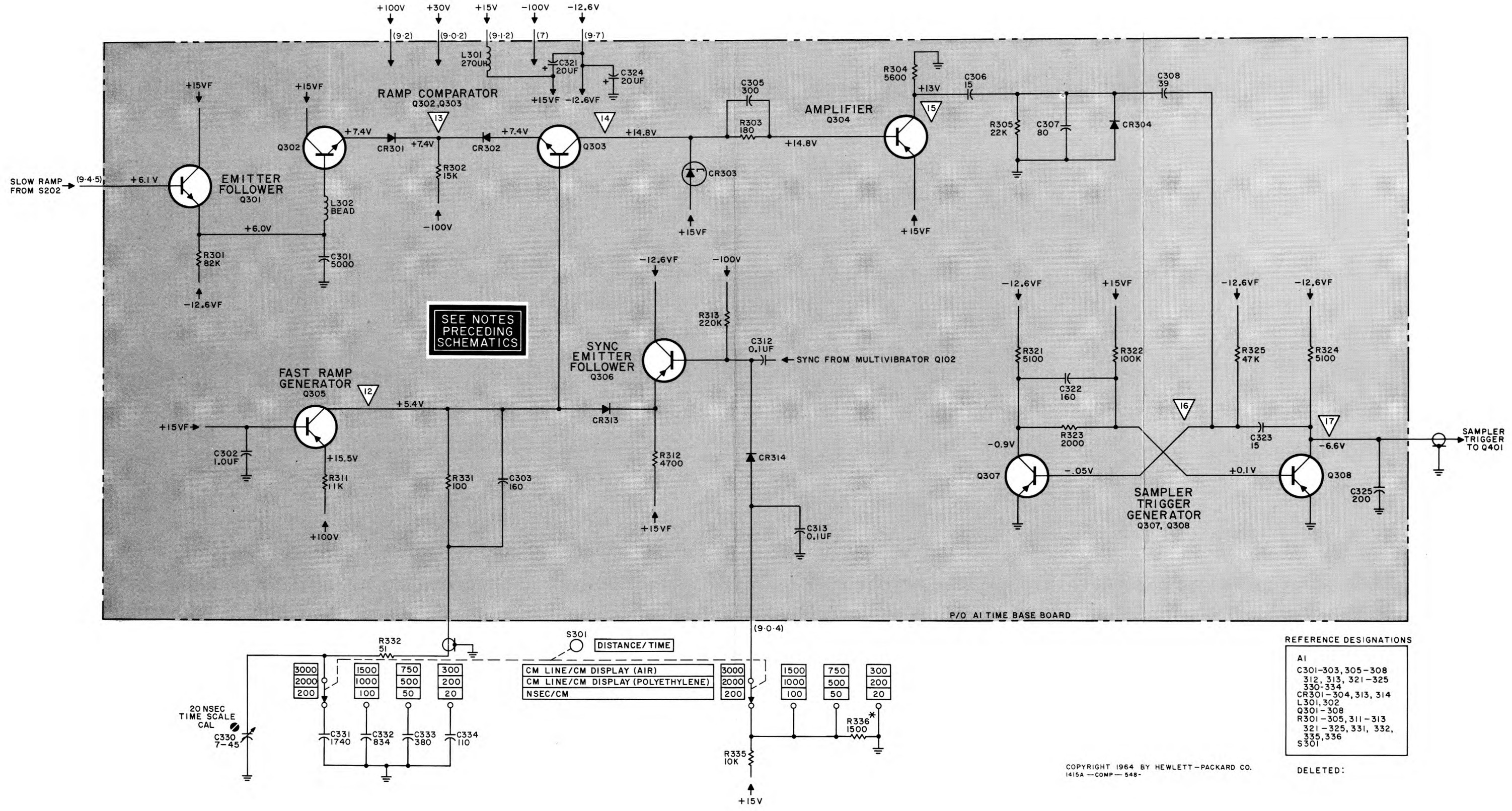

Figure 5-14. Fast Ramp and Comparator Schematic Diagram

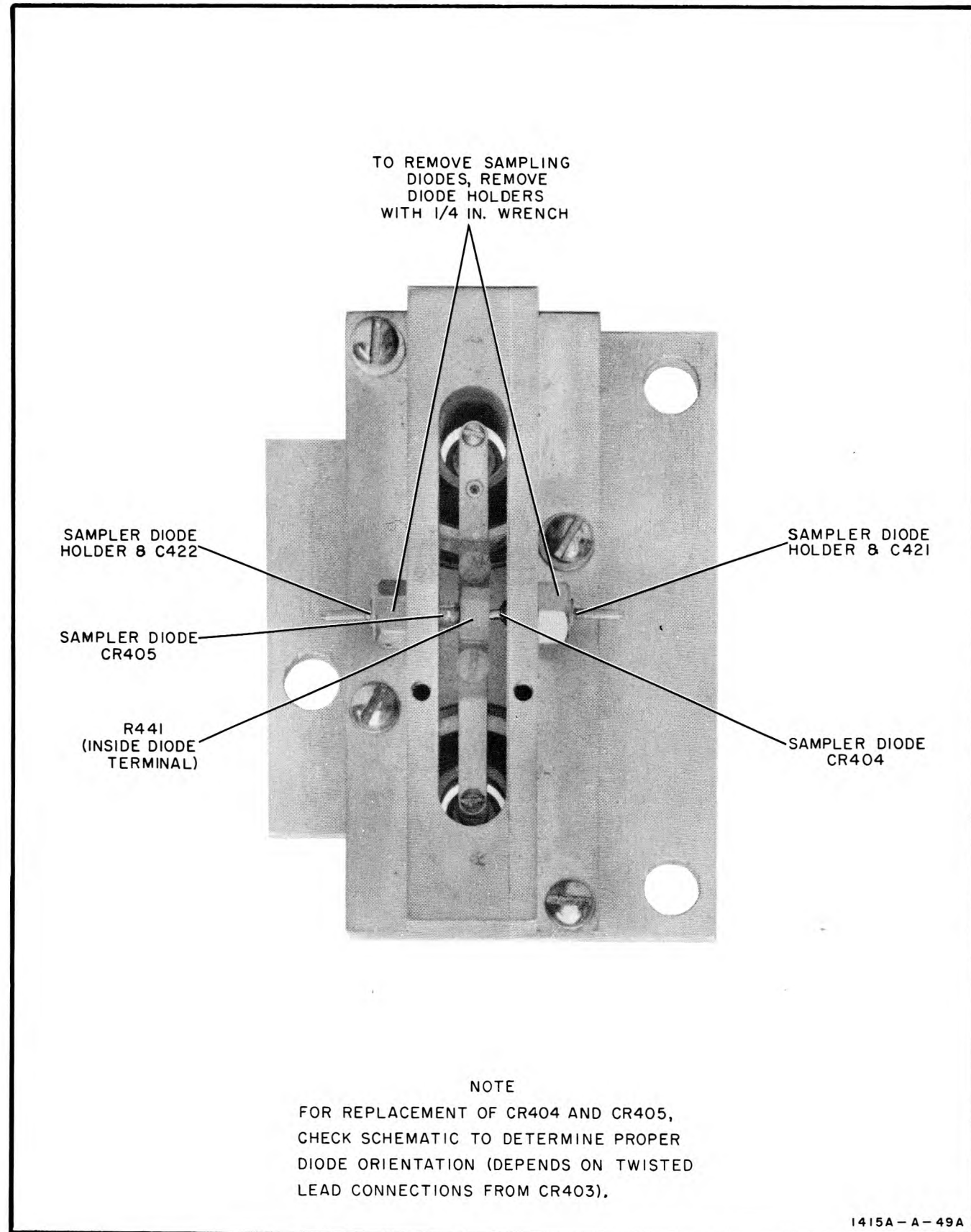

Figure 5-15. Component Locations on Sampler Block Assembly

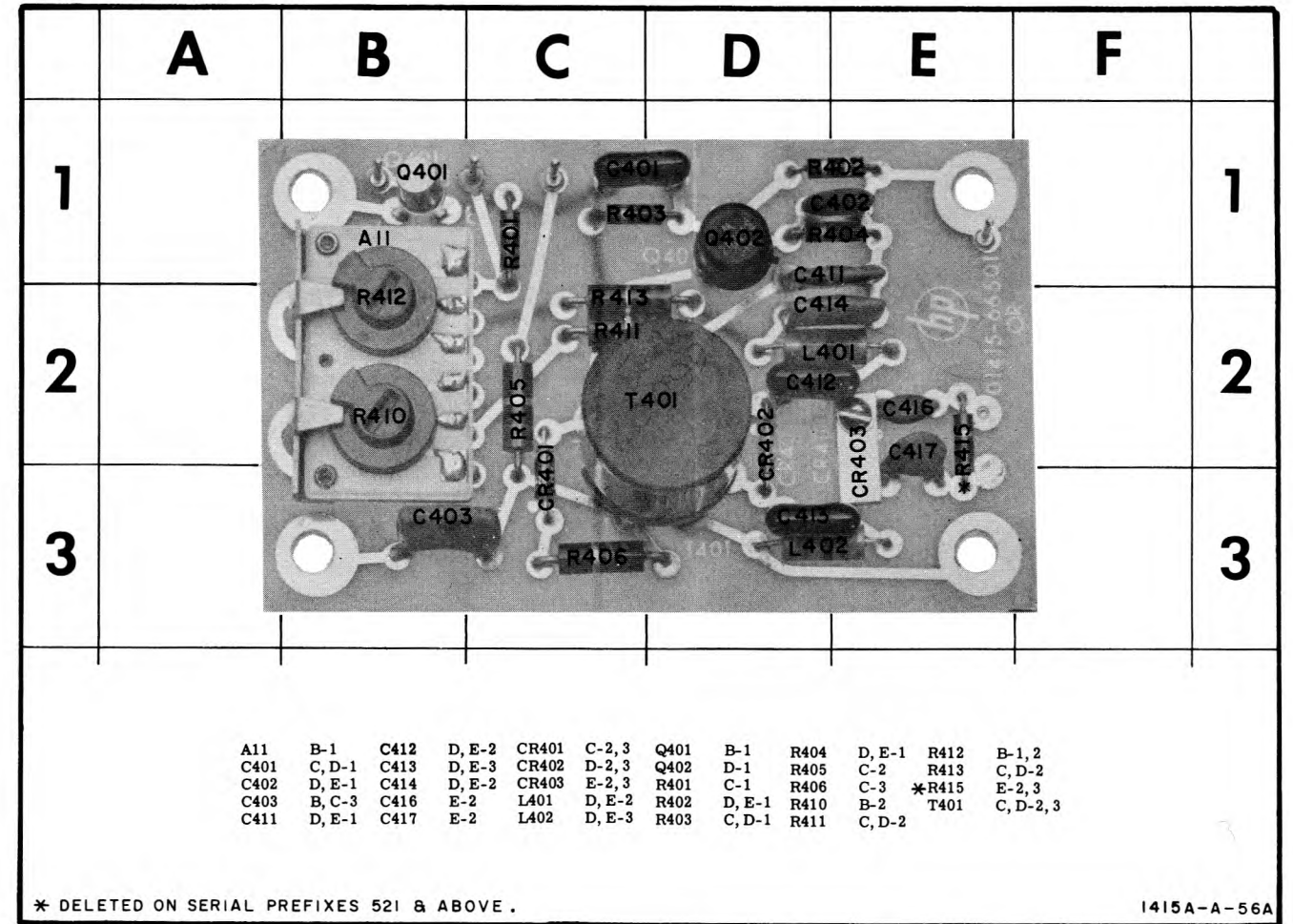

Figure 5-16. Component Locations on A3, Sampler Board

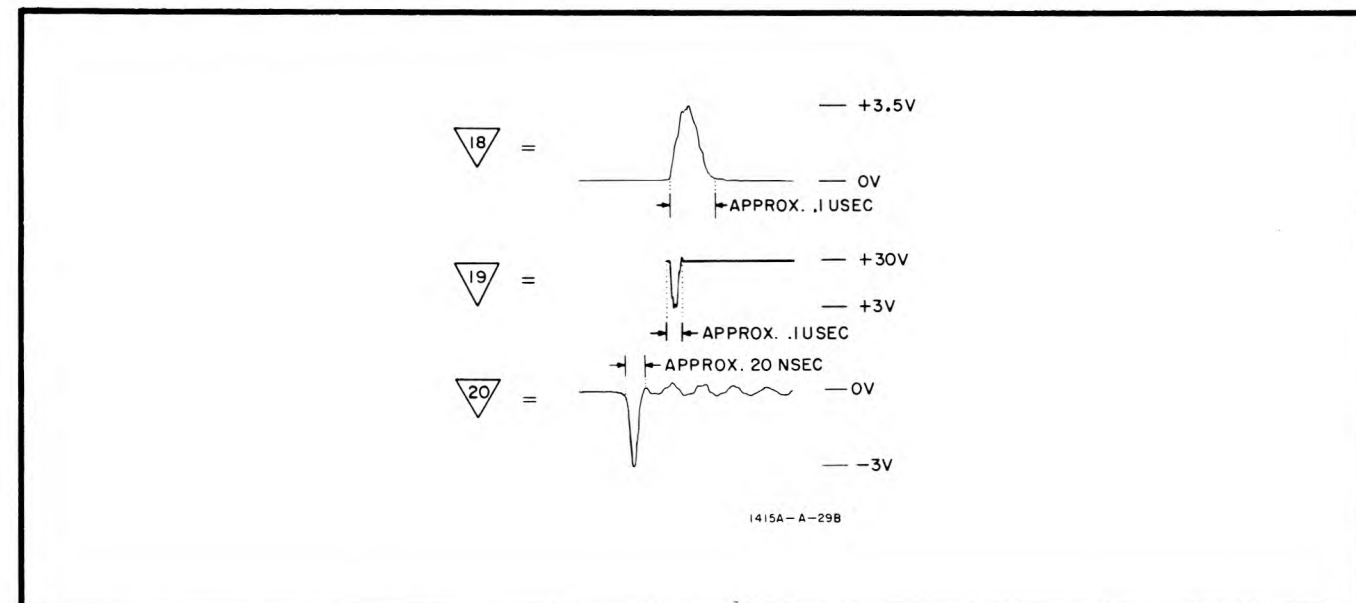
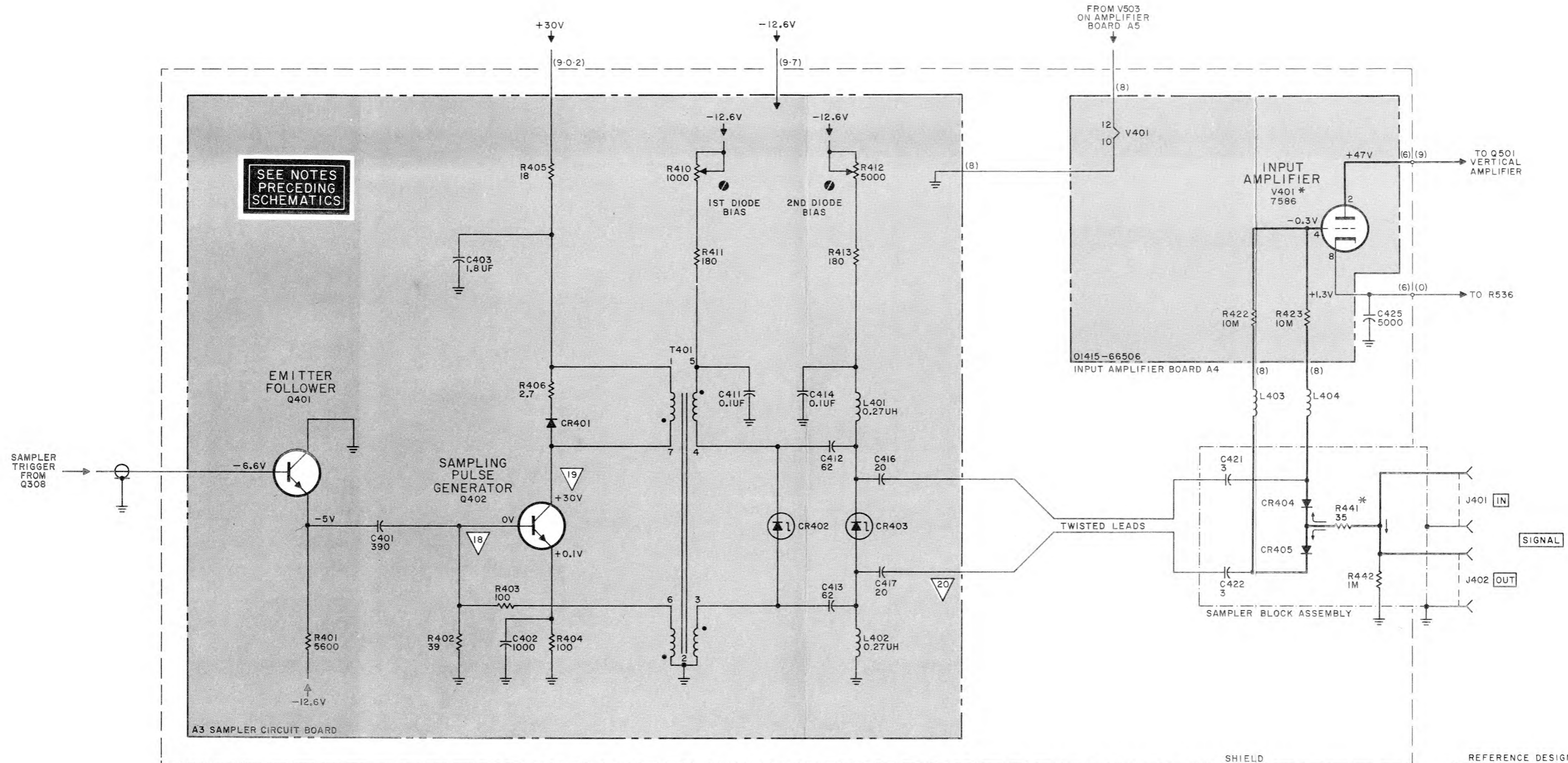

Figure 5-17. Waveforms at Test Points in Sampler Circuit



SEE NOTES  
PRECEDING  
SCHEMATICS

REFERENCE DESIGNATIONS

- A3,4
- C401-403, 411-417, 421, 422, 425
- CR401-405
- J401, 402
- L401-404
- Q401, 402
- R401-406, 410-415, 422, 423, 441, 442
- T401
- V401

DELETED:  
C415  
R414  
R415

COPYRIGHT 1964 BY HEWLETT PACKARD CO.  
1415A-SAMP-521-

Figure 5-18. Sampler Schematic Diagram  
5-17

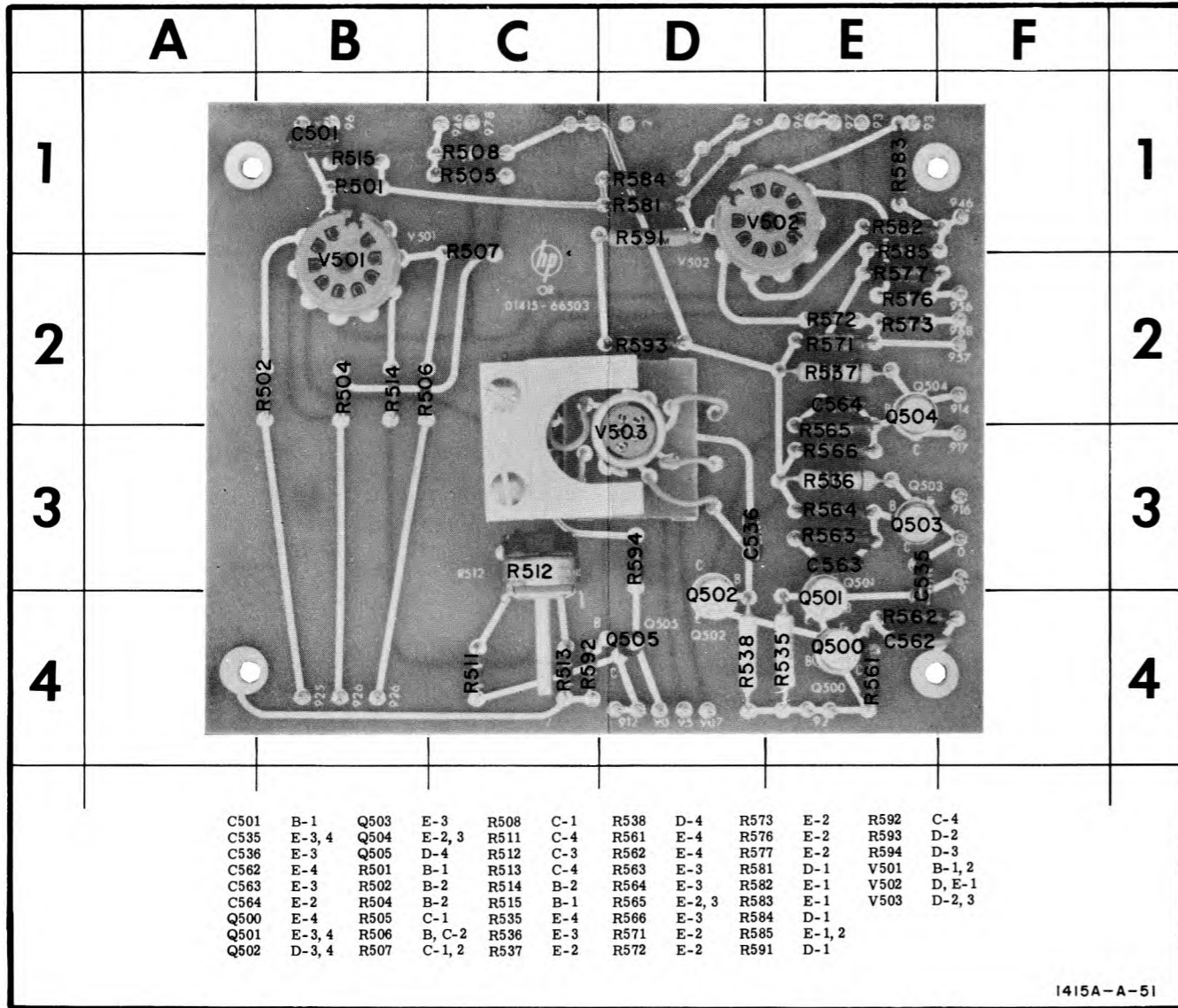

Figure 5-19. Component Locations on A5, Amplifier Board

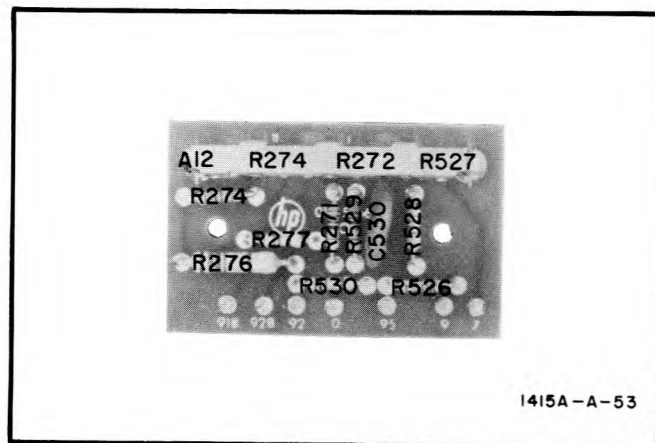

Figure 5-20. Component Locations on A7, Trimmer Board

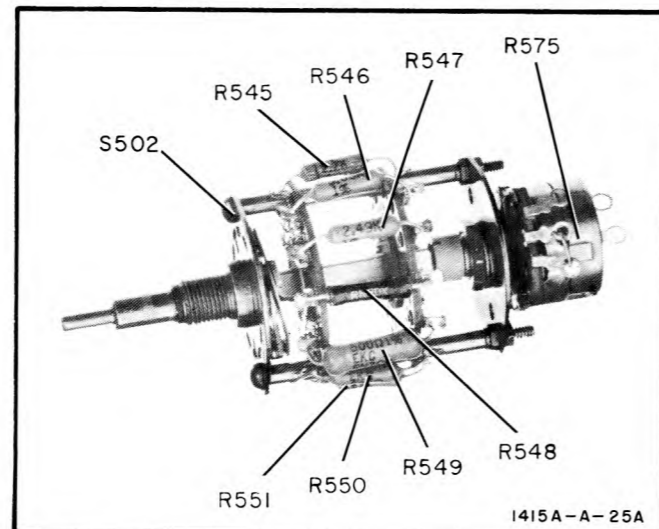

Figure 5-21. Component Locations on A8, Reflection Coefficient Switch

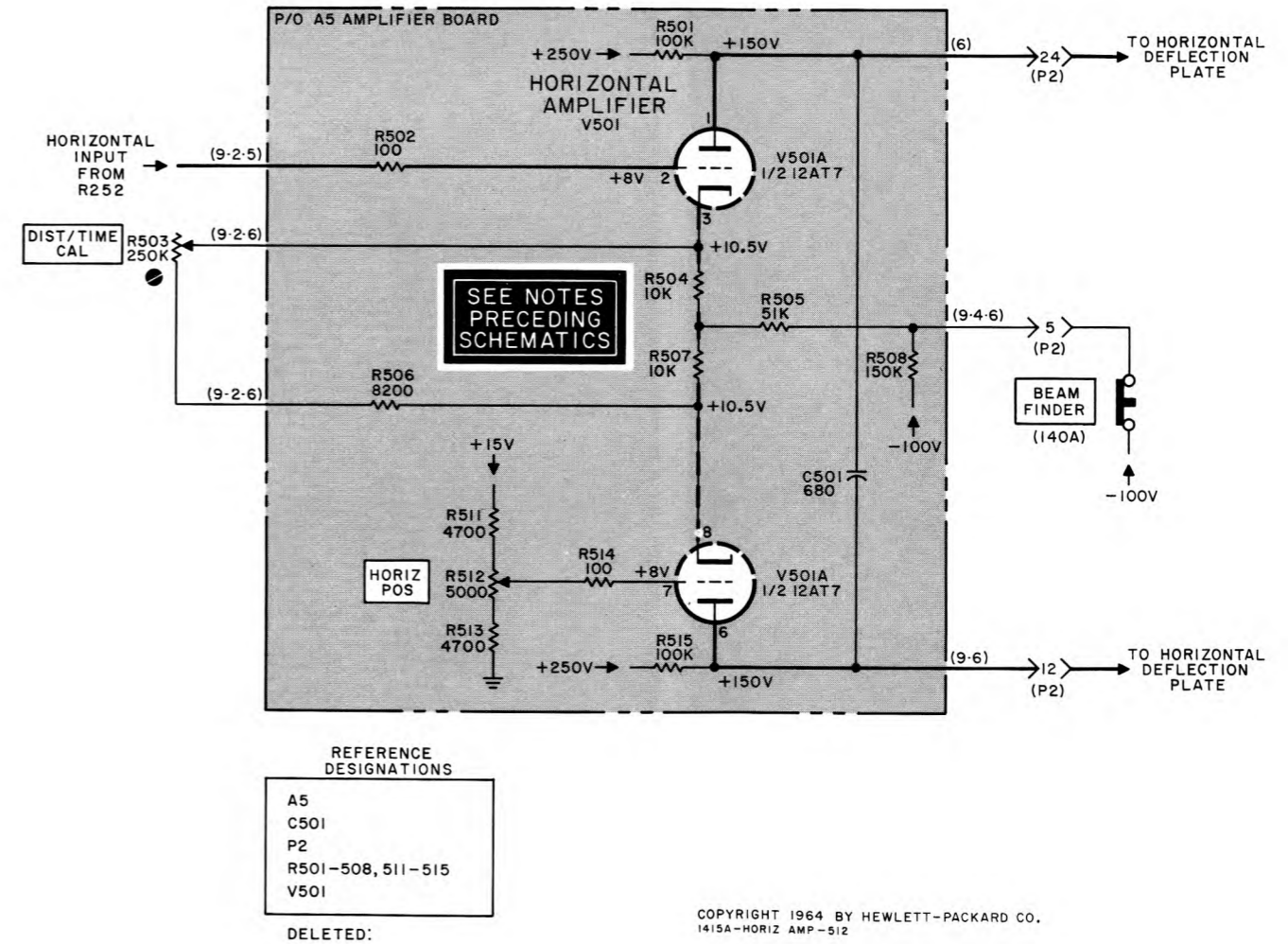

Figure 5-22. Horizontal Amplifier Schematic Diagram

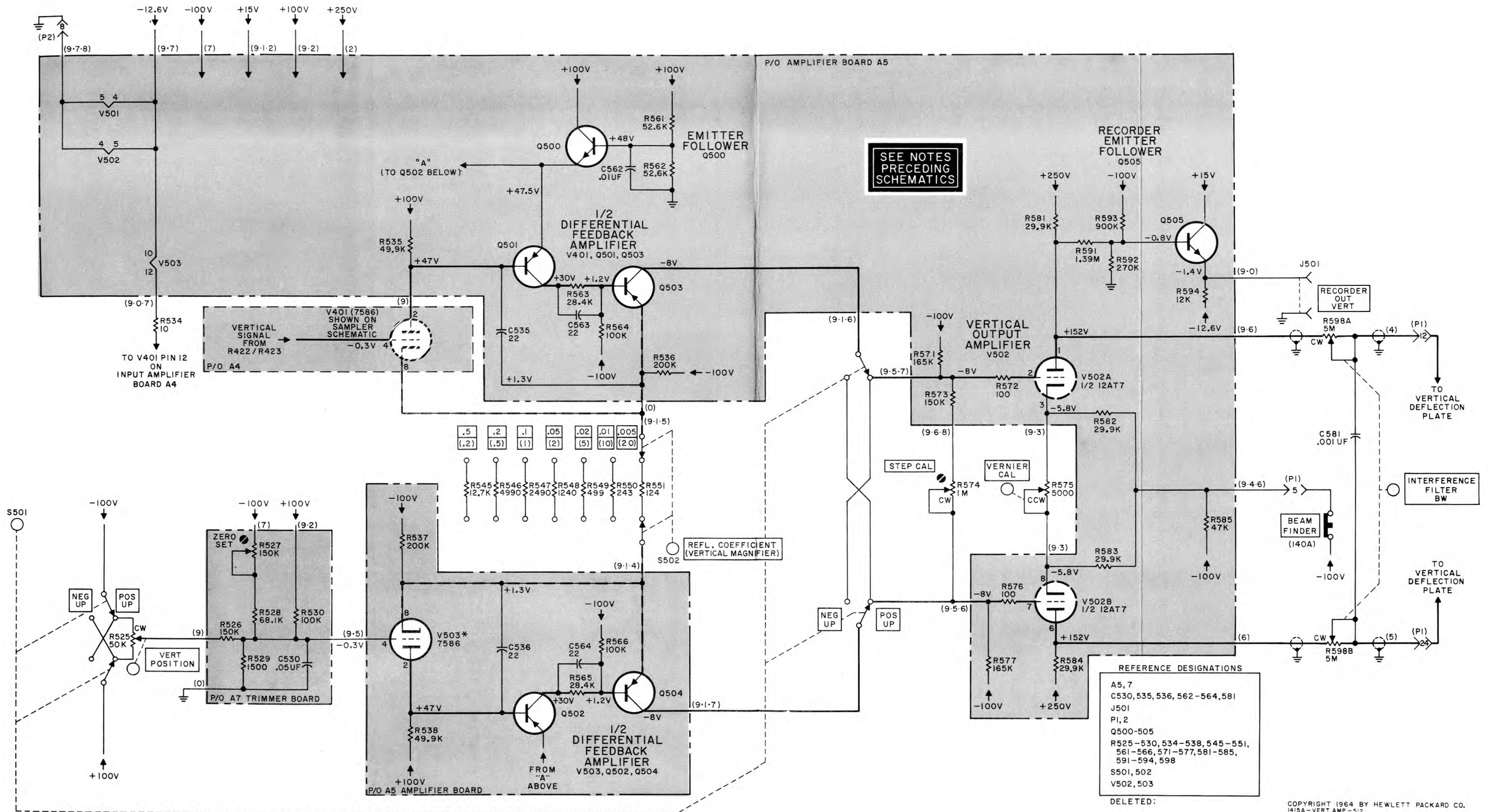

Figure 5-23. Vertical Amplifier Schematic Diagram  
5-19

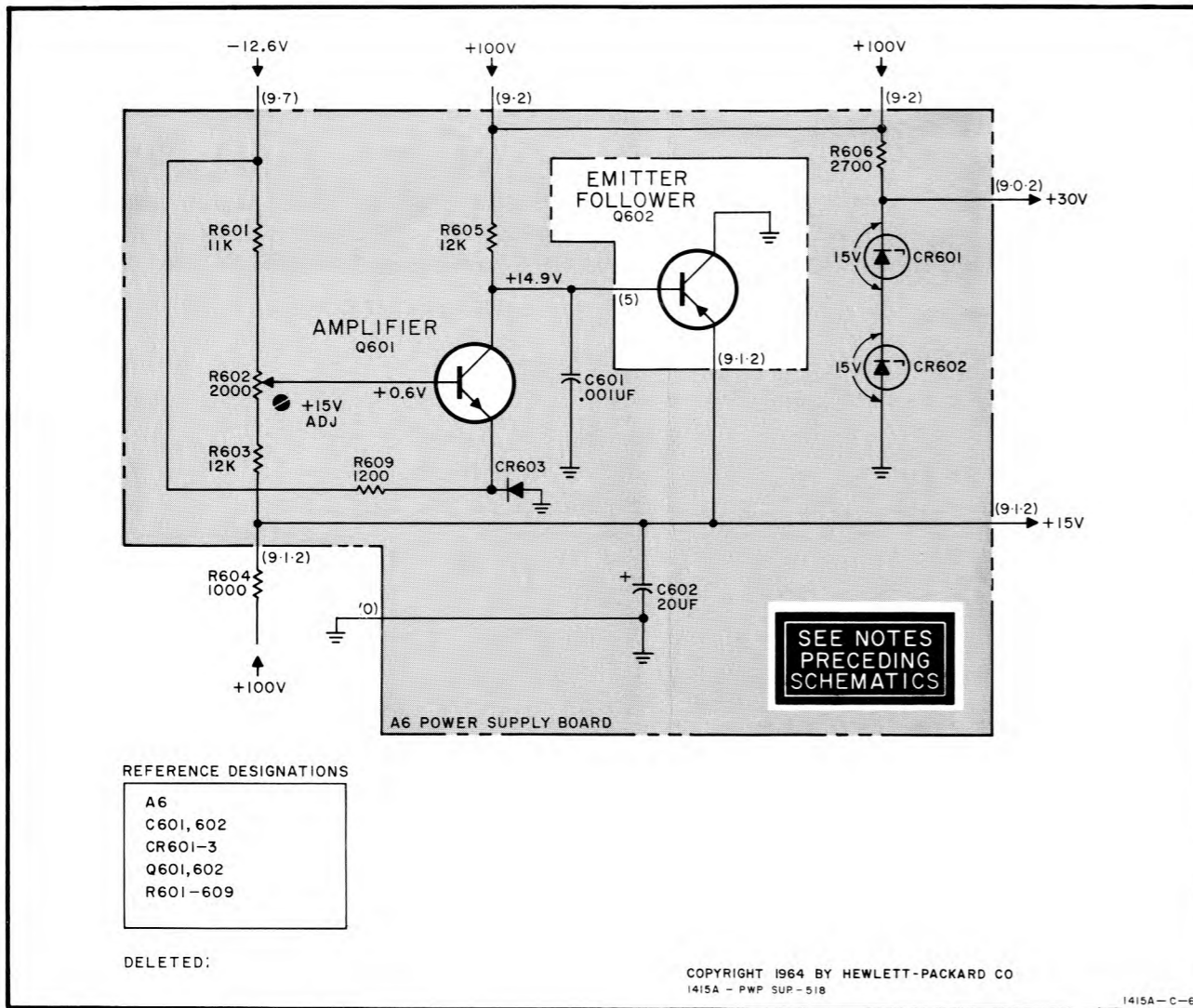

Figure 5-24. Power Supply Schematic Diagram

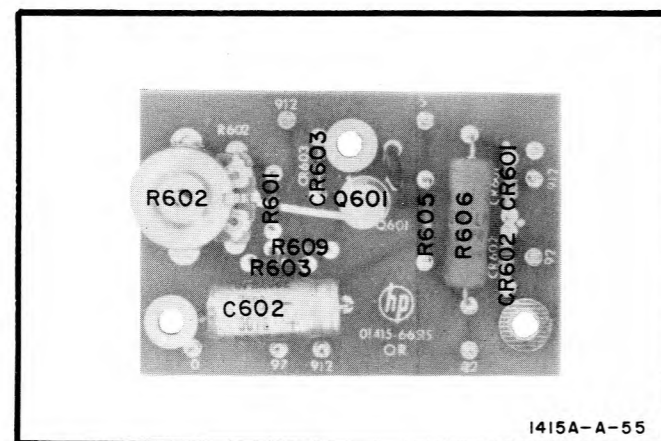

Figure 5-25. Component Locations on A6, Power Supply Board

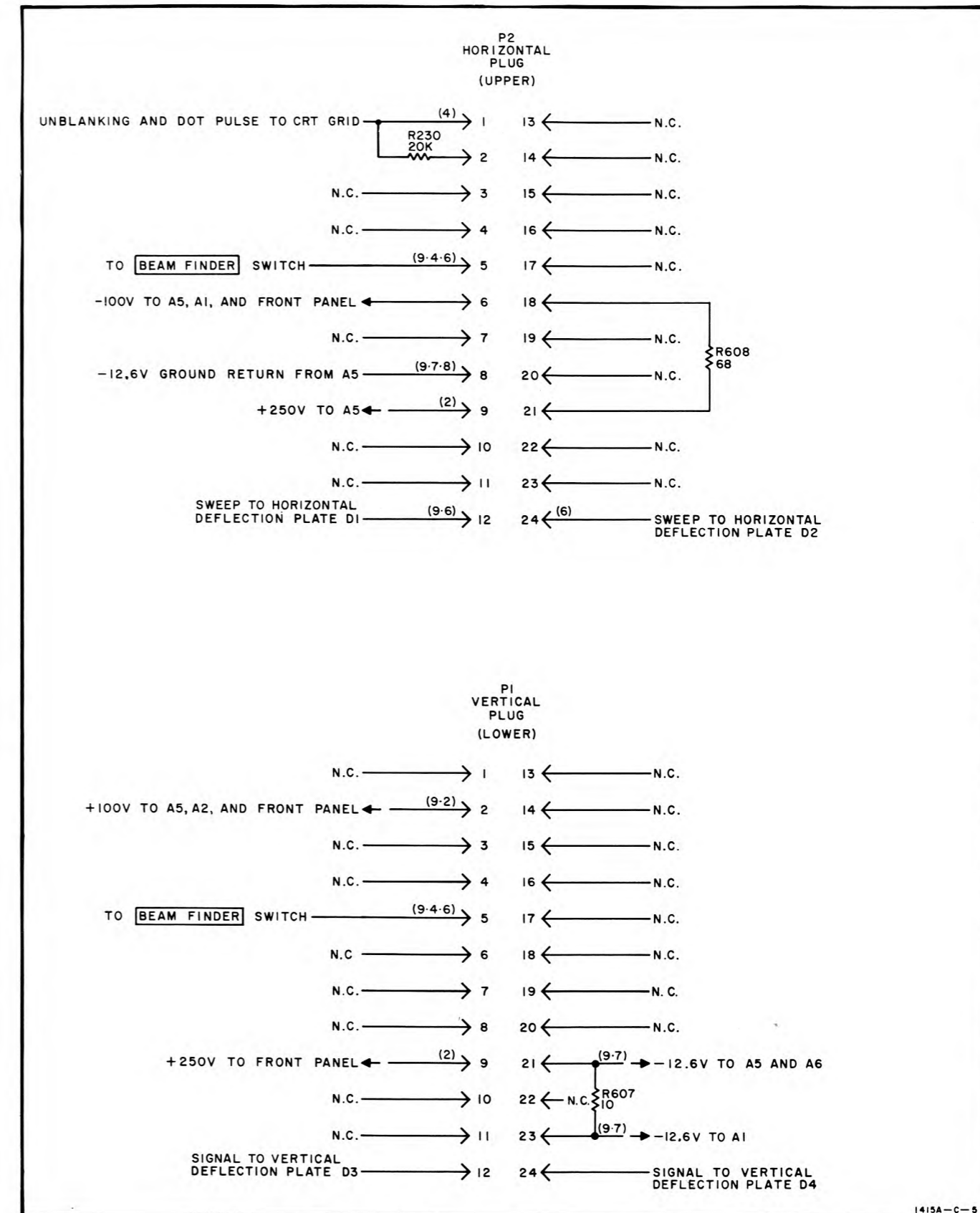

Figure 5-26. Interconnection Plugs Schematic Diagram

## SECTION VI REPLACEABLE PARTS

### 6-1. INTRODUCTION.

6-2. This section contains information for ordering replacement parts. Table 6-1 lists parts in alpha-numerical order of their reference designations and indicates the description and  $\text{\textcircled{P}}$  part number of each component, together with any applicable notes. Parts not identified by a reference designation are listed under miscellaneous at the end of Table 6-1. Table 6-2 lists parts in alpha-numerical order of their  $\text{\textcircled{P}}$  part number and provides the following information on each item:

- a. Description of the part (see list of abbreviations below).
- b. Typical manufacturer of the part in a five-digit code, except where Hewlett-Packard Company is the manufacturer. See list of manufacturer codes in Table 6-3.
- c. Manufacturer's part number.
- d. Total quantity used in the instrument (TQ column).

### 6-3. ORDERING INFORMATION.

6-4. To order a replacement part, address order or inquiry to your local Hewlett-Packard Sales/Service Office (see list of addresses at rear of this manual), and supply the  $\text{\textcircled{P}}$  part number of the item(s) from the tables.

6-5. To order a part not listed in the tables, provide the following information:

- a. Model number of the instrument.
- b. Complete serial number (eight digits) of the instrument.
- c. Description of the part including function and location.

6-6. To order a part from a manufacturer other than Hewlett-Packard Company, provide the complete part description and the manufacturer's part number from Table 6-2.

#### REFERENCE DESIGNATORS

A = assembly	E = misc electronic part	MP = mechanical part	TB = terminal board
B = motor	F = fuse	P = plug	TP = test point
C = capacitor	FL = filter	Q = transistor	V = vacuum tube, neon bulb, photocell, etc.
CP = coupling	J = jack	R = resistor	W = cable
CR = diode	K = relay	RT = thermistor	X = socket
DL = delay line	L = inductor	S = switch	Y = crystal
DS = device signaling (lamp)	M = meter	T = transformer	

#### ABBREVIATIONS

A = amperes	GE = germanium	N/C = normally closed	RMO = rack mount only
A.F.C = automatic frequency control	GL = glass	NE = neon	RMS = root-mean-square
AMPL = amplifier	GRD = ground(ed)	NI PL = nickel plate	
B. F. O. = beat frequency oscillator	H = henries	N/O = normally open	S-B = slow-blow
BE CU = beryllium copper	HEX = hexagonal	NPO = negative positive zero (zero temperature coefficient)	SCR = screw
BH = binder head	HG = mercury	NRFR = not recommended for field replacement	SE = selenium
BP = bandpass	hp = Hewlett-Packard	NSR = not separately replaceable	SECT = section(s)
BRS = brass	HR = hour(s)	OBD = order by description	SEMICON = semiconductor
BWO = backward wave oscillator	IF = intermediate freq	OH = oval head	SI = silicon
CCW = counter-clockwise	IMPG = impregnated	OX = oxide	SIL = silver
CER = ceramic	INCD = incandescent	P = peak	SL = slide
CMO = cabinet mount only	INCL = include(s)	PC = printed circuit	SPL = special
COEF = coefficient	INS = insulation(ed)	PF = picofarads = 10 <sup>-12</sup> farads	SST = stainless steel
COM = common	INT = internal	PH BRZ = phosphor bronze	SR = split ring
COMP = composition	K = kilo = 1000	PHL = Phillips	STL = steel
CONN = connector	LIN = linear taper	PIV = peak inverse voltage	TA = tantalum
CP = cadmium plate	LK WASH = lock washer	P/O = part of	TD = time delay
CRT = cathode-ray tube	LOG = logarithmic taper	POLY = polystyrene	TGL = toggle
CW = clockwise	LPF = low pass filter	PORC = porcelain	TI = titanium
DEPC = deposited carbon	M = milli = 10 <sup>-3</sup>	POS = position(s)	TOL = tolerance
DR = drive	MEG = meg = 10 <sup>6</sup>	POT = potentiometer	TRIM = trimmer
ELECT = electrolytic	METFLM = metal film	PP = peak-to-peak	TWT = traveling wave tube
ENCAP = encapsulated	MFR = manufacturer	PT = point	U = micro = 10 <sup>-6</sup>
EXT = external	MINAT = miniature	RECT = rectifier	VAR = variable
F = farads	MOM = momentary	RF = radio frequency	VDCW = dc working volts
FH = flat head	MTG = mounting	RH = round head	W/ = with
FIL H = fillister head	MY = "mylar"		W = watts
FXD = fixed	N = nano (10 <sup>-9</sup> )		W/O = wirewound
			W/O = without

Table 6-1. Reference Designation Index

Reference Designation	Part No.	Description #	Note
A1	01415-66513	ASSY: ETCHED CKT (TIME BASE)	
A2	01415-66510	ASSY: ETCHED CKT (PULSE GENERATOR)	
A3	01415-66512	ASSY: ETCHED CKT (SAMPLER)	
A4	01415-66506	ASSY: ETCHED CKT (INPUT AMPLIFIER BD)	
A5	01415-66503	ASSY: ETCHED CKT (AMPLIFIER)	
A6	01415-66515	ASSY: ETCHED CKT (POWER SUPPLY)	
A7	01415-66514	ASSY: ETCHED CKT (TRIMMER BD)	
A8	01415-61901	ASSY: SWITCH (VERT SEN)	
A9	01415-61902	ASSY: SWITCH (TIME SCALE)	
A10	01415-61903	ASSY: SWITCH (TIME SCALE MAGNIFIER)	
A11	2100-0797	R: VAR COMP 1K, 5K OHM 20% LIN 1/4W	
A12	2100-0923	R: VAR COMP 2K, 2K, 150K OHM 20% LIN 1/4W	
A13	01415-61904	ASSY: SWITCH (SWEEP)	
C101	0140-0233	C: FXD MICA 480 PF 1% 300VDCW	
C102	0140-0177	C: FXD MICA 400 PF 1% 300VDCW	
C103	0140-0202	C: FXD MICA 15 PF 5% 500VDCW	
C104 THRU C120		NOT ASSIGNED	
C121	0180-0059	C: FXD ELECT 10 $\mu$ f +100 -10% 25VDCW	
C122	0150-0012	C: FXD CER .01 $\mu$ f 20% 1000VDCW	
C123 THRU C125		NOT ASSIGNED	
C126	0140-0206	C: FXD MICA 270 PF 5% 500VDCW	
C127 THRU C134		NOT ASSIGNED	
C135	0160-0127	C: FXD CER 1.0 $\mu$ f 20% 25VDCW	
C136 THRU C145		NOT ASSIGNED	
C146	0140-0180	C: FXD MICA 2000 PF 2% 300VDCW	
C147		NOT ASSIGNED	
C148	0140-0190	C: FXD MICA 39 PF 5% 300VDCW	
C149 THRU C152		NOT ASSIGNED	
C153	0140-0145	C: FXD MICA 22 PF 5% 500VDCW	
C154 THRU C200		NOT ASSIGNED	
C201	0180-0101	C: FXD TA 1.8 $\mu$ f 10% 35VDCW	
C202	0150-0012	C: FXD CER .01 $\mu$ f 20% 1000VDCW	
C203	0150-0121	C: FXD CER 0.1 $\mu$ f +80 -20% 50VDCW	
C204	0180-1706	C: FXD ELECT TA 100 $\mu$ f 20% 25VDCW	
C205 THRU C210		NOT ASSIGNED	
C211	0150-0012	C: FXD CER .01 $\mu$ f 20% 1000VDCW	

# See introduction to this section

Table 6-1. Reference Designation Index (Cont'd)

Reference Designation	Part No.	Description #	Note
C212 C213 THRU C220 C221 C222	0160-2056  0160-0168 0150-0012	C: FXD MY 0.22 $\mu$ f 20% 200VDCW  NOT ASSIGNED C: FXD MY 0.1 $\mu$ f 10% 200VDCW C: FXD CER .01 $\mu$ f 20% 1000VDCW	
C223 C224 THRU C280 C281 C282 THRU C300	0140-0231  0180-0058	C: FXD MICA 440 PF 1% 300VDCW  NOT ASSIGNED C: FXD ELECT 50 $\mu$ f +100 -10% 25VDCW  NOT ASSIGNED	
C301 C302 C303 C304 C305	0150-0014 0160-0127 0140-0218  0140-0225	C: FXD CER .005 $\mu$ f 500VDCW C: FXD CER 1.0 $\mu$ f 20% 25VDCW C: FXD MICA 160 PF 2% 300VDCW NOT ASSIGNED C: FXD MICA 300 PF 1% 300VDCW	
C306 C307 C308 C309 THRU C311	0140-0202 0140-0215 0140-0190  NOT ASSIGNED	C: FXD MICA 15 PF 5% 300VDCW C: FXD MICA 80 PF 2% 300VDCW C: FXD MICA 39 PF 5% 300VDCW  NOT ASSIGNED	
C312 C313 C314 THRU C320 C321	0150-0121 0150-0121  0180-0049	C: FXD CER 0.1 $\mu$ f +80 -20% 50VDCW C: FXD CER 0.1 $\mu$ f +80 -20% 50VDCW  NOT ASSIGNED C: FXD ELECT 20 $\mu$ f 50VDCW	
C322 C323 C324 C325	0140-0218 0140-0202 0180-0076 0140-0220	C: FXD MICA 160 PF 2% 300VDCW C: FXD MICA 15 PF 5% 500VDCW C: FXD ELECT 20 $\mu$ f 25VDCW C: FXD MICA 200 PF 1% 300VDCW	
C326 THRU C329 C330 C331 C332	  0130-0001 0160-0841 0160-0840	NOT ASSIGNED C: VAR CER 7-45 PF N500 C: FXD MICA 1740 PF 1% 300VDCW C: FXD MICA 834 PF 1% 100VDCW	
C333 C334 C335 THRU C400 C401	0160-2167 0160-0839  0140-0200	C: FXD MICA 380 PF 1% 300VDCW C: FXD MICA 110 PF 1% 300VDCW  NOT ASSIGNED C: FXD MICA 390 PF 5% 300VDCW	
C402 C403 C404 THRU C410 C411	0150-0069 0180-0101  0150-0121	C: FXD CER .001 $\mu$ f +100 -20% 500VDCW C: FXD ELECT TA 1.8 $\mu$ f 10% 35VDCW  NOT ASSIGNED C: FXD CER 0.1 $\mu$ f +80 -20% 50VDCW	

# See introduction to this section

Table 6-1. Reference Designation Index (Cont'd)

Reference Designation	Part No.	Description #	Note
C412	0150-0087	C: FXD CER 62 PF 10% 500VDCW	
C413	0150-0087	C: FXD CER 62 PF 10% 500VDCW	
C414	0150-0121	C: FXD CER 0.1 $\mu$ f +80 -20% 50VDCW	
C415		NOT ASSIGNED	
C416	0150-0035	C: FXD CER 20 PF 10% 600VDCW	
C417	0150-0035	C: FXD CER 20 PF 10% 600VDCW	
C418 THRU			
C420		NOT ASSIGNED	
C421	00188-68201	ASSY: CAPACITOR	
C422	00188-68201	ASSY: CAPACITOR	
C423 AND			
C424		NOT ASSIGNED	
C425	0150-0014	C: FXD CER 5000 PF 500VDCW	
C426 THRU			
C500		NOT ASSIGNED	
C501	0140-0208	C: FXD MICA 680 PF 5% 300VDCW	
C502 THRU			
C529		NOT ASSIGNED	
C530	0150-0052	C: FXD CER 0.05 $\mu$ f 20% 400VDCW	
C531 THRU			
C534		NOT ASSIGNED	
C535	0140-0145	C: FXD MICA 22 PF 5% 500VDCW	
C536	0140-0145	C: FXD MICA 22 PF 5% 500VDCW	
C537 THRU			
C561		NOT ASSIGNED	
C562	0150-0012	C: FXD CER .01 $\mu$ f 20% 1000VDCW	
C563	0140-0145	C: FXD MICA 22 PF 5% 500VDCW	
C564	0140-0145	C: FXD MICA 22 PF 5% 500VDCW	
C565 THRU			
C580		NOT ASSIGNED	
C581	0150-0069	C: FXD CER .001 $\mu$ f +100 -20% 500VDCW	
C582 THRU			
C600		NOT ASSIGNED	
C601	0150-0069	C: FXD CER .001 $\mu$ f +100 -20% 500VDCW	
C602	0180-0076	C: FXD ELECT 20 $\mu$ f 25VDCW	
CR121	1910-0016	DIODE: GE	
CR122		NOT ASSIGNED	
CR123	1912-0012	DIODE: GE TUNNEL	
CR124	1912-0008	DIODE: GE TUNNEL	
CR125	1901-0040	DIODE: SI	
CR126	THRU		
CR200		NOT ASSIGNED	
CR201	1903-0005	DIODE: SI	
CR202	1902-0055	DIODE: AVALANCE 14.7V	
CR203	1912-0007	DIODE: GE TUNNEL 1N3714	

# See introduction to this section

Table 6-1. Reference Designation Index (Cont'd)

Reference Designation	Part No.	Description #	Note
CR204 THRU CR209 CR210 CR211 THRU CR300	1901-0179	NOT ASSIGNED DIODE: SI  NOT ASSIGNED	
CR301 CR302 CR303 CR304 CR305 THRU CR312	1910-0016 1910-0016 1912-0007 1910-0016	DIODE: GE DIODE: GE DIODE: GE TUNNEL 1N3714 DIODE: GE  NOT ASSIGNED	
CR313 CR314 CR315 THRU CR400 CR401	1901-0115 1901-0040  1910-0016	DIODE: SI DIODE: SI  NOT ASSIGNED DIODE: GE	
CR402 CR403 CR404 CR405	1901-0092 1901-0155 1901-0163 1901-0163	DIODE: SI STEP RECOVERY DIODE: SI STEP RECOVERY DIODE: SI SAMPLING DIODE: SI SAMPLING	
CR406 THRU CR600 CR601 CR602 CR603	  1902-0055 1902-0055 1901-0040	 NOT ASSIGNED DIODE: SI AVALANCHE 14.7V DIODE: SI AVALANCHE 14.7V DIODE: SI	
DL101	9190-0007	DELAY LINE: 1000 OHM 0.14 MICROSECONDS	
J101 J102 J103 THRU J200 J201	 1250-0118  1250-0118	NSR CONNECTOR: BNC  NOT ASSIGNED CONNECTOR: BNC	
J202 THRU J400 J401 J402	   	NOT ASSIGNED NSR NSR	
J403 THRU J500 J501	 1250-0118	NOT ASSIGNED CONNECTOR: BNC	
L120 L121 THRU L134 L135 L136 THRU L149	9140-0137  9140-0137	INDUCTOR: FXD RF 1 MH  NOT ASSIGNED INDUCTOR: FXD RF 1 MH  NOT ASSIGNED	

# See introduction to this section

Table 6-1. Reference Designation Index (Cont'd)

Reference Designation	Part No.	Description #	Note
L150 L151 THRU L159 L160 L161 THRU L169	9170-0029  9170-0031	INDUCTOR: FERRITE BEAD (5 REQUIRED)  NOT ASSIGNED INDUCTOR: FERRITE BEAD (4 REQUIRED)  NOT ASSIGNED	
L170 L171 THRU L300 L301 L302 L303 THRU L400 L401 L402 L403 L404	9140-0137  9140-0075 9170-0029  9140-0095 9140-0095 9170-0029 9170-0029	COIL: FXD RF 1 MH  NOT ASSIGNED COIL: FXD RF 270 $\mu$ h 10% INDUCTOR: FERRITE BEAD  NOT ASSIGNED COIL: FXD RF 0.27 $\mu$ h COIL: FXD RF 0.27 $\mu$ h INDUCTOR: FERRITE BEAD (3 REQUIRED) INDUCTOR: FERRITE BEAD (3 REQUIRED)	
P1 P2	1251-0055 1251-0055	CONNECTOR: MALE 24 PIN CONNECTOR: MALE 24 PIN	
Q101 Q102 Q103 Q104 THRU Q120	1853-0010 1853-0010 1851-0017	TRANSISTOR: SI PNP TRANSISTOR: SI PNP TRANSISTOR: GE NPN 2N1304  NOT ASSIGNED	
Q121 Q122 Q123 Q124 Q125	1850-0158 1850-0158 1850-0158 1854-0005 1854-0005	TRANSISTOR: GE PNP 2N2635 TRANSISTOR: GE PNP 2N2635 TRANSISTOR: GE PNP 2N2635 TRANSISTOR: SI NPN 2N708 TRANSISTOR: SI NPN 2N708	
Q126 THRU Q200 Q201 Q202 Q203	 1854-0022 1854-0003 1854-0003	NOT ASSIGNED TRANSISTOR: SI NPN 2N918 TRANSISTOR: SI NPN TRANSISTOR: SI NPN	
Q204 Q205 Q206 Q207	1850-0128 1850-0040 1850-0096 1853-0001	TRANSISTOR: GE PNP 2N398B TRANSISTOR: GE PNP 2N383 TRANSISTOR: GE PNP 2N2189 TRANSISTOR: SI PNP	
Q208 Q209 Q210 Q211	1851-0024 1851-0024 1850-0062 1850-0062	TRANSISTOR: GE NPN 2N388A TRANSISTOR: GE NPN 2N388A TRANSISTOR: GE PNP TRANSISTOR: GE PNP	
Q212 THRU Q214 Q215 Q216 THRU Q300	 1854-0033	NOT ASSIGNED TRANSISTOR: SI NPN 2N3391  NOT ASSIGNED	

# See introduction to this section

Table 6-1. Reference Designation Index (Cont'd)

Reference Designation	Part No.	Description #	Note
Q301	1851-0024	TRANSISTOR: GE NPN 2N388A	
Q302	1854-0054	TRANSISTOR: SI NPN	
Q303	1854-0054	TRANSISTOR: SI NPN	
Q304	1850-0158	TRANSISTOR: GE PNP 2N2635	
Q305	1850-0096	TRANSISTOR: GE PNP 2N2189	
Q306	1850-0070	TRANSISTOR: GE PNP 2N1373	
Q307	1850-0158	TRANSISTOR: GE PNP 2N2635	
Q308	1850-0158	TRANSISTOR: GE PNP 2N2635	
Q309 THRU Q400		NOT ASSIGNED	
Q401	1854-0005	TRANSISTOR: SI NPN 2N708	
Q402	1854-0013	TRANSISTOR: SI NPN 2N2218A	
Q403 THRU Q499		NOT ASSIGNED	
Q500	1854-0003	TRANSISTOR: SI NPN	
Q501	1850-0101	TRANSISTOR: GE PNP SPL 2N582	
Q502	1850-0101	TRANSISTOR: GE PNP SPL 2N582	
Q503	1850-0040	TRANSISTOR: GE PNP 2N383	
Q504	1850-0040	TRANSISTOR: GE PNP 2N383	
Q505	1854-0033	TRANSISTOR: SI NPN 2N3391	
Q506 THRU Q600		NOT ASSIGNED	
Q601	1854-0003	TRANSISTOR: SI NPN	
Q602	1850-0143	TRANSISTOR: GE PNP	
R101	0684-1021	R: FXD COMP 1K OHMS 10% 1/4W	
R102	0684-6831	R: FXD COMP 68K OHMS 10% 1/4W	
R103	0683-1135	R: FXD COMP 11K OHMS 5% 1/4W	
R104	0683-3915	R: FXD COMP 390 OHMS 5% 1/4W	
R105 THRU R109		NOT ASSIGNED	
R110	2100-0421	R: VAR COMP 5K OHMS 20% 3/10W	
R111	0684-1021	R: FXD COMP 1K OHMS 10% 1/4W	
R112	0684-1531	R: FXD COMP 15K OHMS 10% 1/4W	
R113	0684-2221	R: FXD COMP 2200 OHMS 10% 1/4W	
R114 THRU R121		NOT ASSIGNED	
R122	0684-1211	R: FXD COMP 120 OHMS 10% 1/4W	
R123 THRU R125		NOT ASSIGNED	
R126	0684-3921	R: FXD COMP 3900 OHMS 10% 1/4W	
R127	0683-2715	R: FXD COMP 270 OHMS 5% 1/4W	
R128	0684-1011	R: FXD COMP 100 OHMS 10% 1/4W	
R129	0683-8205	R: FXD COMP 82 OHMS 5% 1/4W	
R130 THRU R134		NOT ASSIGNED	

# See introduction to this section

Table 6-1. Reference Designation Index (Cont'd)

Reference Designation	f <sub>p</sub> Part No.	Description #	Note
R135	2100-0118	R: VAR COMP 100 OHMS 20% LIN 0.3W (PULSE STABILITY)	
R136	0761-0014	R: FXD MET FLM 180 OHMS 5% 1W	
R137	0684-2201	R: FXD COMP 22 OHMS 10% 1/4W	
R138	0684-1001	R: FXD COMP 10 OHMS 10% 1/4W	
R139	THRU		
R142		NOT ASSIGNED	
R143	0683-1525	R: FXD COMP 1500 OHMS 5% 1/4W	
R144	0683-1225	R: FXD COMP 1200 OHMS 5% 1/4W	
R145		NOT ASSIGNED	
R146	0684-2221	R: FXD COMP 2200 OHMS 10% 1/4W	
R147		NOT ASSIGNED	
R148	0684-2221	R: FXD COMP 2200 OHMS 10% 1/4W	
R149	0684-6821	R: FXD COMP 6800 OHMS 10% 1/4W	
R150		NOT ASSIGNED	
R151	0683-5615	R: FXD COMP 560 OHMS 5% 1/4W	
R152	0683-5105	R: FXD COMP 51 OHMS 5% 1/4W	
R153	0684-1031	R: FXD COMP 10K OHMS 10% 1/4W	
R154	2100-0836	R: VAR COMP 100K OHMS 20% 1/4W	
R155	0686-1635	R: FXD COMP 16K OHMS 5% 1/2W	
R156	THRU		
R160		NOT ASSIGNED	
R161	0684-4721	R: FXD COMP 4700 OHMS 10% 1/4W	
R162	0677-0004	R: FXD COMP 49 OHMS 1% 1/8W	
R163	THRU		
R170		NOT ASSIGNED	
R171	0683-1025	R: FXD COMP 1K OHMS 5% 1/4W	
R172	2100-0397	R: VAR COMP 20K OHMS 20% 1/4W	
R173	THRU		
R200		NOT ASSIGNED	
R201	0686-5135	R: FXD COMP 51K OHMS 5% 1/2W	
R202	0683-5145	R: FXD COMP 510K OHMS 5% 1/4W	
R203	AND		
R204		NOT ASSIGNED	
R205	0757-0426	R: FXD MET FLM 1300 OHMS 1% 1/8W	
R206	2100-0421	R: VAR COMP 5K OHMS 20% 1/5W	
R207	0757-0413	R: FXD MET FLM 392 OHMS 1% 1/8W	
R208	0686-3055	R: FXD COMP 3 MEGOHMS 5% 1/2W	
R209	0757-0442	R: FXD MET FLM 10K OHMS 1% 1/8W	
R210	0757-0452	R: FXD MET FLM 27.4K OHMS 1% 1/8W	
R211	0757-0414	R: FXD MET FLM 432 OHMS 1% 1/8W	
R212	THRU		
R214		NOT ASSIGNED	
R215	0684-6821	R: FXD COMP 6800 OHMS 10% 1/4W	
R216	0684-8221	R: FXD COMP 8200 OHMS 10% 1/4W	
R217	0684-2231	R: FXD COMP 22K OHMS 10% 1/4W	
R218	0683-6815	R: FXD COMP 680 OHMS 5% 1/4W	
R219	0684-6821	R: FXD COMP 6800 OHMS 10% 1/4W	

# See introduction to this section

Table 6-1. Reference Designation Index (Cont'd)

Reference Designation	Part No.	Description #	Note
R220	0684-2241	R: FXD COMP 220K OHMS 10% 1/4W	
R221	0684-8231	R: FXD COMP 82K OHMS 10% 1/4W	
R222 THRU R229		NOT ASSIGNED	
R230	0683-2035	R: FXD COMP 20K OHMS 5% 1/4W	
R231	0684-6821	R: FXD COMP 6800 OHMS 10% 1/4W	
R232	0684-8221	R: FXD COMP 8200 OHMS 10% 1/4W	
R233	0684-2231	R: FXD COMP 22K OHMS 10% 1/4W	
R234	0684-6821	R: FXD COMP 6800 OHMS 10% 1/4W	
R235	0684-8231	R: FXD COMP 82K OHMS 10% 1/4W	
R236	0684-1021	R: FXD COMP 1000 OHMS 10% 1/4W	
R237	0684-1541	R: FXD COMP 150K OHMS 10% 1/4W	
R238	0757-0370	R: FXD MET FLM 49.9K OHMS 1% 1/2W	
R239 AND R240		NOT ASSIGNED	
R241	0684-4721	R: FXD COMP 4700 OHMS 10% 1/4W	
R242	0761-0006	R: FXD MET OX 10K OHMS 5% 1W	
R243	0758-0020	R: FXD MET FLM 22K OHMS 5% 1/2W	
R244 THRU R250		NOT ASSIGNED	
R251	0684-1031	R: FXD COMP 10K OHMS 10% 1/4W	
R252	2100-0093	R: VAR COMP 20K OHMS 20% LIN 1/5W	
R253	0758-0019	R: FXD MET OX 18K OHMS 5% 1/2W	
R254 THRU R260		NOT ASSIGNED	
R261	0727-0140	R: FXD DEPC 6K OHMS 1% 1/2W	
R262	0727-0157	R: FXD DEPC 10K OHMS 1% 1/2W	
R263	0727-0173	R: FXD DEPC 20K OHMS 1% 1/2W	
R264	0727-0115	R: FXD DEPC 2K OHMS 1% 1/2W	
R265	0727-0105	R: FXD DEPC 1200 OHMS 1% 1/2W	
R266	0727-0072	R: FXD DEPC 403 OHMS 1% 1/2W	
R267	0727-0054	R: FXD DEPC 200 OHMS 1% 1/2W	
R268	0721-0008	R: FXD DEPC 195 OHMS 1% 1/8W	
R269 AND R270		NOT ASSIGNED	
R271	0757-0416	R: FXD MET FLM 511 OHMS 1% 1/8W	
R272		NSR (P/O A12)	
R273	2100-1559	R: VAR WW 5K OHMS 5% 1-1/2W 10-TURN	
R274		NSR (P/O A12)	
R275	0757-0427	R: FXD MET FLM 1500 OHMS 1% 1/8W	
R276	0757-0844	R: FXD MET FLM 16.2K OHMS 1% 1/2W	
R277	0757-0435	R: FXD MET FLM 3920 OHMS 1% 1/8W	
R278 THRU R280		NOT ASSIGNED	
R281	0684-8231	R: FXD COMP 82K OHMS 10% 1/4W	
R282	0684-4721	R: FXD COMP 4700 OHMS 10% 1/4W	

# See introduction to this section

Table 6-1. Reference Designation Index (Cont'd)

Reference Designation	Part No.	Description #	Note
R283 THRU R300		NOT ASSIGNED	
R301	0684-8231	R: FXD COMP 82K OHMS 10% 1/4W	
R302	0812-0051	R: FXD WW 15K OHMS 3% 3W	
R303	0684-1811	R: FXD COMP 180 OHMS 10% 1/4W	
R304	0684-5621	R: FXD COMP 5600 OHMS 10% 1/4W	
R305	0684-2231	R: FXD COMP 22K OHMS 10% 1/4W	
R306 THRU R310		NOT ASSIGNED	
R311	0811-1335	R: FXD WW 11K OHMS 3% 3W	
R312	0684-4721	R: FXD COMP 4700 OHMS 10% 1/4W	
R313	0684-2241	R: FXD COMP 220K OHMS 10% 1/4W	
R314 THRU R320		NOT ASSIGNED	
R321	0683-5125	R: FXD COMP 5100 OHMS 5% 1/4W	
R322	0684-1041	R: FXD COMP 100K OHMS 10% 1/4W	
R323	0683-2025	R: FXD COMP 2000 OHMS 5% 1/4W	
R324	0683-5125	R: FXD COMP 5100 OHMS 5% 1/4W	
R325	0684-4731	R: FXD COMP 47K OHMS 10% 1/4W	
R326 THRU R330		NOT ASSIGNED	
R331	0684-1011	R: FXD COMP 100 OHMS 10% 1/4W	
R332	0683-5105	R: FXD COMP 51 OHMS 5% 1/4W	
R333 AND R334		NOT ASSIGNED	
R335	0683-1035	R: FXD COMP 10K OHMS 5% 1/4W	
R336	0683-2425	R: FXD COMP 2400 OHMS 5% 1/4W FACTORY SELECTED COMP: TYPICAL VALUE GIVEN	
R337 THRU R400		NOT ASSIGNED	
R401	0684-5621	R: FXD COMP 5600 OHMS 10% 1/4W	
R402	0684-3901	R: FXD COMP 39 OHMS 10% 1/4W	
R403	0684-1011	R: FXD COMP 100 OHMS 10% 1/4W	
R404	0684-1011	R: FXD COMP 100 OHMS 10% 1/4W	
R405	0687-1801	R: FXD COMP 18 OHMS 10% 1/2W	
R406	0699-0001	R: FXD COMP 2.7 OHMS 10% 1/2W	
R407 THRU R409		NOT ASSIGNED	
R410		NSR (P/O A11)	
R411	0687-1811	R: FXD COMP 180 OHMS 10% 1/2W	
R412		NSR (P/O A11)	
R413	0687-1811	R: FXD COMP 180 OHMS 10% 1/2W	
R414 THRU R421		NOT ASSIGNED	

# See introduction to this section

Table 6-1. Reference Designation Index (Cont'd)

Reference Designation	Part No.	Description #	Note
R422	0684-1061	R: FXD COMP 10 MEGOHMS 10% 1/4W	
R423	0684-1061	R: FXD COMP 10 MEGOHMS 10% 1/4W	
R424 THRU			
R440		NOT ASSIGNED	
R441	0677-0005	R: FXD PELLET 35 OHMS 5% 1/8W	
R442	0684-1051	R: FXD COMP 1 MEGOHM 10% 1/4W	
R443 THRU			
R500		NOT ASSIGNED	
R501	0683-1045	R: FXD COMP 100K OHMS 5% 1/4W	
R502	0684-1011	R: FXD COMP 100 OHMS 10% 1/4W	
R503	2100-0191	R: VAR COMP 250K OHM 20% LIN 1/4W (HORIZ GAIN)	
R504	0683-1035	R: FXD COMP 10K OHMS 5% 1/4W	
R505	0686-5135	R: FXD COMP 51K OHMS 5% 1/2W	
R506	0683-8225	R: FXD COMP 8200 OHMS 5% 1/4W	
R507	0683-1035	R: FXD COMP 10K OHMS 5% 1/4W	
R508	0687-1541	R: FXD COMP 150K OHMS 10% 1/2W	
R509 AND			
R510		NOT ASSIGNED	
R511	0684-4721	R: FXD COMP 4700 OHMS 10% 1/4W	
R512	2100-0835	R: VAR COMP 5K OHMS 20% LIN 1/4W (HORIZ POSITION)	
R513	0684-4721	R: FXD COMP 4700 OHMS 10% 1/4W	
R514	0684-1011	R: FXD COMP 100 OHMS 10% 1/4W	
R515	0683-1045	R: FXD COMP 100K OHMS 5% 1/4W	
R516 THRU			
R524		NOT ASSIGNED	
R525	2100-0820	R: VAR WW 50K OHMS 3% LIN 2W (VERT POSITION)	
R526	0757-0469	R: FXD MET FLM 150K OHMS 1% 1/8W	
R527		NSR (P/O A12)	
R528	0757-0461	R: FXD MET FLM 68.1K OHMS 1% 1/8W	
R529	0757-0427	R: FXD MET FLM 1500 OHMS 1% 1/8W	
R530	0757-0465	R: FXD MET FLM 100K OHMS 1% 1/8W	
R531 THRU			
R533		NOT ASSIGNED	
R534	0684-1001	R: FXD COMP 10 OHMS 10% 1/4W	
R535	0757-0370	R: FXD MET FLM 49.9K OHMS 1% 1/2W	
R536	0757-0128	R: FXD MET FLM 200K OHMS 2% 1/2W	
R537	0757-0128	R: FXD MET FLM 200K OHMS 2% 1/2W	
R538	0757-0370	R: FXD MET FLM 49.9K OHMS 1% 1/2W	
R539 THRU			
R544		NOT ASSIGNED	
R545	0727-1012	R: FXD DEPC 12.7K OHMS 1% 1/2W	
R546	0727-1014	R: FXD DEPC 4990 OHMS 1% 1/2W	
R547	0757-1010	R: FXD DEPC 2490 OHMS 1% 1/2W	
R548	0727-1017	R: FXD DEPC 1240 OHMS 1% 1/2W	
R549	0727-1016	R: FXD DPEC 499 OHMS 1% 1/2W	

# See introduction to this section

Table 6-1. Reference Designation Index (Cont'd)

Reference Designation	Part No.	Description #	Note
R550	0727-1011	R: FXD DEPC 243 OHMS 1% 1/2W	
R551	0727-1015	R: FXD DEPC 124 OHMS 1% 1/2W	
R552 THRU			
R560		NOT ASSIGNED	
R561	0727-0196	R: FXD DEPC 52.6K OHMS 1% 1/2W	
R562	0727-0196	R: FXD DEPC 52.6K OHMS 1% 1/2W	
R563	0727-0894	R: FXD DEPC 28.4K OHMS 1% 1/2W	
R564	0727-0208	R: FXD DEPC 100K OHMS 1% 1/2W	
R565	0727-0894	R: FXD DEPC 28.4K OHMS 1% 1/2W	
R566	0727-0208	R: FXD DEPC 100K OHMS 1% 1/2W	
R567 THRU			
R570		NOT ASSIGNED	
R571	0727-1013	R: FXD MET FLM 165K OHMS 1% 1/4W	
R572	0684-1011	R: FXD COMP 100 OHMS 10% 1/4W	
R573	0684-1541	R: FXD COMP 150K OHMS 10% 1/4W	
R574	2100-0080	R: VAR COMP 1 MEGOHM 30% LIN 2W (VERT CAL)	
R575	2100-0924	R: VAR COMP 5K OHMS 20% LIN 1/4W (VERNIER)	
R576	0684-1011	R: FXD COMP 100 OHMS 10% 1/4W	
R577	0727-1013	R: FXD MET FLM 165K OHMS 1% 1/4W	
R578 THRU			
R580		NOT ASSIGNED	
R581	0727-0185	R: FXD DEPC 29.9K OHMS 1% 1/2W	
R582	0727-0185	R: FXD DEPC 29.9K OHMS 1% 1/2W	
R583	0727-0185	R: FXD DEPC 29.9K OHMS 1% 1/2W	
R584	0757-0185	R: FXD DEPC 29.9K OHMS 1% 1/2W	
R585	0687-4731	R: FXD COMP 47K OHMS 10% 1/2W	
R586 THRU			
R590		NOT ASSIGNED	
R591	0727-0281	R: FXD DEPC 1.39 MEGOHMS 1% 1/2W	
R592	0683-2745	R: FXD COMP 270K OHMS 5% 1/4W	
R593	0727-0261	R: FXD DEPC 900K OHMS 1% 1/2W	
R594	0683-1235	R: FXD COMP 12K OHMS 5% 1/4W	
R595 THRU			
R597		NOT ASSIGNED	
R598	2100-1562	R: VAR DUAL COMP 5 MEGOHMS 20% 1/4W	
R599 AND			
R600		NOT ASSIGNED	
R601	0683-1135	R: FXD COMP 11K OHMS 5% 1/4W	
R602	2100-0090	R: VAR COMP 2K OHMS 30% LIN 1/3W	
R603	0683-1235	R: FXD COMP 12K OHMS 5% 1/4W	
R604	0816-0011	R: FXD WW 1K OHM 5% 10W	
R605	0758-0012	R: FXD MET OX 12K OHMS 5% 1/2W	
R606	0767-0021	R: FXD MET OX 2700 OHMS 5% 3W	
R607	0684-1001	R: FXD COMP 10 OHMS 10% 1/4W	
R608	0811-1000	R: FXD WW 68 OHMS 3% 3W	
R609	0683-1225	R: FXD COMP 1200 OHMS 5% 1/4W	

# See introduction to this section

Table 6-1. Reference Designation Index (Cont'd)

Reference Designation	Part No.	Description #	Note
S202		NSR (P/O A10)	
S203		NSR (P/O A13)	
S204 THRU			
S300		NOT ASSIGNED	
S301		NSR (P/O A9)	
S302 THRU			
S500		NOT ASSIGNED	
S501	3101-0032	SWITCH: SLIDE 4 PDT (DUAL)	
S502		NSR (P/O A8)	
T101	01415-66002	ASSY: TRANSFORMER	
T102 THRU			
T400		NOT ASSIGNED	
T401	01415-66001	ASSY: TRANSFORMER	
V401	5080-0434	ELECTRON TUBE: 7586 (AGED AND SELECTED AT FACTORY)	
V402 THRU			
V500		NOT ASSIGNED	
V501	1932-0027	ELECTRON TUBE: 12AT7	
V502	1932-0027	ELECTRON TUBE: 12AT7	
V503	5080-0434	ELECTRON TUBE: 7586 (AGED AND SELECTED AT FACTORY)	
XT101	1200-0053	SOCKET: TUBE 7 PIN	
XT102	THRU		
XT400		NOT ASSIGNED	
XT401	1200-0083	SOCKET: TUBE 7 PIN	
XV401	1200-0086	SOCKET: TUBE 5 PIN NUVISTOR	
XV402 THRU			
XV500		NOT ASSIGNED	
XV501	1200-0062	SOCKET: TUBE 9 PIN	
XV502	1200-0062	SOCKET: TUBE 9 PIN	
MISCELLANEOUS			
	0370-0025	KNOB: BLACK (VERT POSITION)	
	0370-0088	KNOB: BLACK (LOCK)	
	0370-0112	KNOB: BLACK (MAGNIFIER)	
	0370-0113	KNOB: BLACK (REFL COEFFICIENT AND SWEEP)	
	0370-0114	KNOB: RED (VERNIER AND MANUAL SCAN)	
	0370-0151	KNOB: BLACK (F and BW)	
	0370-0156	KNOB: BLACK <sup>0</sup> DOUBLE ARROW (CM/LINE CM/DISPLAY)	
	0370-0158	KNOB: BLACK (HORIZ POS)	
	1250-0239	CONNECTOR: TYPE GR 874-EL	
	1250-0240	CONNECTOR: TYPE GR 874-QNJA, TYPE N ADAPTER	
	1250-0780	CONNECTOR: TYPE N TO BNC ADAPTER	
	1390-0035	LATCH: FASTENER	
	5000-0401	SPRING: GROUND	
	6960-0008	BUTTON: PLUG 1-1/4 IN. DIA	
	6960-0016	BUTTON: PLUG NYLON	

# See introduction to this section

Table 6-1. Reference Designation Index (Cont'd)

Reference Designation	Part No.	Description #	Note
	01415-00205 01415-05501 01415-05502 01415-21101 01415-21102	PANEL: FRONT COVER: SHIELD CAN CAN: SHIELD COVER: DIODE (USED WITH CR301 and CR302) HEAT SINK (USED WITH Q306)	
	01415-21203 01415-61102 01415-61103	CLAMP: DIODE (USED WITH CR403) HEAT SINK (USED WITH Q211 and Q301) COVER: TRANSISTOR (USED WITH Q304 and Q307)	
	01415-61616 01415-61617 01415-90001	CABLE: MAIN HARNESS CABLE: MANUAL SCAN OVERLAY: 50-OHM IMPEDANCE (1SET)	

# See introduction to this section

Table 6-2. Replaceable Parts

Part No.	Description #	Mfr.	Mfr. Part No.	TQ	RS
0130-0001	C: VAR CER 7-45 PF 500VDCW	hp		1	
0140-0145	C: FXD MICA 22 PF 5% 500VDCW	04062	RDM15C220J	5	
0140-0177	C: FXD MICA 400 PF 1% 300VDCW	04062	RDM15F401F3C	1	
0140-0180	C: FXD MICA 2000 PF 2% 300VDCW	04062	RDM19F202G3C	1	
0140-0190	C: FXD MICA 39 PF 5% 300VDCW	04062	RDM15E390J3C	2	
0140-0200	C: FXD MICA 390 PF 5% 300VDCW	04062	RDM15F391J3C	1	
0140-0202	C: FXD MICA 15 PF 5% 500VDCW	hp		3	
0140-0206	C: FXD MICA 270 PF 5% 500VDCW	04062	RDM15F271J5C	1	
0140-0208	C: FXD MICA 680 PF 5%	hp		1	
0140-0215	C: FXD MICA 80 PF 2% 300VDCW	04062	RDM15E800G3C	1	
0140-0218	C: FXD MICA 160 PF 2% 300VDCW	04062	RDM15F161G3C	2	
0140-0220	C: FXD MICA 200 PF 1% 300VDCW	04062	RDM15F201F3C	1	
0140-0225	C: FXD MICA 300 PF 1% 300VDCW	04062	RDM15F301F3C	1	
0140-0231	C: FXD MICA 440 PF 1% 300VDCW	hp		1	
0140-0233	C: FXD MICA 480 PF 1% 300VDCW	hp		1	
0150-0012	C: FXD CER 0.01 $\mu$ f 20% 1000VDCW	56289	29C214A3	5	
0150-0014	C: FXD CER 5000 PF MIN 500VDCW	04222	BCD-D1-4-5KPFQ	2	
0150-0035	C: FXD CER 20 PF 10% 600VDCW	71590	DD200	2	
0150-0052	C: FXD CER 0.05 $\mu$ f 20% 400VDCW	56289	33C17A	1	
0150-0069	C: FXD CER 1000 PF 500VDCW	72982	801010X5G0102Z	3	
0150-0087	C: FXD CER 62 PF 10% 500VDCW	91418	SM-62-N1500 10%	2	
0150-0121	C: FXD CER 0.1 $\mu$ f +80 -20% 50VDCW	56289	5CMOA	5	
0160-0127	C: FXD CER 1 $\mu$ f 20% 25VDCW	56289	5C13	2	
0160-0168	C: FXD MY 0.1 $\mu$ f 10% 200VDCW	hp		1	
0160-0839	C: FXD MICA 110 PF 1%	hp		1	
0160-0840	C: FXD MICA 834 PF 1% 100VDCW	hp		1	
0160-0841	C: FXD MICA 1740 PF 1%	hp		1	
0160-2056	C: FXD MY 0.22 $\mu$ f 20% 200VDCW	56289	224P22402	1	
0160-2167	C: FXD MICA 380 PF 1% 300VDCW	hp		1	
0180-0049	C: FXD ELECT 20 $\mu$ f 50VDCW	56289	D33909	1	
0180-0058	C: FXD ELECT 50 $\mu$ f +100 -10% 25VDCW	56289	D28110	1	
0180-0059	C: FXD ELECT 10 $\mu$ f +100 -10% 25VDCW	56289	30D106G025BB4	1	
0180-0076	C: FXD ELECT 20 $\mu$ f 25VDCW	56289	40D 181 A2	2	
0180-0101	C: FXD ELECT TA 1.8 $\mu$ f 10% 35VDCW	56289	150D185X9035B2	2	
0180-1706	C: FXD ELECT TA 100 $\mu$ f 20% 25VDCW	56289	109D107X9025F2	1	
0370-0025	KNOB: BLACK (VERT POSITION)	hp		1	
0370-0088	KNOB: BLACK (LOCK)	hp		1	
0370-0112	KNOB: BLACK (MAGNIFIER)	hp		1	
0370-0113	KNOB: BLACK (REFL COEFFICIENT AND SWEEP)	hp		2	
0370-0114	KNOB: RED (VERNIER AND MANUAL SCAN)	hp		2	
0370-0151	KNOB: BLACK (F <sub>o</sub> and BW)	hp		2	
0370-0156	KNOB: BLACK <sup>o</sup> DOUBLE ARROW (CM/LINE-CM/DISPLAY)	hp		1	
0370-0158	KNOB: BLACK (HORIZ POS)	hp		1	
0677-0004	R: FXD PELLET 49 OHMS 1% 1/8W	hp		1	
0677-0005	R: FXD PELLET 35 OHMS 5% 1/8W	hp		1	
0683-1025	R: FXD COMP 1K OHM 5% 1/4W	01121	CB 1025	1	
0683-1035	R: FXD COMP 10K OHMS 5% 1/4W	01121	CB 1035	3	

# See introduction to this section

Table 6-2. Replaceable Parts (Cont'd)

Part No.	Description #	Mfr.	Mfr. Part No.	TQ	RS
0683-1045	R: FXD COMP 100K OHMS 5% 1/4W	01121	CB 1045	2	
0683-1135	R: FXD COMP 11K OHMS 5% 1/4W	01121	CB 1135	2	
0683-1225	R: FXD COMP 1200 OHMS 5% 1/4W	01121	CB 1225	2	
0683-1235	R: FXD COMP 12K OHMS 5% 1/4W	01121	CB 1235	2	
0683-1525	R: FXD COMP 1500 OHMS 5% 1/4W	01121	CB 1525	1	
0683-2025	R: FXD COMP 2000 OHMS 5% 1/4W	01121	CB 2025	1	
0683-2035	R: FXD COMP 20K OHMS 5% 1/4W	01121	CB 2035	1	
0683-2425	R: FXD COMP 2400 OHMS 5% 1/4W	01121	CB 2425	1	
0683-2715	R: FXD COMP 270 OHMS 5% 1/4W	01121	CB 2715	1	
0683-2745	R: FXD COMP 270K OHMS 5% 1/4W	01121	CB 2745	1	
0683-3915	R: FXD COMP 390 OHMS 5% 1/4W	01121	CB 3915	1	
0683-5105	R: FXD COMP 51 OHMS 5% 1/4W	01121	CB 5105	2	
0683-5125	R: FXD COMP 5100 OHMS 5% 1/4W	01121	CB 5125	2	
0683-5145	R: FXD COMP 510K OHMS 5% 1/4W	01121	CB 5145	1	
0683-5615	R: FXD COMP 560 OHMS 5% 1/4W	01121	CB 5615	1	
0683-6815	R: FXD COMP 680 OHMS 5% 1/4W	01121	CB 6851	1	
0683-8205	R: FXD COMP 82 OHMS 5% 1/4W	01121	CB 8205	1	
0683-8225	R: FXD COMP 8200 OHMS 5% 1/4W	01121	CB 8225	1	
0684-1001	R: FXD COMP 10 OHMS 10% 1/4W	01121	CB 1001	3	
0684-1011	R: FXD COMP 100 OHMS 10% 1/4W	01121	CB 1011	8	
0684-1021	R: FXD COMP 1000 OHMS 10% 1/4W	01121	CB 1021	3	
0684-1031	R: FXD COMP 10K OHMS 10% 1/4W	01121	CB 1031	2	
0684-1041	R: FXD COMP 100K OHMS 10% 1/4W	01121	CB 1041	1	
0684-1051	R: FXD COMP 1 MEGOHM 1% 1/4W	01121	CB 1051	1	
0684-1061	R: FXD COMP 10 MEGOHMS 10% 1/4W	01121	CB 1061	2	
0684-1211	R: FXD COMP 120 OHMS 10% 1/4W	01121	CB 1211	1	
0684-1531	R: FXD COMP 15K OHMS 10% 1/4W	01121	CB 1531	1	
0684-1541	R: FXD COMP 150K OHMS 10% 1/4W	01121	CB 1541	2	
0684-1811	R: FXD COMP 180 OHMS 10% 1/4W	01121	CB 1811	1	
0684-2201	R: FXD COMP 22 OHMS 10% 1/4W	01121	CB 2201	1	
0684-2221	R: FXD COMP 2200 OHMS 10% 1/4W	01121	CB 2221	3	
0684-2231	R: FXD COMP 22K OHMS 10% 1/4W	01121	CB 2231	3	
0684-2241	R: FXD COMP 220K OHMS 10% 1/4W	01121	CB 2241	2	
0684-3901	R: FXD COMP 39 OHMS 10% 1/4W	01121	CB 3901	1	
0684-3921	R: FXD COMP 3900 OHMS 10% 1/4W	01121	CB 3921	1	
0684-4721	R: FXD COMP 4700 OHMS 10% 1/4W	01121	CB 4721	6	
0684-4731	R: FXD COMP 47K OHMS 10% 1/4W	01121	CB 4731	1	
0684-5621	R: FXD COMP 5600 OHMS 10% 1/4W	01121	CB 5621	2	
0684-6821	R: FXD COMP 6800 OHMS 10% 1/4W	01121	CB 6821	5	
0684-6831	R: FXD COMP 68K OHMS 10% 1/4W	01121	CB 6831	1	
0684-8221	R: FXD COMP 8200 OHMS 10% 1/4W	01121	CB 8221	2	
0684-8231	R: FXD COMP 82K OHMS 10% 1/4W	01121	CB 8231	4	
0686-1635	R: FXD COMP 16K OHMS 5% 1/2W	01121	EB 1635	1	
0686-3055	R: FXD COMP 3 MEGOHMS 5% 1/2W	01121	EB 3055	1	
0686-5135	R: FXD COMP 51K OHMS 5% 1/2W	01121	EB 5135	2	
0687-1541	R: FXD COMP 150K OHMS 10% 1/2W	01121	EB 1541	1	

# See introduction to this section

Table 6-2. Replaceable Parts (Cont'd)

Part No.	Description #	Mfr.	Mfr. Part No.	TQ	RS
0687-1801	R: FXD COMP 18 OHMS 10% 1/2W	01121	EB 1801	1	
0687-1811	R: FXD COMP 180 OHMS 10% 1/2W	01121	EB 1811	2	
0687-4731	R: FXD COMP 47K OHMS 10% 1/2W	01121	EB 4731	1	
0699-0001	R: FXD COMP 2.7 OHMS 10% 1/2W	01121	EB 27G1	1	
0721-0008	R: FXD DEPC 195 OHMS 1% 1/8W	hp		1	
0727-0054	R: FXD DEPC 200 OHMS 1% 1/2W	hp		1	
0727-0072	R: FXD DEPC 403 OHMS 1% 1/2W	hp		1	
0727-0105	R: FXD DEPC 1200 OHMS 1% 1/2W	hp		1	
0727-0115	R: FXD DEPC 2000 OHMS 1% 1/2W	hp		1	
0727-0140	R: FXD DEPC 6000 OHMS 1% 1/2W	hp		1	
0727-0157	R: FXD DEPC 10K OHMS 1% 1/2W	hp		1	
0727-0173	R: FXD DEPC 20K OHMS 1% 1/2W	hp		1	
0727-0185	R: FXD DEPC 29.9K OHMS 1% 1/2W	hp		4	
0727-0196	R: FXD DEPC 52.6K OHMS 1% 1/2W	hp		2	
0727-0208	R: FXD DEPC 100K OHMS 1% 1/2W	hp		2	
0727-0261	R: FXD DEPC 900K OHMS 1% 1/2W	hp		1	
0727-0281	R: FXD DEPC 1.39 MEGOHMS 1% 1/2W	hp		1	
0727-0894	R: FXD DEPC 28.4K OHMS 1% 1/2W	hp		2	
0727-1010	R: FXD CAR FLM 2490 OHMS 1% 1/2W	hp		1	
0727-1011	R: FXD CAR FLM 243 OHMS 1% 1/2W	hp		1	
0727-1012	R: FXD CAR FLM 12.7K OHMS 1% 1/2W	hp		1	
0727-1013	R: FXD CAR FLM 165K OHMS 1% 1/2W	hp		2	
0727-1014	R: FXD CAR FLM 4990 OHMS 1% 1/2W	hp		1	
0727-1015	R: FXD CAR FLM 124 OHMS 1% 1/2W	hp		1	
0727-1016	R: FXD CAR FLM 499 OHMS 1% 1/2W	hp		1	
0727-1017	R: FXD CAR FLM 1240 OHMS 1% 1/2W	hp		1	
0757-0128	R: FXI MET FLM 200K OHMS 2% 1/2W	hp		1	
0757-0370	R: FXD MET FLM 49.4K OHMS 1% 1/2W	hp		3	
0757-0431	R: FXD METFLM 392 OHMS 1% 1/8W	hp		1	
0757-0414	R: FXD MET FLM 432 OHMS 1% 1/8W	hp		1	
0757-0416	R: FXD MET FLM 511 OHMS 1% 1/8W	hp		1	
0757-0426	R: FXD MET FLM 1300 OHMS 1% 1/8W	hp		1	
0757-0427	R: FXD MET FLM 1500 OHMS 1% 1/8W	hp		2	
0757-0435	R: FXD MET FLM 3920 OHMS 1% 1/8W	hp		1	
0757-0442	R: FXD MET FLM 10K OHMS 1% 1/8W	hp		1	
0757-0452	R: FXD MET FLM 27.4K OHMS 1% 1/8W	hp		1	
0757-0461	R: FXD MET FLM 68.1K OHMS 1% 1/8W	hp		1	
0757-0465	R: FXD MET FLM 100K OHMS 1% 1/8W	hp		1	
0757-0469	R: FXD MET FLM 150K OHMS 1% 1/8W	hp		1	
0757-0844	R: FXD MET FLM 16.2K OHMS 1% 1/2W	hp		1	
0758-0012	R: FXD MET FLM 12K OHMS 5% 1/2W	hp		1	
0758-0019	R: FXD MET FLM 18K OHMS 5% 1/2W	hp		1	
0758-0020	R: FXD MET FLM 22K OHMS 5% 1/2W	hp		1	
0761-0006	R: FXD MET FLM 10K OHMS 5% 1W	hp		1	
0761-0014	R: FXD MET FLM 180 OHMS 5% 1W	hp		1	
0767-0021	R: FXD MET FLM 2700 OHMS 5% 3W	hp		1	

# See introduction to this section

Table 6-2. Replaceable Parts (Cont'd)

Part No.	Description #	Mfr.	Mfr. Part No.	TQ	RS
0811-1000	R: FXD WW 68 OHMS 3% 3W	hp		1	
0811-1335	R: FXD WW 11K OHMS 3% 3W	hp		1	
0812-0051	R: FXD WW 15K OHMS 3% 3W	hp		1	
0816-0011	R: FXD WW 1000 OHMS 10% 10W	hp		1	
1200-0053	SOCKET: TUBE 7 PIN MINAT	71785	111-51-11-069	1	
1200-0062	SOCKET: TUBE 9 PIN MINAT	71785	121-51-11-060	2	
1200-0083	SOCKET: TUBE 7 PIN MINAT	91662	04-730-02	1	
1200-0086	SOCKET: NUVISTOR 5 PIN	71785	133-65-11-026	1	
1250-0118	CONNECTOR: BNC	hp		3	
1250-0239	CONNECTOR: TYPE GR 874-EL	24655	874-EL	1	
1250-0240	CONNECTOR: TYPE GR 874-QNJA, TYPE N ADAPTER	24655	874-QNJA	1	
1250-0780	CONNECTOR: TYPE N TO BNC ADAPTER	95712	899-2	1	
1251-0055	CONNECTOR: MALE 24 PIN	hp		2	
1390-0035	LATCH: FASTENER	hp		1	
1850-0040	TRANSISTOR: GE PNP 2N383	94154	2N383	3	
1850-0062	TRANSISTOR: GE PNP	hp		2	
1850-0070	TRANSISTOR: GE PNP 2N1373	01295	2N1373	1	
1850-0096	TRANSISTOR: GE PNP 2N2189	01295	2N2189	2	
1850-0101	TRANSISTOR: GE PNP SPL 2N582	hp		2	
1850-0128	TRANSISTOR: GE PNP 2N398B	02735	34600	1	
1850-0143	TRANSISTOR: GE PNP	hp		1	
1850-0158	TRANSISTOR: GE PNP 2N2635	01295	2N2635	6	
1851-0017	TRANSISTOR: GE NPN 2N1304	01295	2N1304	1	
1851-0024	TRANSISTOR: GE NPN 2N388A	0000T	2B388A	3	
1853-0001	TRANSISTOR: SI PNP	hp		1	
1853-0010	TRANSISTOR: SI PNP			2	
1854-0003	TRANSISTOR: SI NPN	hp		4	
1854-0005	TRANSISTOR: SI NPN 2N708	07263	2N708	3	
1854-0013	TRANSISTOR: SI NPN 2N2218A	04713	2N2218A	1	
1854-0022	TRANSISTOR: SI NPN 2N918	hp		1	
1854-0033	TRANSISTOR: SI NPN 2N3391	03508	2N3391	2	
1854-0054	TRANSISTOR: SI NPN	hp		2	
1901-0040	DIODE: SI	hp		3	
1901-0092	DIODE: SI STEP RECOVERY	hp		1	
1901-0115	DIODE: SI	hp		1	
1901-0155	DIODE: SI	hp		1	
1901-0163	DIODE: SI SAMPLING	hp		2	
1901-0179	DIODE: SI	hp		1	
1902-0055	DIODE: AVALANCHE 14.7V	hp		3	
1903-0005	DIODE: SI FOUR LAYER	hp		1	
1910-0016	DIODE: GE	hp		5	
1912-0007	DIODE: GE TUNNEL 1N3714	03508	1N3714 Special	2	
1912-0008	DIODE: GE TUNNEL	hp		1	
1912-0012	DIODE: GE TUNNEL	hp		1	
1932-0027	ELECTRON TUBE: 12AT7	13396	12AT7	2	
2100-0080	R: VAR COMP 1 MEGOHM 30% LIN 2W	hp		1	

# See introduction to this section

Table 6-2. Replaceable Parts (Cont'd)

Part No.	Description #	Mfr.	Mfr. Part No.	TQ	RS
2100-0090	R: VAR COMP 2000 OHMS 30% LIN 1/3W	hp		1	
2100-0093	R: VAR COMP 20K OHMS 20% LIN 1/5W	hp		1	
2100-0118	R: VAR COMP 100 OHMS 20% LIN 3/10W	hp		1	
2100-0191	R: VAR COMP 250K OHMS 20% LIN 1/4W	hp		1	
2100-0397	R: VAR COMP 20K OHMS 20% 1/4W	hp		1	
2100-0421	R: VAR COMP 5K OHMS 20% LIN 3/10W	hp		2	
2100-0797	R: VAR COMP 1K 5K OHMS 20% LIN 1/4W	hp		1	
2100-0820	R: VAR WW 50K OHMS 3% LIN 2W	hp		1	
2100-0835	R: VAR COMP 5K OHMS 20% LIN 1/4W	hp		1	
2100-0836	R: VAR COMP 100K OHMS 20% LIN 1/4W	hp		1	
2100-0923	R: VAR COMP 150K 2K 2K OHMS 20% 1/4W	hp		1	
2100-0924	R: VAR COMP 5K OHMS 20% LIN 1/2W	hp		1	
2100-1559	R: VAR WW 5K OHMS 5% 1-1/2W	hp		1	
2100-1562	R: VAR DUAL COMP 5 MEGOHMS 20% 1/4W	hp		1	
3101-0032	SWITCH: SLIDE 4 PDT	42190	6613 M Special	1	
5000-0401	SPRING: GROUND	hp		1	
5080-0434	ELECTRON TUBE: 7586	hp		2	
6960-0008	BUTTON: PLUG 1-1/4 in. dia.			1	
6960-0016	BUTTON: PLUG NYLON	02768	207-080-501-01-0101	1	
9140-0075	COIL: RF 270 $\mu$ h 10%	hp		1	
9140-0095	COIL: RF FXD 0.27 $\mu$ h 10%	99800	1537 Series	2	
9140-0137	COIL: RF FXD 1000 $\mu$ h	hp		3	
9170-0029	INDUCTOR: FERRITE BEAD	02114	56-590-654A	12	
9170-0031	INDUCTOR: FERRITE BEAD	72656	8-303H	4	
9190-0007	DELAY LINE: 1000 OHMS 0.14 $\mu$ SEC	hp		1	
00188-68201	ASSY: CAPACITOR	hp		2	
01415-00205	PANEL: FRONT	hp		1	
01415-05501	COVER: SHIELD CAN	hp		1	
01415-05502	CAN: SHIELD	hp		1	
01415-21101	COVER: DIODE	hp		1	
01415-21102	HEAT SINK	hp		1	
01415-21203	CLAMP: DIODE	hp		1	
01415-61102	HEAT SINK	hp		1	
01415-61103	COVER: TRANSISTOR	hp		2	
01415-61616	CABLE: MAIN HARNESS	hp		1	
01415-61617	CABLE: MANUAL SCAN	hp		1	
01415-61901	ASSY: SWITCH (VERT SENS)	hp		1	
01415-61902	ASSY: SWITCH (TIME SCALE)	hp		1	
01415-61903	ASSY: SWITCH (TIME SCALE MAGNIFIER)	hp		1	
01415-61904	ASSY: SWITCH (SWEEP)	hp		1	
01415-66001	ASSY: TRANSFORMER	hp		1	
01415-66002	ASSY: TRANSFORMER	hp		1	
01415-66003	ASSY: ETCHED CIRCUIT (AMPLIFIER)	hp		1	
01415-66506	ASSY: ETCHED CIRCUIT (INPUT AMPLIFIER)	hp		1	
01415-66510	ASSY: ETCHED CIRCUIT (PULSE GENERATOR)	hp		1	
01415-66512	ASSY: ETCHED CIRCUIT (SAMPLER)	hp		1	
01415-66513	ASSY: ETCHED CIRCUIT (TIME BASE)	hp		1	
01415-66514	ASSY: ETCHED CIRCUIT (TRIMMER)	hp		1	
01415-66515	ASSY: ETCHED CIRCUIT (POWER SUPPLY)	hp		1	
01415-90001	OVERLAY: 50 OHM IMPEDANCE (1SET)	hp		1	

# See introduction to this section

Table 6-3. Code List of Manufacturers

The following code numbers are from the Federal Supply Code for Manufacturers Cataloging Handbooks H4-1 (Name to Code) and H4-2 (Code to Name) and their latest supplements. The date of revision and the date of the supplements used appear at the bottom of each page. Alphabetical codes have been arbitrarily assigned to suppliers not appearing in the H4 handbooks. If Manufacturer Code number does not appear in the numerical listing, check additions at the end of the table.

Code No.	Manufacturer	Address	Code No.	Manufacturer	Address	Code No.	Manufacturer	Address	Code No.	Manufacturer	Address
00000	U S A Common	Any supplier of U. S.	07115	Corning Glass Works	Bradford Pa	24655	General Radio Co	West Concord Mass	73293	Hughes Products Division of	Newport Beach Calif
00136	McCoy Electronics	Mount Holly Springs, Pa.	07126	Electronic Components Dept	Pasadena, Calif.	26365	Gries Reproducer Corp	New Rochelle N Y	73445	Ampe ex Electric Co Div of North	Hicksville N Y
00213	Sage Electronics Corp	Rochester, N. Y.	07137	Digitran Co	Minneapolis, Minn.	26462	Grobet File Co of America Inc	Carlstadt N J	73490	American Phillips Co Inc	Hamden Conn
00334	Humidat Co	Colton Calif.	07138	Transistor Electronics Corp.	Westinghouse Electric Corp	26992	Hamilton Watch Co	Lancaster Pa.	73506	Barling Semiconductor Corp	Hartford Conn
00335	Westrex Corp	New York, N Y	07149	Westinghouse Electric Corp	Elmira N Y	28480	Hewlett-Packard Co	Palo Alto Calif	73582	George K Garrett Co Inc	Philadelphia Pa
00373	Garlock Packing Co., Electronic Products Div	Camden, N J	07233	Filmohm Corp	New York, N Y	31713	G E Receiving Tube Dept	Owensboro Ky	73734	Federal Screw Prod Co	Chicago Ill
00566	Aerovox Corp	New Bedford, Mass	07261	Cinch-Graphix Co	City of Industry Calif.	35434	Lectrohm Inc	Chicago Ill	73743	Fischer Special Mig Co.	Cincinnati Ohio
00779	Amp, Inc.	Harrisburg, Pa.	07263	Anvet Corp.	Los Angeles Calif.	36196	Stanwyck Corp	Hawkesbury, Ontario, Canada	73793	The General Industries Co	Elyria Ohio
00781	Aircraft Radio Corp.	Boonton, N. J.	07263	Fairchild Semiconductor Corp.	Mountain View, Calif.	37942	P R Mallory & Co., Inc	Indianapolis Ind	73846	Goshen Stamping & Tool Co	Goshen Ind
00815	Northern Engineering Laboratories, Inc	Burlington Wis.	07322	Minnesota Rubber Co.	Minneapolis, Minn.	39543	Mechanical Industries Prod. Co	Akron, Ohio	73899	JFD Electronics Corp	Brooklyn N Y
00853	Sangamo Electric Company Ordifl Division (Capacitors)	Marion, Ill.	07387	The Birtcher Corp	Chicago Ill.	40920	Miniature Precision Bearings Inc	Keene N H	73905	Jennings Radio Mig Co	San Jose Calif
00866	Goe Engineering Co	Los Angeles, Calif.	07700	Technical Wire Products	Springfield, N J	42190	Muter Co	Chicago Ill.	74276	Signalite Inc	Winchester Mass
00891	Carl E Holmes Corp	Los Angeles, Calif	07910	Continental Device Corp.	Hawthorne Calif.	43990	C A. Norgren Co	Englewood Colo	74455	J H Winns and Sons	Chicago Ill
01121	Allen Bradley Co	Milwaukee, Wis.	07933	Rheem Semiconductor Corp	Mountain View Calif	44655	Ohmite Mig Co	Skokie, Ill.	74861	Industrial Condenser Corp	Chicago Ill
01255	Liton Industries, Inc.	Beverly Hills, Calif	07966	Shockey Sem Conductor Laboratories	Palo Alto, Calif	4620	Polaroid Corp.	Cambridge Mass	74868	R F Products Division of Ampheno	Danbury Conn
01281	TRW Semiconductors Inc	Laurel, Calif	07980	Boonton Radio Corp.	Boonton, N J	49596	Raytheon Company	Lexington, Mass.	74970	R F Johnson Co	Waseca Minn
01295	Texas Instruments, Inc	Dallas Texas	08145	U S Engineering Co.	Los Angeles, Calif.	52090	Rowan Controller Co	Baltimore, Md.	75042	International Resistance Co	Philadelphia Pa
01349	The Alliance Mig. Co	Alliance, Ohio	08289	Blinn, Delbert Co	Pomona, Calif	63743	Ward Leonard Electric	Mt. Vernon, N. Y.	75173	Jones, Howard B Division	Chicago Ill
01561	Chassi Trak Corp.	Indianapolis, Ind	08598	Burgess Battery Co	Niagara Falls, Ontario, Canada	54294	Shallicross Mig Co	Selma N.C.	75378	James Knights Co	Sandwich, Ill
01589	Pacific Relays, Inc.	Van Nuys, Calif.	08717	Sloan Company	Burbank, Calif.	55026	Simpson Electric Co.	Chicago Ill.	75382	Kuika Electric Corporation	Mt Vernon N Y
01930	Amerock Corp	Rockford, Ill.	08718	Cannon Electric Co Phoenix Div	Phoenix Ariz	55933	Sonotone Corp	Elmsford, N Y	75818	Lenz Electric Mig. Co	Chicago Ill
01961	Futro Engineering Co.	Santa Clara, Calif.	08792	CBS Electronics Semiconductor Operations Div of C B S Inc	Lowell Mass	55938	Sorenson & Co Inc.	So Norwalk Conn.	75915	Littlefuse Inc	Des Plaines Ill
02114	Pulse X Corp of America	Saugerties N Y	08894	Mel Rain	Indianapolis, Ind	56137	Spaulding Fibre Co., Inc.	Tonawanda N Y	76005	Lord Mig Co	Erie Pa
02286	Cole Mig. Co	Palo Alto, Calif.	09025	Mel Rain	Indianapolis, Ind	56289	Sprague Electric Co.	North Adams Mass.	76210	C.W. Marwedel	San Francisco, Calif
02660	Amphenol-Borg Electronics Corp.	Chicago, Ill.	09134	Texas Capacitor Co.	Houston, Texas	59446	Telex Inc	St. Paul, Minn.	76433	Micamold Electronic Mig. Corp	Brooklyn N Y
02735	Radio Corp. of America, Semiconductor and Materials Div.	Somerville, N J	09145	Atom Electronics	Sun Valley, Calif	59730	Thomas & Betts Co.	Elizabeth I., N. J.	76487	James Millen Mig. Co., Inc.	Malden Mass.
02771	Vocaline Co of America, Inc	Old Saybrook, Conn	09250	Electro Assemblies, Inc.	Chicago, Ill.	60741	Tripplett Electrical Inc	Bluffton Ind.	76493	J.W. Miller Co.	Los Angeles Calif
02777	Hokins Engineering Co.	San Fernando, Calif	09569	Mallory Battery Co. of Canada, Ltd	Toronto Ontario Canada	62119	Universal Electric Co	Swissvale, Pa.	76530	Monadnock Mills	San Leandro Calif
03508	G E Semiconductor Products Dept.	Syracuse, N. Y.	09664	The Bristol Co	Waterbury, Conn	63743	Ward-Leonard Electric Co	Gowssio Mich.	76545	Muelier Electric Co.	Cleveland Ohio
03705	Apex Machine & Tool Co	Dayton, Ohio	10214	General Transistor Western Corp.	Los Angeles, Calif.	64959	Western Electric Co., Inc.	New York, N Y	76854	Oak Manufacturing Co	Crystal Lake Ill
03797	Eldem Corp.	El Monte, Calif.	10411	Tri Tal, Inc.	Berkeley, Calif.	65092	Western Instl Div of Daystrom Inc	Newark N J	77068	Bendix Pacific Division of Bendix Corp	No Hollywood Calif
03877	Transiton Electronic Corp.	Wakefield, Mass.	10646	Carborundum Co.	Niagara Falls, N.Y.	66295	Wittek Manufacturing Co.	Chicago 23 Ill	77075	Pacific Metals Co.	San Francisco, Calif
03888	Pyrofilm Resistor Co.	Morristown N J	11236	CTS of Berne Inc	Berne, Ind.	66346	Wollensak Optical Co.	Rochester N Y	77221	Phaoston Instrument and Electronic Co	South Pasadena Calif.
03954	Air Marine Motors, Inc.	Los Angeles, Calif.	11237	Chicago Telephone of California, Inc	So. Pasadena, Calif.	70276	Allen Mig Co.	Hartford, Conn	77250	Phoell Mig Co	Chicago Ill
04009	Arrow, Hart and Hegeman Elect. Co.	Hartford, Conn.	11312	Microwave Electronics Corp.	Palo Alto, Calif	70319	Allmetal Screw Prod Co., Inc.	Garden City N Y	77252	Philadelphia Steel and Wire Corp.	Philadelphia Pa
04013	Taurus Corp	Lambertville, N J	11534	Duncan Electronic, Inc.	Santa Ana, Calif	70485	Atlantic India Rubber Works, Inc	Chicago, Ill.	77342	Potter and Brumfield Div of American Machine and Foundry	Princeton Ind
04062	Elmenco Products Co.	New York, N Y	11711	General Instrument Corporation Semiconductor Division	Newark N J	70563	Amperite Co., Inc	New York, N Y	77630	Radio Condenser Co	Camden, N J
04222	H I Q Division of Aerovox	Myrtle Beach, S C	11717	Imperial Electronic, Inc.	Buena Park, Calif.	70903	Belden Mig. Co	Chicago, Ill.	77638	Radio Receptor Co. Inc	Brooklyn N Y
04298	Elgin National Watch Co., Electronics Division	Burbank, Calif.	11870	Melabs, Inc	Palo Alto, Calif.	70998	Bend Electronic Corp	Cleveland, Ohio	77764	Resistance Products Co	Harrisburg Pa
04354	Precision Paper Tube Co	Chicago, Ill	12136	Philadelphia Handle Co	Camden N J	71002	Brenbach Radio Co.	New York, N.Y.	77969	Shubcraft Corp of Calif	Torrance, Calif
04404	Dymec Division of Hewlett Packard Co	Palo Alto, Calif.	12697	Claroat Mig. Co	Dover N H	71091	Murray Co. of Texas	Quincy, Mass.	78189	Shakerford Division of Illinois Tool Works	Elgin, Ill
04651	Sylvania Electric Prods., Inc Electronic Tube Div.	Mountain View, Calif.	12859	Nippon Electric Co., Ltd	Tokyo, Japan	71218	Bud Radio Inc	Cleveland Ohio	78283	Sigbal Indicator Corp.	New York N Y
04713	Motorola, Inc., Semiconductor Prod. Div	Phoenix, Arizona	12930	Delta Semiconductor Inc.	Newport Beach, Calif.	71286	Camloc Fastener Corp	Paramus N J	78290	Stiuthers-Dunn Inc	Pitman N J
04732	Filttron Co., Inc., Western Div	Culver City, Calif	13103	Thermolloy	Dallas, Texas	71313	Allen D. Cardwell Electronic Prod. Corp.	Plainville, Conn.	78452	Strompson-Bremer & Co	Chicago Ill
04773	Automatic Electric Co.	Northlake, Ill.	13396	Telefunken (G M B H)	Hannover Germany	71400	Bussmann Fuse Div. of McGraw-Edison Co.	St Louis Mo	78471	Tilley Mig Co	San Francisco Calif
04777	Automatic Electric Sales Corp.	Northlake, Ill	13835	Midland Mig Co	Kansas City, Kansas	71436	Chicago Condenser Corp	Chicago, Ill	78488	Stackpole Carbon Co.	St Marys, Pa
04796	Sequoia Wire & Cable Co.	Redwood City Calif.	14099	Sem-Tech	Newbury Park, Calif.	71450	CTS Corp.	Elkhardt Ind.	78493	Standard Thomson Corp	Waltham, Mass
04811	Precision Coil Spring Co.	El Monte, Calif.	14193	Calif. Resistor Corp.	Santa Monica, Calif.	71468	Cannon Electric Co.	Los Angeles, Calif	78553	Tinnerman Products Inc	Cleveland Ohio
04870	P M Motor Company	Chicago 44, Ill	14298	American Components, Inc.	Conshohocken, Pa.	71471	Cinema Engineering Co.	Burbank, Calif.	78790	Transformer Engineers	Pasadena Calif.
05006	Twentieth Century Plastics, Inc	Los Angeles Calif.	14655	Cornell Dubilier Elec. Corp.	So. Plainfield, N.J	71482	C. P. Clare & Co.	Chicago, Ill	78947	Ucinite Co	Newtownville Mass
05277	Westinghouse Electric Corp. Semi-Conductor Dept	Youngwood Pa.	14960	Williams Mig Co	San Jose, Calif	71590	CentralRad Div of Globe Union Inc	Milwaukee Wis	79142	Veeder Root Inc	Hartford Conn
05347	Ultronic Inc	San Mateo Calif	15203	Webster Electronics Co. Inc.	Brooklyn, N Y	71616	Commercial Plastics Co	Chicago Ill	79251	Wenco Mig Co	Chicago Ill
05593	Illuminonic Engineering Co	Sunnyvale, Calif	15291	Adjustable Bushing Co	N Hollywood, Calif	71700	The Cornish Wire Co	New York N Y	79727	Continental-Wirt Electronics Corp	Philadelphia Pa
05616	Cosmo Plastic (Co Electrical Spec Co)	Cleveland, Ohio	15772	Twentieth Century Coil Spring Co	Santa Clara, Calif	71744	Chicago Miniature Lamp Works	Chicago, Ill.	79963	Zienck Mig Corp	New Rochelle N Y
05624	Barber Colman Co	Rockford, Ill	15809	The Daven Co	Livingston, N J	71753	A.O. Smith Corp.	Crowley Div West Orange, N J	80031	Mepco Division of Sessions Clock Co	Morristown N J
05728	Tiffen Optical Co	Roslyn Heights, Long Island N Y.	16037	Spruce Pine Mica Co	Spruce Pine, N C	71785	Cinch Mig Corp	Chicago, Ill.	80120	Schnitzer Alloy Products	Elizabeth, N J
05729	Metropolitan Telecommunications Corp. Metro Cap. Division	Brooklyn N Y	16688	De Jui Amco Corporation	Lodi, N J	71984	Dow Corning Corp	Midland Mich.	80130	Times Facsimile Corp	New York N Y
05783	Stewart Engineering Co.	Santa Cruz, Calif	16758	Delco Radio Div. of G M Corp	Long Island City I, N Y	72092	Eitel McCullough Inc	San Bruno Calif	80131	Electronic Industries Association	Any brand Washington D C
05820	Wakefield Engineering Inc	Wakefield, Mass	17109	Thermometrics Inc	Canoga Park, Calif.	72136	Electro Motive Mig Co Inc	Willmantic Conn	80207	Unimax Switch, Div. of W L Maxson Corp	Wallingford Conn
06004	The Bassick Co	Bridgeport, Conn	17474	Tranex Company	Mountain View Calif	72354	John E. Fast & Co.	Chicago Ill	80248	United Transformer Corp.	New York N Y
06175	Bausch and Lomb Optical Co	Rochester N Y	18486	Radio Industries	Des Plaines Ill	72619	Dialight Corp.	Brooklyn, N Y	80294	Bourns Laboratories, Inc	Riverside, Calif
06402	E T A Products Co. of America	Chicago Ill	18583	Curtis Instrument Inc	Mt Kisco, N.Y	72636	General Ceramics Corp	Keasbey N J	80411	Acio Div of Robertshaw	Columbus 16 Ohio
06475	Western Devices, Inc.	Inglewood Calif.	18873	E I DuPont and Co Inc	Wilmington, Del.	72699	General Instrument Corp Semiconductor Div	Newark, N J	80486	All Star Products Inc	Deliance Ohio
06540	Anatone Electronic Hardware Co Inc	New Rochelle N Y	19315	Eclipse Pioneer Div of Bendix Aviation Corp	Teterboro, N J	72758	Guard-Hopkins	Oakland Calif.	80509	Avery Adhesive Label Corp	Monrovia Calif
06555	Beede Electrical Instrument Co Inc	Peacook, N H	19500	Thomas A Edison Industries, Div of McGraw-Edison Co	West Orange, N J	72765	Drake Mig. Co.	Chicago Ill.	80583	Hammerlund Co Inc	New York N Y
06751	U S Sencor Division of Nuclear Corp	Phoenix, Arizona	19701	Electra Manufacturing Co	Kansas City, Mo.	72825	Hugh H. Eby Inc	Philadelphia, Pa	80640	Stevens Arnold Co Inc	Boston Mass
06812	Torrington Mig. Co., West Div	Van Nuys, Calif	20183	Electronic Tube Corp.	Philadelphia, Pa	72826	Gudeman Co	Chicago Ill	81030	International Instruments Inc	New Haven Conn
07088	Kelvin Electric Co	Van Nuys Calif	21226	Executive Inc.	New York N Y	72964	Robert M. Hadley Co	Los Angeles Calif.	81073	Grayhill Co	LaGrange Ill
			21520	Fanstel Metallurgical Corp.	No Chicago Ill.	72982	Erie Resistor Corp	Erie, Pa.	81095	Triad Transformer Corp	Venice Calif
			21335	The Fafnir Bearing Co	New Britain, Conn	73061	Hansen Mig. Co Inc	Princeton, Ind.	81312	Winchester Electron cs Corp	Norwalk Conn
			21964	Fed Telephone and Radio Corp	Clifton, N J	73076	H M Harper Co	Chicago, Ill			
			24446	General Electric Co	Schenectady N Y	73138	Helipot Div of Beckman Instruments, Inc	Fullerton, Calif			
			24455	G E Lamp Division Nela Park	Cleveland Ohio						

00015-39  
Revised February 1965

From FSC Handbook Supplements  
H4-1 Dated DECEMBER 1964  
H4 2 Dated MARCH 1962

Table 6-3. Code List of Manufacturers (Cont'd)

Code No	Manufacturer	Address	Code No	Manufacturer	Address	Code No	Manufacturer	Address	Code No	Manufacturer	Address
81349	Military Specification		85474	R M Bracamonte & Co	San Francisco Calif	93829	G V Controls	Livngston N J	98220	Francis L. Mosley	Pasadena Calif.
81415	Wilkor Products Inc	Cleveland Ohio	85660	Koiled Kords Inc	New Haven Conn	93983	Insuline Van Norman Ind Inc	Manchester N H	98278	Microdot Inc	Pasadena Calif
81453	Raytheon Mfg Co	Industrial Components Div Industr Tube Operations	85911	Seamless Rubber Co	Chicago Ill		Electronic Division	Bayonne, N J	98291	Sealectro Corp	Mamareock N Y
8,483	International Rectifier Corp	El Segundo Calif	86197	Clifton Precision Products	Clifton Heights Pa	94137	General Cable Corp	Quincy Mass	98405	Carad Corp	Redwood City Calif.
81541	The Airpax Products Co	Cambridge Mass	86579	Precision Rubber Products Corp	Dayton Ohio	94144	Raytheon Mfg Co	Industrial Components Div v Receiving Tube Operation	98731	General Mills	Minneapolis Minn
81860	Barry Controls Inc	Watertown Mass	86584	Radio Corp of America RCA	Harrison N J	94145	Raytheon Mfg Co	Semiconductor Div California Street Plant	98821	North Hills Electric Co	Minneapolis N Y
82042	Carter Parts Co	Skok e Ill	87216	Phico Corporation (Lansdale Division)	Lansdale Pa	94148	Scientific Radio Products Inc	Newton Mass	98925	Clevite Transistor Prod Div of Clevite Corp	Waltham Mass
82142	Jefferis Electronics Division of Speer Carbon Co	Du Bois Pa	87473	Western Fibrous Glass Products Co	San Francisco Calif	94154	Tung Sol Electric Inc	Leveland Colo	98978	International Electronic Research Corp	Burbank, Calif.
82170	Allen B DuMont Labs Inc	Clifton N J	87664	Van Waters & Rogers Inc	Seattle Wash	94197	Curtiss Wright Corp	Newark N J	99109	Columbia Technical Corp	New York N Y
82209	Maguire Industries Inc	Greenwich Conn	87930	Tower Mfg Corp	Providence R I	94222	Southco Div of S Chester Corp	East Paterson, N J	99313	Varian Associates	Palo Alto Calif
82219	Sylvania Electric Prod Inc	Emporium Pa	88140	Cutter Hammer Inc.	Lincoln Ill	94222	Southco Div of S Chester Corp	Lester Pa	99515	Marshall Industries Electron Products Division	Pasadena Calif
82376	Astron Co	East Newark N J	88220	Gould National Batteries Inc	St Paul Minn	94310	Trio Ohm Prod Div of Model Engineering and Mfg Co	Chicago Ill	99707	Control Switch Division of America	Controls Co El Segundo, Calif
82389	Switchcraft Inc	Chicago Ill	88598	General Mills Inc	Buffalo N Y	94330	Wire Cloth Products Inc	Chicago Ill	99800	Delevan Electronics Corp.	East Aurora N Y
82647	Metals and Controls Inc	Div of Texas Instruments Inc	89231	Graybar Electric Co	Oakland Calif	94682	Worcester Pressed Aluminum Corp	Worcester Mass.	99848	Wilco Corporation	Indianapolis Ind
82656	Research Products Corp	Madison Wis	89462	Waldes Kohaupt Inc	Cambridge Mass				99934	Renbrandt, Inc	Boston Mass.
82677	Rotron Manufacturing Co Inc	Woodstock N Y	89473	General Electric Distributing Corp	Schenectady N Y	95023	Phibrick Researchers, Inc	Boston Mass	99942	Hoffman Semiconductor Div of Hoffman Electronics Corp	Evanston Ill
82693	Vector Electronic Co	Glendale Calif	89636	Carter Parts Div of Economy Baler Co	Chicago Ill	95236	Allites Products Corp	Miami Fla	99957	Technology Instrument Corp of Calif.	Newbury Park, Calif.
83053	Western Washer Mfr Co	Los Angeles Calif	89665	United Transformer Co	Chicago Ill	95238	Continental Connector Corp	Woodside N Y			
83058	Carr Fastener Co	Cambridge Mass	90179	U S Rubber Co 'Mechanical' Goods Div	Passaic N J	95263	Leecraft Mfg Co Inc	New York N Y			
83086	New Hampshire Ball Bearing Inc	Peterborough N H	90970	Bearing Engineering Co	San Francisco Calif	95264	Leroo Electronics Inc.	Burbank Calif.			
83125	Pyramid Electric Co	Darlington S.C	91260	Connor Spring Mfg. Co	San Francisco Calif	95285	National Coil Co	Sheridan, Wyo.			
83148	Electro Cords Co	Los Angeles Calif	91345	Miller Dial & Nameplate Co	El Monte Calif	95275	Vitramon Inc	Bridgeport Conn			
83186	Victory Engineering Corp	Springfield N J	91418	Radio Materials Co	Chicago Ill	95348	Gordas Corp	Bloomfield N J			
83298	Bendix Corp	Red Bank N J	91506	Augal Brothers Inc	Attleboro, Mass	95354	Methode Mfg Co	Chicago, Ill.			
83315	Hubbell Corp	Mundelein Ill	91637	Dale Electronics Inc	Columbus Nebr	95712	Dage Electric Co Inc	Franklin Ind			
83330	Smith Herman H Inc	Brooklyn N Y	91662	Elco Corp	Philadelphia Pa	95987	Weckesser Co	Chicago, Ill.			
83385	Centril Screw Co	Chicago Ill	91737	Gremar Mfg Co Inc	Wakfield, Mass	96067	Huggins Laboratories	Sunnyvale, Calif			
83501	Gavitt Wire and Cable Co	Div. of Amerace Corp Brookfield Mass	91827	K F Development Co	Redwood City Calif.	96095	H Q Division of Aerovox	Olean, N Y			
83594	Burroughs Corp., Electronic Tube Div	Plainfield N J	91929	Minneapolis Honeywell Regulator Co	Freeport Ill	96256	Thordarson-Meissner Div of Maguire Industries Inc	Mt. Carmel Ill			
83740	Eveready Battery	New York N Y	91961	Nahm Bros Spring Co	Oakland, Calif	96296	Solar Manufacturing Co	Los Angeles, Calif.			
83777	Model Eng. and Mfg. Inc	Huntington Ind	92180	Triu-Connector Corp	Peabody Mass	96330	Carlton Screw Co	Chicago, Ill			
83821	Loyd Scruggs Co	Festus Mo	92196	Universal Metal Prod Inc	Bassett Puente Calif	96341	Microwave Associates, Inc.	Burlington, Mass.			
84171	Arco Electronics Inc	New York N Y	92367	Elgeet Optical Co Inc	Rochester N Y	96501	Excel Transformer Co.	Oakland, Calif			
84396	A J Glesener Co Inc	San Francisco Calif	92607	Tinsolite Insulated Wire Co	Tarrytown N Y	97464	Industrial Retaining Ring Co	Irvington N J			
84411	Good All Electric Mfg Co	Ogallala Neb	93332	Sylvania Electric Prod Inc	Woburn Mass	97539	Automatic and Precision Mfg Co	Yonkers N Y			
84970	Sarkes Tarzian Inc	Bloomington Ind		Semiconductor Div		97966	CBS Electronics	Danvers, Mass			
85454	Boonton Molding Company	Boonton N J	93369	Robbins and Myers Inc	New York N Y	97979	Reon Resistor Corp	Yonkers, N Y			
85471	A B Boyd Co	San Francisco Calif	93410	Stevens Mfg Co Inc	Mansfield Ohio	98141	Axel Brothers Inc	Jamaica, N Y			
			93788	Howard J Smith Inc	Port Monmouth N J	98159	Rubber Teck, Inc	Gardena Calif.			

THE FOLLOWING H-P VENDORS HAVE NO NUMBER ASSIGNED IN THE LATEST SUPPLEMENT TO THE FEDERAL SUPPLY CODE FOR MANUFACTURERS HANDBOOK

J0000 Winchester Electronics Inc Santa Monica Calif

0000F Malco Tool and Die Los Angeles Calif.

0000M Western Coil Div of Automatic Ind. Inc. Redwood City, Calif.

0000P Ty Car Mfg. Co., Inc. Holliston, Mass.

0000Z Willow Leather Products Corp Newark, N J

0000A British Radio Electronics Ltd. Washington, D. C.

000AB ETA England

000AC Indiana General Corp., Elect. Div. Indiana

000BB Precision Instrument Components Co Van Nuys, Calif.

000MM Rubber Eng. & Development Hayward, Calif.

000NN A "N" D Manufacturing Co San Jose 27 Calif.

000QQ Cooltron Oakland, Calif.

000SS Control of Elgin Watch Co Burbank, Calif.

000WW California Eastern Lab Burlingame, Calif.

000YY S K Smith Co Los Angeles 45 Calif

52983 Sanborn Co. Waltham, Mass.

TABLE IA-1. Option 14, Replaceable Parts

Action *	Ref Desig	hp Part Number	Description	Mfr	Mfr Part No.
CHG	A1	01415-66518	Assy: etched ckt (time base)	hp	
CHG	A2	01415-66517	Assy: etched ckt (pulse generator)	hp	
CHG	A3	01415-66516	Assy: etched ckt (sampler)	hp	
CHG	A4	01415-66519	Assy: etched ckt (input amplifier)	hp	
CHG	A9	01415-61905	Assy: switch (time scale)	hp	
CHG	C101	0140-0235	C: fxd mica 2250 pf 1% 300 vdcw	14655	RDM20F225OQF3C
CHG	C102	0140-0235	C: fxd mica 2250 pf 1% 300 vdcw	14655	RDM20F225OQF3C
CHG	C146	0140-0182	C: fxd mica 5000 pf 2% 300 vdcw	04062	RDM20F50263C
DEL	C325	0140-0220			
ADD	C335	0160-2331	C: fxd mica 8200 pf 1% vdcw	04062	RDM20F822F1S
ADD	C336	0140-0150	C: fxd mica 731.5 pf 1% 300 vdcw	04062	RDM15F731J5QF3S
CHG	L170	9140-0041	Coil: fxd rf 2.5 mh	92054	51 4471 25
ADD	L302	9170-0029	Inductor: ferrite bead	02114	56 590 654A
ADD	L303	9170-0029	Inductor: ferrite bead (2 required)	02114	56 590 654A
CHG	L401	9140-0096	Coil: fxd rf 1.0 $\mu$ h	hp	
CHG	L402	9140-0096	Coil: fxd rf 1.0 $\mu$ h	hp	
ADD	L405	9140-0137	Coil: fxd rf 1.0 mh	hp	
CHG	R149	0684-1031	R: fxd comp 10K ohms 10% 1/4W	01121	CB 1031
DEL	R335	0683-1035			
CHG	R336	0683-4715	R: fxd comp 470 ohms 5% 1/4W	01121	CB 4715
ADD	R337	0683-3315	R: fxd comp 330 ohms 5% 1/4W	01121	CB 3315
ADD	R338	0683-1035	R: fxd comp 10K ohms 5% 1/4W	01121	CB 1035
CHG	R422	0683-2265	R: fxd comp 22M ohms 5% 1/4W	01121	CB 2265
CHG	R423	0683-2265	R: fxd comp 22M ohms 5% 1/4W	01121	CB 2265

\* ADD= Add item. DEL= Delete item. CHG= Change item.

## APPENDIX I

### OPTIONS

#### OPTION 14.

The Model 1415A Time Domain Reflectometer with Option 14 is a standard hp Model 1415A with an additional position added to the DISTANCE/TIME switch. This added position is equal to 1000 nsec/cm expressed in time, or 10,000 CM LINE/CM DISPLAY (polyethylene) and 15,000 CM LINE/CM DISPLAY (air) expressed in distance. To provide this extended range, changes have been made in several circuits resulting in several changes to the specifications. To provide coverage for an Option 14 instrument, the following changes must be made to this manual.

Table 1-1,

#### SYSTEM

Rise Time: Less than 200 psec.

Repetition Rate: 30 kc nominal.

#### SIGNAL CHANNEL

Rise Time: Approximately 190 psec.

Noise and Internal Pickup, Peak: 0.25% of step (terminated into 50 ohms).

#### STEP GENERATOR

Droop: Less than 2%.

#### DISTANCE/TIME SCALE

Polyethylene Line ( $\epsilon = 2.25$ ): 200 cm/cm to 100 m/cm.

Air Line ( $\epsilon = 1$ ): 300 cm/cm to 150 m/cm.

Time Scale: 20 nsec/cm to 1  $\mu$ sec/cm,  $\pm 5\%$  accuracy.

Paragraph 3-8, fourth-from-last line,  
Change "3000" to "600".

Paragraph 3-8, last line,  
Change "30,000" to "6000".

Paragraph 4-2, line 7; and 4-6, line 2,  
Change "150 kc" to "30 kc".

Paragraph 5-12, step f,  
Change "0.15" to "0.20", and "1.5" to "2.0".

Paragraph 5-14, step b,  
Change "1 cm" to "2 cm".

Paragraph 5-15, step d, last line,  
Change to read "less than 0.5 cm peak."

Paragraph 5-27, step c,  
Change SWEEP TIME TO "5  $\mu$ sec/cm".

Paragraph 5-27, step d, first line,  
Change "5 microseconds" to 30 microseconds".

Paragraph 5-38, step a,  
Change NSEC/CM to "1000".

Figures 5-5 and 5-13,  
Change waveform time reference from "7.5  $\mu$ SEC" to "30  $\mu$ SEC".

Figure 5-6,

C101 and C102: Change value to 2250 pf.

C146: Change value to 5000 pf.

L170: Change value to 2.5 MH.

R149: Change value to 10K ohms.

Figure 5-12,

Replace with Figure IA-1 of this Appendix.

Figure 5-14,

Replace S301 switch circuit with Figure IA-2 of this Appendix.

C325: Delete

Figure 5-18,

L401 and L402: Change value to 1.0  $\mu$ h.

R422 and R423: Change value to 22M ohms.

Add L405, 1.0 mh, in the -12.6 v input line (outside the shield).

Table 6-1 and 6-2,

Make changes as indicated in Table IA-1 of this Appendix.

In all other respects, the Option 14 instrument is electrically identical to the standard Model 1415A.

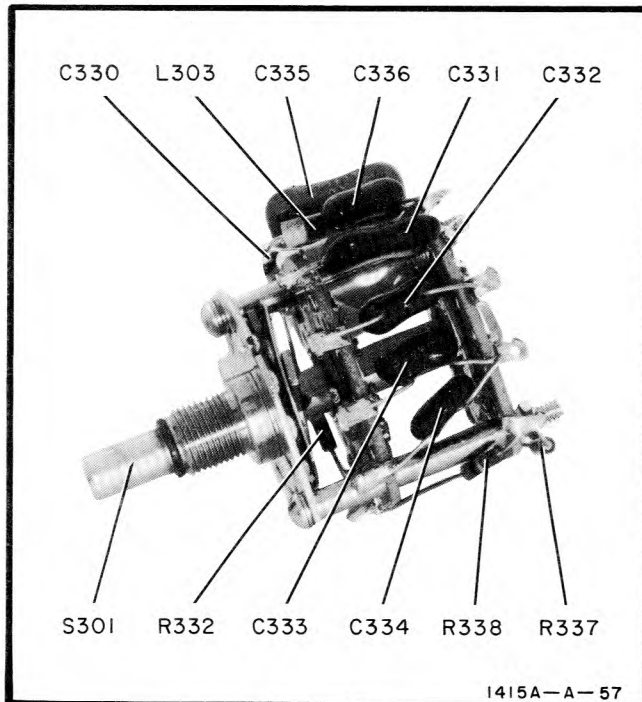

Figure IA-1. Component Locations on A9, Option 14.

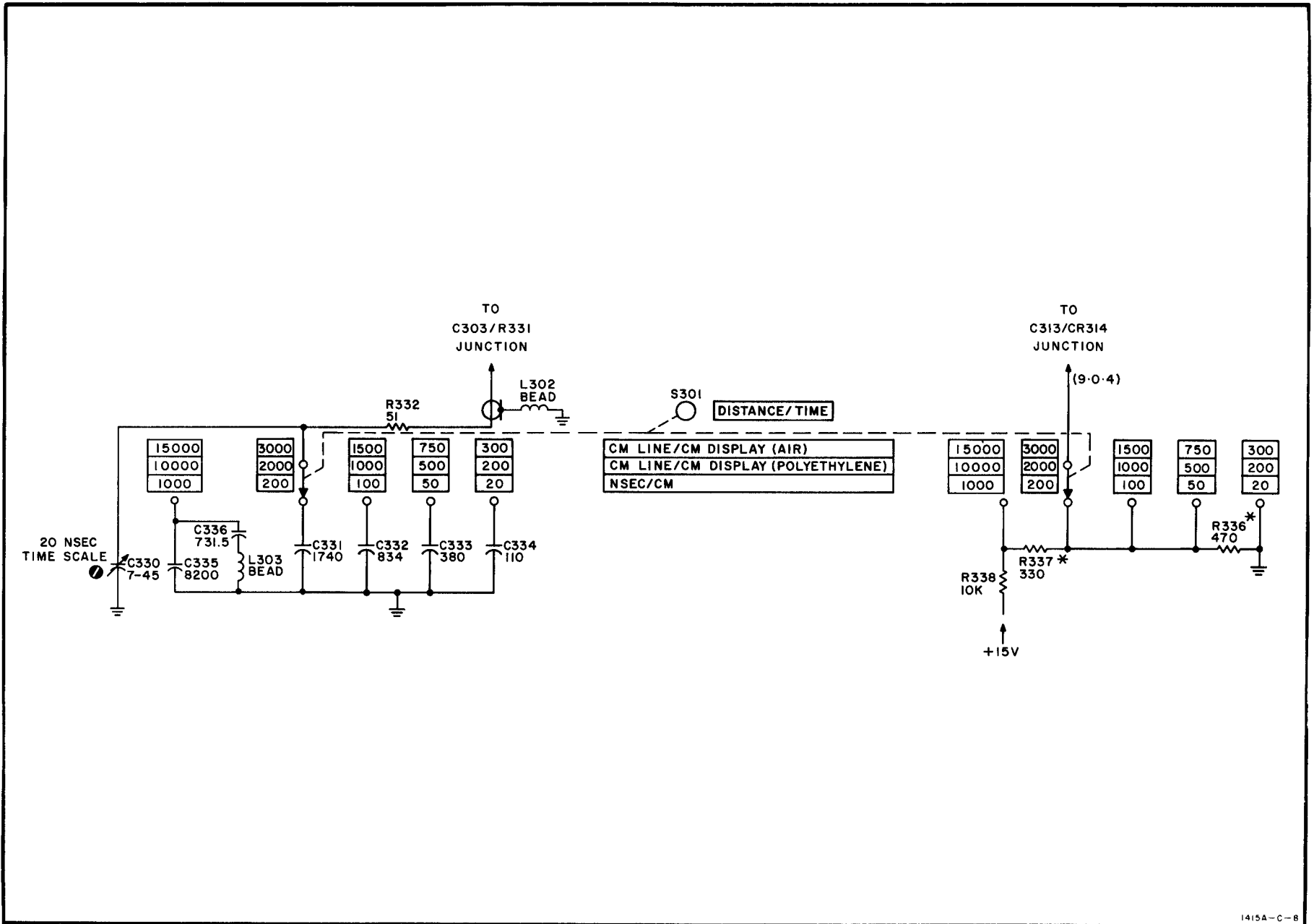

Figure IA-2. Option 14 Distance/Time Switch Schematic.

## APPENDIX II MANUAL CHANGES

This appendix contains information on changes required to adapt this manual to an instrument with a serial prefix listed in the table below. Check for your instrument serial prefix and make the numbered changes indicated. Note that these changes adapt the manual to cover a particular instrument as manufactured and therefore will not apply to an instrument subsequently modified in the field. Refer back to Section I for information on errata in this manual and on any other instrument serial prefix not covered in this appendix.

Instrument Serial Prefix	Make Numbered Changes
607-	1, 2
548-	1
545-	1, 3, 4,
526-	1, 3 thru 5
521-	1, 3 thru 6
518-	1, 4 thru 7
512-	1, 4 thru 8
501-	4 thru 13
450-	4 thru 9, 11 thru 14
445-	4 thru 9, 12 thru 15
439-	4 thru 9, 12 thru 17
430-	4 thru 9, 13 thru 18
426-	4 thru 9, 13 thru 19
411-	4 thru 9, 14, 15, 17 thru 20

### CHANGE 1

Figure 5-6,

Add grounded shield to enclose both 9-1-3 leads of R110.

Move R112 from Q102 collector circuit to Q102 base circuit (R112 is now located in the lead coming from CW end of R110).

### CHANGE 2

Figure 5-6,

Add: C105 (680 pf) in parallel with R110.

Add: L102 (BEAD) in series with ground and shield of R110 leads.

Tables 6-1 and 6-2,

Add: C105, hp Part No. 0140-0208; C: fxd, mica, 680 pf, 5%; Mfr hp.

Add: L102, hp Part No. 9170-0029; Inductor: ferrite bead; Mfr 02114; Mfr Part No. 56-590-654A.

### CHANGE 3

Figures 5-11 and 5-26,

R230: Change value to 10K ohms.

Tables 6-1 and 6-2,

R230: Change to hp Part No. 0683-1035, R: fxd, comp, 10K ohms, 5%, 1/4W; Mfr 01121; Mfr Part No CB1035.

### CHANGE 4

Figure 5-11,

C223: Change value to 110 pf.

R218: Change value to 2200 ohms.

Figure 5-14,

Delete L302.

Tables 6-1 and 6-2,

C223: Change to hp Part No. 0140-0194; C: fxd, mica, 110 pf, 5%, 300VDCW; Mfr 04062; Mfr Part No. RDM15F111J3C.

L302: Delete

R218: Change to hp Part No. 0684-2221; R: fxd, comp, 2200 ohms, 10%, 1/4W; Mfr 01121; Mfr Part No. CB2221.

Under Miscellaneous,

Change: Cable, main harness to hp Part No. 01415-61612.

Change: Cable, manual scan to hp Part No. 01415-61613.

### CHANGE 5

Tables 6-1 and 6-2,

Q302, Q303: Change to hp Part No. 1854-0005;

Transistor: si, npn, 2N708; Mfr 07263; Mfr Part No. 2N708.

Under Miscellaneous:

Add: hp Part No. 01415-61101: Heat sink; Mfr hp.

### CHANGE 6

Figure 5-6,

R129: Change value to 39 ohms.

Tables 6-1 and 6-2,

R129: Change to hp Part No. 0684-3901; R: fxd, comp, 39 ohms, 10%, 1/4W; Mfr 01121; Mfr Part No. CB3901.

### CHANGE 7

Figure 5-11,

C212: Change value to 0.1  $\mu$ f.

Delete R230.

Figure 5-18,

Add: R415 (68 ohms) in parallel with twisted lead output to sampler block.

Figure 5-26,

Delete R230, Pin 2 is now N.C.

Tables 6-1 and 6-2,

C212: Change to hp Part No. 0160-0168; C: fxd, my, 0.1  $\mu$ f, 10%, 200VDCW; Mfr hp.

R230: Delete.

Add: R415: hp Part No. 0684-6801; R: fxd, comp 68 ohms, 10%, 1/4W; Mfr 01121; Mfr Part No. CB6801.

**CHANGE 8**

Figure 5-24,

R601: Change value to 12K ohms.

Tables 6-1 and 6-2,

R601, R603: Change to hp Part No. 0684-1231;  
R: fxd, comp, 12K ohms, 5%, 1/4W; Mfr 01121;  
Mfr Part No. CB1231.

**CHANGE 9**

Paragraph 3-8,

Replace the complete paragraph with the following:  
"3-8. SCANNING. This control function consists of two controls which set up the horizontal scan mode. The NORMAL/DETAIL slide switch selects either normal scanning of the input signal (about 3000 samples per sweep, repetition rate of 50 cps) or detail scanning which provides a higher sampling density for a more detailed sweep (about 30,000 samples per sweep, repetition rate of 5 cps). The INT/MANUAL control selects either internal scanning (when turned fully counterclockwise) of the input signal or, when rotated clockwise, provides a manual scanning capability.

Paragraph 3-12,

Delete Paragraph 3-12.

Figure 3-1,

Replace with Figure IIA-1 of this appendix.

Figure 3-2, step 4,

Change to read "Set SCANNING INT/MANUAL to INT."

Figure 3-5, step 3,

Delete Note.

Figure 3-6, step 4,

Delete Note.

Paragraph 4-6, second sentence,

Delete: "Narrow band - - - - interference band."

Paragraph 4-10, third sentence,

Replace with the following: "This voltage may be an internally-generated sawtooth (SCANNING control switched to INT) or manually determined by operating R206 (MANUAL)."

Paragraph 4-11,

Replace four sentences beginning with "With the SWEEP switch - - -" and ending with "- - - approximately zero volts." with the following sentence: "With the MANUAL/INT control in MANUAL scan condition, the dc voltage on the wiper of R206 is the slow ramp signal."

Figure 4-3,

Delete: "RECORD SWEEP GENERATOR Q215" block, Record/Reset section of switch, callouts "Record/Reset" and "Sweep Switch S203," and switch mechanical linkage.

Change "Normal Detail" callout to Normal/Detail/Int."

Paragraph 4-24, sixth sentence,

Delete: "Broad band - - - - interference band."

Paragraphs 5-9, 5-25 step a, and Table 5-5,

Change "SWEEP..... NORMAL" to "SCANNING  
..... NORMAL, INT."

Paragraphs 5-14 steps a and c, and 5-38 step a,  
Change "SWEEP" to "SCANNING."

Paragraph 5-44, second sentence,

Change to read: "Set SCANNING INT/MANUAL control to MANUAL and adjust so that the dot is - - - -."

Figure 5-6,

Delete R110, and connect R112 in parallel with Q102 base and collector.

R103: Change value to 15K ohms.

Figure 5-8,

Delete

Figure 5-9,

Replace with Figure IIA-2 of this appendix.

Figure 5-11,

Delete: S203, R208 thru R211, C204, CR210, and Q215.

Connect S201, J201, and associated components as shown in Figure IIA-3 of this appendix.

Delete R276 and R277, and connect R275 to +15V. Q210/Q211: Change transistors to NPN and connect both collectors to +15V. Connect R281 and R282 to -12.6V, and change value of R282 to 2200 ohms.

Change dc voltages as follows:

Q210 base to +2.85V

Q211 base to +2.8V

Figure 5-14,

L301: Change value to 500  $\mu$ h.

C322: Change value to 80 pf.

R325: Change value to 100K ohms.

Figure 5-18,

C403: Change value to 1.0  $\mu$ f.

Delete asterisk on V401 designator.

Figures 5-19 and 5-20,

Replace with Figures IIA-4 and IIA-5 of this appendix.

Figure 5-23,

R528: Change value to 68K ohms.

Delete: R598A and R598B.

Include C581 on Amplifier board A5.

Delete R534, and connect V503, pin 12 directly to V401, pin 12.

Figure 5-24,

Delete R609 and its leads.

Delete CR603, and connect Q601 emitter directly to ground.

Figure 5-25,

Replace with Figure IIA-6 of this appendix.

Tables 6-1 and 6-2,

Make changes, additions, and deletions as shown in Table IIA-1 of this appendix.

**CHANGE 10**

Figure 5-6,

C101: Change value to 680 pf.

Tables 6-1 and 6-2,

C101: Change to  $\text{\textcircled{P}}$  Part No. 0140-0208; C: fxd, mica, 680 pf, 5%, 300VDCW; Mfr hp.**CHANGE 11**

Tables 6-1 and 6-2,

R207: Change to  $\text{\textcircled{P}}$  Part No. 0684-3911; R: fxd, comp, 390 ohms, 10%, 1/4W; Mfr 01121; Mfr Part No. CB 3911.**CHANGE 12**

Tables 6-1 and 6-2,

A1: Change to  $\text{\textcircled{P}}$  Part No. 01415-66511.**CHANGE 13**

Figure 5-11,

R271: Change value to 510 ohms.

Tables 6-1 and 6-2,

R271: Change to  $\text{\textcircled{P}}$  Part No. 0683-5115; R: fxd, comp, 510 ohms, 10%, 1/4W; Mfr 01121; Mfr Part No. CB 5115.**CHANGE 14**

Paragraph 4-2, line 7 and Paragraph 4-6, line 2,

Change "150 kc" to "200 kc."

Figure 5-5,

Change "7.5  $\mu$ sec" to "5  $\mu$ sec."

Figure 5-6,

C101: Change value to 320 pf.

C146: Change value to 1000 pf.

Tables 6-1 and 6-2,

C101: Change to  $\text{\textcircled{P}}$  Part No. 0140-0226; C: fxd, mica, 320 pf, 1%, 300VDCW; Mfr 04062; Mfr Part No. DM15F 321F 300V.C146: Change to  $\text{\textcircled{P}}$  Part No. 0150-0069; C: fxd, cer, 1000 pf, +100-20%, 500VDCW; Mfr 72982; Mfr Part No. 801-010X5G0102Z.**CHANGE 15**

Figure 5-6,

R136: Change value to 200 ohms.

R149: Change value to 10K ohms.

Add: R145, 1500 ohms, between base of Q124 and ground.

Add: R147, 2200 ohms, and C147, 240 pf, in parallel between R149 and base of Q125.

Change dc voltages as follows:

Q121/Q124 bases to +4.5V.

Q121 emitter to +4.6V.

Q125 base to -12V.

Q125 collector to -6.4V.

Figure 5-11,

R207: Change value to 560 ohms.

Figure 5-22,

R503: Change value to 50K ohms.

R506: Change value to 18K ohms.

Tables 6-1 and 6-2,

Add: C147;  $\text{\textcircled{P}}$  Part No. 0140-0199; C: fxd, mica, 240 pf, 5%, 300VDCW; Mfr 04062; Mfr Part No. DM15F 241J 300V.Add: R145;  $\text{\textcircled{P}}$  Part No. 0684-1521; R: fxd, comp, 1500 ohms, 10%, 1/4W; Mfr 01121; Mfr Part No. CB 1521.Add: R147;  $\text{\textcircled{P}}$  Part No. 0684-2221; R: fxd, comp, 2200 ohms, 10%, 1/4W; Mfr 01121; Mfr Part No. CB 2221.R207: Change to  $\text{\textcircled{P}}$  Part No. 0684-5611; R: fxd, comp, 560 ohms, 10%, 1/4W; Mfr 01121; Mfr Part No. CB 5611.R503: Change to  $\text{\textcircled{P}}$  Part No. 2100-0141; R: var, comp, 50K ohms, 20%, 1/4W; Mfr hp.R506: Change to  $\text{\textcircled{P}}$  Part No. 0683-1835; R: fxd, comp, 18K ohms, 5%, 1/4W; Mfr 01121; Mfr Part No. CB 1835.**CHANGE 16**

Figure 5-6,

Add: C143, 120 pf, between base of Q124 and ground.

Tables 6-1 and 6-2,

Add: C143;  $\text{\textcircled{P}}$  Part No. 0140-0216; C: fxd, mica, 120 pf, 2%, 300VDCW; Mfr hp.**CHANGE 17**

Figure 5-6,

Add: C104, CR101, and L101 as shown in Figure IIA-7 of this appendix.

Figure 5-14,

Delete L301 and replace with short circuit.

Remove "F" from "+15VF" wherever it appears.

Figure 5-26,

P1: Change pin 21 callout to read "-12.6V to A1 and A6."

P2: Delete R608. Add WHT-VIO connection and callout "12.6V to A5 and front panel" to pin 21.

Tables 6-1 and 6-2,

Delete: L301 and R608.

Add: C104;  $\text{\textcircled{P}}$  Part No. 0140-0176; C: fxd, mica, 100 pf, 2%, 300VDCW; Mfr 04062; Mfr Part No. DM15F 101G 300V.Add: CR101;  $\text{\textcircled{P}}$  Part No. 1901-0040; Diode, Si; Mfr 07263; Mfr Part No. FDG 1088.Add: L101;  $\text{\textcircled{P}}$  Part No. 9140-0118, Coil, RF, fxd, 500  $\mu$ h, 5%; Mfr 99800; Mfr Part No. 2500-14.**CHANGE 18**

Figure 5-6,

Add: C120, 0.1  $\mu$ f, between the input end of L120 and ground.

Figure 5-26,

P1: Delete R607 and WHT-VIO connection to pin 23. Pin 23 is now "N. C."

Tables 6-1 and 6-2,

- A1: Change to  $hp$  Part No. 01415-66402.  
 Add: C120;  $hp$  Part No. 0150-0121; C: fxd, cer,  
 0.1  $\mu$  f, +80-20%, 50VDCW; Mfr 56289; Mfr  
 Part No. 5C50A.  
 Delete: R607.

### CHANGE 19

Figure 5-6,

- Add: C151, 22 pf, in parallel with R151.  
 R127: Change value to 100 ohms.

Tables 6-1 and 6-2,

- Add: C151;  $hp$  Part No. 0140-0145; C: fxd, mica,  
 22 pf, 5%, 500VDCW; Mfr 04062; Mfr Part No.  
 DM15C 220J.  
 R127: Change to  $hp$  Part No. 0684-1011; R: fxd,  
 comp, 100 ohms, 10%, 1/4W; Mfr 01121; Mfr  
 Part No. CB 1011.

### CHANGE 20

Figure 5-1,

- Add: "(Bottom-next to S501)" to Pulse Shape Adj

R172 callout.

Figure 5-4,

- Replace with Figure IIA-8 of this appendix.

Figure 5-6.

- Add: C143, 120 pf, in parallel with R143.  
 Change position of L170, R171, and R172 as shown  
 in Figure IIA-9 of this appendix.

Figure 5-11,

- R271, R275: Change value to 1000 ohms.

Tables 6-1 and 6-2,

- A2: Change to  $hp$  Part No. 01415-66504.  
 R271: Change to  $hp$  Part No. 210C-0169; R: var,  
 comp, 20K ohms, 30%, 1/4W; Mfr hp.  
 R271, R275: Change to  $hp$  Part No. 0684-1021;  
 R: fxd, comp, 1K ohms, 10%, 1/4W; Mfr 01121;  
 Mfr Part No. CB 1021.

- Add: C143;  $hp$  Part No. 0140-0216; C: fxd, mica,  
 120 pf, 2%, 300VDCW; Mfr hp.

Table IIA-1. Reference Designation Index and Replaceable Parts

ACTION *	CIRCUIT REFERENCE	$t_p$ PART NUMBER	DESCRIPTION	MFR	MFR PART NO.
CHG	A3	01415-66501	ASSY: ETCHED CIRCUIT (SAMPLER)	hp	
CHG	A6	01415-66507	ASSY: ETCHED CIRCUIT (PWR SUP)	hp	
CHG	A7	01415-66505	ASSY: ETCHED CIRCUIT (TRIMMER)	hp	
DEL	A13	01415-61904			
DEL	C204	0180-1706			
CHG	C322	0140-0215	C: FXD MICA 80 pf 2% 300VDCW	04062	DM15E 800G 300V
CHG	C403	0160-0127	C: FXD CER 1.0 $\mu$ f 20% 25VDCW	56289	5C13
CHG	C412, C413	0140-0205	C: FXD MICA 62 pf 5% 300VDCW	04062	DM15E 620J 300V
CHG	CR123	1912-0006	DIODE: GE TUNNEL 1N3718	03508	1N3718 SP
DEL	CR210	1901-0179			
DEL	CR603	1901-0040			
CHG	L301	9140-0118	COIL: RF FXD 500 $\mu$ h	99800	2500-14
CHG	Q101, Q102	1850-0158	TRANSISTOR: GE PNP 2N2635	01295	2N2635
CHG	Q210, Q211	1851-0024	TRANSISTOR: GE NPN 2N388A	01295	2N388A
DEL	Q215	1854-0033			
CHG	R103	0684-1531	R: FXD COMP 15K OHMS 10% 1/4W	01121	CB 1531
DEL	R110	2100-0421			
CHG	R205	0683-1325	R: FXD COMP 1300 OHMS 5% 1/4W	01121	CB 1325
CHG	R206	2100-0798	R: VAR COMP 5K OHMS 20% 1/2W	hp	
DEL	R208	0686-3055			
DEL	R209	0757-0442			
DEL	R210	0757-0452			
DEL	R211	0757-0418			
CHG	R273	2100-0802	R: VAR WW 5K OHMS 3% 7W 10-TURN	hp	
CHG	R275	0684-1521	R: FXD COMP 1500 OHMS 10% 1/4W	01121	CB 1521
DEL	R276	0757-0844			
DEL	R277	0757-0435			
CHG	R282	0684-2221	R: FXD COMP 2200 OHMS 10% 1/4W	01121	CB 2221
CHG	R302	0758-0018	R: FXD MET OX 15K OHMS 5% 1/2W	07115	C20
CHG	R311	0761-0072	R: FXD MET OX 11K OHMS 5% 1W	hp	
CHG	R325	0684-1041	R: FXD COMP 100K OHMS 10% 1/4W	01121	CB 1041
CHG	R526	0684-1541	R: FXD COMP 150K OHMS 10% 1/4W	01121	CB 1541
CHG	R528	0684-6831	R: FXD COMP 68K OHMS 10% 1/4W	01121	CB 6831
CHG	R529	0684-1521	R: FXD COMP 1500 OHMS 10% 1/4W	01121	CB 1521
CHG	R530	0684-1041	R: FXD COMP 100K OHMS 10% 1/4W	01121	CB 1041
DEL	R534	0684-1001			
DEL	R598	2100-1562			
DEL	R609	0683-1225			
ADD	S201	3101-0011	SWITCH: SLIDE DPDT (NORM/DET)	42190	4603
DEL	S203	NSR			
CHG	V401	1921-0017	ELECTRON TUBE: 7586	86684	7586
MISCELLANEOUS					
CHG		01415-00201	PANEL FRONT	hp	
DEL		01415-21101	COVER DIODE		
DEL		01415-21102	HEAT SINK		
CHG		01415-21201	CLAMP DIODE (USED WITH CR403)	hp	
DEL		01415-61101	HEAT SINK		
DEL		01415-61102	HEAT SINK		
DEL		01415-61103	COVER TRANSISTOR		
ADD		0370-0026	KNOB BLACK (MANUAL/INT)	hp	
CHG		0370-0113	KNOB BLACK (REFL COEFFICIENT)	hp	
CHG		0370-0114	KNOB RED (VERNIER)	hp	
DEL		0370-0151	KNOB BLACK (f. and BW)		
DEL		0370-0158	KNOB BLACK (HORIZ POS)		
ADD		1140-0002	KNOB DUO DIAL (MAGNIFIER DELAY)	73490	Model RB Duo-dial

\* ADD = Add item    DEL = Delete item    CHG = Change item

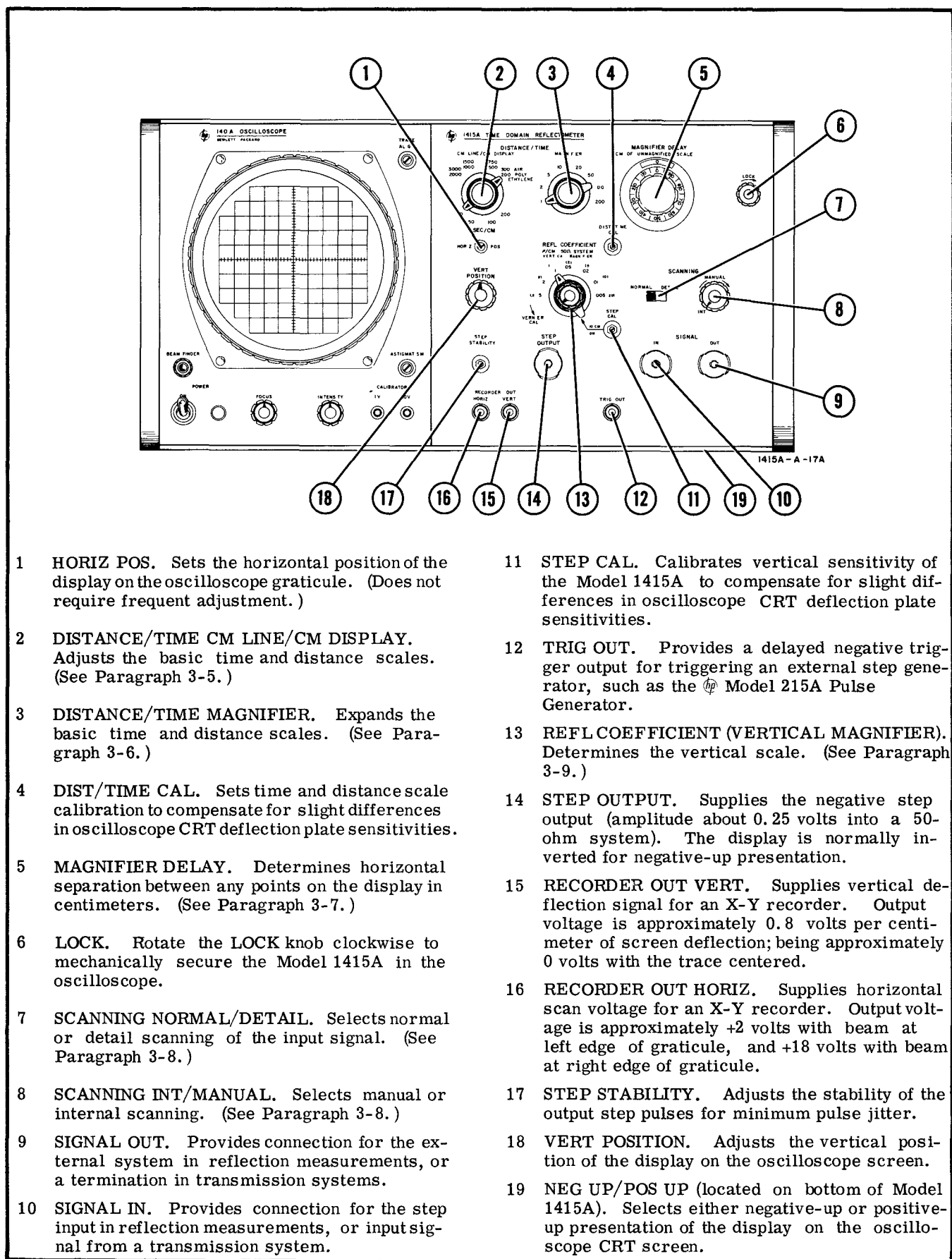

- |   |   |
|---|---|
| <p>1 HORIZ POS. Sets the horizontal position of the display on the oscilloscope graticule. (Does not require frequent adjustment.)</p> <p>2 DISTANCE/TIME CM LINE/CM DISPLAY. Adjusts the basic time and distance scales. (See Paragraph 3-5.)</p> <p>3 DISTANCE/TIME MAGNIFIER. Expands the basic time and distance scales. (See Paragraph 3-6.)</p> <p>4 DIST/TIME CAL. Sets time and distance scale calibration to compensate for slight differences in oscilloscope CRT deflection plate sensitivities.</p> <p>5 MAGNIFIER DELAY. Determines horizontal separation between any points on the display in centimeters. (See Paragraph 3-7.)</p> <p>6 LOCK. Rotate the LOCK knob clockwise to mechanically secure the Model 1415A in the oscilloscope.</p> <p>7 SCANNING NORMAL/DETAIL. Selects normal or detail scanning of the input signal. (See Paragraph 3-8.)</p> <p>8 SCANNING INT/MANUAL. Selects manual or internal scanning. (See Paragraph 3-8.)</p> <p>9 SIGNAL OUT. Provides connection for the external system in reflection measurements, or a termination in transmission systems.</p> <p>10 SIGNAL IN. Provides connection for the step input in reflection measurements, or input signal from a transmission system.</p> | <p>11 STEP CAL. Calibrates vertical sensitivity of the Model 1415A to compensate for slight differences in oscilloscope CRT deflection plate sensitivities.</p> <p>12 TRIG OUT. Provides a delayed negative trigger output for triggering an external step generator, such as the <math>\mu</math>p Model 215A Pulse Generator.</p> <p>13 REFL COEFFICIENT (VERTICAL MAGNIFIER). Determines the vertical scale. (See Paragraph 3-9.)</p> <p>14 STEP OUTPUT. Supplies the negative step output (amplitude about 0.25 volts into a 50-ohm system). The display is normally inverted for negative-up presentation.</p> <p>15 RECORDER OUT VERT. Supplies vertical deflection signal for an X-Y recorder. Output voltage is approximately 0.8 volts per centimeter of screen deflection; being approximately 0 volts with the trace centered.</p> <p>16 RECORDER OUT HORIZ. Supplies horizontal scan voltage for an X-Y recorder. Output voltage is approximately +2 volts with beam at left edge of graticule, and +18 volts with beam at right edge of graticule.</p> <p>17 STEP STABILITY. Adjusts the stability of the output step pulses for minimum pulse jitter.</p> <p>18 VERT POSITION. Adjusts the vertical position of the display on the oscilloscope screen.</p> <p>19 NEG UP/POS UP (located on bottom of Model 1415A). Selects either negative-up or positive-up presentation of the display on the oscilloscope CRT screen.</p> |
|---|---|

Figure IIA-1. Controls and Connectors





# SALES AND SERVICE OFFICES UNITED STATES and CANADA

## ALABAMA

Huntsville, 35802  
2003 Byrd Spring Rd. S.W.  
(205) 881-4591  
TWX: 510-579-2204

## ALASKA

Bellevue, Wash. 98004  
11656 N.E. 8th Street  
(206) 454-3971  
TWX: 910-443-2303

## ARIZONA

Scottsdale, 85251  
3009 No. Scottsdale Rd.  
(602) 945-7601  
TWX: 602-949-0111

Tucson, 85716  
232 So. Tucson Blvd.  
(602) 623-2564  
TWX: 602-792-2759

## CALIFORNIA

North Hollywood, 91604  
3939 Lankershim Blvd.  
(213) 877-1282 and 766-3811  
TWX: 910-499-2170

Sacramento, 95821  
2591 Carlsbad Ave  
(916) 482-1463  
TWX: 916-444-8683

San Diego, 92106  
1055 Shafter Street  
(714) 223-8103  
TWX: 714-276-4263

Palo Alto, 94303  
1101 Embarcadero Rd.  
(415) 327-6500  
TWX: 910-373-1280

## COLORADO

Englewood, 80110  
7965 East Prentice  
(303) 771-3455  
TWX: 910-935-0705

## CONNECTICUT

Middletown, 06457  
589 Saybrook Rd.  
(203) 346-6611  
TWX: 710-428-2036

## FLORIDA

Miami, 33125  
2907 Northwest 7th St.  
(305) 635-6461

Orlando, 32803  
621 Commonwealth Ave.  
(305) 425-5541  
TWX: 305-841-2568

St Petersburg, 33708  
410-150th Ave., Madeira Beach  
(813) 391-0211 and 391-1829  
TWX: 913-391-0666

## GEORGIA

Atlanta, 30305  
3110 Maple Drive, N.E.  
(404) 233-1141  
TWX: 810-751-3283

## HAWAII

North Hollywood, Calif. 91604  
3939 Lankershim Blvd.  
(213) 877-1282  
TWX: 910-499-2170

## ILLINOIS

Skokie, 60076  
5500 Howard Street  
(312) 677-0400  
TWX: 910-223-3613

## INDIANA

Indianapolis, 46205  
3919 Meadows Dr.  
(317) 546-4891  
TWX: 317-635-4300

## LOUISIANA

New Orleans  
(504) 522-4359

## MARYLAND

Baltimore, 21207  
6660 Security Blvd  
(301) 944-5400  
TWX: 710-862-0850

Rockville, 20852  
12303 Twinbrook Pkwy.  
(301) 427-7560  
TWX: 710-828-9684

## MASSACHUSETTS

Burlington, 01803  
Middlesex Turnpike  
(617) 272-9000  
TWX: 710-332-0382

## MICHIGAN

Southfield, 48076  
24315 Northwestern Hwy.  
(313) 353-9100  
TWX: 313-357-4425

## MINNESOTA

St. Paul, 55114  
2459 University Ave.  
(612) 646-7881  
TWX: 910-563-3734

## MISSOURI

Kansas City, 64114  
9208 Wyoming Place  
(816) 333-2445  
TWX: 910-771-2087

St. Louis, 63144  
2812 South Brentwood Blvd.  
(314) 644-0220  
TWX: 910-760-1670

## NEW JERSEY

Eatontown, 07724  
(201) 747-1060

Englewood, 07631  
391 Grand Avenue  
(201) 567-3933  
TWX: 510-230-9709

## NEW MEXICO

Albuquerque, 87108  
6501 Lomas Blvd., N.E.  
(505) 255-5586  
TWX: 910-989-1655

Las Cruces, 88001  
114 S. Water Street  
(505) 526-2486  
TWX: 910-983-0550

## NEW YORK

New York, 10021  
236 East 75th Street  
(212) 879-2023  
TWX: 710-581-4376

Rochester, 14623  
39 Saginaw Drive  
(716) 473-9500  
TWX: 510-253-5981

Poughkeepsie, 12601  
82 Washington Street  
(914) 454-7330  
TWX: 914-452-7425

Syracuse, 13211  
5858 East Molloy Rd.  
(315) 454-2486  
TWX: 710-541-0482

Endicott, 13764  
1219 Campville Rd.  
(607) 754-0050  
TWX: 510-252-0890

## NORTH CAROLINA

High Point, 27262  
1923 N. Main Street  
(919) 882-6873  
TWX: 510-926-1516

## OHIO

Cleveland, 44129  
5579 Pearl Road  
(216) 884-9209  
TWX: 216-888-0715

Dayton, 45409  
1250 W. Dorothy Lane  
(513) 298-0351  
TWX: 513-944-0090

## OKLAHOMA

Oklahoma City  
(405) 235-7062

## PENNSYLVANIA

Camp Hill  
(717) 737-6791

West Conshohocken, 19428  
144 Elizabeth Street  
(215) 248-1600 and 828-6200  
TWX: 518-660-8715

Monroeville, 15146  
Monroe Complex  
Building 2  
Suite 2  
Moss Side Blvd  
(412) 271-5227  
TWX: 710-797 3650

## TEXAS

Dallas, 75209  
P.O. Box 7166, 3605 Inwood Rd.  
(214) 357-1881  
TWX: 910-861-4081

Houston, 77027  
P.O. Box 22813, 4242 Richmond Ave.  
(713) 667-2407  
TWX: 713-571-1353

## UTAH

Salt Lake City, 84115  
1482 Major St.  
(801) 486-8166  
TWX: 801-521-2604

## VIRGINIA

Richmond, 23230  
2112 Spencer Road  
(703) 282-5451  
TWX: 710-956-0157

## WASHINGTON

Bellevue, 98004  
11656 N.E. 8th St.  
(206) 454-3971  
TWX: 910-443-2303

## GOVERNMENT CONTRACTING OFFICE

San Antonio, Texas 78226  
Hewlett-Packard  
Contract Marketing Division  
225 Billy Mitchell Road  
(512) 434-4171  
TWX: 512-571-0955

## CANADA

Montreal, Quebec  
Hewlett-Packard (Canada) Ltd.  
8270 Mayrand Street  
(514) 735-2273  
TWX: 610-421-3484  
Telex: 01-2819

Ottawa, Ontario  
Hewlett-Packard (Canada) Ltd.  
1762 Carling Avenue  
(613) 722-4223  
TWX: 610-562-1952

Toronto, Ontario  
Hewlett-Packard (Canada) Ltd.  
1415 Lawrence Avenue West  
(416) 249-9196  
TWX: 610-492-2382

Vancouver, B.C.  
Hewlett-Packard (Canada) Ltd.  
2184 W. Broadway  
(604) 738-7520  
TWX: 610-922-5059

# SALES AND SERVICE OFFICES INTERNATIONAL - Electronic Equipment

## ARGENTINA

Mauricio A. Suarez  
Telecomunicaciones  
Carlos Calvo 224  
Buenos Aires  
Tel. (30-6312) (34-9087)

## AUSTRALIA

Sample Electronics (Vic) Pty., Ltd.  
9-11 Cremorne Street  
Richmond E.1, Victoria  
Tel. 42-4757

Sample Electronics (N.S.W.) Pty, Ltd.  
4 Grose Street  
Glebe, New South Wales  
Tel. 69-6338

## AUSTRIA

Unifabor H.m.b.H.  
Wissenschaftliche Instrumente  
Rummelhardtgasse 6/3  
P.O. Box 33, Vienna IX/71  
Tel. 426 181

## BELGIUM

Hewlett-Packard Benelux S.A.  
20-24 rue de l'Hopital  
Brussels  
Tel. 11 22 20

## BRAZIL

Ciental Importacao e Comercio Ltda.  
Rua des Eliseu Guilherme, 62  
Sao Paulo 8  
Tel. 70-2318

## CHILE

Hector Calcagni  
Casilla 13942  
Santiago  
Tel. 6.42.26

## DENMARK

Tage Olsen A/S  
Ronnegade 1  
Copenhagen 0  
Tel. 29 48 00

## FINLAND

INTO O/Y  
Meritulinkatu 11  
P.O. Box 153  
Helsinki  
Tel. 6 11 33

## FRANCE

Hewlett-Packard France  
150 Boulevard Massena  
Paris 13  
Tel. 707 97 19

Hewlett-Packard France  
2 rue Tete d'Or  
Lyon, 6 - Rhone  
Tel. 52 35 66

## GERMANY

Hewlett-Packard Vertriebs-GmbH  
Kurfürststrasse 95  
Frankfurt a. Main  
Tel. 52 00 36

Hewlett-Packard Vertriebs-GmbH  
Reginfriedstrasse 13, Munich 9  
Tel. 49 51 21

Hewlett-Packard Vertriebs-GmbH  
Beim Strohhause 26/28  
Hamburg 1  
Tel. 24 05 51

Hewlett-Packard Vertriebs-GmbH  
(Technisches Büro)  
Herrenberger Strasse 110  
Böblingen, Württemberg  
Tel. 6971

Hewlett-Packard Vertriebs-GmbH  
Lietzenburger Strasse 30  
1 Berlin W 30  
Tel. 24 86 36

Hewlett-Packard Vertriebs-GmbH  
Achenbachstrasse 15  
4 Dusseldorf 1,  
Tel. 68 52 58

## GREECE

K. Karayannis  
Klaffmonos Square  
Athens 124  
Tel. 230 301

## INDIA

The Scientific Instrument Co., Ltd.  
6, Tej Bahadur Sapru Road  
Allahabad 1  
Tel. 2451

The Scientific Instrument Co., Ltd.  
240, Dr. Dadabhai Naoroji Road  
Bombay 1  
Tel. 26-2642

The Scientific Instrument Co., Ltd.  
11 Esplanade East, Calcutta 1  
Tel. 23-4129

The Scientific Instrument Co., Ltd.  
30 Mount Road, Madras 1  
Tel. 86339

The Scientific Instrument Co., Ltd.  
B-7, Ajmeri Gate Extn.  
New Delhi 1  
Tel. 271053

## IRAN

Telecom, Ltd.  
P.O. Box 1812  
Teheran  
Tel. 43850, 48111

## ISRAEL

Electronics & Engineering Ltd.  
Division of Motorola Israel Ltd.  
16. Kremenetski Street, Tel-Aviv  
Tel. 35021

## ITALY

Hewlett-Packard Italiana S.p.A.  
Viale Lunigiana 46, Milan  
Tel. 69 15 84

Hewlett-Packard Italiana S.p.A.  
Palazzo Italia  
Piazza Marconi 25, Rome-Eur  
Tel. 591 2544

## JAPAN

Yokogawa-Hewlett-Packard Ltd.  
# 59, 1-chome  
Yoyogi  
Shibuya-ku  
Tokyo,  
Tel. 370-2281

Yokogawa-Hewlett-Packard Ltd.  
# 8, Umeda  
Kita-ku, Osaka City  
Tel. 313-0091

Yokogawa-Hewlett-Packard Ltd.  
# 4, 3-chome  
Himekedori  
Chigusa-ku, Nagoya City  
Tel. 751-8545

## KOREA

American Trading Co., Korea, Ltd.  
Seoul P.O. Box 1103  
112-35 Sokong-Dong  
Jung-ku, Seoul  
Tel. 3.7049, 3.7613

## LEBANON

Constantin E. Macridis  
Clemenceau Street  
Clemenceau Center  
Beirut  
Tel. 220846

## NETHERLANDS

Hewlett-Packard Benelux, N.V.  
23 Burg, Roelstraat  
Amsterdam, W.  
Tel. (020) 13 28 98

## NEW ZEALAND

Sample Electronics (N.Z.) Ltd.  
8 Matipo Street  
Onehunga S.E. 5, Auckland  
Tel. 565-361

## NORWAY

Morgenstjerne & Co. A/S  
Ingeniørfirma  
6 Wessels Gate, Oslo  
Tel. 20 16 35

## PAKISTAN

Mushko & Company, Ltd.  
Oosman Chambers  
Victoria Road  
Karachi 3, West Pakistan  
Tel. 54601

Mushko & Company, Ltd.  
Zirat Chambers  
31, Jinnah Avenue  
Dacca, East Pakistan  
Tel. 80058

## PANAMA

Electronico Balboa, S.A.  
P.O. Box 4929  
Panama City  
Tel. 3-0833

## PERU

Fernando Ezeta B  
Av. Petit Thouars 4719  
Mira Flores, Lima  
Tel. 5-0346

## PORTUGAL

Telectra  
Rua Rodrigo da Fonseca 103  
P.O. Box 2531, Lisbon 1  
Tel. 68 60 72

## PUERTO RICO

San Juan Electronics, Inc.  
Ponce de Leon No. 150, Stop 3  
Pta. de Tierra Sta., San Juan  
Tel. 725-3342

## SPAIN

Ataro Ingenieros  
Enrique Laretta 12  
Madrid, 16  
Tel. 235 43 44-5

## SOUTH AFRICA

F.H. Flanter & Co. (Pty.), Ltd.  
Rosella House  
Buitencing1e Street  
Cape Town  
Tel. 3-3817

F.H. Flanter & Co.,(Pty.), Ltd.  
P.O. Box 200, Bramley  
775 Pretoria Main Road  
Wynberg, Transvaal  
Tel. 40-6871

## SWEDEN

HP Instrument AB  
Centralvagen 28  
Solna Centrum  
Tel. 08-83 08 30

HP Instrument AB  
Box 4028  
Indunagatan 28A  
Molndal 4  
Tel. 27 68 00

## SWITZERLAND

Max Paul Frey  
Wankdorffeldstrasse 66  
Berne  
Tel. (031) 42 00 78

## TAIWAN

Hwa Sheng Electronic Co., Ltd.  
P.O. Box 1558  
21 Nanking West Road  
Taipei  
Tel. 46076, 45936

## TURKEY

Telekom Engineering Bureau  
P.O. Box 376 - Galata  
Istanbul  
Tel. 49 40 40

## UNITED KINGDOM

Hewlett-Packard Ltd.  
Dallias Road  
Bedford, England  
Tel. 68052

## VENEZUELA

Citec, C.A.  
Edif. Arisan-Of. No. 4  
Avda. Francisco de Miranda  
Chacarito  
Caracas  
Tel. 71.88.05

## YUGOSLAVIA

Belram S.A.  
83 Avenue des Mimosas  
Brussels 15, Belgium  
Tel. 35 29 58

**For Sales and Service  
Assistance in Areas Not  
Listed Contact:**

## EUROPE

Hewlett-Packard, S.A.  
54 Route des Acacias  
Geneva, Switzerland  
Tel. (022) 42.81.50

## ELSEWHERE

Hewlett-Packard  
1501 Page Mill Road  
Palo Alto, California 94304, U.S.A.  
Tel. (415) 326-7000

# IMPEDANCE OVERLAYS

## INSTRUCTIONS FOR USE

### 50-OHM SYSTEM

#### IMPEDANCE CONVERSION OVERLAYS

#### FOR MODEL 1415A

#### TIME DOMAIN REFLECTOMETER

The enclosed set of CRT overlays may be used with the hp Model 1415A to obtain a direct impedance reading at a specific point on a device or system under test. Proceed as follows:

1. Cut out overlays at circle.
2. Calibrate the Model 1415 according to the procedure outlined in Section III of the Operating and Service Manual.
3. Make required connections and instrument settings. Note setting of the REFL COEFFICIENT control, and select corresponding impedance overlay (the value of  $\rho$ , reflection coefficient, appears at the left edge of the overlay).
4. Place the selected overlay on face of CRT. Use the index marks to position the overlay at center and along the horizontal and vertical axes of the graticule. If necessary, use clear tape to secure the overlay.

#### Note

Values indicated for  $\rho$  and  $Z_L$  have been located on the overlay to compensate for parallax when taking pictures.

5. Position the display with the 50-ohm reference line at the center of the overlay.
6. Note the magnitude of the disturbance on the display and read the impedance value,  $Z_L$ , from the right-hand column on the overlay. The corresponding value of reflection coefficient appears in the left-hand column.

