

As you are now the owner of this document which should have come to you for free, please consider making a donation of £1 or more for the upkeep of the (Radar) website which holds this document. I give my time for free, but it costs me around £300 a year to bring this document to you. You can donate here <https://blunham.com/Radar>, thank you.

Do not upload this copyright pdf document to any other website. Breaching copyright may result in a criminal conviction and large payment for Royalties.

This document was generated by me, Colin Hinson, from a document held at R.A.F. Henlow Signals Museum which is believed to be out of copyright or Crown Copyright. It is presented here (for free) under the Open Government Licence (O.G.L.) if under Crown Copyright and this version of the document is my copyright (along with the Crown Copyright) in much the same way as a photograph would be. It should be noted that most of the pages are identifiable as having been processed by me. If you believe the original document to be under copyright, please contact me.

The document should have been downloaded from my website <https://blunham.com/Radar>, or any mirror site named on that site. If you downloaded it from elsewhere, please let me know (particularly if you were charged for it). You can contact me via my Genuki email page: <https://www.genuki.org.uk/big/eng/YKS/various?recipient=colin>

You may not copy the file for onward transmission of the data nor attempt to make monetary gain by the use of these files. If you want someone else to have a copy of the file, point them at the website (<https://blunham.com/Radar>). Please do not point them at the file itself as it may move or the site may be updated.

I put a lot of time into producing these files which is why you are met with this page when you open the file.

In order to generate this file, I need to scan the pages, split the double pages and remove any edge marks such as punch holes, clean up the pages, set the relevant pages to be all the same size and alignment. I then run Omnipage (OCR) to generate the searchable text and then generate the pdf file.

Hopefully after all that, I end up with a presentable file. If you find missing pages, pages in the wrong order, anything else wrong with the file or simply want to make a comment, please drop me a line (see above).

If you find the file(s) of use to you, you might like to make a donation for the upkeep of the website – see <https://blunham.com/Radar> for a link to do so.

Colin Hinson

In the village of Blunham, Bedfordshire, UK.

**SIGNAL GENERATOR
HEWLETT-PACKARD 8614A**

BY COMMAND OF THE DEFENCE COUNCIL



Ministry of Defence

Sponsored for use in the
ROYAL AIR FORCE by DWSE (RAF)

Publications authority: ATP/MOD (PE)

Service users should send their comments through
the channel prescribed for the purpose in:
A.P.100B-01, Order 0504 (ARMY and RAF)

PREFACE

This Publication was technically accurate at the time of initial printing but differences may be found in instruments containing subsequent design changes and/or other improvements. These differences are listed as "Changes" (e.g. Change 1,2, etc.) together with the Serial No. or Prefix of the applicable instruments, to enable the Publication to be used with instruments updated since the initial printing.

To use this information:

Make all appropriate Serial No. related changes indicated in the table below.

<u>Serial Prefix or Number</u>	<u>Applicable Changes</u>
815-02601 to 815-02850	1
953-02851 to 953-02975	1,2
953-02976 to 953-03025	1 to 3
953-03026 to 953-03475	1 to 4
1111A	1 to 5
1150A	1 to 6

CHANGE 1

Page 5-31/5-32, Fig. 5-26:
Change R700 to 1 Megohm.

CHANGE 2

Page 2-1, para.2-10:

Change the 4th. sentence to read as follows:

A 2-ampere standard fuse is used for 115 volts operation and a 1-ampere fuse is used for 230 volts operation.

Page 5-29/5-30, Fig. 5-25:

Change F1 to 2A, 115VAC, and 1A, 230VAC.

CHANGE 3

Page 5-31/5-32, Fig. 5-26:

Replace the appropriate portions of figure with the attached partial schematic.

CHANGE 4

Not applicable (deleted)

CHANGE 5

Not applicable (deleted)

CHANGE 6

Page 1-1, para. 1-9: Add the following sentence:

Option A85 (light grey panel) and option X95 (complete grey-blue colour scheme) are available to match prior Hewlett-Packard instruments.

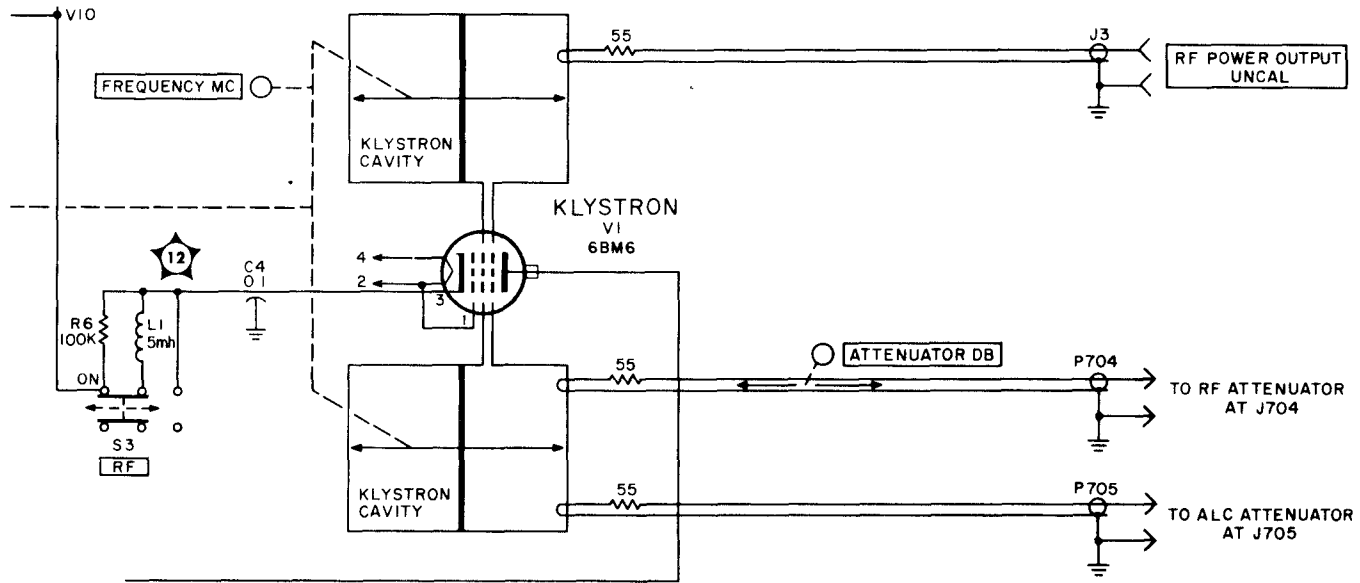

P/O Figure 5-26. Modulation and Klystron Circuits (P/O Change 3)

CONTENTS

PRELIMINARY MATERIAL

Title page
Amendment record sheet
Preface
Contents (this list)

GENERAL AND TECHNICAL INFORMATION (-1)

GENERAL ORDERS AND MODIFICATIONS (-2)

To be issued later

SCALE OF SERVICING SPARES (-3D)

To be issued later

AP 117E-0305-1

**SIGNAL GENERATOR
HEWLETT-PACKARD 8614A**

GENERAL AND TECHNICAL INFORMATION

SIGNAL GENERATOR 8614A

SERIALS PREFIXED: 815- above 02201

This Operating and Service Manual applies to HP 8614A instruments with serial number prefix 815- above 02201.

SERIAL PREFIXES NOT LISTED

For instruments with serial number prefixes 815- below 02201, a "Backdating" Appendix is supplied in the back of this manual.

Copyright HEWLETT-PACKARD COMPANY 1965
1501 PAGE MILL ROAD PALO ALTO, CALIFORNIA, U S A

08614-90001 Printed: MAR 1969

TABLE OF CONTENTS

Section	Page	Section	Page
I GENERAL INFORMATION	1-1	V MAINTENANCE (Cont'd)	
1-1. Introduction	1-1	5-19. Troubleshooting	5-5
1-6. Supplementary Instruments	1-1	5-20. Locating Trouble	5-5
1-9. Instrument Options	1-1	5-24. Power Supply Trouble	5-7
1-11. Instrument Identification	1-1	5-28. Transistor Troubleshooting	5-9
1-13. Klystron Warranty Claim Sheet	1-1	5-30. In-Circuit Testing	5-9
II INSTALLATION	2-1	5-33. Out-of-Circuit Testing	5-9
2-1. Incoming Inspection	2-1	5-35. Etched Circuits	5-9
2-3. Installation	2-1	5-37. Component Replacement	5-10
2-6. Conversion to Rack Mount	2-1	5-40. Transistor Replacement	5-11
2-7. Air Filter Inspection	2-1	5-41. Klystron Replacement	5-11
2-9. Power Requirement	2-1	5-42. Tube Removal	5-11
2-11. Three-Conductor Power Cable	2-1	5-43. Tube Replacement	5-11
2-14. Repackaging for Shipment	2-1	5-44. RF Probe Replacement	5-12
III OPERATION	3-1	5-45. Probe Removal	5-12
3-1. Introduction	3-1	5-46. Probe Replacement	5-13
3-3. Controls and Indicators	3-1	5-47. PIN Modulator Replacement	5-13
3-5. Operating Procedures	3-1	5-48. Modulator Removal	5-13
3-7. Stabilized Source	3-1	5-50. Modulator Replacement	5-14
IV PRINCIPLES OF OPERATION	4-1	5-51. Cam Cable Replacement	5-14
4-1. Introduction	4-1	5-52. Tools Required	5-14
4-3. RF Oscillator	4-1	5-53. Procedure	5-14
4-6. PIN Diode Modulator	4-1	5-55. Adjustments	5-17
4-16. Modulation Circuits	4-2	5-56. Adjustment after Klystron Replacement	5-17
4-18. External Pulse	4-2	5-58. Initial Repeller-Voltage Adjust	5-17
4-20. Internal Square Wave	4-3	5-59. Repeller Mode Adjust	5-17
4-22. Synchronized Square Wave	4-3	5-60. Frequency Range Spread Adjust	5-17
4-24. External AM	4-3	5-61. Power Adjust	5-18
4-28. Internal Meter and Automatic Level Control (ALC)	4-4	5-63. Internal Leveling Adjust	5-19
4-38. External Leveling	4-5	5-65. Adjustments after PIN Modula- tor Replacement	5-21
4-40. Regulated Power Supply	4-5	5-67. Meter Amplifier Adjust	5-21
V MAINTENANCE	5-1	5-68. ALC Amplifier Adjust	5-21
5-1. Introduction	5-1	5-69. On-Off Ratio Adjust	5-21
5-3. Periodic Maintenance	5-1	5-70. Pulse Modulation Adjust	5-21
5-4. Cleaning Air Filter	5-1	5-71. Square-Wave Modulation Adjust	5-21
5-6. Lubrication	5-1	5-72. AM Response Adjust	5-22
5-8. Performance Checks	5-1	5-73. Repeller Pot (R220) Replacement	5-22
5-11. Frequency and Power Check	5-1	5-74. Tools Required	5-22
5-12. Leveled Output Check	5-2	5-75. Procedure	5-22
5-13. On-Off Ratio Check	5-2	5-77. Low Pass Filter Replacement	5-22
5-14. Pulse Modulation Check	5-3	5-78. Tools Required	5-22
5-15. Square-Wave and Sync Check	5-3	5-79. Procedure	5-22
5-16. External AM Check	5-3		
5-17. Measurement of Residual FM	5-4	VI REPLACEABLE PARTS (Deleted)	
5-18. Measurement of Incidental FM	5-4		

Section	Page
APPENDIX	i-1
Manual Changes	i-1

LIST OF ILLUSTRATIONS

Number	Title	Page	Number	Title	Page
1-1.	Model 8614A Signal Generator	1-0	5-5.	Residual and Incidental FM Check	5-5
2-1.	Conversion to Rack Mount	2-0	5-6.	Electrical Adjustment Location	5-7
3-1.	Front and Rear Panel Controls and Indicators	3-0	5-7.	High-Voltage Test Point Location	5-7
3-2.	Unleveled RF Power Output	3-2	5-8.	Transistor Biasing and Amplifier Characteristics	5-8
3-3.	Internally-Leveled RF Output	3-3	5-9.	Klystron Cavity Assembly, Cutaway View	5-12
3-4.	Externally-Leveled RF Power	3-4	5-10.	RF Probe Assembly	5-12B
3-5.	Internal Square-Wave and External Sync	3-5	5-11.	PIN Modulator (External View)	5-14
3-6.	External Pulse Modulation	3-6	5-12.	Cam Assembly	5-14
3-7.	External FM Modulation	3-7	5-13.	Instrument Top View, Cover Removed	5-15
3-8.	External AM Modulation	3-8	5-14.	Repeller Mode Adjust Setup	5-16
4-1.	Circuit Block Diagram	4-1	5-15.	Frequency Range Spread Correction Curve	5-18
4-2.	Simplified Block Diagram of PIN Modulator	4-1	5-16.	Probe Assembly Adjust	5-19
4-3.	Controlled RF Attenuator Unit	4-2	5-17.	Repeller Pot Assembly	5-20
4-4.	Control ALC Attenuator Unit	4-2	5-18.	R220 Repeller Resistor Assembly	5-23
4-5.	Pulse Modulation Circuit	4-3	5-19.	Low Pass Filter Assembly Drawing	5-24
4-6.	Square-Wave Modulation Circuit	4-3	5-20.	Instrument Block Diagram	5-25
4-7.	External AM Circuit	4-4	5-21.	High-Voltage Board (A100)	5-26
4-8.	ALC and Meter Circuit	4-4	5-22.	High-Voltage Power Supply	5-27
4-9.	Series-Regulated Power Supply	4-5	5-23.	ALC Board (A500)	5-29
5-1.	Frequency and Power Measurement	5-1	5-24.	High-Voltage Board (A500)	5-29
5-2.	External Pulse Check	5-2	5-25.	Regulated +20 Volt and Filament Supplies	5-31
5-3.	Internal Square-Wave Check	5-3	5-26.	Modulation and Klystron Circuits	5-33
5-4.	External AM Check	5-4	5-27.	ALC Circuit	5-35

LIST OF TABLES

Number	Title	Page
1-1.	Specifications	1-0
5-1.	Test Equipment Required	5-0
5-2.	Power Supply Troubleshooting	5-6
5-3.	General Trouble Location	5-7
5-4.	Out-of-Circuit Transistor Resistance Measurements	5-10
5-5.	Ohmmeter Ranges for Transistor Resistance Measurements	5-10
5-6.	Etched Circuit Soldering Equipment	5-11
5-7.	Klystron Repeller Voltages	5-17
5-8.	Klystron Probe Adjust	5-19
5-9.	ALC Amplifier Adjust.	5-21



Figure 1-1. Model 8614A Signal Generator

Table 1-1. Specifications

<p>FREQUENCY RANGE: 800 to 2400 MHz; single, linearly calibrated control; direct reading within 2 MHz.</p> <p>VERNIER: ΔF control has a minimum range of 1.0 MHz for fine tuning.</p> <p>FREQUENCY CALIBRATION ACCURACY: ± 5 MHz</p> <p>FREQUENCY STABILITY: Approximately 0.005%/°C change in ambient temperature, less than 2500 Hz peak residual FM, 0.003% change for line voltage variation of $\pm 10\%$.</p> <p>RF OUTPUT POWER: +10 dBm (10 mW) into 50-Ω load. Output attenuation dial directly calibrated in dBm from 0 to -127 dBm. A second uncalibrated output (approximately 0.5 mW) is provided on front panel.</p> <p>RF OUTPUT POWER ACCURACY (with respect to attenuation dial): ± 0.75 dB + attenuator accuracy (0 to -127 dBm) including leveled output variations</p> <p>ATTENUATOR ACCURACY: +0, -3 dB from 0 to -15 dBm; ± 0.2 dB ± 0.06 dB/10 dB from -15 to -127 dBm; direct reading dial, 0.2 dB increments.</p> <p>LEVELED OUTPUT: Over entire frequency range at any attenuation setting below 0 dB: ± 0.75 dB. Output power adjustable with ALC control.</p> <p>INTERNAL IMPEDANCE: 50 Ω; SWR < 2.0</p> <p>MODULATION: On - off ratio at least 20 dB for square wave, pulse</p> <p>INTERNAL SQUARE WAVE: 950 to 1050 Hz. Square wave can be synchronized with a +1 to +10 V signal at PULSE input.</p> <p>EXTERNAL PULSE: 50 Hz to 50 kHz; 2 μsec rise time, +20 to +100 V peak input.</p>	<p>EXTERNAL AM: DC to 1 MHz</p> <p>INCIDENTAL FM: Negligible for power levels below -10 dBm.</p> <p>EXTERNAL FM: Mode width between 3 - dB points varies between a minimum of approximately 4 MHz at a frequency of 800 MHz to a maximum of approximately 15 MHz at 2000 MHz. Sensitivity is approximately 100 kHz/V between 800 and 1600 MHz (1-3/4 mode), and 200 kHz/V between 1600 and 2400 MHz (2-3/4 mode).</p> <p>a) Front panel connector capacity-coupled to repeller of klystron b) Two-terminal rear panel connector (Cinch-Jones type S304AB) is dc-coupled to repeller of klystron.</p> <p>POWER SOURCE: 115 or 230 V $\pm 10\%$, 50 to 60 Hz, approximately 125 W</p> <p>DIMENSIONS:</p> <p>NOTES DIMENSIONS IN INCHES AND (MILLIMETERS) Ⓐ EIA RACK HEIGHT (INCLUDING FILLER STRIP) FOR CABINET HEIGHT (INCLUDING FEET) ADD 5/8 (8) TO EIA RACK HEIGHT Ⓑ REAR APRON RECESS</p>
--	---

WEIGHT: Net 48 lb (22 kg); shipping approximately 52 lb 11 oz (24 kg)

SECTION I

GENERAL INFORMATION

1-1. INTRODUCTION.

1-2. The Model 8614A Signal Generator provides RF power in the 800- to 2400-MHz range and produces an RF power output of at least 10 milliwatts. Output frequency and attenuation are read directly on digital dials, and fine frequency changes can be made by means of the front-panel ΔF control. Complete specifications are given in Table 1-1. The 8614A is shown in Figure 1-1.

1-3. The instrument has two power output connectors which supply RF power simultaneously. One output provides at least 10 milliwatts of power and may be leveled. When in the leveled output mode of operation and the output is 0 dBm or less, the RF output is held quite constant across the band without resetting the attenuator or power monitor. The other output connector provides an uncalibrated output of at least 0.5 milliwatt. A waveguide-beyond-cutoff attenuator, which is referenced to the RF output, accurately attenuates the calibrated RF power output from 0 to -127 dBm.

1-4. RF power output can be internally square-wave modulated. In addition, the RF power can be externally AM, FM, or pulse modulated. An external ALC (automatic level control) input which can be used for remote leveling loop control and an external dc-coupled FM input which can be used for external AFC is also provided.

1-5. PIN diode attenuators are used for leveling, square wave, pulse, and amplitude modulation. The PIN attenuator is an absorption device that can be electrically controlled to attenuate RF power. A sampling loop which includes a PIN diode attenuator compensates for changes in RF power output to hold the RF power output nearly constant.

1-6. SUPPLEMENTARY INSTRUMENTS.

1-7. Two instruments capable of extending the operating parameters of the generator are the HP Model 8403A (option 02) and the Model 2650A. The option 02 Model 8403A Modulator produces output pulses with 30 - nanosecond rise and 20 - nanosecond decay time characteristics and has an 80-dB on-off ratio. Pulse

outputs are accurately variable in frequency, width, and delay. Amplitude modulation is available with frequency responses to 10 MHz for sine waves. Square-wave frequency capability is accurately available. The modulator also provides sync and delayed-sync outputs.

1-8. The Model 2650A oscillator synchronizer may be used directly to stabilize all internal cavity reflex klystron signal generators. Short-term stability is one part in 10^8 /sec, and long-term stability is one part in 10^6 /week over 0 to 50 degrees centigrade.

1-9. INSTRUMENT OPTIONS.

1-10. In addition to the standard instrument, the option 01 is available. The option 01 instrument has its input connectors located on both the front and rear panel and its output connectors located on the rear panel; in all other respects it is the same as the regular signal generator.

1-11. INSTRUMENT IDENTIFICATION.

1-12. Hewlett-Packard uses a two-section, eight-digit serial number (on instrument rear panel) to identify instruments (000-00000). The first three digits are a serial prefix number, and the last five digits refer to a specific instrument. If the serial prefix on your instrument does not appear on the title page of this manual, there are differences between the manual and your instrument which are described in the Appendix or in a Manual Change Sheet included with the manual. If the change sheet is missing, the information can be supplied by your local sales office.

1-13. KLYSTRON WARRANTY CLAIM SHEET.

1-14. The klystron supplied and replacement klystrons purchased from the Hewlett-Packard Company are guaranteed by the manufacturer against electrical failure for a specified period of time (time from date of purchase or hours of operation); warranty conditions vary with the type of tube used. Thus, for the actual warranty period of the klystron in your instrument, contact your local sales office. A sheet for your use is included in the appendix of this manual; follow the instructions on the sheet explicitly.

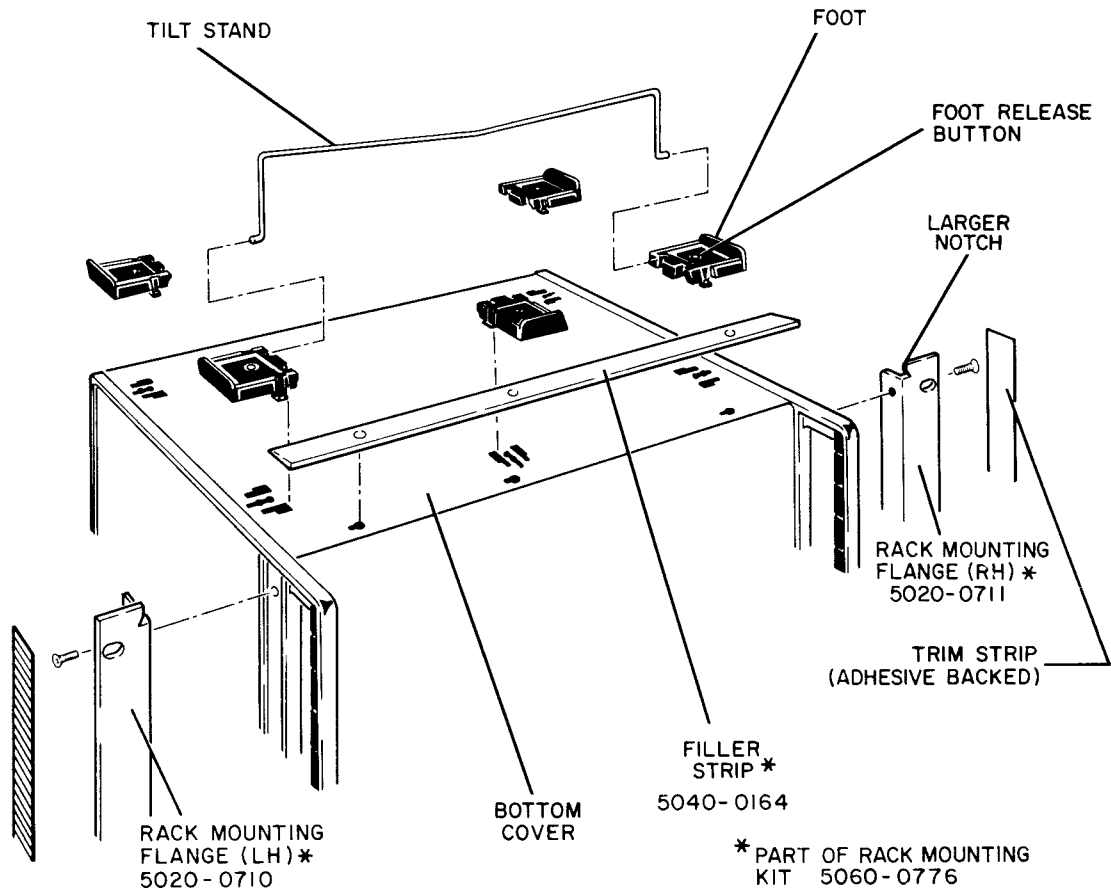

Figure 2-1. Conversion to Rack Mount

SECTION II INSTALLATION

2-1. INCOMING INSPECTION.

2-2. This instrument was inspected both mechanically and electrically before shipment. To confirm this, the instrument should be inspected for physical damage in transit. Also check for supplied accessories, and test the electrical performance of the instrument, using the procedure outlined in paragraph 5-8. If there is damage or deficiency, see the warranty on the inside rear cover of this manual.

2-3. INSTALLATION.

2-4. The Model 8614A is delivered as a cabinet mount instrument. A kit is supplied with the instrument for conversion from cabinet to rack mount.

Note

This instrument is electrostatically shielded but not magnetically shielded. Hence, a magnetic field near the top or bottom covers can cause excessive incidental FM in the output signal. To eliminate this problem a metal shield, such as a sheet of silicon steel, must be placed between the 8614A and any magnetic field.

2-5. Whether the instrument is cabinet- or rack-mounted, provision should be made for adequate circulation of air around the instrument. The instrument cooling fan is located at the rear of the instrument and louvers are located on instrument side panels. Proper air circulation is most important at the sides and rear of the instrument.

CAUTION

IF FAN IS NOT OPERATING, THE INSTRUMENT SHOULD NOT BE OPERATED.

2-6. CONVERSION TO RACK MOUNT.

a. Remove trim strip on sides of instrument (refer to Figure 2-1).

b. Remove tilt stand by pressing two sides of stand toward center of instrument and lifting it out.

c. Remove five feet at bottom of instrument. Press button in center of each foot, slide them toward center of instrument, and lift out.

d. Place rack mounting flanges (two) where trim strips were and secure with screws provided.

e. Add filler strip to bottom of instrument.

f. Rack mounting under severe vibration conditions must be supplemented with additional support at rear.

2-7. AIR FILTER INSPECTION.

2-8. The Model 8614A uses forced-air cooling to maintain tolerable temperature within the instrument. Incoming air is filtered through a special filter at the rear of the instrument. The air filter should be checked periodically and if dirty, cleaned. Refer to paragraph 5-4 for air filter maintenance.

2-9. POWER REQUIREMENT.

2-10. The Model 8614A can be operated from a 115- or 230-volt, 50- to 60-Hz source. A two-position slide switch (LINE VOLTAGE) at the rear of the instrument selects ac operation mode. The line voltage at which the instrument is set to operate appears on the slider of the switch. A 1-1/2-ampere standard fuse is used for 115-volt operation; a 3/4-ampere standard fuse is used for 230-volt operation.

2-11. THREE-CONDUCTOR POWER CABLE.

2-12. To protect operating personnel, the National Electrical Manufacturer's Association (NEMA) recommends that the instrument panel and cabinet be grounded. This instrument is equipped with a three-conductor power cable which, when plugged into an appropriate receptacle, grounds the instrument. The offset pin on the power cable three-prong connector is the ground wire.

2-13. To preserve the protection feature when operating the instrument from a two-contact outlet, use a three-prong to two-prong adapter and connect the green pigtail on the adapter to ground.

2-14. REPACKAGING FOR SHIPMENT.

2-15. The following list is a general guide for repackaging an instrument for shipment. However, if you have any questions, contact your local sales and service office (see lists at rear of manual).

a. If possible, use the original container designed for the instrument. If a carton and packing materials are desired, they can be ordered from your local sales and service office.

b. The instrument is supported by four polyethylene supports fitted to the instrument height: one support located at each corner.

Note

If the instrument is to be shipped to the Hewlett-Packard Company for service or repair, attach to the instrument a tag identifying the instrument by owner, model, and full serial number, and indicating the service or repair to be accomplished. In any correspondence, refer to the instrument by model number and complete serial number including the three-digit prefix.

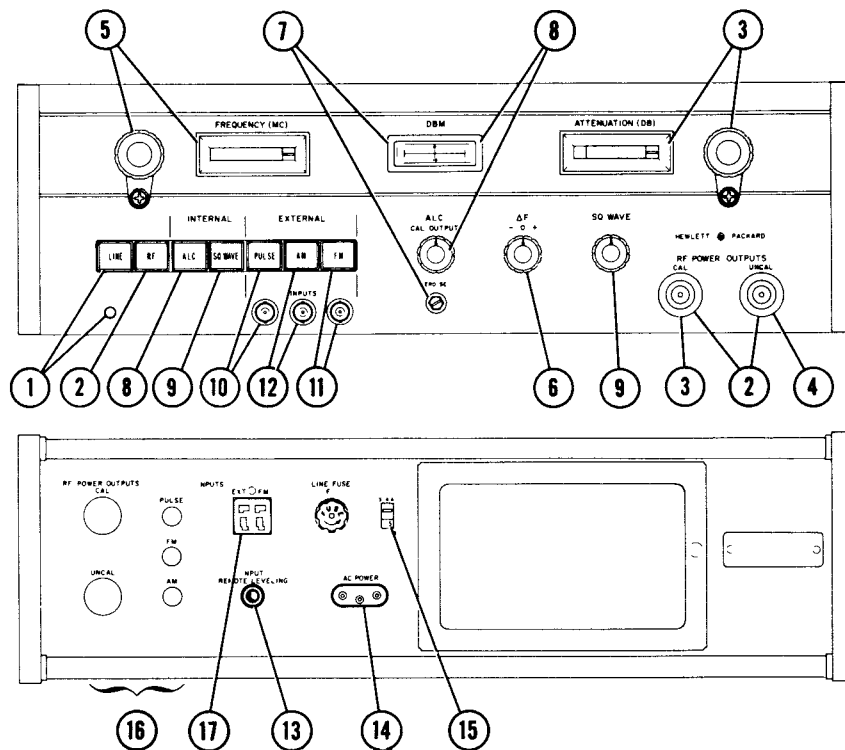

1. LINE. Connects primary power to instrument; lamp glows.
2. RF. Applies power to RF POWER OUTPUTS.
3. ATTENUATION (DB). Sets RF power level at the CAL RF POWER OUTPUT.
4. UNCAL RF POWER OUTPUT. Provides approximately 0.5 mW unlevelled and unattenuated RF power.
5. FREQUENCY (MC). Sets RF frequency.
6. ΔF . Permits small deviations from FREQUENCY (MC) setting (± 1.5 MHz minimum).
7. ZERO SET. Adjust for zero indication on DBM meter (with RF turned off).
8. ALC. Levels calibrated RF output; used to set a reference on DBM meter.
9. INTERNAL SQ WAVE. Modulates CAL RF OUTPUT. SQ WAVE control adjusts modulation frequency.
10. EXTERNAL PULSE. Positive pulses to external pulse input will provide modulation voltages required to pulse modulate CAL RF OUTPUT. Positive pulses turn RF "ON".
11. EXTERNAL FM. AC voltages applied to external FM input will provide frequency modulation of both CAL and UNCAL outputs.
12. EXTERNAL AM. Signals applied to external AM input will provide modulation voltages required to AM-modulate CAL RF OUTPUT.
13. INPUT REMOTE LEVELING. Input jack for external leveling loop voltage applied to level generator CAL RF POWER OUTPUT.
14. POWER. Male receptacle which connects to the power cord.
15. LINE VOLTAGE. Arranges input power transformer to accept either 115- or 230-volt, 50- to 60-Hz primary power input.
16. OPTION 01. Input and output connectors located on rear panel (input connectors also located on front panel).
17. EXT FM. Two terminal connector dc-coupled to klystron for stabilization of output frequency.

Figure 3-1. Front and Rear Panel Controls and Indicators

SECTION III OPERATION

3-1. INTRODUCTION.

3-2. The Model 8614A can provide 1.0 milliwatt of leveled power across its frequency range (RF outputs leveled to within ± 0.5 dB can be obtained across the band for attenuator setting of 0 dB or less). Output power can be attenuated to -127 dB. When operating unleveled, attenuation reference is the klystron power output; when operating leveled, attenuation reference is output reference setting. Internal square-wave modulation is available from 950 to 1050 Hz. External FM, AM, and pulse modulation voltages also can be used. Two or three modulation modes of operation can be applied to the instrument simultaneously; push-button controls select the mode of operation. External modulation signal inputs are located directly below the modulation button to which they apply.

CAUTION

RF power in excess of approximately 125 mW should never be applied to RF power output connectors as internal damage could result.

3-3. CONTROLS AND INDICATORS.

3-4. Front and rear panel controls and connectors are shown in Figure 3-1. Each control and connector is identified with a numbered callout, and an explanation of the function, given in the accompanying text, is keyed to the callout number.

3-5. OPERATING PROCEDURES.

3-6. The operating procedures (Figures 3-2 through 3-8) give step-by-step procedures for the various modes of operation. Instructions are given for obtaining the following leveled and unleveled outputs: CW,

square-wave modulated (modulating voltage supplied internally), and FM, AM, and pulse-modulated (modulating voltage supplied externally). Steps of each procedure are numbered according to the sequence in which they are to be performed, and any control or connector used is identified with the number of the step in which it is used.

Note

A magnetic field near the 8614A can cause excessive incidental FM in the output signal. A strong field can cut off the RF output. To eliminate the problem, place a sheet of high permeability metal, such as silicon steel, between the 8614A and radiation source.

3-7. STABILIZED SOURCE.

3-8. To use the 2650A Oscillator Synchronizer with the signal generator, proceed as follows:

a. The rear panel connector EXT FM (J201) is a Cinch-Jones type S304AB. Connection between this jack and J5 of the 2650A must be made as follows:

Pin 3, J201, to Pin E, J5 - 2650A

Pin 4, J201, to Pin F, J5 - 2650A

Pin 1, J201, to Pin G, J5 - 2650A

Pin 2, J201, no connection.

b. Connect RF output from UNCAL OUTPUT connector on Model 8614A to OSCILLATOR INPUT connector on Model 2650A. Depress EXTERNAL FM button on Model 8614A and proceed as explained in the instruction manual for the Model 2650A.

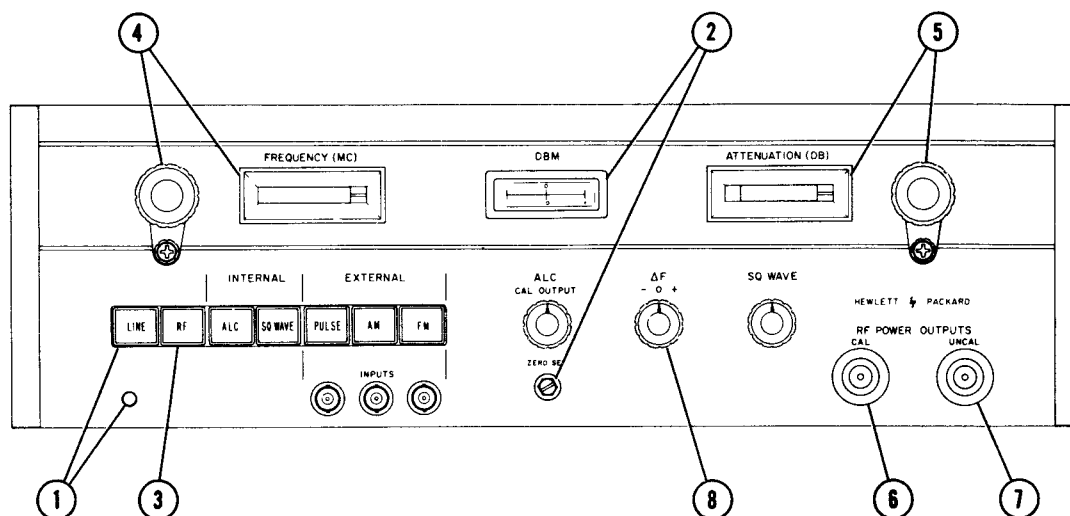

1. Depress LINE; lamp glows, indicating heater and high voltage are applied.
2. Note meter pointer on DBM meter.
3. Depress RF; there should be some deflection of DBM meter pointer.

Note

When RF button is depressed, meter pointer will fluctuate from approximately +1 dBm at low frequency to +4 dBm or more at high frequency.

4. Set FREQUENCY (MC) to desired frequency.

5. The ATTENUATION(DB) knob will attenuate RF power at CAL RF POWER OUTPUT. Counterclockwise rotation will increase output power, although fully counterclockwise rotation will cause output power to decrease.
6. Take unlevelled but attenuable RF power at CAL RF POWER OUTPUT.
7. Take unlevelled and unattenuable RF power at UNCAL RF POWER OUTPUT.
8. For maximum output at the CAL RF POWER OUTPUT, adjust ATTENUATION (DB) and ΔF controls together and monitor output with a power meter. Note: changing ΔF setting will also change frequency.

Figure 3-2. Unlevelled RF Power Output

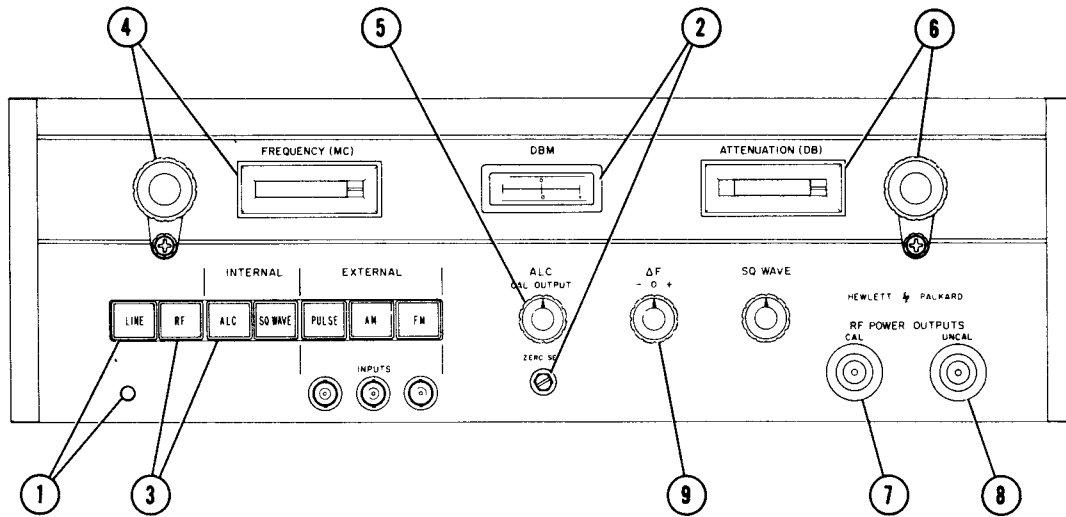

1. Depress **LINE**.
2. Check that meter pointer on **DBM** meter is on **ZERO SET** mark; if not, adjust accordingly.
3. Depress **RF** and **INTERNAL ALC**; there should be some deflection of **DBM** meter pointer.
4. Set **FREQUENCY (MC)** for 800 MHz.
5. Adjust **ALC CAL OUTPUT** for desired dbm reference on **DBM** meter. The **ALC** system holds **RF** output power across the band to within ± 0.75 dB for levels of 0 dBm or less. The most common **DBM** meter reference is 0 so that the attenuated **RF** output power can be read directly from attenuator readout. Note: the **ATTENUATION (DB)** will not accurately calibrate above -15 dB.

Note

- Power may be leveled above 0 dBm over that portion of the band where the desired power is available.
6. Set **ATTENUATION (DB)** to desired attenuation. The **RF** power level at **CAL RF POWER OUTPUT** is the algebraic sum of the **DBM** meter setting and of the **ATTENUATION (DB)** setting.
 7. Take leveled and attenuable **RF** power available at **CAL RF POWER OUTPUT**.
 8. Take unleveled and unattenuable **RF** power at **UNCAL RF POWER OUTPUT**.
 9. ΔF control should be centered.

Figure 3-3. Internally-Leveled RF Output

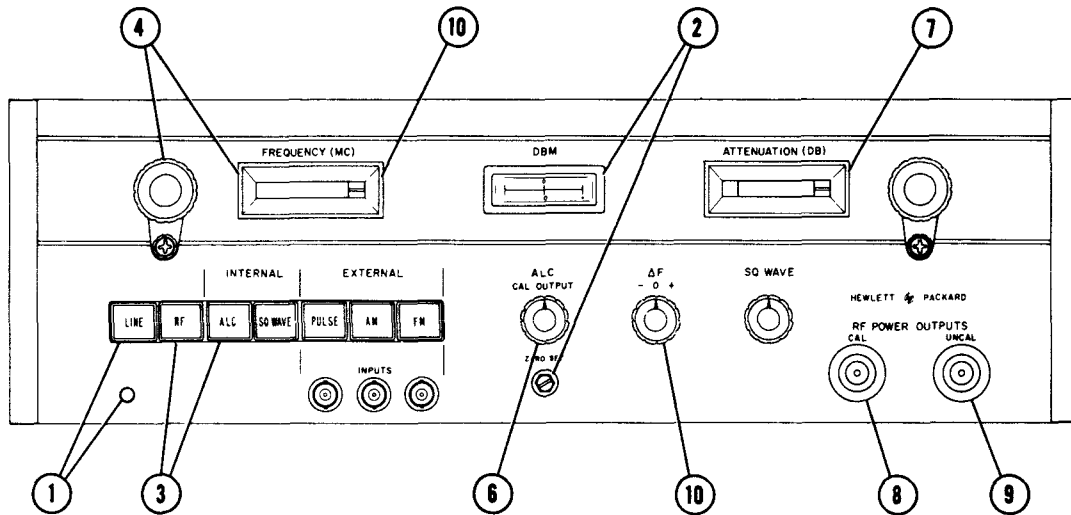

1. Depress LINE.
2. Check that meter pointer on DBM meter is on ZERO SET mark.
3. Depress RF and INTERNAL ALC.
4. Set FREQUENCY (MC) for 800 MHz.
5. With a directional coupler connected between CAL output and the load, and as close to the load as possible, sample and detect incident power and apply the detected signal to INPUT REMOVE LEVELING phone jack connection (rear panel). Adjust ATTENUATION (DB) control for detected 40 to 240 mV signal. Note: ATTENUATION (DB) control cannot be adjusted fully counterclockwise or loading effects will appear at higher frequencies.
6. Adjust ALC CAL OUTPUT for desired reference on DBM meter. This reference point may vary from that used with internal leveling due to different detector sensitivities.
7. Do not change ATTENUATION (DB) setting once leveling loop is set up. Adjusting attenuator position may degrade leveling loop operation.
8. Take leveled and attenuable RF power available at CAL RF POWER OUTPUT.
9. Take unleveled and unattenuable RF power at UNCAL RF POWER OUTPUT.
10. ΔF control should be centered when not in use.

Figure 3-4. Externally-Leveled RF Power

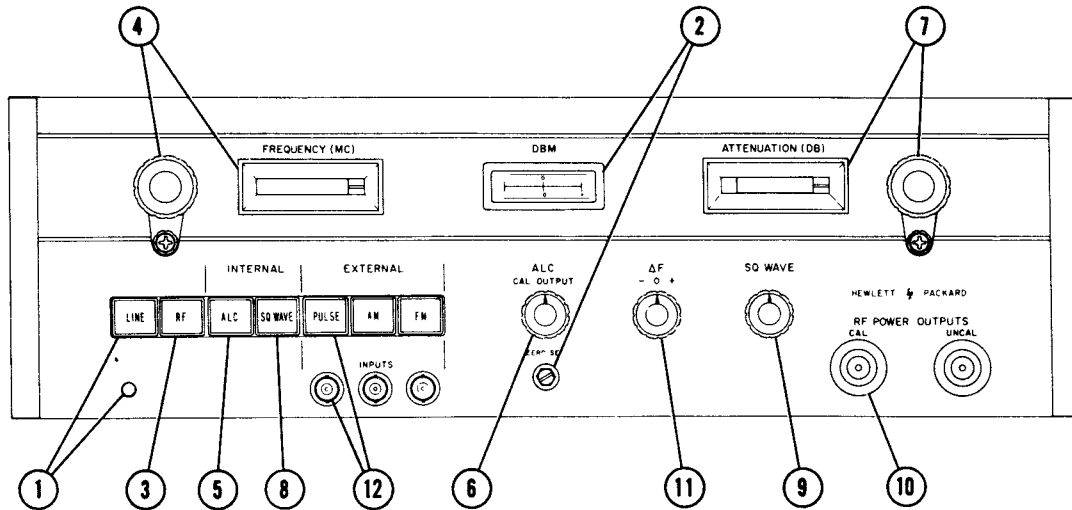

1. Depress LINE.

Note

When unleveled power is to be modulated, omit steps 2, 5, and 6.

2. Check that meter pointer on DBM meter is on ZERO SET mark.
3. Depress RF.
4. Set FREQUENCY (MC).
5. Depress INTERNAL ALC.
6. Adjust ALC CAL OUTPUT for 0 dBm reference on DBM meter.
7. Set ATTENUATION (DB).
8. Depress SQ WAVE.
9. Adjust SQ WAVE for desired modulation frequency.
10. Take leveled and attenuable RF power output at CAL RF POWER OUTPUT.
11. The ΔF control may be adjusted for small changes in RF frequency and to peak maximum output power. However, adjusting too far from centered position will cause RF power to decrease and, if in leveled operation, poor leveling.
12. EXTERNAL SYNCHRONIZATION.
 - a. Depress PULSE and apply +1 to +10 V pulse.
 - b. Pulse repetition rate must be equal to desired square wave frequency (950-1050 Hz).
 - c. Decrease SQ WAVE frequency to a rate slightly slower than the-pulse repetition rate.

Figure 3-5. Internal Square-Wave Modulation and External Sync

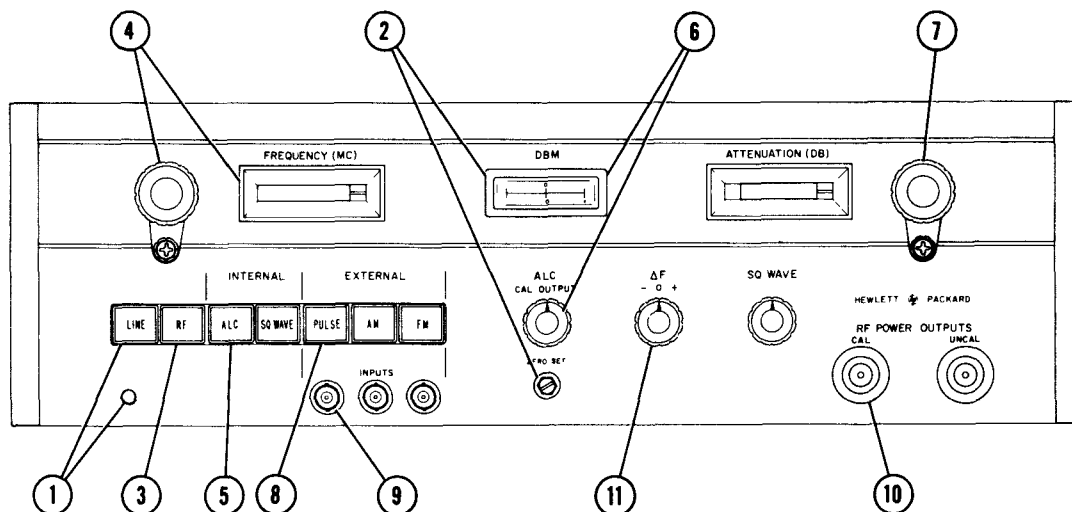

1. Depress LINE.

Note

If external pulse modulation of unlevelled power is desired, omit steps 2, 5, and 6.

2. Check that meter pointer on DBM meter is on ZERO SET mark.
3. Depress RF.
4. Set FREQUENCY (MC).
5. Depress INTERNAL ALC.
6. Adjust ALC CAL OUTPUT for 0 dBm reference on DBM meter.

7. Set ATTENUATION (DB) as desired.

8. Depress EXTERNAL PULSE.

9. Apply 20- to 100-volt 50-Hz to 50-kHz positive pulse modulating signal to EXTERNAL PULSE INPUT.

10. Take leveled and attenuable pulse modulated RF power output at CAL RF POWER OUTPUT.

11. The ΔF control may be adjusted for small changes in RF frequency and to peak maximum output power. However, adjusting too far from centered position will cause RF power to decrease and, if in leveled operation, poor leveling.

Figure 3-6. External Pulse Modulation

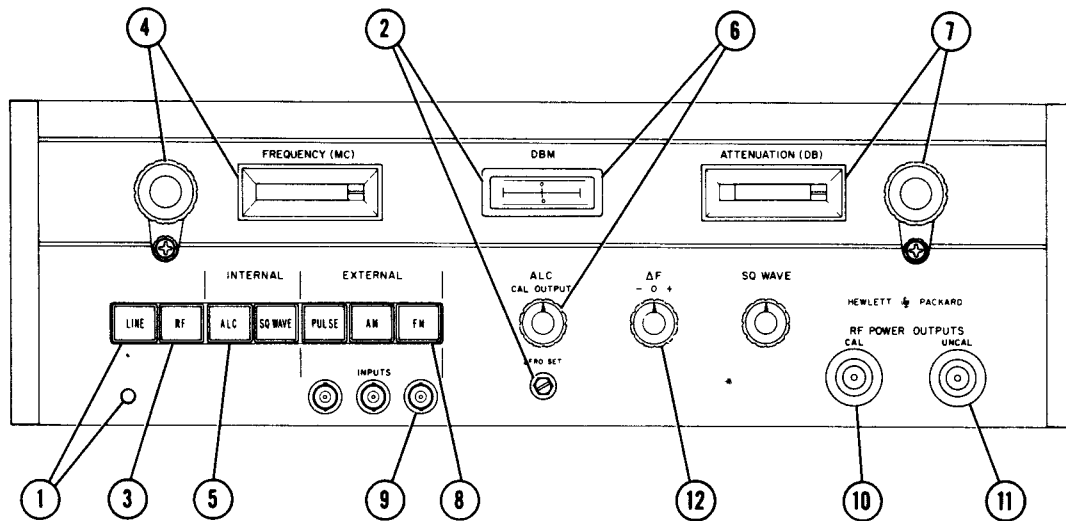

1. Depress LINE.

Note

If external FM modulation of unleveled power is desired, omit steps 2, 5, and 6.

2. Check that meter pointer on DBM meter is on ZERO SET mark.
3. Depress RF.
4. Set FREQUENCY (MC).
5. Depress INTERNAL (ALC).
6. Adjust ALC CAL OUTPUT for 0 DBM meter reference. A 0 DBM reference allows a direct readout of ATTENUATION (DB) dial. The ALC system will level RF power with FM frequencies of 1 kHz or less and typically (depending upon individual klystron sensitivity) with FM voltage amplitudes of 40 volts or less between 800 and 1600 MHz and 60 to 75 V between 1600 and 2400 MHz.

Note

Power may be leveled above 0 dBm over that portion of the band where the desired power is available.

7. Set ATTENUATION (DB).
8. Depress EXTERNAL FM.
9. Apply modulating signal to EXTERNAL FM INPUT (front or rear panel).
10. Take leveled and attenuable frequency modulated RF power output at CAL RF POWER OUTPUT.
11. Take unleveled FM-modulated RF power at UNCAL RF POWER OUTPUT.
12. ΔF control should be centered so that the klystron will operate in the center of the mode.

Figure 3-7. External FM Modulation

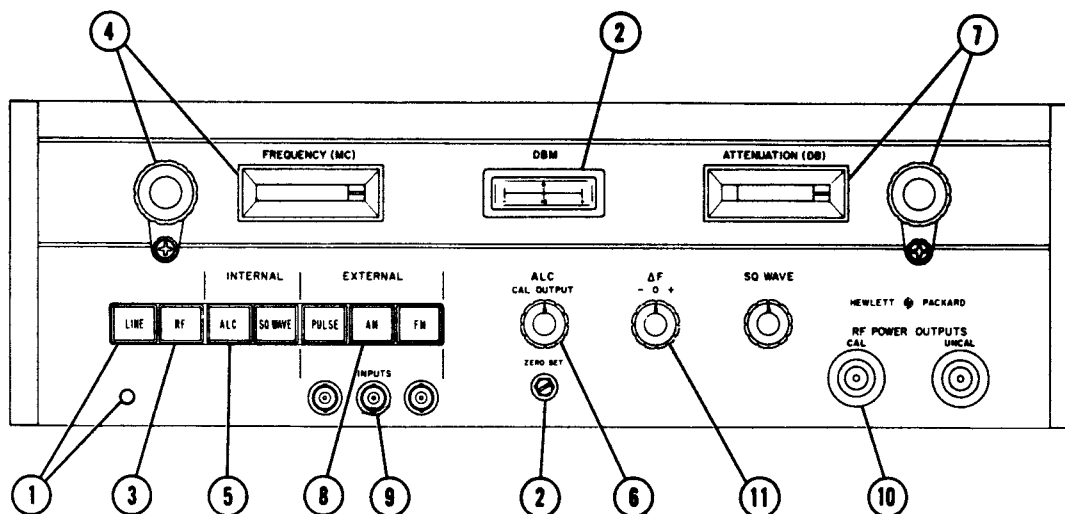

1. Depress LINE.
2. Check that meter pointer on DBM meter is on ZERO SET mark.
3. Depress RF.
4. Set FREQUENCY (MC).

Note

The modulator used is an absorption-type. If leveling mode of operation is not used, the positive portions of AM modulating signal will be clipped.

5. Depress INTERNAL ALC.
6. Adjust ALC CAL OUTPUT control for a -3 dBm reference on DBM meter. A -3 dBm reference on the DBM meter is the most common used because this allows the AM signal to modulate the RF up to 3 dB above the output level.

7. Set ATTENUATION (DB) to 000 or less; re-check DBM meter.
8. Depress AM button.
9. Apply AM modulating signal to external AM INPUT (5 to 6 volts peak).
10. Modulated signal available at CAL RF OUTPUT only.
11. The ΔF control may be adjusted for small changes in RF frequency and to peak maximum output power. However, adjusting too far from centered position will cause RF power to decrease and, if in leveled operation, poor leveling.

Figure 3-8. External AM Modulation

SECTION IV PRINCIPLES OF OPERATION

4-1. INTRODUCTION.

4-2. Basically the instrument includes an RF Oscillator, PIN Diode Modulator, Automatic Leveling Circuit, Modulation Circuits, and Power Supply as shown in Figure 4-1. The RF Oscillator is a reflex klystron which always operates CW. The PIN diode modulator is a current-controlled device that attenuates RF power up to 20 dB or more. The control circuits provide the modulation currents required by the PIN modulator. The power supply provides the regulated dc voltages required to operate the circuits in the instrument.

4-3. RF OSCILLATOR.

4-4. The RF Oscillator, providing the RF power, consists of a velocity-modulated tube operating in an external resonant cavity. The tube is a reflex klystron operating in the 1-3/4 and 2-3/4 repeller modes.

4-5. The RF power output from the oscillator, which may be CW or CW with FM, is obtained from the resonant cavity by means of pickup probes located in small sections of waveguide which open into the resonant cavity. One of these probes delivers RF power directly to the UNCALIBRATED RF OUTPUT connector, the other two deliver RF power to the PIN modulator.

4-6. PIN DIODE MODULATOR.

4-7. The PIN modulator, which is two nearly identical units in one, is a high-speed, current-controlled absorption-type attenuator. The Modulator is shown in Figure 5-11. A simplified illustration of the modulator is shown in Figure 4-2. Each PIN diode unit includes a transmission line, PIN diodes, low-pass filter, and two high-pass filters.

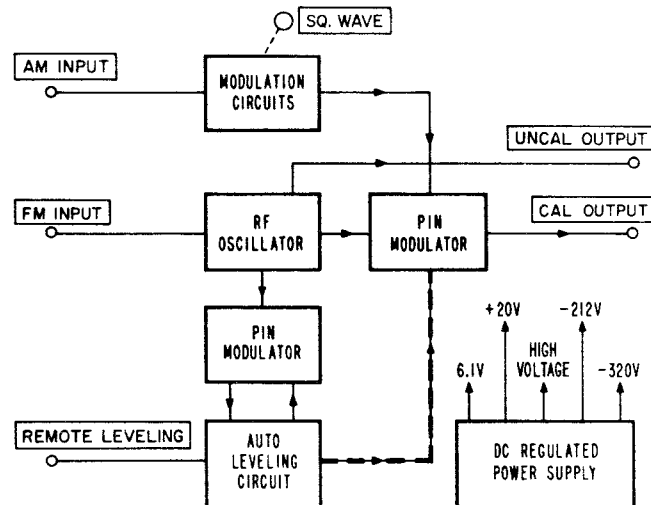

Figure 4-1. Circuit Block Diagram

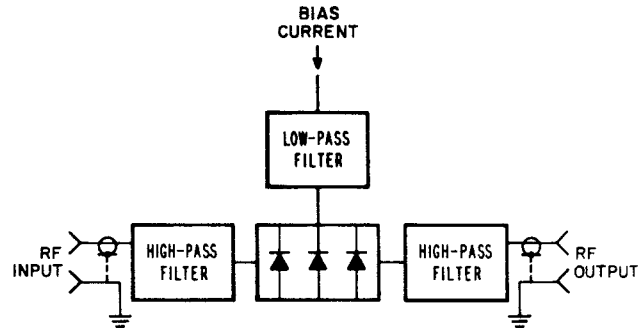

Figure 4-2. Simplified Block Diagram of PIN Modulator

4-8. The PIN diode is a slice of nearly pure silicon wafer in which the P and N traces are nearly equal. P-type impurities are diffused from one side into the wafer, and N-type impurities are diffused from the other side, leaving a layer of intrinsic semiconductor (silicon) through the middle; thus the name PIN diode. At frequencies below 100 MHz the PIN diode rectifies the same as any other good junction diode. However, at frequencies above 100 MHz, rectification efficiency drops rapidly because of carrier storage in the intrinsic (I) layer.

4-9. When forward-bias current flows through the PIN diode, holes and electrons are stored in the I layer. The more the bias current, the larger the amount of stored charge-carriers. When reverse bias is applied, reverse current flows until the stored carriers are depleted. During this period, the diode impedance remains low. Currents above several hundred megacycles do not flow in the reverse direction for a long enough time to remove those charge carriers. Therefore, microwave currents do not significantly change the instantaneous amount of charge carriers stored, and there is negligible rectification.

4-10. There is, however, a resistance to microwave current flow. This resistance is inversely proportional to the number of charge carriers stored in the I layer, and the number of charge carriers, in turn, is proportional to the forward bias current. By varying the bias on a diode from back bias (no stored charge) to about 1/2 mA forward bias, the resistance to microwave currents varies from approximately 5000 ohms to 30 ohms.

4-11. PIN DIODES MOUNTED IN A TRANSMISSION LINE. To understand how a PIN diode modulator works, consider a PIN diode mounted across a transmission line that has a characteristic impedance of 50 ohms. When the diode is back-biased to about 5000 ohms, the microwave signal on the transmission line is unattenuated because 5000 ohms compared to 50-ohm line

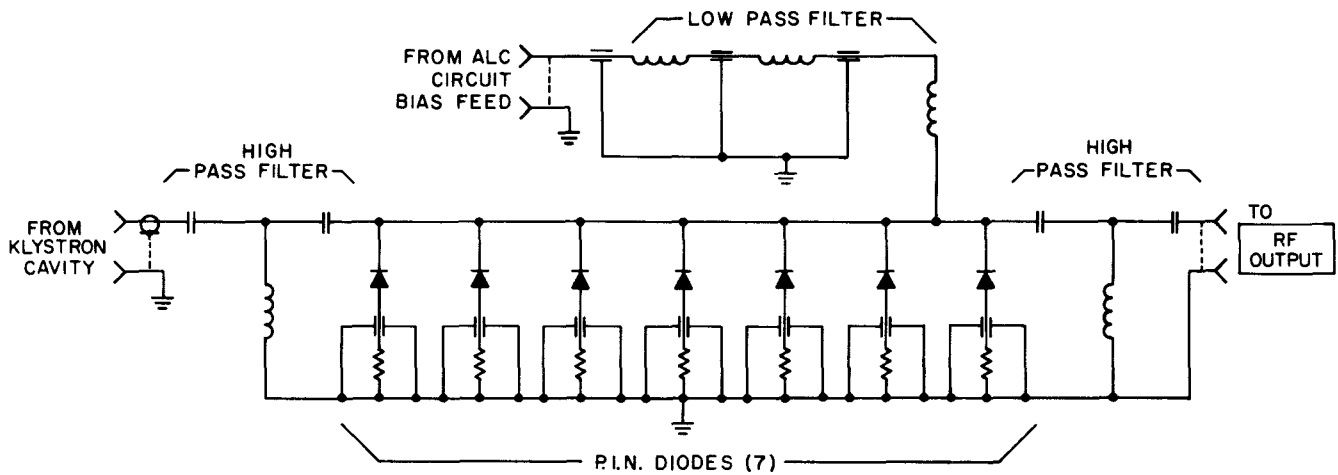

Figure 4-3. Controlled RF Attenuator Unit

impedance has little effect. However, when the diode is forward-biased to about 30 ohms, most of the microwave current will flow through the 30-ohm diode instead of propagating down the 50-ohm transmission line. This current through the 30-ohm diode represents microwave energy dissipated as heat. Consequently, the diode actually absorbs microwave energy.

4-12. Figures 4-3 and 4-4 show the schematic of the PIN diode modulator used in the Model 8614A. The PIN modulator contains seven PIN diodes which are placed at approximately 1/4 wavelength along each strip transmission line. The 1/4 wavelength at mid-band spacing results in the lowest average SWR because reflection from one diode will tend to be absorbed and cancelled by the adjacent diode. The resistance in series with the diodes reduces voltage to the diodes and thereby protects the circuit.

4-13. Modulation input in the form of diode bias is used to change attenuation of the PIN diodes. Changes in diode bias produce changes in RF output level.

4-14. Modulation circuits external to the PIN modulator are protected by a low-pass filter (Figures 4-3 and 4-4) which prevents RF leakage. Leakage, if

present, could cause erratic action in the circuits driving the PIN modulator and could also cause RF interference.

4-15. The high-pass filters (Figures 4-3 and 4-4) permit RF energy to enter and leave the diode strip line while keeping the low frequency modulating signals from entering the RF circuits preceding or following the PIN modulator.

4-16. MODULATION CIRCUITS.

4-17. The basic function of the modulating circuit is to provide the forward- or reverse-bias to the RF PIN attenuator unit. The arrangement of the modulation circuit depends upon the mode of operation. The mode of operation is selected by depressing the appropriate front-panel button.

4-18. EXTERNAL PULSE.

4-19. A simplified diagram of the circuits used in the external pulse mode of operation is shown in Figure 4-5. When the pulse button is depressed, V401A is cut off, and V401B is conducting. The conducting of V401B draws current through the PIN diodes in the RF attenuator unit; hence, conduction of V401B forward-

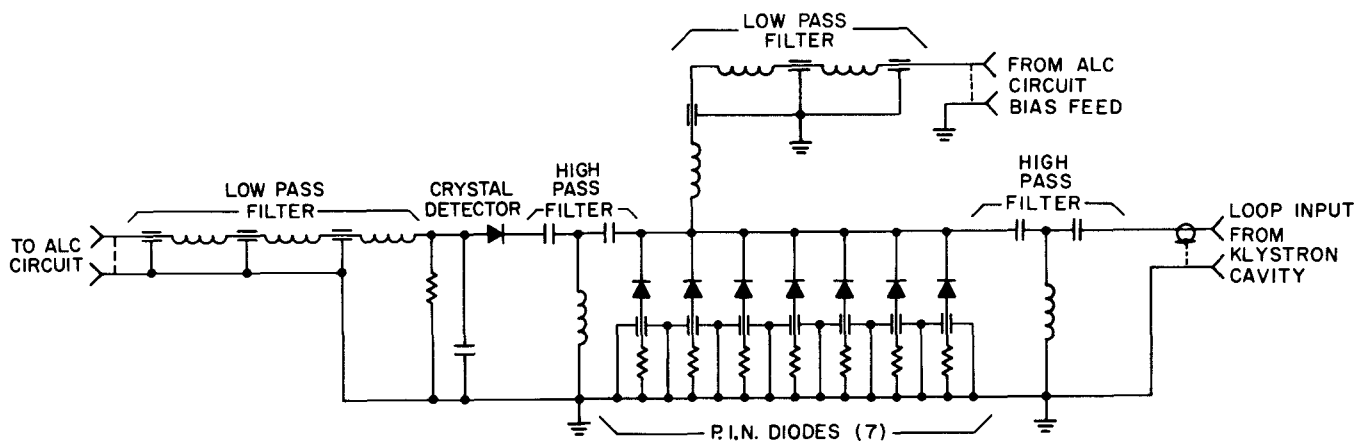

Figure 4-4. Control ALC Attenuator Unit

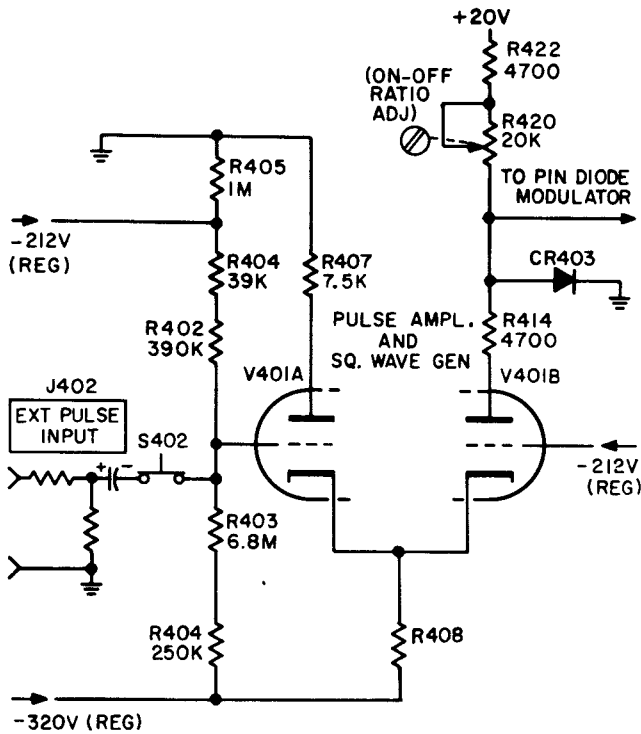

Figure 4-5. Pulse Modulation Circuit

biases the PIN diodes causing the RF output to decrease by more than 20 dB. A positive pulse applied to the external pulse input turns V401A on, turns V401B off, and allows RF power to pass through the PIN diode attenuator with the RF output level clamped to a set level by CR403. The amount of bias applied to the PIN diodes is limited by R420. Resistor R422 prevents the +20 volt supply from shorting to ground through CR403 when resistance of R420 is minimum.

4-20. INTERNAL SQUARE WAVE.

4-21. A simplified diagram of the circuits used in the internal square wave mode of operation is shown in Figure 4-6. When V401B is conducting, capacitor C402 is discharging toward approximately -200 volts while holding V401A cut off. When C402 discharges sufficiently, V401A begins to conduct and biases V401B off through the common cathode resistor R408. This results in C402 charging toward approximately -225 volts as long as V401A conducts. When C402 charges sufficiently, however, the current in V401A becomes limited and V401B again conducts causing V401A to cut off. The RC time constant of C402 is varied by R413, allowing frequency to be changed from 950 to 1050 Hz. When V401B is conducting the RF output is cut off by the PIN diodes. The symmetry of the square wave is adjusted by R410. R410 varies the voltage difference across C402; by varying R410, the time for C402 to charge or discharge to a given potential is controlled.

4-22. SYNCHRONIZED SQUARE WAVE.

4-23. With SQ WAVE and PULSE depressed and no signal applied to the pulse input, operation is as described in paragraph 4-21. When a positive pulse

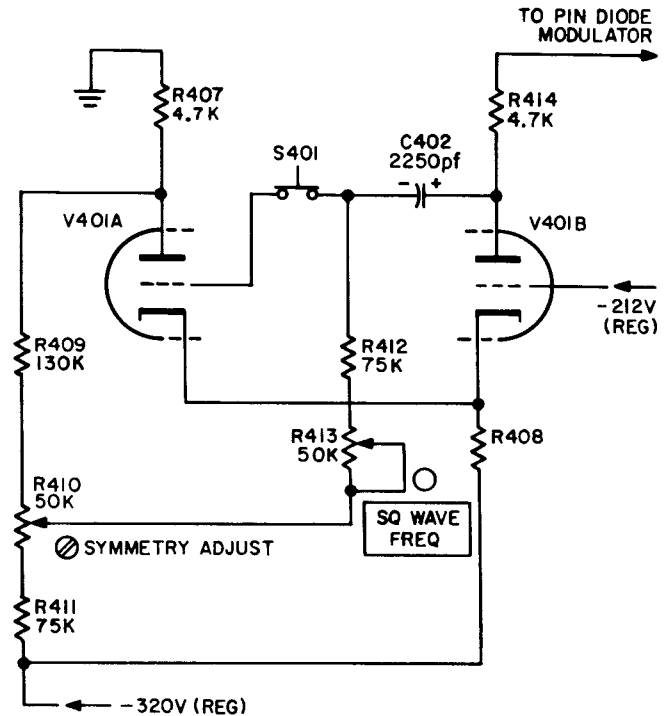

Figure 4-6. Square-Wave Modulation Circuit

signal of at least 1 volt is applied through CR405, the cathode of V401A goes positive, limiting tube current. With limited current, V401B begins to conduct causing the RF output to cut off. Any input signal applied while V401B is conducting will not affect normal square wave circuit operation. Square-wave frequency may be synchronized to any pulse repetition rate between about 955 to 1050 Hz providing internal square-wave frequency is set to a slightly slower rate.

4-24. EXTERNAL AM.

4-25. A simplified diagram of the circuit used in the external AM mode is shown in Figure 4-7. With the AM button depressed, diode CR403 conducts clamping the voltage at the junction of R420 and R419 to about +0.6 volts. This back-biases CR404 which causes current to flow through R419 and R418. When an applied signal goes positive, it reduces the bias current, through R419 and R418, to the controlled RF PIN modulator. Reduced bias current increases the back bias on the PIN diodes which allows more RF power to pass through the PIN modulator. A negative signal increases the bias current which increases the forward bias which causes increased attenuation of RF power through the PIN modulator (up to about 20 dB maximum attenuation depending on the amplitude of the negative half cycle of the AM signal).

4-26. Since the PIN modulator is an absorption-type attenuator, it is necessary to lower the unmodulated RF output power level by an amount equal to the peak level of the AM signal so that the positive peaks will not be clipped. To do this the instrument must be operated in the leveled mode of operation so that the ALC CAL CONTROL can be used to set the RF carrier power level.

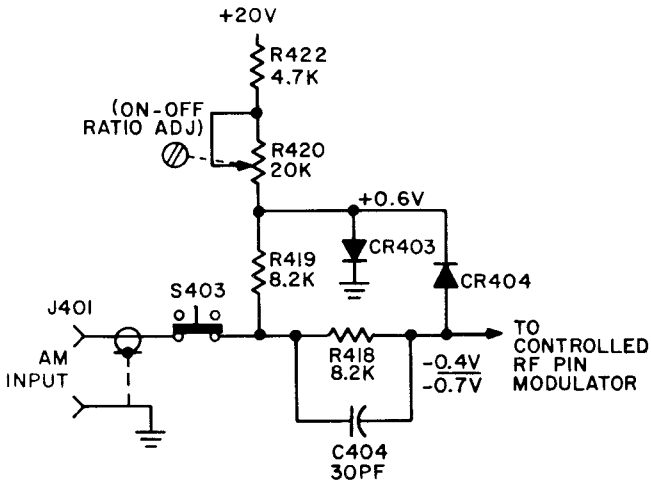

Figure 4-7. External AM Circuit

4-27. For most purposes a signal level reduction of up to 20 dB should be sufficient since it approximates 100% modulation. The amount of distortion is dependent upon the percentage of modulation: at 30% modulation the amount of distortion is almost unnoticeable; at 100% modulation the distortion may be 5 to 20%.

4-28. INTERNAL METER AND AUTOMATIC LEVEL CONTROL (ALC).

4-29. A simplified diagram of the ALC circuit is shown in Figure 4-8. The meter amplifier is a dual function circuit, performing both a leveling and/or a power output monitoring function. RF power is taken from the klystron cavity through the ALC attenuator assembly (part of the PIN diode modulator) and delivered to the ALC circuit. The meter amplifier monitors the power level and in leveled operation with the ALC amplifier, maintains a constant RF output.

4-30. Actual operation is as follows: RF power from the klystron is coupled from a fixed probe in the klystron cavity to the ALC attenuator (part of the PIN diode modulator). The RF power is delivered through a high-pass filter to the ALC diode attenuator, then through another high-pass filter to a crystal detector. The detected signal from CR701 is then delivered to a low-pass filter and to the ALC circuit.

4-31. The crystal detector CR701 is arranged so that the detected signal is negative in polarity. An increase in RF level as the klystron is tuned across the band will cause a more negative output. A decrease in RF power from the klystron causes a less negative output. The detected RF output level from CR701 is then delivered to the base of Q501A.

4-32. Consider the circuit operation when the RF level from the klystron increases. An increase in klystron output level causes a more negative signal on the base of Q501A. The conduction of Q501A decreases causing the collector of Q501A to go in a positive direction. The positive signal goes through the cathode follower, V401, and is applied to the base of Q502, decreasing the conduction of Q502. The collector of Q502 goes more negative.

4-33. A portion of the negative-going signal from the collector of Q502 is applied to the base of Q501B as negative feedback. The feedback factor is determined by the ratio of R513 to R514. The open loop gain of the meter amplifier (Q501A/B, Q502, and Q503) is sufficiently high so that the closed loop gain is essentially a function of the feedback factor and is, therefore, less dependent upon the normal aging effects on the tubes and transistors in the circuit.

4-34. The negative-going signal from Q502 is also applied to the meter M501 for output indication. The meter is protected against overload by the breakdown

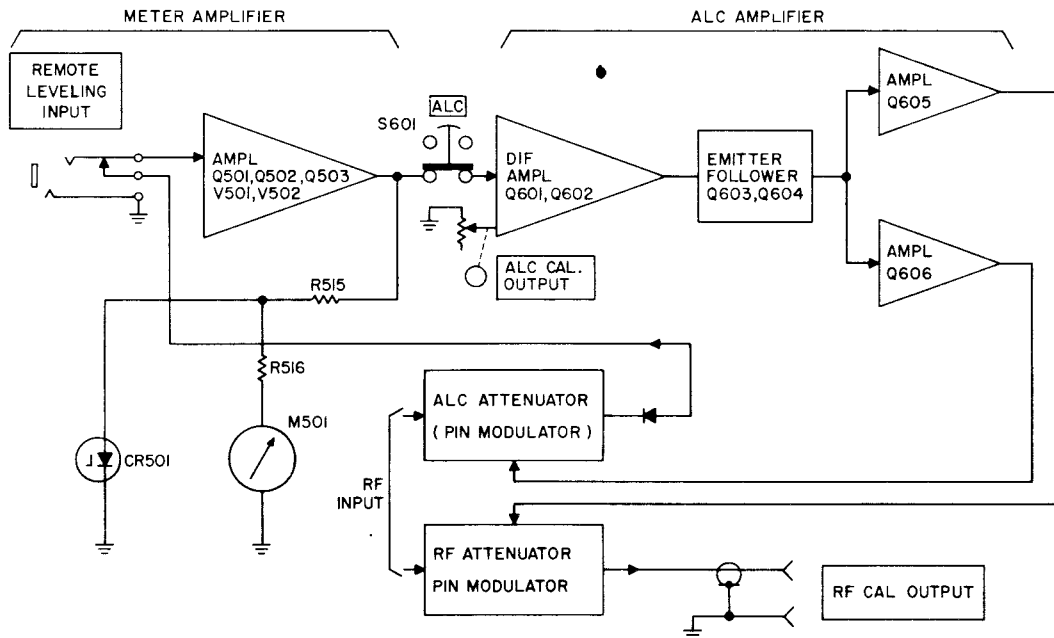

Figure 4-8. ALC and Meter Circuit

diode CR501. If the internal ALC switch, S601, is on, the negative-going output is applied to the base of the differential amplifier, Q601, causing a decrease in conduction. The collector of Q601 will go more positive, causing an increase in conduction of the emitter followers, Q603 and Q604. This causes the emitter of Q604 to also become more positive. The positive-going signal is applied to the bases of Q605 and Q606 increasing their conduction and causing both collectors to become more negative.

4-35. The collectors of Q605 and Q606 appear as constant current sources, so the decrease in collector potential causes current to be drawn from the PIN diodes. This increased bias current (increased forward bias) reduces the RF power output to its original level. The negative-going output from Q605 is delivered to the RF PIN diode attenuator allowing less RF to pass through it also. The net result is that an increase in klystron output causes an increase of forward bias on the PIN diodes which decreases the RF output.

4-36. **LEVELING ACCURACY.** For accurate leveling, the ALC and RF PIN diode attenuators must track together as far as attenuation and frequency are concerned. The adjustment of R614, R615, R620, and R621 provide for matching the attenuator characteristics.

4-37. **ALC CAL OUTPUT.** The RF OUTPUT can be controlled by adjusting the front panel ALC CAL OUTPUT control which varies the bias on the base of the differential amplifier, Q602, which in turn changes the bias on the PIN diode attenuator.

4-38. EXTERNAL LEVELING.

4-39. A simplified diagram of the ALC circuit is shown in Figure 4-8. Operation of the external leveling is the same as that described for internal leveling except that the ALC Attenuator and Q606 are no longer a part of the circuit. Also, the meter M501 does not accurately indicate RF output. If the RF output is to

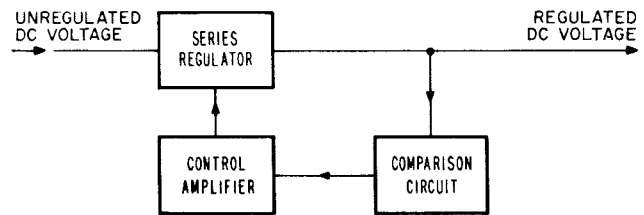

Figure 4-9. Series-Regulated Power Supply

be changed, an external attenuator must be used once leveling is set up.

4-40. REGULATED POWER SUPPLY.

4-41. There are three regulated power supplies: high voltage, +20 volt, and filament. All three supplies are series-regulated types. The series regulator is connected in series with the main load. The output voltage is monitored and compared to a reference voltage. The voltage differential is applied through a control amplifier to the series regulator. This differential voltage changes the effective resistance of the series regulator which in turn holds the output voltage constant (see Figure 4-9).

4-42. The high-voltage supply consists of two supplies which have been combined to obtain required voltages. They are a -320 volt supply on which a -350 volt supply has been stacked to provide a total of -670 volts. Both supplies use voltage doublers to drive series regulator circuits. Since this is a combined circuit arrangement, the -320 volt and -350 volt supplies are interdependent. There is also a gas regulator tube, V105, connected to the -320 volt supply to provide a -212 volt regulated source.

4-43. There are two low-voltage supplies. One provides +20 volts dc for the ALC circuit, the other 6.1 volts dc for filament operation. The +20 volt supply uses a voltage doubler and series regulator, while the filament supply uses a half-wave rectifier and a series regulator.

Table 5-1. Test Equipment Required

Instrument Type	Check	Critical Specifications	Recommended Instrument
Oscilloscope	Calibration Troubleshooting Performance	Frequency Response: > 1 MHz Range: 30 to 0.5 μ s/cm Sensitivity: 0.005 to 1.0 V/cm Accuracy: $\pm 3\%$	HP Model 140A with HP 1422A and HP 1402
Crystal Detector	Calibration Troubleshooting Performance	Frequency Range: 800 to 2400 MHz Sensitivity: 100 mV/0.35 mW Frequency Response: ± 0.5 dB	HP Model 423A
Power Meter	Calibration Performance	Power Range: 0.1 to 10 mW Frequency Range: 800 to 2400 MHz Accuracy: $\pm 3\%$	HP Model 431C Power Meter with HP Model 478A Thermistor Mount
DC Voltmeter	Calibration Troubleshooting	Range: 1 to 685V Accuracy: $\pm 0.2\%$ of reading Floating Input: May operate within ± 470 Vdc of chassis ground	HP Model 3440A Digital DC Voltmeter
AC Voltmeter	Calibration Troubleshooting	Range: 0 to 20 mV Accuracy: $\pm 2\%$ of reading Floating Input: May operate within ± 470 Vdc of chassis ground	HP Model 403B
Clip-On Milliammeter	Calibration Troubleshooting	Range: 0 to 35 mA Accuracy: $3\% \pm 0.1$ mA	HP Model 428A
Ohmmeter	Troubleshooting	Range: 1 to 100 M ohm Accuracy: $\pm 5\%$ of full scale	HP Model 412A
Calibrated Frequency Meter	Calibration Performance	Range: 800 to 2400 MHz Accuracy: 0.03%	HP Model 536A* (1000 to 4100 MHz) PRD 587A (800 to 1000 MHz)*
Pulse Generator	Calibration Performance	Pulse Width: 3 μ s Pulse Rep Rate: 50 to 50 kHz Output: 27 V peak	HP Model 214A
FM Monitor	Performance	Range: 800 to 2400 MHz Accuracy: $\pm 1\%$	HP Model 2590A
FM Modulator	Calibration	Outputs: 300 V peak-to-peak and 6.3 Vac Input: 115 Vac, 60 Hz Phase Adjustable: Approx 80°	Power Transformer (1) (9100-0045) Capacitors (2) (0140-0003) Potentiometers (2) (2100-0047) Fuseholder, extractor post type (1) (1400-0084) Power Cord (1) (8120-0050) Fuse (1) Amp, 115V, Slo Blow (2110-0007)
DC Power Supply	Troubleshooting	Output: 315 to 353 Vdc Ripple: Less than 3 mV	HP Model 711A
Test Oscillator	Calibration Check	Frequency Range: 10 kHz Output: 5 to 6 V peak Output Impedance: 50 ohm	HP Model 651B
Electronic Counter	Calibration Check	Compatible with Transfer Oscillator	HP Model 5245L
Transfer Oscillator	Calibration Check	Frequency Range: 90 MHz Harmonic: 20	HP Model 5257A
Frequency Meter	Calibration Check	Frequency Range: 10 kHz Output: 1 V	HP Model 5210A
Ohmmeter	Troubleshooting	Range: .02 to 500 megohms Accuracy: $\pm 3\%$ of full scale	HP Model 410B
Attenuator	--	10 dB, Fixed	HP Model 8491A

*Frequency Meters are not accurate enough and must be calibrated every 200 MHz across band from 800 to 2400 MHz.

SECTION V MAINTENANCE

5-1. INTRODUCTION.

5-2. This section provides instructions for performance testing, calibrating, troubleshooting, and re-pairing the signal generator. If the serial prefix (the first three numbers of the serial number) of your instrument is different than that listed on the title page of this manual, differences exist between your instrument and the instrument described in this section (refer to the Appendix for difference information).

5-3. PERIODIC MAINTENANCE.

5-4. CLEANING AIR FILTER.

5-5. Inspect the air filter regularly and, if necessary, remove and wash in detergent and water. Dry filter and replace: no oiling or coating of filter is necessary. Unrestricted air flow gives longest component life. Keep the filter clean.

5-6. LUBRICATION.

5-7. No routine lubrication is needed. Lubricate mechanical parts (e.g., dial drive, klystron cavity carriage assemblies) only when necessary using light machine oil on shafts and light grease on gears.

5-8. PERFORMANCE CHECKS.

5-9. **PURPOSE.** The procedures of paragraphs 5-10 through 5-18 check signal generator performance for incoming inspection, periodic evaluation, calibration, and troubleshooting. The tests can be performed without access to the signal generator interior. The specifications of Table 1-1 are the performance standards.

5-10. **TEST EQUIPMENT REQUIRED.** The test instruments required to make the performance checks

are listed in Table 5-1. Test instruments other than the ones listed may be used provided their performance equals or exceeds the Critical Specifications.

5-11. FREQUENCY AND POWER CHECK.

a. Connect equipment as shown in Figure 5-1.

- b. Set up Signal Source as follows:
- | | |
|-------------------------|-----------|
| LINE | depressed |
| RF | depressed |
| ΔF | centered |
| FREQUENCY(MC) | 800 |

c. Set Power Meter for a mid-scale reading.

d. Using calibrated frequency meter, measure actual signal frequency. Specification: accuracy must be ± 5 MHz. **Note:** Frequency meter must be calibrated to an accuracy of approximately $\pm 0.03\%$.

e. Repeat above procedure every 200 MHz and at all points of particular interest to a frequency dial indication of 2400 MHz.

f. If dial accuracy is not within specification, refer to paragraph 5-60 for adjustment procedure.

g. To check power output: Remove frequency meter from test setup and measure maximum power output at both CAL and UNCAL RF OUTPUT connectors. Specification: The sum of attenuation of 10-dB attenuator plus power meter reading must be at least +10 dbm at CAL RF OUTPUT. The attenuator attenuation and meter reading must equal at least -3.0 dBm at UNCAL RF OUTPUT. If either output is not satisfactory, refer to paragraphs 5-59 and 5-61.

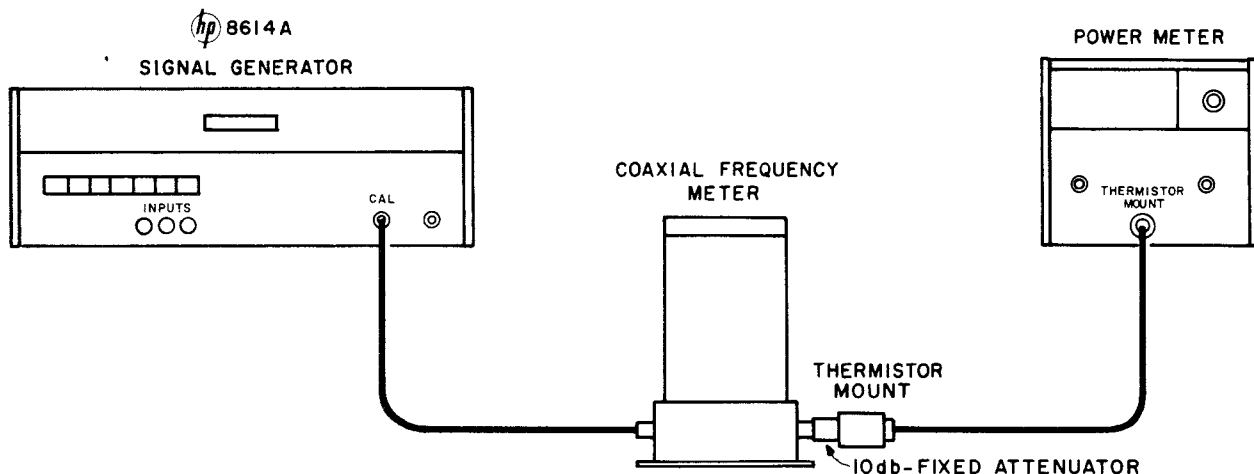

Figure 5-1. Frequency and Power Measurement

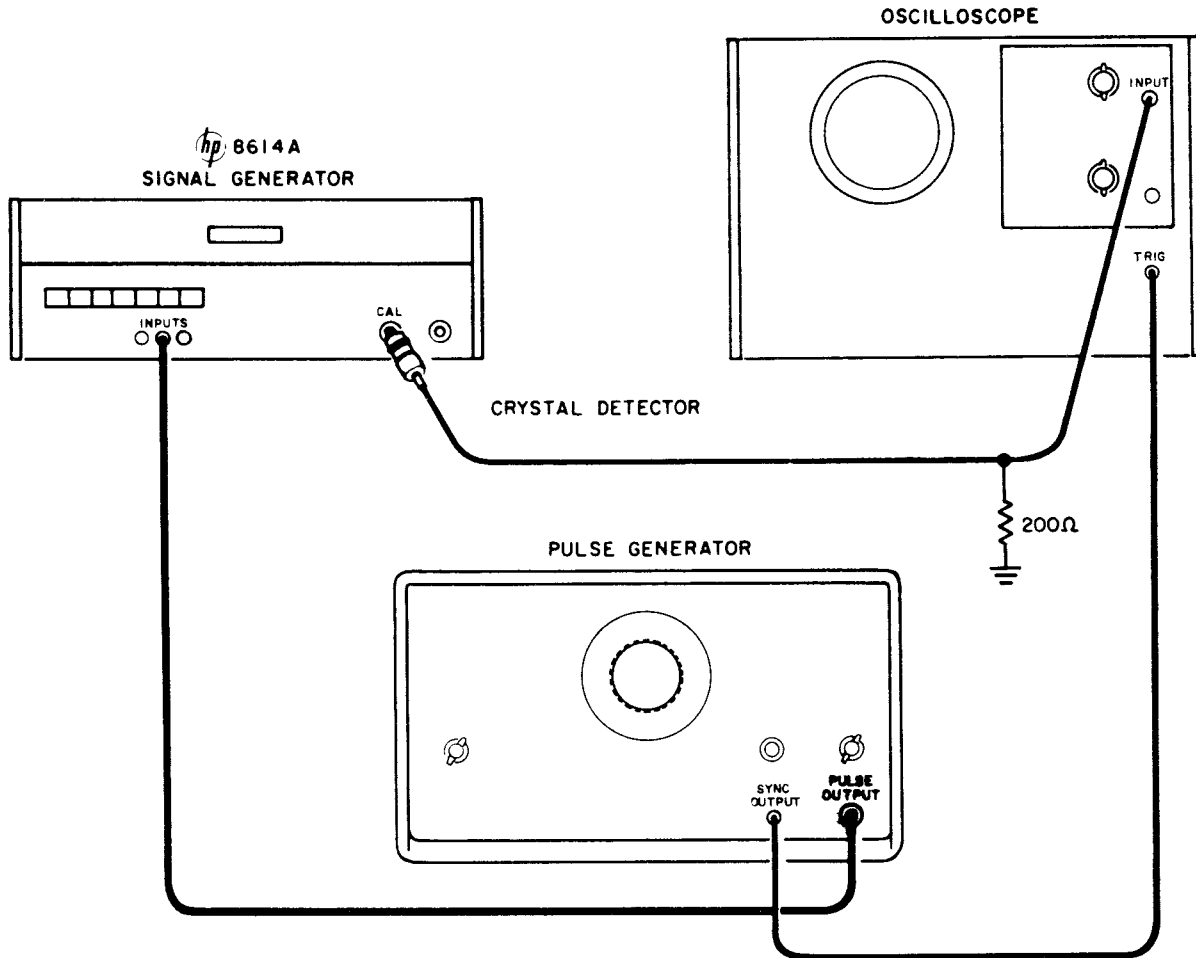

Figure 5-2. External Pulse Check

5-12. LEVELED OUTPUT CHECK.

a. Connect instruments as shown in Figure 5-1, omitting the frequency meter.

- b. Set up Model 8614A as follows:
- | | |
|--------------------------|------------------|
| LINE | depressed |
| RF | depressed |
| FREQUENCY(MC) | 800 MC |
| ALC | depressed |
| ALC CAL OUTPUT | counterclockwise |
| ΔF | centered |

Note

Before ALC button is depressed, DBM meter should indicate approximately +1 dBm; depressing ALC button should cause DBM meter indication to decrease. ALC CAL OUTPUT: 0 dBm (DBM meter indication); ATTENUATOR (DB): -0 dB or less.

- c. Set power meter for mid-scale reading.
- d. Noting power meter variation from setting (step c), tune Model 8614A across frequency band. The variation should not exceed ±0.75 dB.

e. If ALC operation is not satisfactory, refer to paragraph 5-65.

5-13. ON-OFF RATIO CHECK.

a. Connect instruments as shown in Figure 5-1, omitting the frequency meter and attenuator.

- b. Set up Model 8614A as follows:
- | | |
|--------------------------|---------------|
| LINE | depressed |
| RF | depressed |
| FREQUENCY(MC). | 2400 |
| EXTERNAL PULSE | not depressed |
| ATTENUATION(DB). | 000 |
| ALC | depressed |
| ΔF | centered |

c. Set power meter on 0 DBM scale and adjust Model 8614A for convenient reference.

d. Depress EXTERNAL PULSE on Model 8614A.

e. Reference on the power meter should change to the -20 DBM scale. Specification: On-off ratio must be at least 20 dB.

f. If on-off ratio is not at least 20 dB, refer to paragraph 5-69.

5-14. PULSE MODULATION CHECK.

a. Connect instruments as shown in Figure 5-2.

Note

Oscilloscope vertical input should be shunted with 200-ohm resistor.

b. Set up Model 8614A as follows:

- LINE depressed
- RF depressed
- EXT PULSE depressed
- Δ F centered

c. Set up pulse generator for a +20 volt 50-prf signal with a pulse width of 4 μsec.

d. A pulse presentation should be seen on the oscilloscope. Specification: Rise Time, 2 μsec.

e. Set up pulse generator for a +20 volt 5000-prf signal with a pulse width of 4 μsec.

f. A pulse presentation should be seen on the oscilloscope. Specification: Rise Time, 2 μsec.

g. If pulse operation is not satisfactory, refer to paragraph 5-70.

d. Readjust rate control to display one complete square wave on oscilloscope. Square wave symmetry should be better than 45/55%. Range should be at least 950 to 1050 Hz. If square wave operation is not satisfactory, refer to paragraph 5-71.

e. To check external synchronization, connect equipment as shown in Figure 5-2.

f. With Model 8614A set up as detailed in step b above, set pulse generator as follows:

- AMPLITUDE 2.0
- LENGTH (μSEC) 1
- SYNC SELECTOR X10
- PULSE RATE 100
- POLARITY (+)

g. Set oscilloscope to INT TRIGGER SOURCE and adjust SQ WAVE FREQ for a period of 1 ±0.02 ms.

h. Set oscilloscope to EXT AC TRIGGER INPUT and depress PULSE button. Slowly increase PULSE RATE of pulse generator until square wave presentation on oscilloscope becomes stationary. If synchronization operation is not satisfactory, refer to paragraph 4-22.

5-15. SQUARE-WAVE AND SYNC CHECK.

a. Connect instruments as shown in Figure 5-3 (see Note, paragraph 5-14, step a).

b. Set up Model 8614A as follows:

- LINE depressed
- RF depressed
- SQ WAVE depressed
- ATTENUATION(DB) 0 DB
- SQ WAVE FREQ full counterclockwise
- Δ F centered

c. Set oscilloscope sweep time to .1 MHz/CM.

5-16. EXTERNAL AM CHECK.

a. Connect instruments as shown in Figure 5-4 (see Note, paragraph 5-14, step a).

b. Set up Model 8614A as follows:

- LINE depressed
- RF depressed
- AM depressed
- ALC depressed
- ALC CAL OUTPUT -3 DBM (DBM Meter)
- FREQUENCY (MC) 800
- ATTENUATION (DB) 000 or less
- Δ F centered

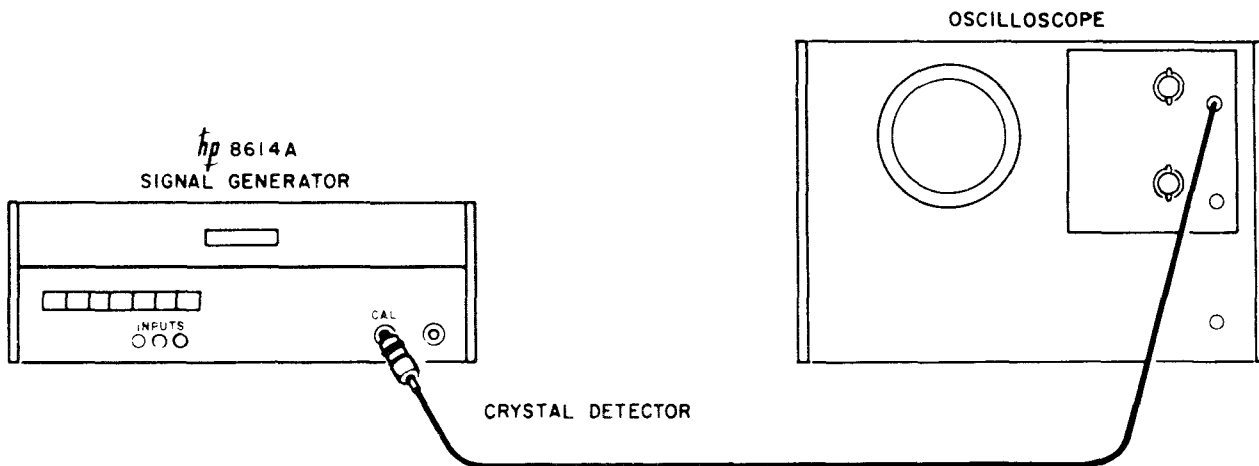

Figure 5-3. Internal Square-Wave Check

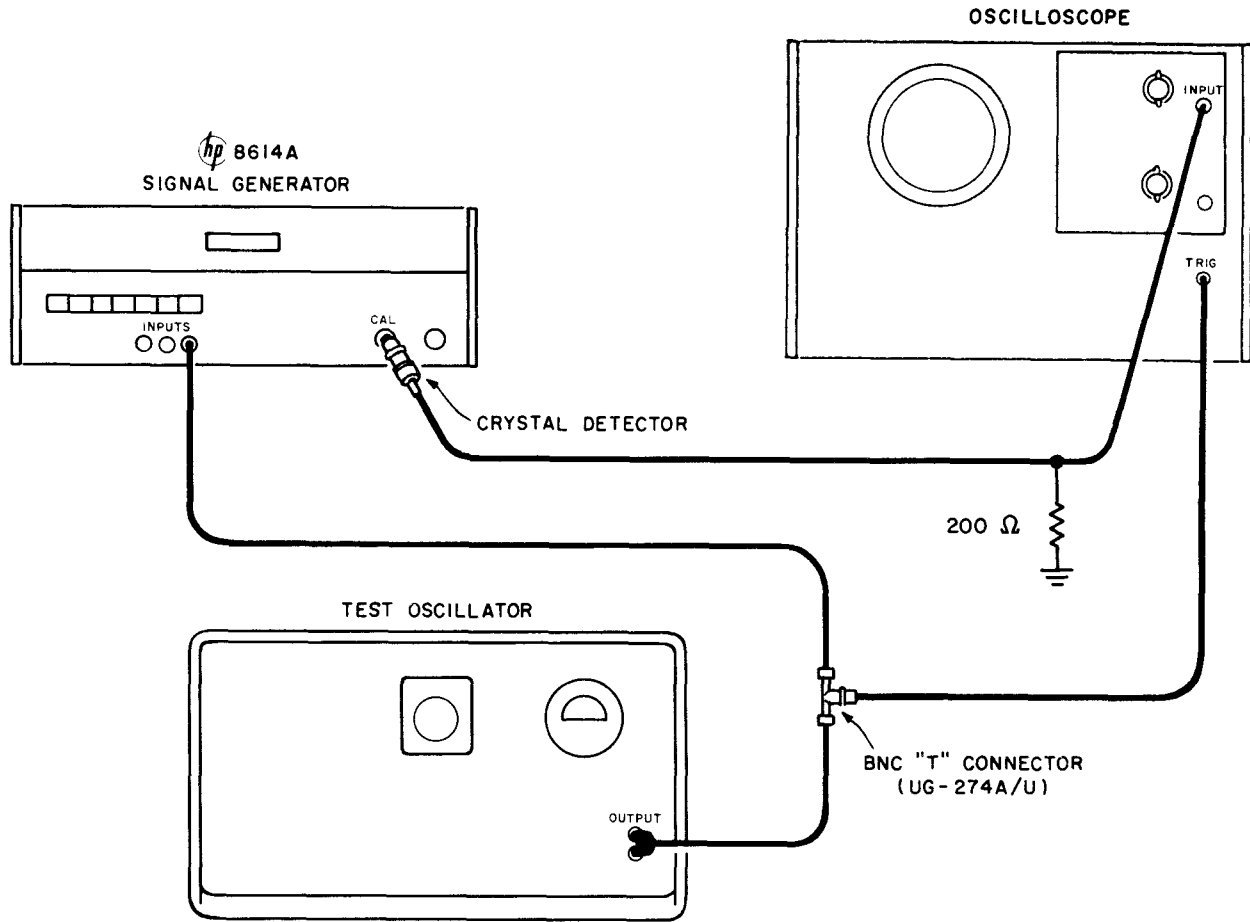

Figure 5-4. External AM Check

- c. Apply 5 to 6 volt peak sine wave to front panel BNC input.
- d. Using ALC CAL OUTPUT, vary dc level of detected sinusoid so there is no peak clipping (vary input amplitude if necessary).
- e. Adjust vertical sensitivity of oscilloscope to give 6-cm display of 1-kHz signal and then increase signal frequency to 1 MHz. The display should be greater than 3 cm.
- f. If AM operation is unsatisfactory, refer to paragraph 4-24.

5-17. MEASUREMENT OF RESIDUAL FM.

- a. Connect instruments as shown in Figure 5-5, without the test oscillator in the setup.
- b. Set up Model 8614A as follows:
 LINE depressed
 RF depressed
 FREQUENCY 1.8 GHz
- c. Adjust frequency meter output for 10 kHz/V. Line sync oscilloscope.

- d. Adjust transfer oscillator for 90 MHz and a harmonic of 20.
- e. Adjust frequency for 10 kHz difference frequency reading on frequency meter.
- f. Residual FM (line related components) reading ("peak to trough") on oscilloscope is less than 180 mV peak (180 mV = 1800 Hz).

5-18. MEASUREMENT OF INCIDENTAL FM.

- a. Set up Model 8616A as follows:
 INTERNAL SQ WAVE depressed
 ATTENUATION -10 dB
- b. Incidental FM is negligible.
- c. Connect instruments as shown in Figure 5-5, with the test oscillator in the setup.
- d. Set up Model 8616A as follows:
 EXTERNAL FM depressed
- e. Adjust test oscillator for a 10 kHz, 5 to 6 volt peak modulating signal.
- f. Incidental FM is negligible.

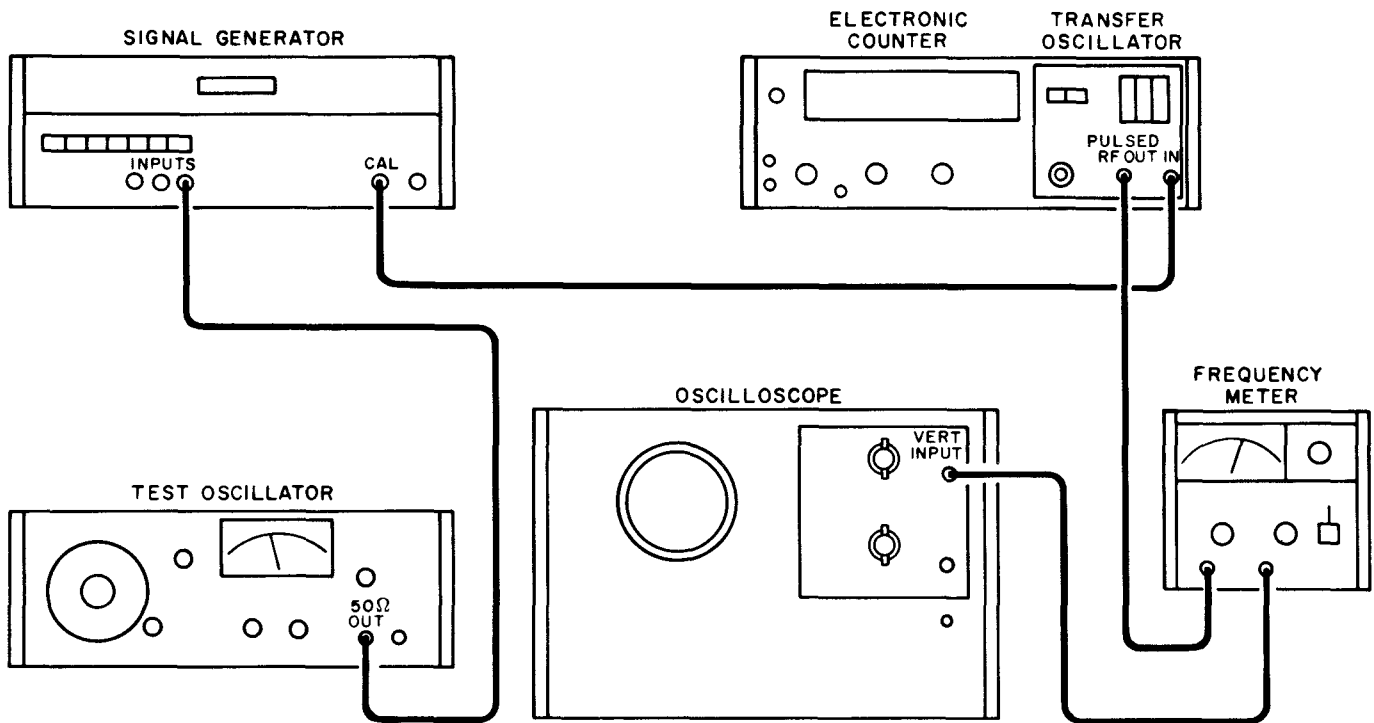

Figure 5-5. Residual and Incidental FM Check

5-19. TROUBLESHOOTING.

5-20. LOCATING TROUBLE

5-21. Always start locating trouble with a thorough visual inspection for burned-out or loose components, loose connections, or any condition which suggests a source of trouble. Check tubes for open filaments by touching tubes and replace all that are cold (except V105 and V202 which are cold cathode tubes). Replacing a cold tube, in some cases, will restore the generator to normal operation. Check the fuse to see that it is not open.

5-22. If trouble cannot be isolated to a bad component by visual inspection or a cold tube, the trouble should

then be isolated to a circuit section. Isolation to a circuit section can best be accomplished by reference to the block diagram (Figure 5-20), the troubleshooting charts (Tables 5-2 and 5-3), and isolation of all trouble symptoms using the performance check procedure (paragraph 5-8).

5-23. When testing the signal generator, it is recommended that line voltage be applied through a variable transformer and that the transformer be adjusted to deliver line voltage at the low end of the rated range (103 Vac for 115-volt operation and 207 Vac for 230-volt operation). An instrument in good condition should operate satisfactorily from any voltage within rated range, but where there is marginal operation (from weak tubes, etc), weaknesses become easier to trace at low line voltages.

Table 5-2. Power Supply Troubleshooting

Symptom	Conclusion	Remedy
<u>-350 VOLT SUPPLY</u>		
Connect voltmeter common to test point 1 and voltage lead to test point 2 (see Figure 5-7).		
-350 \pm 2 Vdc; 4 mV ac	Supply OK	
Small deviation	Out of adjustment	Adjust R212 (see Figure 5-6)
Large or erratic deviation	-350 V or -320 V supply bad	Remove V101 and V102 and connect a -320 V dc power supply between test point 1 and chassis ground. Recheck supply. If deviation still exists check C201, C202, CR201, or CR202 voltages at test point 14 (see Figure 5-19). If OK, check V201, V202, V203, V204.
	Note: See Figure 5-19 for component location	
<u>-320 VOLT SUPPLY</u>		
Connect voltmeter common to chassis ground and voltage lead to test point 1 (see Figure 5-7).		
+320 \pm 5 Vdc; 7 mV ac	Supply OK	
Small deviation	-350 V supply out of adjustment	Check and adjust -350 V supply
	-320 V or -350 V supply bad	Remove V201 and connect a -350 V dc power supply between test points 1 and 2. Recheck supply. If deviation still exists check C101, C102, CR101, or CR102 voltages at test point 13 (see Figure 5-19). If OK check V101, V102, V103, V104.
	Note: See Figure 5-19 for component location	
<u>-212 VOLT SUPPLY</u>		
Connect voltmeter common to chassis ground and voltage lead to test point 5 (see Figure 5-7).		
-212 \pm 5 Vdc	Supply OK	
Voltage unstable	Defective V105	Check V105
	Defective -320 V regulation	Check -320 V supply
<u>FILAMENT SUPPLY</u>		
Connect voltmeter between test points 3 and 4 (see Figure 5-22).		
-6.15 \pm 0.1 Vdc; 25 mV ac	Supply OK	
Small deviation	Out of adjustment	Adjust R5 (see Figure 5-6)
Large or erratic deviation	-320 V reference or filament regulation defective	Check -320 V supply Check Q1, Q2, CR1, or CR4 (see paragraph 5-28)
<u>+20 VOLT SUPPLY</u>		
Connect voltmeter common to chassis ground and voltage lead to test point 6 (see Figure 5-21).		
+20 \pm 0.1V; 4 mV ac	Supply OK	
Small deviation	Out of adjustment	Adjust R53 (see Figure 5-21)
Large or erratic deviation	-212 V reference or 20-V regulation	Check -212V supply Check Q50, Q51, Q52, Q53 (see paragraph 5-28)

Table 5-3. General Trouble Location

Symptom (outputs)	Trouble Location	Check
No RF	High-voltage power supply Filament supply RF probes Broken ground connection PIN diodes Klystron	Measure supply voltages (see Table 5-2) Measure supply voltages (see Table 5-2) Measure resistance of RF probes (see paragraph 5-62) Check chassis ground connections on both circuit boards Check RF PIN diodes (see paragraph 5-69) V1
No Sq Wave or Pulse	Modulation circuit	V401A/B
No ALC	Regulated +20 V supply ALC circuit ALC probe PIN diodes	Measure supply voltages (see Table 5-2) V501-502, Q501-503, Q601-606 Measure resistance (see paragraph 5-62) ALC PIN diodes and CR701 (see paragraph 5-62 and 5-69)

5-24. POWER SUPPLY TROUBLE.

5-25. Correct operation of the power supply is vital to proper operation of the signal generator. Noise or variation in the regulated voltages causes other circuits to operate in a random or erratic manner. It is advisable to make a voltage check of the power supply whenever the instrument is suspected of marginal operation. This eliminates factors such as low voltages

or poor regulation which cause unsatisfactory performance in other sections of the instrument.

5-26. The power supply consists of two interdependent series-regulated high voltage supplies furnishing -320 and -670 volts as measured from chassis ground and two series regulated low voltage supplies furnishing -6.15 and +20 volts.

a. The -320 volt supply furnishes voltage to the klystron cathode and modulation circuit. It also furnishes a regulated -212 volts for the modulation, ALC, and +20 volt supply circuits. This -212 volts is taken from a voltage regulator tube, V105, included between the -320 volt supply and chassis ground.

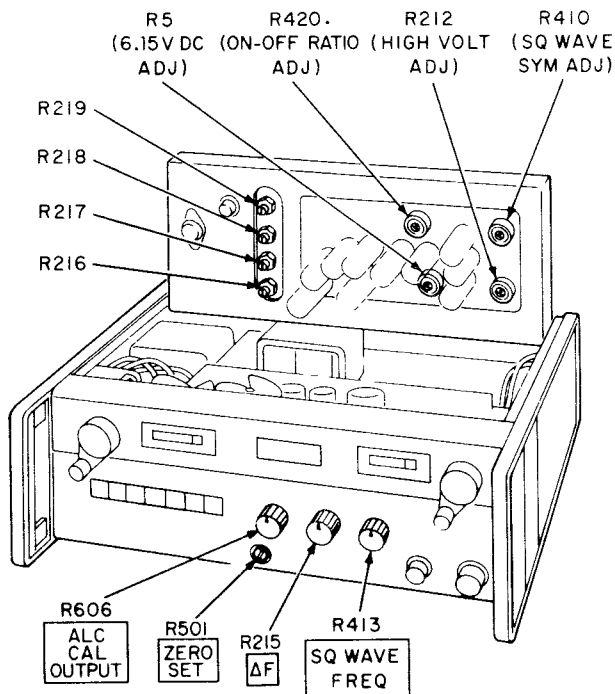

Figure 5-6. Electrical Adjustment Location

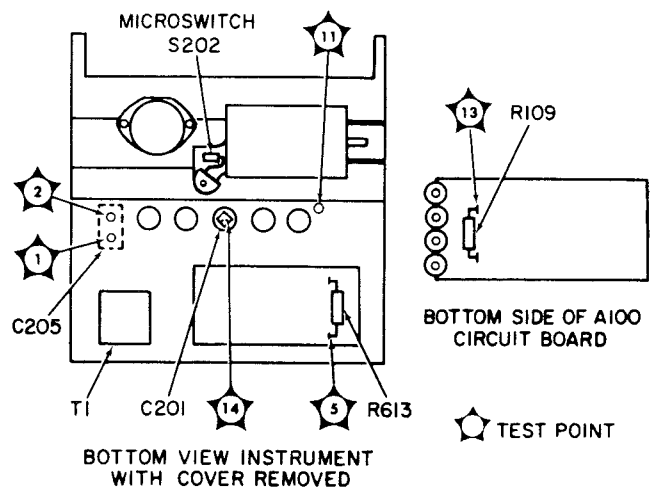

Figure 5-7. High-Voltage Test Point Location

A. TRANSISTOR BIASING			
DEVICE	SYMBOL	CUTOFF	CONDUCTING
VACUUM TUBE			
N P N TRANSISTOR			
P N P TRANSISTOR			

B. AMPLIFIER CHARACTERISTICS			
CHARACTERISTIC	COMMON BASE	COMMON EMITTER	COMMON COLLECTOR
INPUT Z	30-50 Ω	500-1500 Ω	20-500K Ω
OUTPUT Z	300-500K Ω	30-50K Ω	50-1000 Ω
VOLTAGE GAIN	500-1500	300-1000	<1
CURRENT GAIN	<1	25-50	25-50
POWER GAIN	20-30 dB	25-40 dB	10-20 dB

Figure 5-8. Transistor Biasing and Operating Characteristics

b. The -670 volt supply consists of a -350 volt regulated supply stacked with the -320 volt supply. The -670 volt supply furnishes the klystron and modulation circuit.

c. The two low voltage supplies provide filament voltages (-6.15 volt supply) and operating voltages (+20 volt supply) to the ALC circuit. Both low voltage supplies are completely dependent upon proper operation of the high voltage supplies for their individual operation.

d. The two high voltage supplies are stacked and each supply provides reference voltages to the other. To troubleshoot either supply, always remove series regulator from one supply (V201 for the -350 volt supply; V101 and V102 for the -320 volt supply) and replace with an external dc supply in order to check the other supply (see Table 5-2).

e. If trouble is isolated to either the -6.15 volt or +20 volt regulated supply refer to paragraph 5-28 for suggested troubleshooting techniques for transistor circuits (both "in-circuit" and "out-of-circuit" techniques).

5-27. To measure and adjust power supply voltages, remove top and bottom covers from instrument. Remove two screws that secure hinged power-supply board and place instrument on its side.

a. Set rear panel 115/230 switch as appropriate and check that proper fuse is installed in instrument.

b. Depress LINE button. Connect dc voltmeter and ac voltmeter in parallel and measure power supply voltages as instructed in Table 5-2.

WARNING

When using a metal case VTVM with common lead connected to chassis ground (the metal case), the metal case will be at common lead potential.

5-28. TRANSISTOR TROUBLESHOOTING.

5-29. The following procedures and data are given to aid in determining whether a transistor is operational. Tests are given for both in-circuit and out-of-circuit transistors.

5-30. IN-CIRCUIT TESTING.

5-31. The common causes of transistor failures are internal short- and open-circuits. In transistor circuit testing the most important consideration is the transistor base-emitter junction. Like the control grid of a vacuum tube, this is the operational control point in the transistor. This junction is essentially a solid-state diode. For the transistor to conduct, the diode must conduct; that is, the diode must be forward biased. As with simple diodes, the forward-bias polarity is determined by the materials forming the junction. Use the transistor symbol on the schematic diagram to determine the bias polarity required to forward-bias the base-emitter junction. The A part of Figure 5-8 shows transistor symbols with terminals labelled. Notice that the emitter arrow points toward

the type N material. The other two columns of the illustration compare the biasing required to cause conduction and cut-off in transistors and vacuum tubes. If the transistor base-emitter diode (junction) is forward-biased the transistor conducts. If the diode is heavily forward-biased, the transistor saturates. However, if the base-emitter diode is reverse-biased the transistor is cut off (open). The voltage drop across a forward-biased emitter-base diode varies with transistor collector current. For example, a germanium transistor has a typical forward-bias, base-emitter voltage of 0.2-0.3 volts when collector current is 1-10 mA, and 0.4-0.5 volts when collector current is 10-100 mA. In contrast, forward-bias voltage for silicon transistors is about twice that for germanium types: about 0.5-0.6 volts when collector current is low, and about 0.8-0.9 volts when collector current is high.

5-32. Figure 5-8, part B, shows simplified versions of the three basic transistor circuits and gives the operating characteristics of each. When examining a transistor stage, first determine if the emitter-base diode is biased for conduction (forward-biased) by measuring the voltage difference between emitter and base. When using an electronic voltmeter, do not measure directly between emitter and base: there may be sufficient loop current between the voltmeter leads to damage the transistor. Instead, measure each voltage separately with respect to a voltage common point (e.g., chassis). If the emitter-base diode is forward-biased, check for amplifier action by short-circuiting base to emitter while observing collector voltage. The short circuit eliminates base-emitter bias and should cause the transistor to stop conducting (cut off). Collector voltage should then shift to near the supply voltage. Any difference is due to leakage current through the transistor and, in general, the smaller this current, the better the transistor. If collector voltage does not change the transistor has either an emitter-collector short circuit or emitter-base open circuit.

5-33. OUT-OF-CIRCUIT TESTING.

5-34. The two common causes of transistor failure are internal short- and open-circuits. Remove the transistor from the circuit and use an ohmmeter to measure internal resistance. See Table 5-4 for measurement data.

CAUTION

Most ohmmeters can supply enough current or voltage to damage a transistor. Before using an ohmmeter to measure transistor forward or reverse resistance, check its open-circuit voltage and short-circuit current output **ON THE RANGE TO BE USED**. Open-circuit voltage must not exceed 1.5 volts and short-circuit current must be less than 3 mA. See Table 5-5 for safe resistance ranges for some common ohmmeters.

5-35. ETCHED CIRCUITS.

5-36. The etched circuit boards in the Signal Generator are of the plated-through type consisting of metallic conductors bonded to both sides of insulating material. The metallic conductors are extended

Table 5-4. Out-of-Circuit Transistor Resistance Measurements

Transistor Type		Connect Ohmmeter		Measure Resistance (ohms)
		Pos. lead to	Neg. lead to	
PNP Germanium	Small Signal	emitter	base*	200-250
		emitter	collector	10K-100K
	Power	emitter	base*	30-50
		emitter	collector	several hundred
NPN Silicon	Small Signal	base	emitter	1K-3K
		collector	emitter	very high (might read open)
	Power	base	emitter	200-1000
		collector	emitter	high, often greater than 1M

* To test for transistor action, add collector-base short. Measured resistance should decrease.

Table 5-5. Ohmmeter Ranges for Transistor Resistance Measurements

Ohmmeter	Safe Range(s)	Open Ckt Voltage	Open Ckt Current	Lead	
				Color	Polarity
HP 412A	R x 1K	1.0V	1 mA	Red Black	+ -
	R x 10K	1.0V	100 μ A		
	R x 100K	1.0V	10 μ A		
	R x 1M	1.0V	1 μ A		
	R x 10M	1.0V	0.1 μ A		
HP 410C	R x 1K	1.3V	0.57mA	Red Black	+ -
	R x 10K	1.3V	57 μ A		
	R x 100K	1.3V	5.7 μ A		
	R x 1M	1.3V	0.5 μ A		
	R x 10M	1.3V	0.05 μ A		
HP 410B	R x 100	1.1V	1.1mA	Black Red	+ -
	R x 1K	1.1V	110 μ A		
	R x 10K	1.1V	11 μ A		
	R x 100K	1.1V	1.1 μ A		
	R x 1M	1.1V	0.11 μ A		
Simpson 260	R x 100	1.5V	1 mA	Red Black	+ -
Simpson 269	R x 1K	1.5V	0.82mA	Black Red	+ -
Triplet 630	R x 100	1.5V	32 mA	Varies with Serial Number	
	R x 1K	1.5V	3.25mA		
Triplet 310	R x 10	1.5V	750 μ A		
	R x 100	1.5V	75 μ A		

through the component mounting holes by a plating process. Soldering can be done from either side of the board with equally good results. Table 5-6 lists required tools and materials. Following are recommendations and precautions pertinent to etched circuit repair work.

a. Avoid unnecessary component substitution; it can result in damage to the circuit board and/or adjacent components.

b. Do not use a high-power soldering iron on etched circuit boards. Excessive heat may lift a conductor or damage the board.

c. Use a suction device (Table 5-6) or wooden toothpick to remove solder from component mounting holes. DO NOT USE A SHARP METAL OBJECT SUCH AS AN AWL OR TWIST DRILL FOR THIS PURPOSE. SHARP OBJECTS MAY DAMAGE THE PLATED-THROUGH CONDUCTOR.

d. After soldering, remove excess flux from the soldered areas and apply a protective coating to prevent contamination and corrosion. See Table 5-6 for recommendations.

e. When removing a multiple-connection component held tightly in a socket, such as a vacuum tube, loosen it gradually using gentle side-to-side or rotary motion to avoid damage to the plated-through conductor.

5-37. COMPONENT REPLACEMENT.

a. Remove defective component from circuit board.

b. Remove solder from mounting holes using a suction desoldering aid (Table 5-6) or wooden toothpick.

c. Shape leads of replacement component to match mounting hole spacing.

d. Insert component leads into mounting holes and position component as original was positioned. DO NOT FORCE LEADS OF REPLACEMENT COMPONENT INTO MOUNTING HOLES. Sharp lead ends may damage plated-through conductor.

Note

Axial lead components, such as resistors and tubular capacitors, can be replaced without unsoldering. Clip leads near body of defective component, remove component and straighten leads left in board. Wrap leads of replacement component one turn around original leads. Solder wrapped connection, and clip off excess lead.

5-38. TUBE SOCKET REPLACEMENT. There are three ways to remove a tube socket from the etched circuit board:

- (1) Cut terminals attaching socket to circuit board, remove socket, and unsolder remaining terminal pieces individually.
- (2) Using long nose pliers, break insulating material of socket away from its metal connectors, then unsolder connectors from board individually.

Table 5-6. Etched Circuit Soldering Equipment

Item	Use	Specifications	Item Recommended
Soldering Tool	Soldering Unsoldering	Wattage rating: 37.5 Tip Temp: 750 - 800°F Tip Size: 1/8" OD	Ungar #776 Handle with Ungar #1237 Heating Unit
Soldering Tip, general purpose	Soldering Unsoldering	Shape: chisel Size: 1/8"	Ungar #PL113
De-soldering aid	Unsoldering multi- connection components (e.g., tube sockets)	Suction device to remove molten solder from connection	Soldapullt by the Edsyn Company, Arleta, California
Resin (flux) solvent	Remove excess flux from soldered area before application of protective coating	Must not dissolve etched circuit base board material or conductor bonding agent	Freon Acetone Lacquer thinner Isopropyl Alcohol (100% dry)
Solder	Component replacement Circuit board repair Wiring	Resin (flux) core, high tin content (60/40 tin/lead), 18-gauge (SWG) preferred	
Protective coating	Contamination, corrosion protection after soldering	Good electrical insulation corrosion-prevention properties	Krylon

(3) Use a special soldering iron tip designed to heat all socket connections simultaneously and remove socket as a unit; or use a suction device (Table 5-6) to desolder all connections and remove socket.

5-39. ETCHED CONDUCTOR REPAIR. A broken or burned section of conductor can be repaired by bridging the damaged section with a length of tinned copper wire. Allow adequate overlap and remove any varnish from etched conductor before soldering wire into place.

5-40. TRANSISTOR REPLACEMENT.

a. Do not apply excessive heat. See Table 5-6 for soldering tool specifications.

b. Use a heat sink such as pliers or hemostat between transistor body and hot soldering iron.

c. When installing a replacement transistor, ensure sufficient lead length to dissipate heat of soldering by maintaining about the same length of exposed lead as used for original transistor.

5-41. KLYSTRON REPLACEMENT.

5-42. TUBE REMOVAL.

WARNING

BEFORE ATTEMPTING KLYSTRON REMOVAL OR REPLACEMENT, BE CERTAIN THAT LINE POWER IS COMPLETELY REMOVED FROM INSTRUMENT.

a. Remove panel cover on left (with respect to front panel) side of instrument.

b. Set klystron frequency drive at top end (2400-MHz frequency dial setting).

c. Using truarc pliers which are available in a repair kit, HP Stock No. 08614-800, remove the outer truarc ring from the outer cover of the klystron cavity (see Figure 5-9).

d. Remove outer cover. Pull tube socket from klystron with a straight pull.

e. Remove inner truarc ring holding klystron clamp housing in klystron cavity. Grasp klystron tube and remove from cavity.

f. Unscrew clamp nut, lift out clamp spacer, and remove klystron (see Figure 5-9).

g. Remove waffle washer from cavity.

Note

Refer to paragraph 1-14 for klystron warranty claim instructions.

5-43. TUBE REPLACEMENT.

a. Reassemble new klystron, housing, spacer, and nut.

b. Set klystron frequency drive at top end (high frequency dial setting) for klystron centering.

c. Place waffle washer in klystron cavity.

d. Insert klystron into klystron cavity.

CAUTION

Klystron should be inserted straight into cavity. Insertion of klystron should require no unnecessary force; the klystron should fit snugly but easily, into cavity.

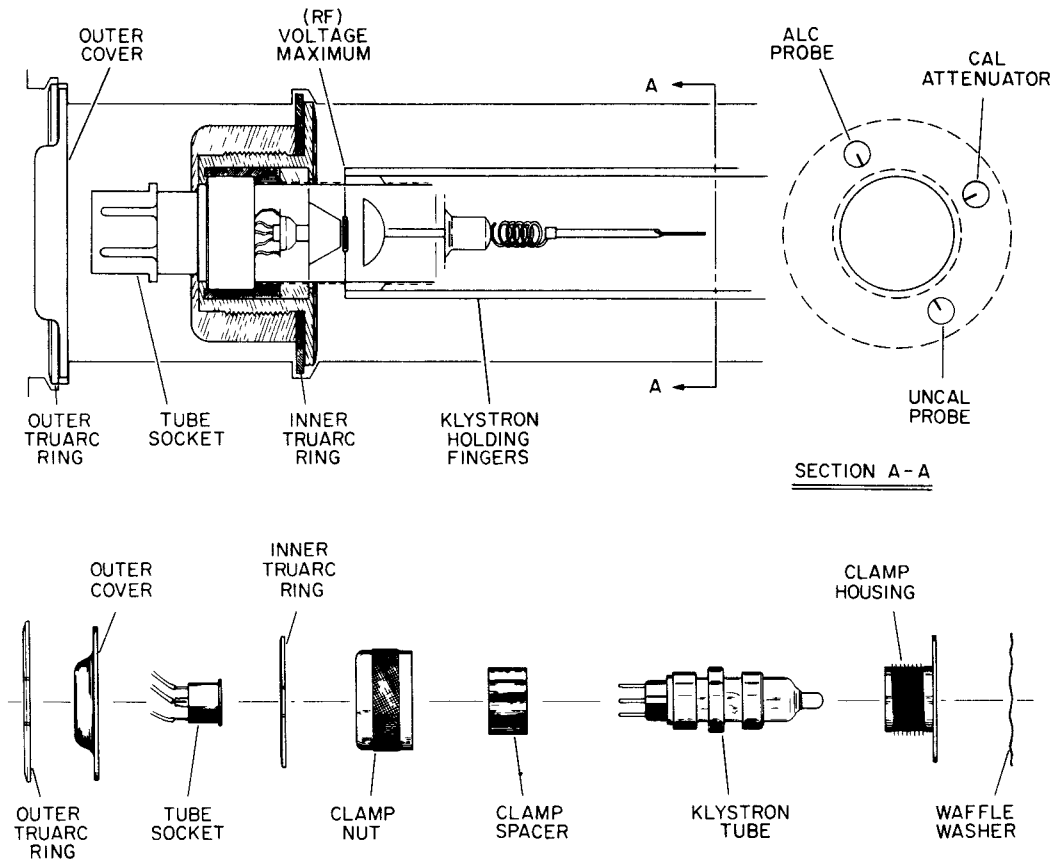

Figure 5-9. Klystron Cavity Assembly, Cutaway View

- e. Replace inner truarc ring on clamp housing (if the klystron is properly in place the ring will fit properly). Allow tube to be centered by center conductor.
- f. Install tube socket and outer cover.
- g. Place edge of truarc ring on outer cover and rotate until ring lies flat on cover and is easily accessible with truarc pliers.
- h. Refer to Adjustment Procedure (paragraph 5-56) and make necessary adjustments.

5-44. RF PROBE REPLACEMENT.

5-45. PROBE REMOVAL.

WARNING

BEFORE ATTEMPTING PROBE ASSEMBLY REMOVAL OR REPLACEMENT, BE CERTAIN THAT LINE POWER IS COMPLETELY REMOVED FROM INSTRUMENT.

- a. Remove top cover from instrument.
- b. Set FREQUENCY (MHz) drive to the highest frequency setting (2400 MHz).
- c. Remove attenuator access cover from klystron cavity casting (see Fig. 5-13)

- d. Remove right side frame assembly.
- e. Remove cable guide from klystron cavity casting and disconnect cable assembly connectors from instrument.
- f. Remove the cable assembly connector from the defective RF probe cable. Be careful not to lose any connector parts as they will be required for reassembly.
- g. Remove the probe guide from the cable guide.
- h. Remove the retaining screw holding the defective probe in the tuning carriage and remove the probe from the casting.
- i. The defective probe assembly should be returned to your local Hewlett-Packard sales and service office for repair or replacement.

5-46. PROBE REPLACEMENT.

CAUTION

The probe is fragile and should be handled with care. The probe should be placed in a protective shield when handling or shipping.

- a. To install a new probe assembly, carefully insert the new probe into the klystron cavity casting and replace the probe retaining screw.

CAUTION

Care must be taken not to damage the resistive element on the probe end or the spring wipers that make contact with the probe guide tube.

- b. Insert the probe assembly cable through the cable guide. Install the cable guide.
- c. Trim the insulation from the end of the probe assembly cable (for RF UNCAL probe, 5/16 inch; for RF CAL and ALC probes, 1/4 inch).
- d. Place cable assembly connector parts on cable, with the exception of the clamping body, and fold the braid back upon the connector assembly (see Figure 5-10 P/O Errata).
- e. Place the clamping body on the cable and screw the clamp nut and clamping body together.
- f. Trim the dielectric flush with the end of the clamping body so that the center conductor is bare.
- g. Trim the center conductor protruding from the clamping body, then place the insulator washer on the center conductor.

NOTE

After tinning center conductor the diameter may be too large, making it necessary to file the center conductor to the proper diameter.

- h. Before connecting connector assembly into the instrument, connect an ohmmeter between the probe center conductor and ground and measure the resistance across the range of the attenuator. The resistance should be approximately 50 ohms \pm 5 ohms. If the probe is open or shorted at any point, the probe is defective and should be replaced.
- i. Replace the connector assembly as it was before disassembly. Connect the probe connector to the instrument, making certain the center conductor makes good contact.
- j. The probe installation is complete. Reassemble the instrument except for the front, right side panel, which is removed when performing the output power calibration adjustments.

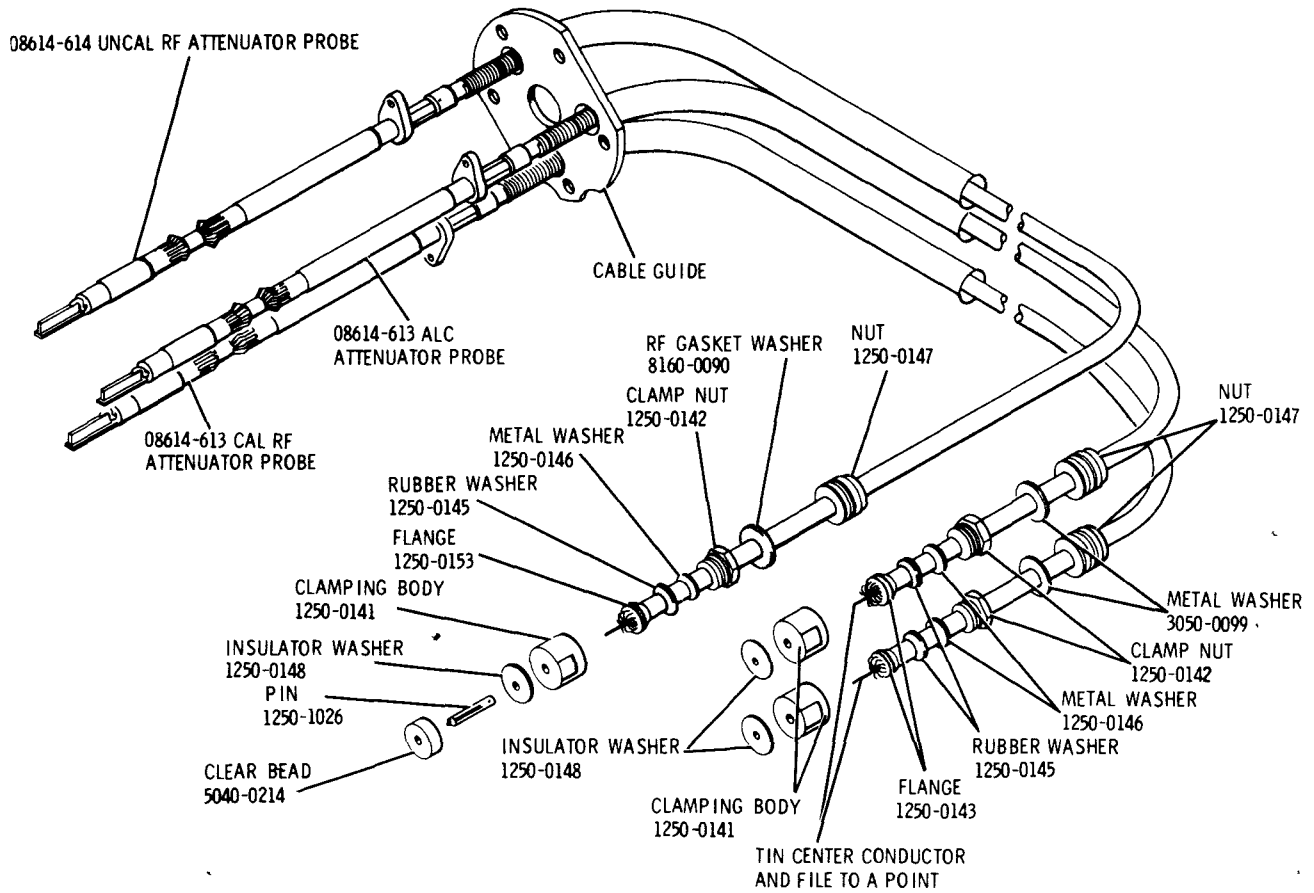

8614A

Figure 5-10. RF Probe Assembly (P/O Errata)

CAUTION

Care should be taken not to damage the resistive element (probe end), or the spring wipers that make contact with probe guide tube.

b. The probe assembly cable must be inserted through the cable guide (see Figure 5-10).

c. Trim insulation from end of probe assembly cable (for RF UNCAL OUTPUT probe, 5/16 inch; for RF and ALC ATTENUATOR probes, 1/4 inch).

d. Place cable assembly connector parts on cable with the exception of clamping body, and fold braid back upon connector assembly.

e. Place clamping body on cable and screw clamp nut and clamping body together.

f. Trim dielectric flush with end of clamping body so that center conductor is bare.

g. Tin center conductor protruding from clamping body, then place insulator washer on center conductor. Note: After tinning center conductor diameter may be too large making it necessary to file center conductor to proper diameter.

h. Before connecting connector assembly into instrument, connect an ohmmeter between probe center conductor and ground and measure resistance across range of attenuator. Specification: resistance should be approximately 55 ohms.

i. Replace connector assembly as it was before disassembly. Refer to Power Adjustment (paragraph 5-61) and make necessary check and adjustment.

5-47. PIN MODULATOR REPLACEMENT.**5-48. MODULATOR REMOVAL:**

5-49. The PIN modulator CANNOT be repaired in the field. If the PIN modulator is found to be faulty, it should be returned for repair. Remove the four screws holding the PIN modulator only. Removal of screws holding the PIN diodes in place can cause contamination of the PIN diodes, high SWR, etc.

- a. Remove power line from instrument.
- b. Remove top and bottom covers.
- c. Place instrument on its side.

CAUTION

DO NOT HANDLE CRYSTAL DIODE, CR701, NEEDLESSLY. A static charge which builds up on a body, especially on a cold, dry day, must NEVER be allowed to discharge through element. When installing or removing touch casting first to insure no difference in potential between hand and casting.

- d. Disconnect ground lug and wire from low pass filter.

NOTE

CR701 should always be left on old pin line. Replacement pin lines should always have CR701 installed when received. Solder lead to center pin of filter and install ground lug back on pin line.

- e. Disconnect cable assembly connectors from the modulator (see Figure 5-10). Be careful not to lose any disassembled parts as they will be required for reassembly.

CAUTION

Do not disconnect RF output from modulator

- f. Disconnect RF OUTPUT cable at RF CAL OUTPUT connector at front panel.
- g. Disconnect ALC Bias Feed connections (1 and 2 on A500 board) from ALC circuit board.

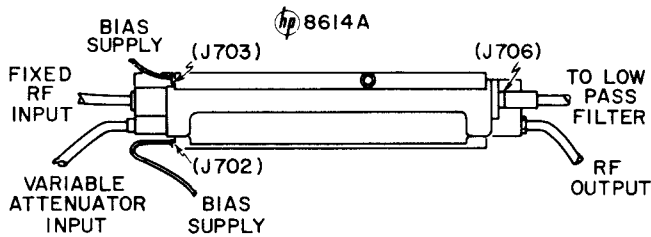

Figure 5-11. PIN Modulator (External View)

- h. Remove four screws holding PIN modulator to instrument chassis.
- i. Remove PIN modulator from instrument.
- j. Carefully pack PIN modulator in a container and return to your local Hewlett-Packard sales and service office for repair or replacement.

5-50. MODULATOR REPLACEMENT.

- a. Before installing PIN modulator, measure a resistance of PIN diodes with voltmeter, such as HP 410B.
- b. To measure PIN diode resistance, measure resistance between J703 and modulator ground and J702 and modulator ground. On the ohmmeter RX100 range with the common lead connected to ground, the resistance should measure approximately 1000 to 1500 ohms. On the ohmmeter RX1 Meg range with the ohms lead connected to ground, the resistance should measure approximately 100 megohms.
- c. Replace four screws that hold PIN modulator in place.
- d. Connect RF OUTPUT cable to front panel.
- e. Connect ALC Bias Feed connections to ALC circuit board (A500).
- f. Connect cable assembly connectors to PIN diode modulator. (See CAUTION, paragraph 5-49).

5-51. CAM CABLE REPLACEMENT.

5-52. TOOLS REQUIRED.

- a. Open-end wrench (3/8-inch).
- b. Hex-socket wrench and 3/8-inch socket or equivalent tool.
- c. Book of matches.
- d. Roll of masking tape (1/2-inch or 1-inch width).
- e. Rubber cement.

5-53. PROCEDURE.

5-54. If it is necessary to replace cam cable, order it by HP Stock No. 08614-299 and description of usage. For easier access to the cams, remove the screws holding the High Voltage circuit board and swing the board out of the way. Use Figures 5-12 and 5-13 as guides and proceed as follows:

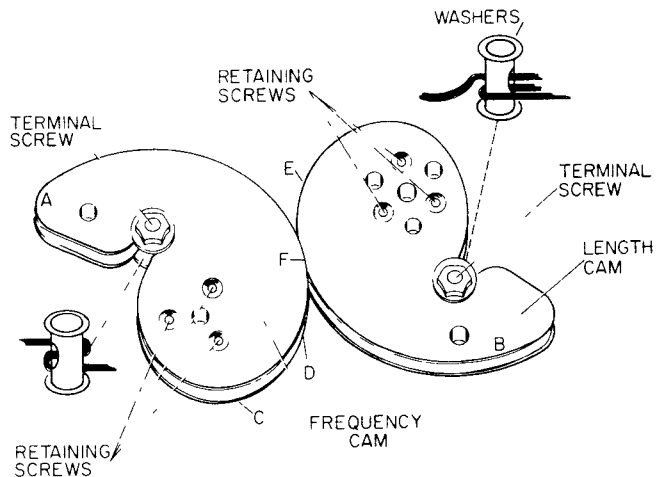

Figure 5-12. Cam Assembly

- a. Remove power cord from instrument.
 - b. Remove instrument top cover and attenuator access cover.
 - c. Turn FREQUENCY (MC) to approximately the middle of the frequency band.
 - d. Orient Length Cam to Frequency Cam as shown in Figure 5-12.
 - e. Using a lead pencil, mark position of each cam and end of threaded portion of center conductor support rod on klystron cavity casing.
 - f. Using hex socket wrench and a 3/8-inch open-end wrench, remove both terminal screws, the four washers, and the two nuts (10-32 x 0.375 hex nuts).
 - g. Remove both terminal screws from cable.
 - h. On replacement cable, place a mark halfway between each end. Using matches apply heat to an area approximately 1 2 to 3/4 inch on either side of mark to remove wire tension (heat to nearly white hotness).
 - i. Cut 10 or 11 strips of masking tape approximately one inch in length.
 - j. Remove three retaining screws from Frequency Cam and remove cam from instrument (Note: three retaining screws are 4-40 x 0.625 FH).
 - k. Slide cable through one terminal screw so that cable is oriented to terminal screw as shown in Figure 5-12 for the Frequency Cam, and install terminal screws on Frequency Cam.
- CAUTION:** Be careful not to catch cable between lockwasher and cam.
- m. Slide cable onto cam just past point A and tape to cam (half of cable length should pass over points A and B; the other half should pass over points C, D, and E).

Note

Each cam as shown in Figure 5-12 has two lips along which the cable should travel: one cable must travel along the upper lip of both cams and one cable must travel along the lower lip of both cams.

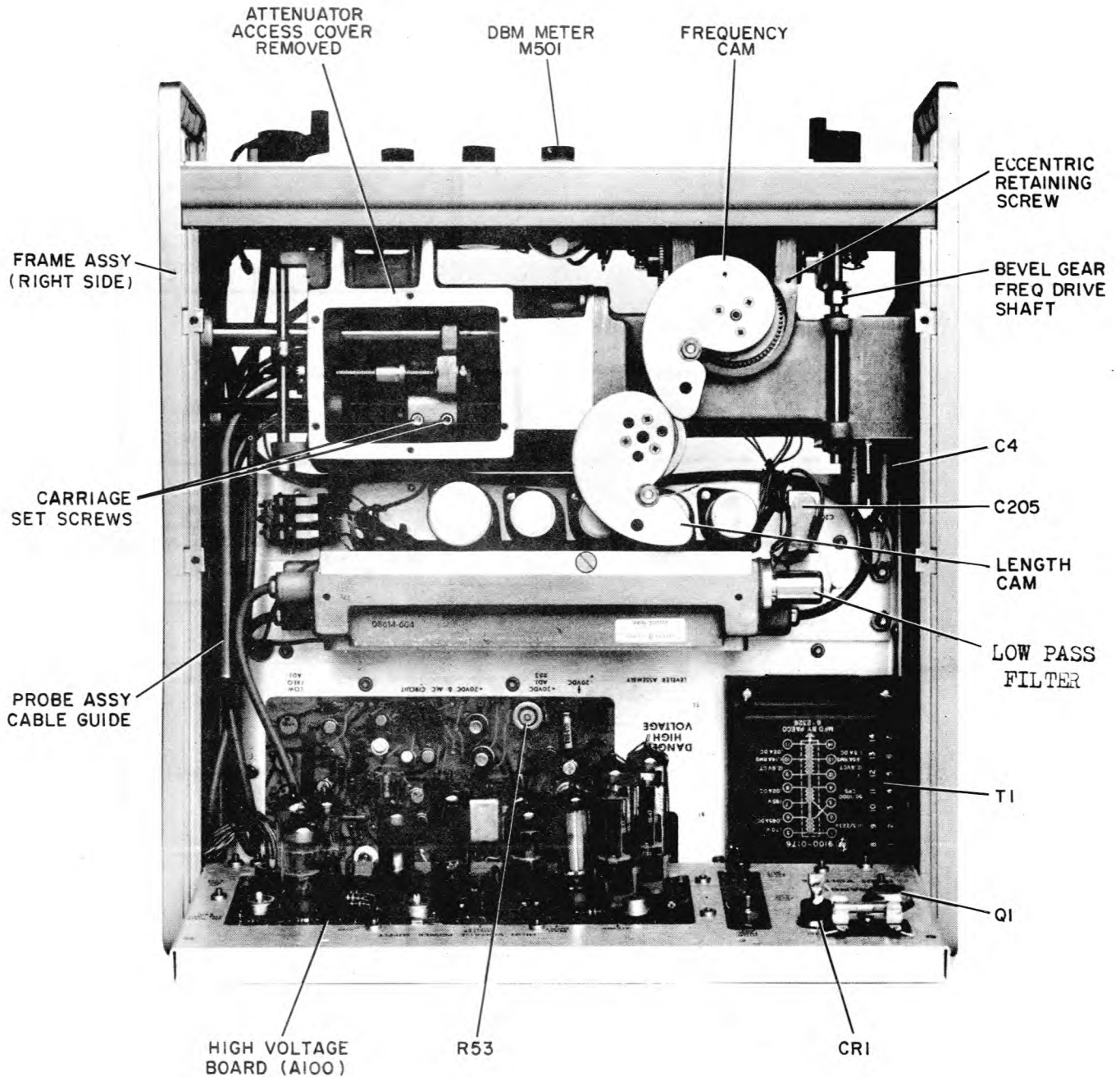

Figure 5-13. Instrument Top View, Cover Removed

n. Slide other half portion of cable onto cam just past point D and tape to cam.

p. Place Frequency Cam in original position in instrument and replace retaining screws.

q. Turn Length Cam so that cams are not touching at point F and place cable between cams: one cable along upper lip of cam and the other along lower lip of cam.

r. Turn Length Cam so it is apparently touching Frequency Cam at point F and place two pieces of masking tape across the two cams at point F.

s. With cams held together, slide cable which passes over points C and D past point E and cable which passes over point A past point B and tape each portion of cable to cam.

Note

It is important that each cable portion have as little slack between it and the cams as possible: a loose cable causes backlash.

t. Slide cable ends through second terminal screw so that cable is oriented to terminal screw as shown in Figure 5-12 for the Length Cam.

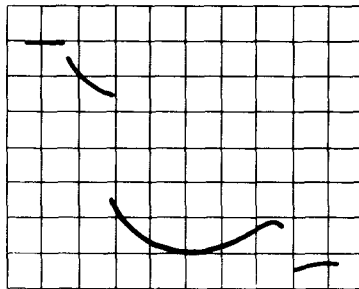
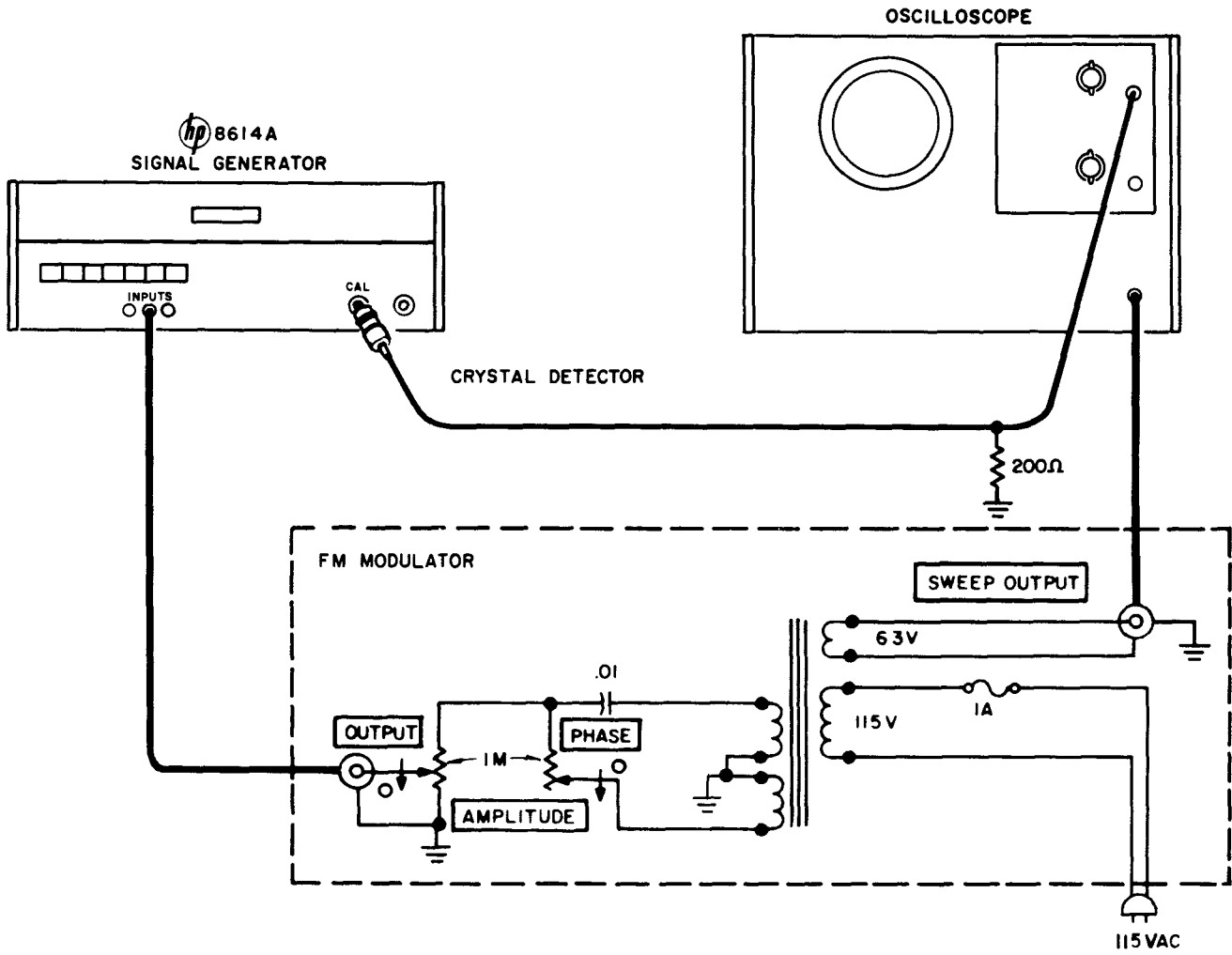

950 MHz
R216

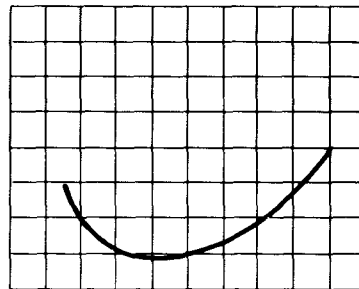

1600 MHz BELOW SWITCH
R217

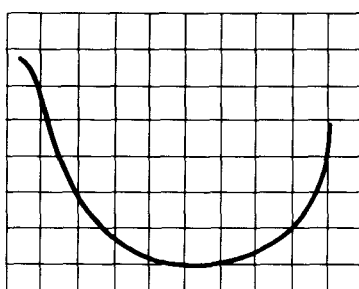

1600 MHz ABOVE SWITCH
R218

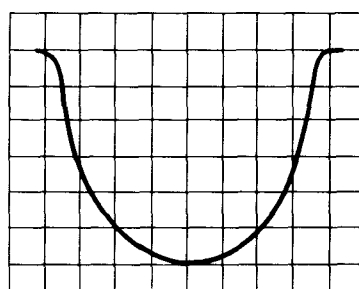

2400 MHz
R219

Figure 5-14. Repeller Mode Adjust Setup

u. Install second terminal screw on Length Cam and tighten both terminal screws to remove all slack in cable.

v. Remove masking tape from cams and apply rubber cement to ends of cable to ensure that cable will not unravel.

w. Turn FREQUENCY(MC) knob to match Frequency Cam to pencil mark made in step e; the other marks made should match appropriately.

x. Perform Frequency Range Spread Adjustment, paragraph 5-60.

5-55. ADJUSTMENTS.

5-56. ADJUSTMENT AFTER KLYSTRON REPLACEMENT.

5-57. Following replacement of a klystron, certain adjustments must be made before the instrument will operate properly. The general steps in the overall procedure are as follows:

- a. Establish initial repeller tracking voltages.
- b. Establish proper repeller mode operation.
- c. Adjust frequency range spread.
- d. Adjust power output.
- e. Check internal leveling operation.

5-58. INITIAL REPELLER-VOLTAGE ADJUST.

a. Remove top and bottom covers and remove two screws that secure circuit board.

b. Check all power supply voltages as indicated in Table 5-2.

c. Connect voltmeter between klystron repeller (test point 11 and chassis ground, see Figure 5-7). Make sure ΔF control on front panel is set at zero (center position), and set voltages as indicated in Table 5-7 (see Figure 5-6).

WARNING

Be careful not to ground test point 11 as power supply will be destroyed.

Table 5-7. Klystron Repeller Voltages

Frequency Dial	Adjust	Voltage (between klystron repeller and ground)
800	R216	-370 \pm 5V
Mid-frequency below switch above switch	R217	-600 \pm 5V
	R218	-425 \pm 5V
2400	R219	-580 \pm 5V
Note: R216 and R217 interact as do R218 and R219; therefore, repeat above measurements after any adjustments.		

5-59. REPELLER MODE ADJUST.

a. At a dial frequency of 950 MHz set attenuator dial for a calibrated output of about 0 dBm.

b. To observe repeller modes of the klystron, a FM Modulator, with adjustable phase and amplitude controls, is necessary. Such a device is shown in Figure 5-14; it consists of a small power transformer connected with the primary and secondary windings interchanged; two one-megohm potentiometers; a 0.01 μ f capacitor; two BNC connectors; a fuseholder, and a power cord. Connected as shown, this modulator provides a power line frequency modulation voltage continuously variable in amplitude from 300 volts peak-to-peak, with phase variable over a range of approximately 95 degrees, plus a 6.3-volt ac output for oscilloscope sweep control (see Table 5-1).

c. Apply external FM (60 cycles) and view mode patterns on oscilloscope. Adjust PHASE control of FM modulator and appropriate tracking pot for mode patterns shown.

Note

DC repeller voltages at 950 MHz and 1600 MHz (above switch) are relatively small and will not appear correctly if FM signal is excessive.

- (1) Adjustments should allow about 2-MHz variation with ΔF control.
- (2) The tracking pots interact making it necessary to repeat the adjustments a time or two in order to insure proper tracking.

d. Connect a clip-on milliammeter to wire on center feed-through capacitor, C4 (wht /orn /vio wire, see Figure 5-13). Current must not exceed 30 mA unless klystron is defective.

5-60. FREQUENCY RANGE SPREAD ADJUST.

a. Using a calibrated frequency meter, measure actual frequency at dial settings of 1000 and 2400 MHz. To eliminate backlash error, always approach frequency dial settings from the same direction.

b. The difference in the frequency measurements of step a should be 1400 MHz. If frequency difference is other than specified, correction must be made (see step c).

c. Refer to graph, Figure 5-15. The horizontal axis represents the measured frequency change from step b, the vertical axis indicates the dial corrective setting. For example, if the difference between dial settings (step b) is 1354 MHz, the corrective setting for the dial as found on the graph is 990 MHz. To make correction, set frequency dial to 1000 MHz, loosen the two setscrews that clamp dial plunger to rack, hold dial plunger stationary, and set dial to 990 MHz. Tighten two setscrews (see Figure 5-16).

d. If any adjustment was necessary, repeat steps a, b, and c. Repeat this procedure until measured frequency difference corresponds to a change of 1400 MHz \pm 3 MHz.

e. Set actual frequency to 1000 MHz. Loosen spur gear on worm shaft and rotate gear until frequency dial reads 1000 MHz (see Figure 5-13).

f. Check FREQUENCY(MC) dial settings at both upper and lower ends of dial travel. The respective dial end points should be less than 800 MHz and greater

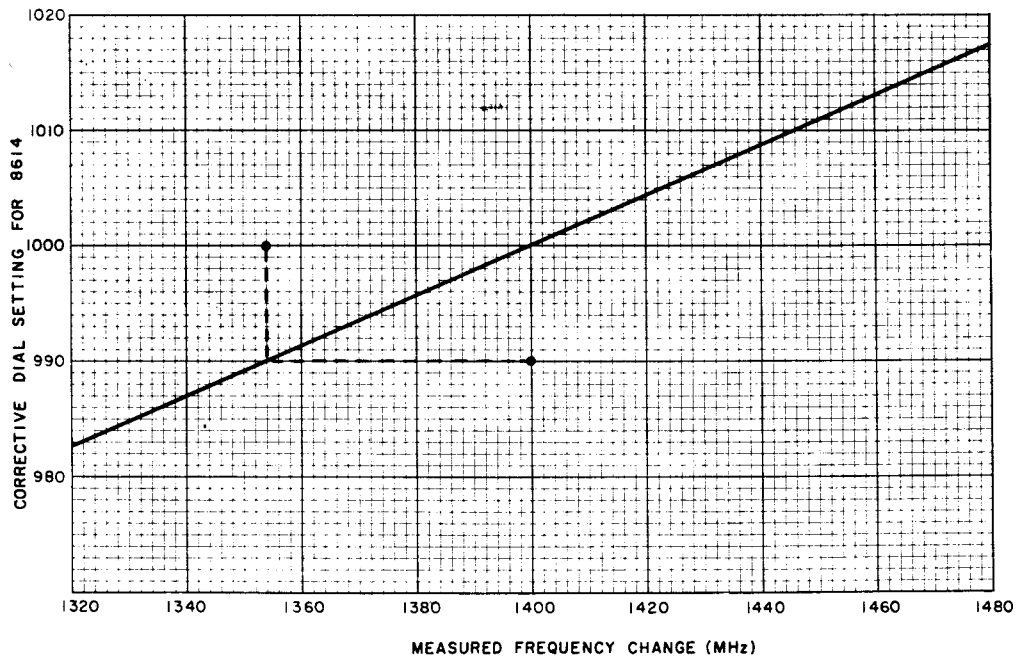

Figure 5-15. Frequency Range Spread Correction Curve

than 2400 MHz. If dial travel is not satisfactory, loosen bevel gear on frequency drive shaft and reset dial.

g. Check microswitch action: microswitch should energize and de-energize at about 1590 to 1610 MHz. If microswitch does not switch at proper dial settings, microswitch cam (located on underside of cavity casting) should be repositioned (see Figure 5-7).

h. Being careful to approach all dial settings from the same (either clockwise or counterclockwise) direction, using the procedure given in paragraph 5-11, check accuracy of frequency dial by approaching all dial settings from a clockwise direction and then from a counterclockwise direction.

NOTE

The frequency meter used must be calibrated to an accuracy of approximately $\pm 0.03\%$.

i. If frequency dial reading errors are greater than ± 5 MHz, shifting the dial may bring all errors within specification. If shifting dial will not sufficiently correct errors, it may be necessary to shift position of center conductor support rod (see Figure 5-16). The center conductor is notched at end closest to right side of instrument and may be loosened and then adjusted "in" "out" of klystron cavity. Notch or scratch center conductor rod so that original position may always be known. If overall frequency error was positive, adjust center conductor toward right side of instrument. If overall error was negative, adjust center conductor toward left side of instrument. When adjusting center conductor position, never change by more than about 20 thousandths of an inch at a time.

NOTE

If any adjustment of instrument was necessary, repeat entire check and adjustment procedure until no adjustment is required.

5-61. POWER ADJUST.

5-62. RF POWER OUTPUT ADJUSTMENT.

- a. **Front Panel Settings:** Have ALC button released (OFF). Set ATTENUATION (dB) to 012 dB. Set FREQUENCY to 800 MHz.
- b. **CAL RF Adjustment:**
 1. With a power meter, measure the CAL RF output power. It should be $-11 \text{ dBm} \pm 0.1 \text{ dBm}$.
 2. If it is not, loosen the two setscrews in the attenuator drive shaft bevel gear (see Figure 5-13 P/O Errata). With the bevel gear loose, turn the attenuator gear with your fingers until the output power is -11 dBm . Without disturbing the -11 dBm power setting, turn the attenuator knob on the front panel until the attenuator counter reads 012 dB. Tighten the two setscrews in the bevel gear.
- c. **UNCAL RF Adjustment:**
 1. Measure the UNCAL RF power output. It should be $-3 \text{ dBm} \pm 0.3 \text{ dBm}$.
 2. If it does not, the RF UNCAL probe requires adjustment. The front right side panel should be removed, exposing the probe assembly cable guide. Remove the screw in the cable guide that is in line with the UNCAL probe retaining screw (see Figure 5-13 P/O Errata). Insert a long Allen wrench through the hole left by removing the cable guide screw into the UNCAL probe retaining screw. Turn the retaining screw to adjust the UNCAL probe penetration for $-3 \text{ dBm} \pm 0.3 \text{ dBm}$ output.
- d. **ALC Adjustment:**
 1. With a dc voltmeter (HP Model 412A) measure the dc voltage at the output of the CR701 crystal diode, or the base of Q501A.

CAUTION

Do not use a digital voltmeter with Auto-Ranging as it might damage the crystal diode.

The dc voltage should be $120 \text{ mV} \pm 2 \text{ mV}$.

2. If it is not, the ALC attenuator probe requires adjustment. The front right side panel should be removed, exposing the probe assembly cable guide. Remove the screw in the cable guide that is in line with the ALC probe retaining screw (see Figure 5-13 P/O Errata). Insert a long Allen wrench through the hole left by removing the cable guide screw into the ALC probe retaining screw. Turn the retaining screw to adjust the ALC probe penetration for $120 \text{ mV} \pm 2 \text{ mV}$ at the ALC crystal output.

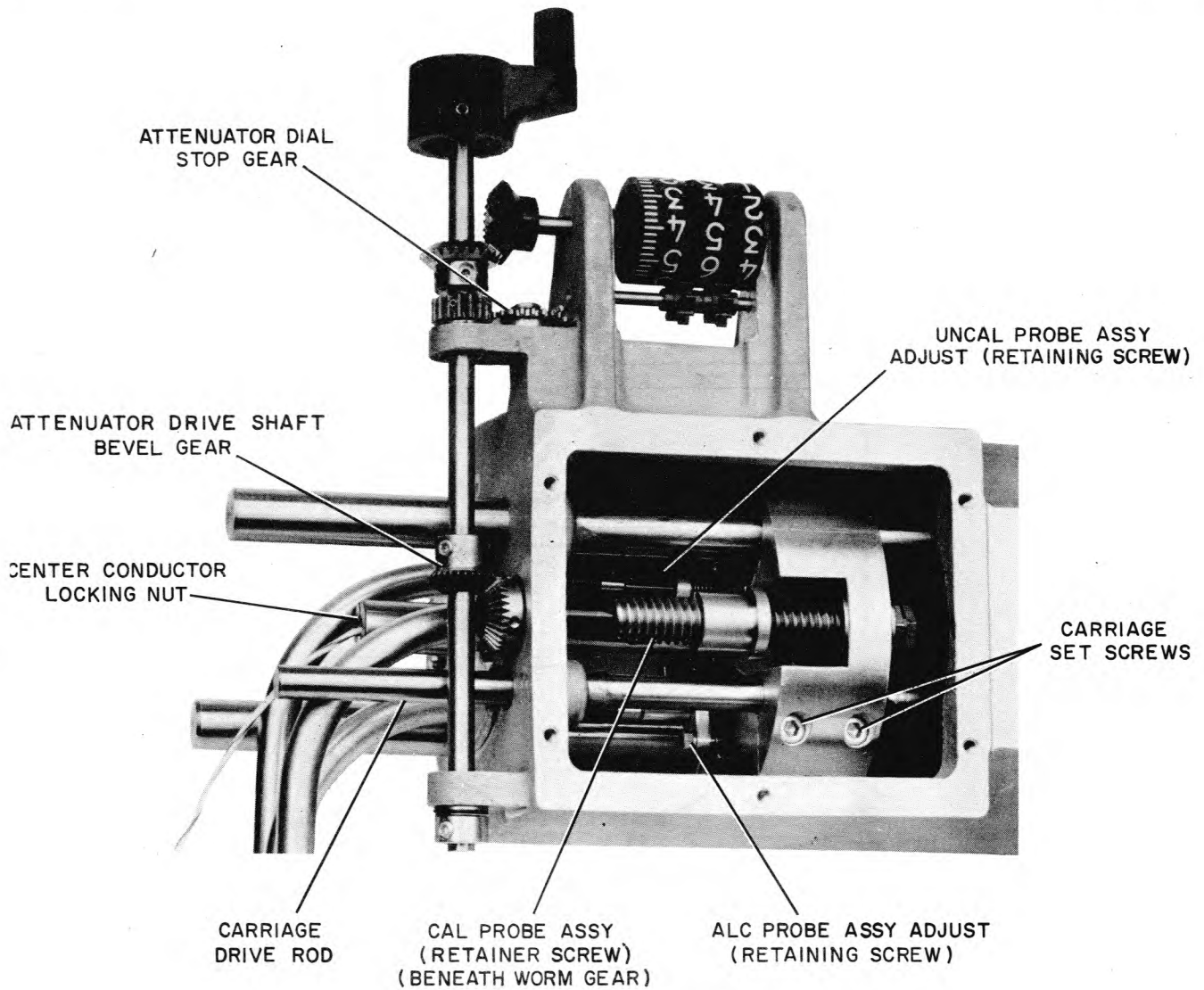

Figure 5-16. Probe Assembly Adjust

5-63. INTERNAL LEVELING ADJUST.

5-64. Replacement of the klystron should not affect internal leveling operation (ALC). However, the characteristics of the new klystrons can differ enough to require readjustment of the ALC Amplifier and the Meter Amplifier. Refer to paragraph 5-12 and check the leveled output; if adjustment is necessary refer to paragraph 5-65 for procedure.

Table 5-8. Klystron Probe Adjust

Probe for	Measuring Point	Instrument	Reading
ALC	CR701 or base of Q501A	HP 412A	120 ±2 mV
Cal Pwr	Front panel connector	HP 431A/B	-11 ±0.1 dBm
Uncal Pwr	Front panel connector	HP 431A/B	-3 ±0.3 dBm

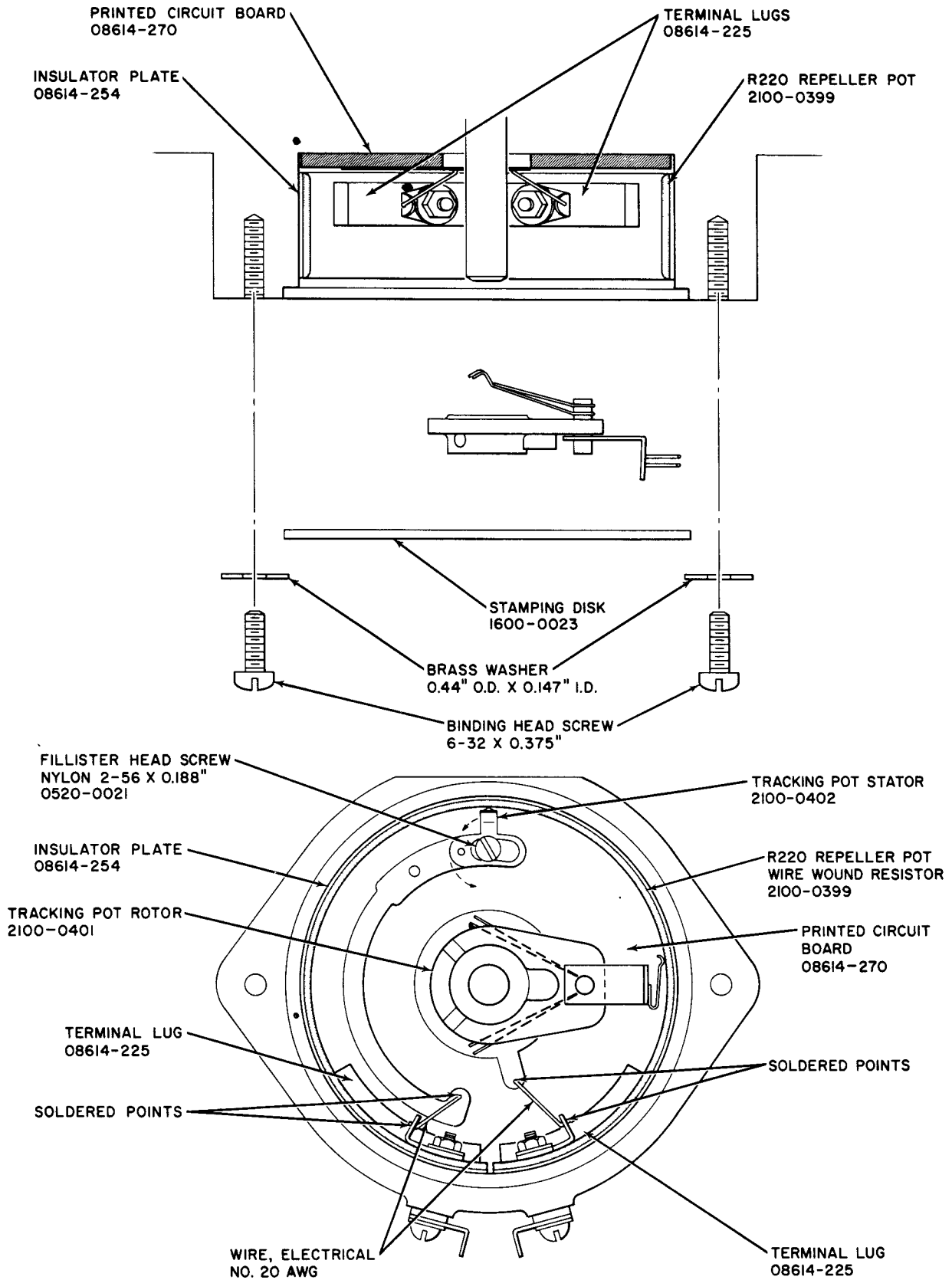

Figure 5-17. Repeller Pot Assembly

5-65. ADJUSTMENTS AFTER PIN MODULATOR REPLACEMENT.

5-66. Following replacement of a PIN modulator, certain adjustments must be made before the instrument will operate properly. The general steps in the overall procedure are as follows:

- a. Adjust Meter Amplifier.
- b. Adjust ALC Amplifier.
- c. Adjust on-off ratio.
- d. Adjust Pulse Modulation.
- e. Adjust Square-Wave Modulation.
- f. Adjust AM Response.

5-67. METER AMPLIFIER ADJUST.

a. Release RF button. Zero front-panel meter with front-panel ZERO SET.

b. Depress RF button; set frequency dial to 800 MHz.
 Note: See paragraph 5-62 and adjust ALC probe.

c. Measure meter amplifier output voltage (wire with green and violet tracers on front panel ALC switch). This voltage must be -6.4 ± 0.3 volts. This corresponds to a gain of 53 ± 2 volts.

d. Front panel DBM meter should read $+1.0 \pm 0.3$ volts.

5-68. ALC AMPLIFIER ADJUST.

a. Set FREQUENCY (MC) to 800 MHz and ATTENUATION (DB) to 012.

b. Depress ALC button and set front panel DBM meter to 0 DBM by means of ALC CAL OUTPUT knob.

c. Track ALC amplifier at CAL RF OUTPUT and adjust as indicated in Table 5-9; use a power meter and a thermistor mount or equivalent equipment.

5-69. ON-OFF RATIO ADJUST.

a. Set up Model 8614A as follows:

- LINE depressed
- ZERO SET. set DBM meter to ZERO SET
- RF depressed
- ALC CAL
- OUTPUT . full CCW for 0 dBm meter reading
- ALC depressed
- ΔF centered
- FREQUENCY (MC) 1600
- ATTENUATION (DB) 000

b. Connect power meter to CAL RF OUTPUT and adjust signal generator for a full scale reading on the 0 DBM range of the power meter.

c. With no input applied to PULSE INPUT, depress PULSE button. The CAL RF OUTPUT should drop at least 20 dBm.

Table 5-9. ALC Amplifier Adjust

Frequency	Adjust	Calibration Power Output
Low freq.	R614	-12 ± 0.2 dBm
Mid-freq. below switch	R621	-12 ± 0.2 dBm
Mid-freq. above switch	R615	-12 ± 0.2 dBm
High freq.	R620	-12 ± 0.2 dBm

Note: R614 and R621 interact as do R615 and R620. To simplify the adjustment, overcorrect with pot for frequency indicated, then back off with interacting pot. For example, the reading at 1600 MHz (below microswitch) is -10 dBm. Adjust R621 for -13 dBm, then adjust R614 for -12 dBm at 1600 MHz.

d. If the on-off ratio is not 20 dB or greater, adjust R420 for proper on-off ratio. If on-off ratio will not adjust properly, PIN modulator may be defective. Check bias current through R414 and through R420: the current through R414 should be approximately 6 mA, and the current through R420 should be 3 mA. If these bias currents are correct and CR403 is not shorted, then the modulator may be defective. Check RF Probe resistance (refer to paragraph 5-62); if resistance is OK then modulator is defective (refer to paragraph 5-47).

5-70. PULSE MODULATION ADJUST.

a. Depress PULSE button and apply an externally-generated 20-volt 4- μ sec positive pulse to front panel pulse BNC input (refer to paragraph 5-14).

b. If pulse operation is not satisfactory, adjust R420.

Note

Resistor R420 also adjusts the on-off ratio; if adjustment was necessary recheck on-off ratio (paragraph 5-69).

5-71. SQUARE-WAVE MODULATION ADJUST.

a. Depress SQ WAVE button and check square wave output on an oscilloscope (refer to paragraph 5-15).

b. Adjust R410 for best symmetry at 1000 ± 50 Hz.

c. Rotate SQ WAVE control full counterclockwise: square wave frequency should be equal to or less than 950 Hz.

d. Rotate SQ WAVE control full clockwise: square wave frequency should be at least 1050 Hz.

e. The square-wave frequency range is determined by R413 (front panel SQ WAVE control) and C402. The value of C402 is selected for proper frequency range: it may be 2250 pF, 2676 pF, or 3000 pF. Increasing the capacity decreases the upper and lower limit of the range while decreasing the capacity will increase the upper and lower limit.

5-72. AM RESPONSE ADJUST.

a. Check AM operation at about 50 Hz (see paragraph 5-16).

b. If AM waveform is not satisfactory, change value of C404 by about 10 pF and recheck operation. **Note:** typically, undistorted AM operation is achieved with either a 30- or 39-pF capacitor.

5-73. REPELLER POT (R220) REPLACEMENT.**5-74. TOOLS REQUIRED.**

- a. Small pair of wire cutters
- b. #6 allen drive wrench (hex head drive)
- c. Screwdriver with flat thin blade

5-75. PROCEDURE.

5-76. If it is necessary to replace the repeller pot (R220, a wirewound resistor), then both R220 HP Stock No. 2100-0399) and the insulator plate (HP Stock No. 08614-254) must be replaced. Use Figure 5-7 as a location guide and Figures 5-17 and 5-18 as replacement guides and proceed as follows:

- a. Remove power cord from instrument.
- b. Remove instrument bottom cover and repeller pot access cover.
- c. Loosen the two allen screws retaining the tracking pot rotor and remove rotor.
- d. Using a flat blade screwdriver to turn the nylon screw, turn the tracking pot stator a quarter turn counterclockwise.
- e. Remove hardware holding R220 in place and remove R220 and insulator plate from casting assembly.
- f. Prepare new repeller pot, R220, for installation by cutting about 1/8 inch of material off each end. Also prepare new repeller pot, R220, for installation by gently bending to take some of the stiffness out. **Note:** If resistor is bent sharply, it will break in half.
- g. Gently bend the wirewound resistor (R220) with the insulator plate behind it and insert in casting. Note the resistor must be inserted so that the "bronze colored section" contacts, or is closest to, printed circuit board.
- h. Insert retaining hardware through casting holes and wirewound resistor and insulator plate. Do not tighten wirewound resistor firmly in place as adjustment is necessary.
- i. Refer to Figure 5-17; R220 must be relatively flat against wall of casting. The resistor can be flattened against casting wall by pushing on edge, CAREFULLY, and tightening in place.

CAUTION

Do not push on R220 with a sharp metal object, such as a screwdriver, as the wire windings can be easily destroyed if the screwdriver blade slips.

j. Once R220 has been adjusted for flatness and the retaining screws firmly tightened, replace tracking pot rotor in assembly. The tracking pot rotor must be set in place so that contact is made with inner printed circuit board ring at all times. Also, the rotor contact with resistor must be uniform with contact made as illustrated in Figure 5-17: only the curved end of the contacts may touch the repeller pot at any point.

k. Using a flat blade screwdriver to turn the nylon screw, turn tracking pot stator back to original contacting position as illustrated in Figure 5-17.

m. Set FREQUENCY(MC) front panel dial to 1600 and note position of repeller tracking pot rotor: the tracking pot rotor resistor contacts should be positioned almost exactly above the tracking pot stator.

n. Watching the tracking pot rotor to be sure that it does not hit either terminal lug (HP Stock No. 08614-225), very slowly rotate FREQUENCY(MC) front panel dial from one end of travel to the other. If necessary, adjust terminal lug and tracking pot rotor position to ensure that tracking pot rotor will not contact either terminal lug.

p. Replace the stamping disc (repeller pot access cover) and tighten in place with the two binding-head screw.

Note

When placing the stamping disc, be sure that it does not contact the repeller pot resistor. If it does, repeat above procedure and adjust repeller pot resistor position.

q. Refer to paragraph 5-57 and check all listed adjustments.

Note

Do not change an operating voltage or calibration adjustment unless it is definitely outside specified tolerance or accuracy of a dependent function is unsatisfactory. Improving a marginal adjustment can adversely affect calibration.

5-77. LOW PASS FILTER REPLACEMENT.**5-78. TOOLS REQUIRED.**

- a. Soldering Equipment (see Table 5-7).
- b. Small pair needle nose pliers.
- c. Small pair pliers.

5-79. PROCEDURE.

5-80. Figure 5-19 illustrates Low Pass Filter and ALC Crystal diode (CR701) parts with stock numbers. The illustration is an assembly drawing. Part removal is the reverse of illustrated assembly instructions. The first step for disassembly is to unsolder the cable to Low Pass Filter and grounding lug connections. The last step of assembly is to solder the cable to Low Pass Filter and grounding lug connections.

CAUTION

Before touching CR701 refer to paragraph 5-49, Step c - Caution.

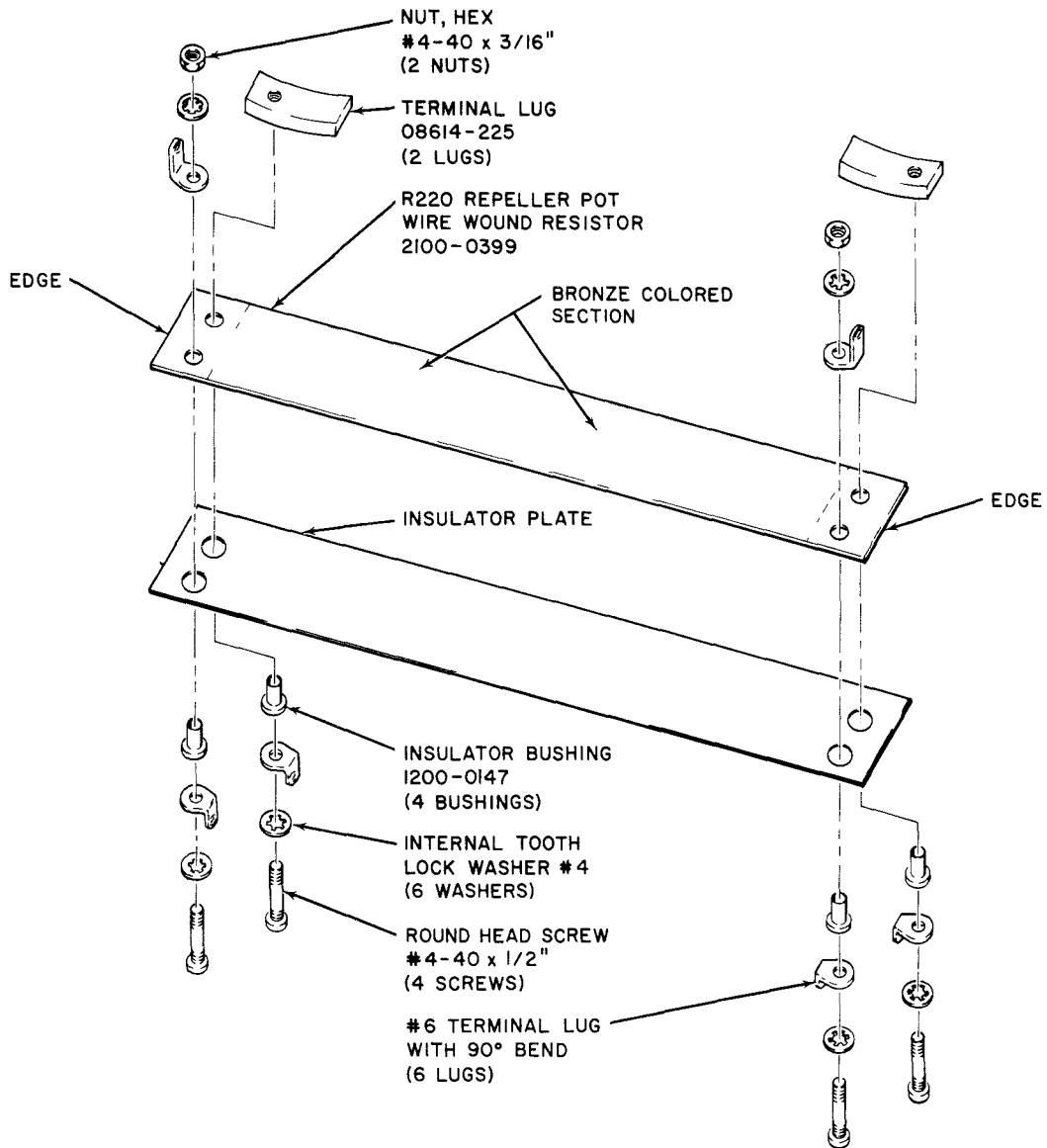
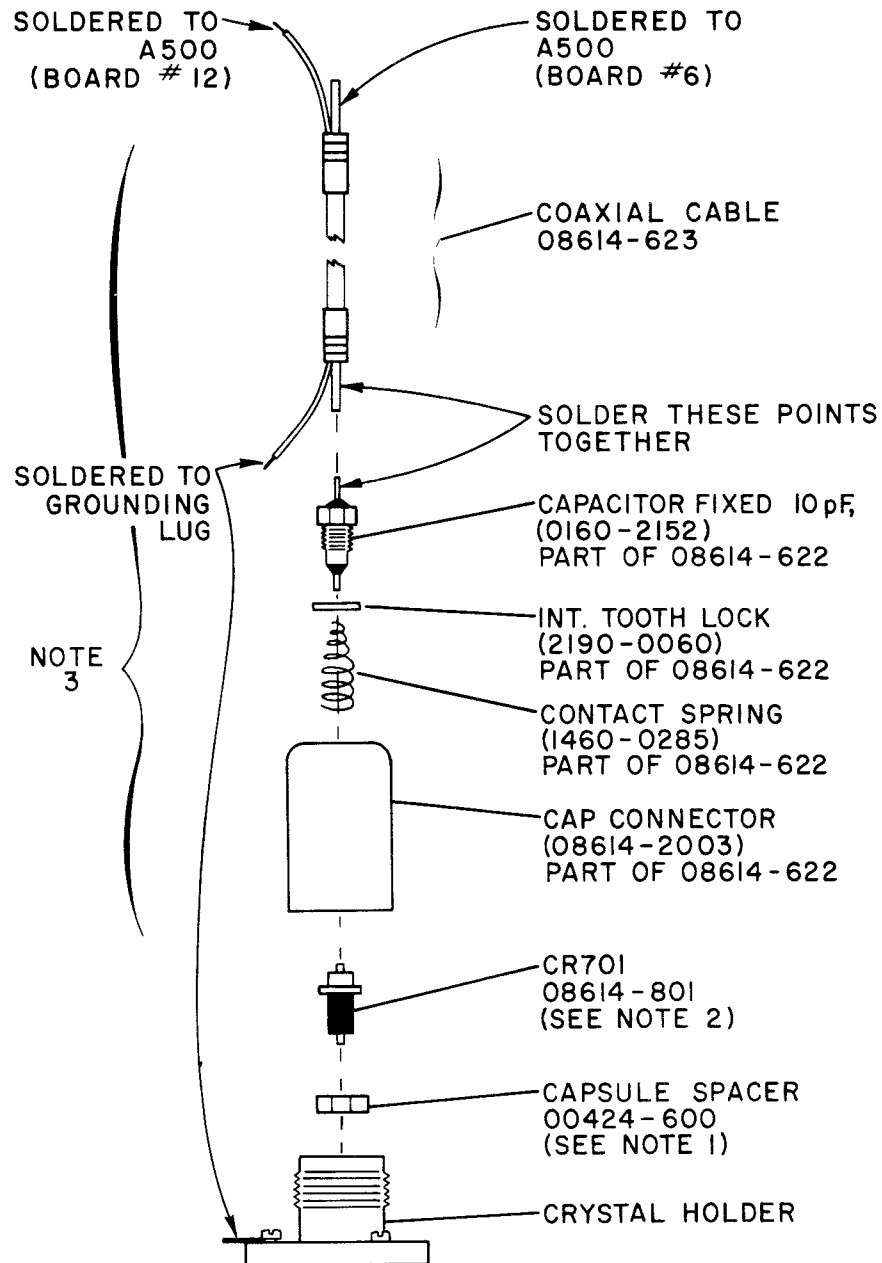

Figure 5-18. R220 Repeller Resistor Assembly



1. CAPSULE SPACER INCLUDES POLYIRON INSERT WHICH MUST ALWAYS BE INSERTED SO THAT INSERT WILL CONTACT WITH CRYSTAL HOLDER (POLYIRON DOWN).
2. STOCK NO. 08614-801 INCLUDES A SPECIAL MATCHING RESISTOR, R519, THAT MUST BE REPLACED WHEN EVER CR701 IS REPLACED.
3. COAXIAL CABLE AND ALC FILTER ASSEMBLY PARTS ARE AVAILABLE AS PART OF LOW PASS FILTER KIT *hp* STOCK NO. 08614-625.

Figure 5-19. Low Pass Filter Assembly Drawing

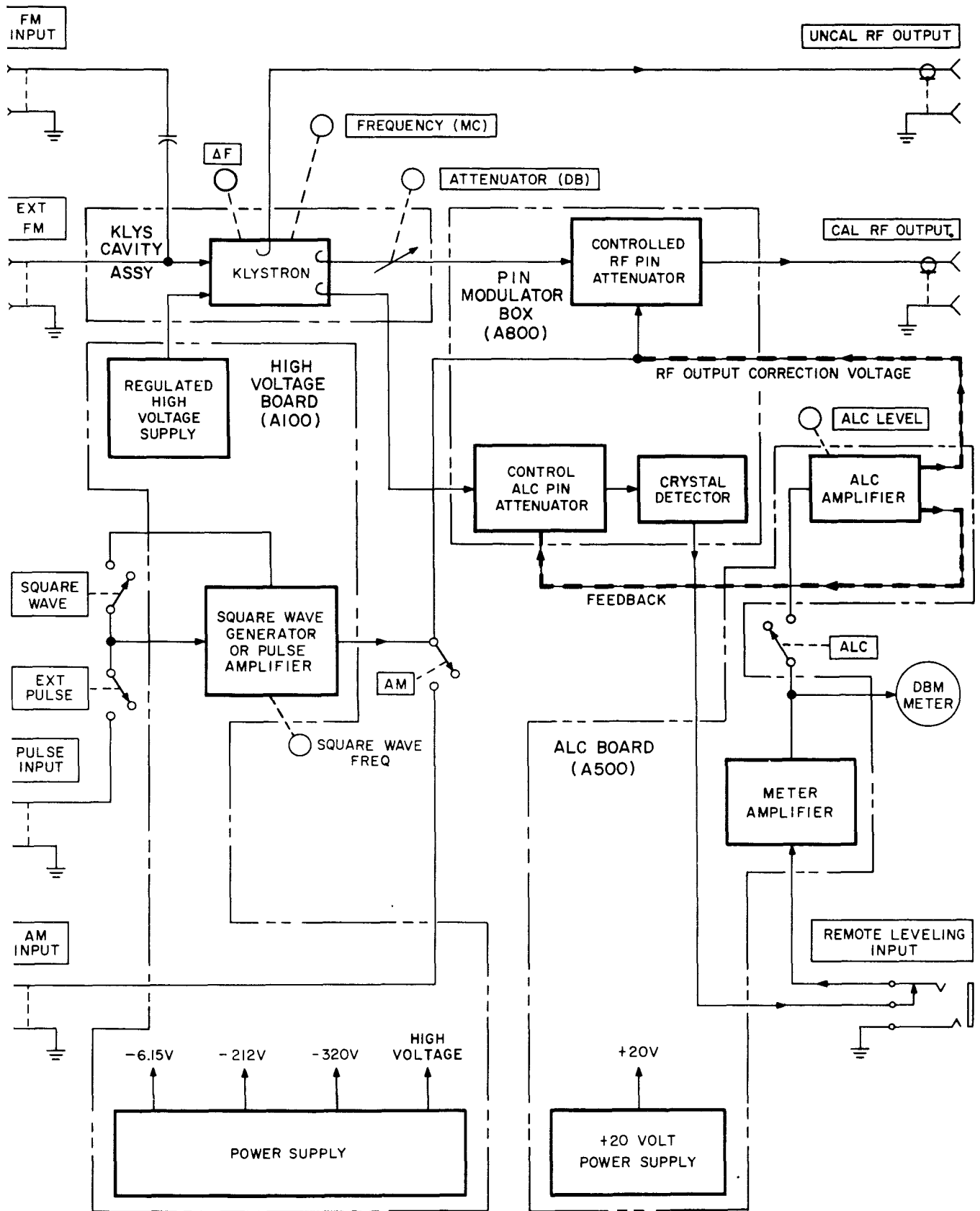

Figure 5-20. Instrument Block Diagram

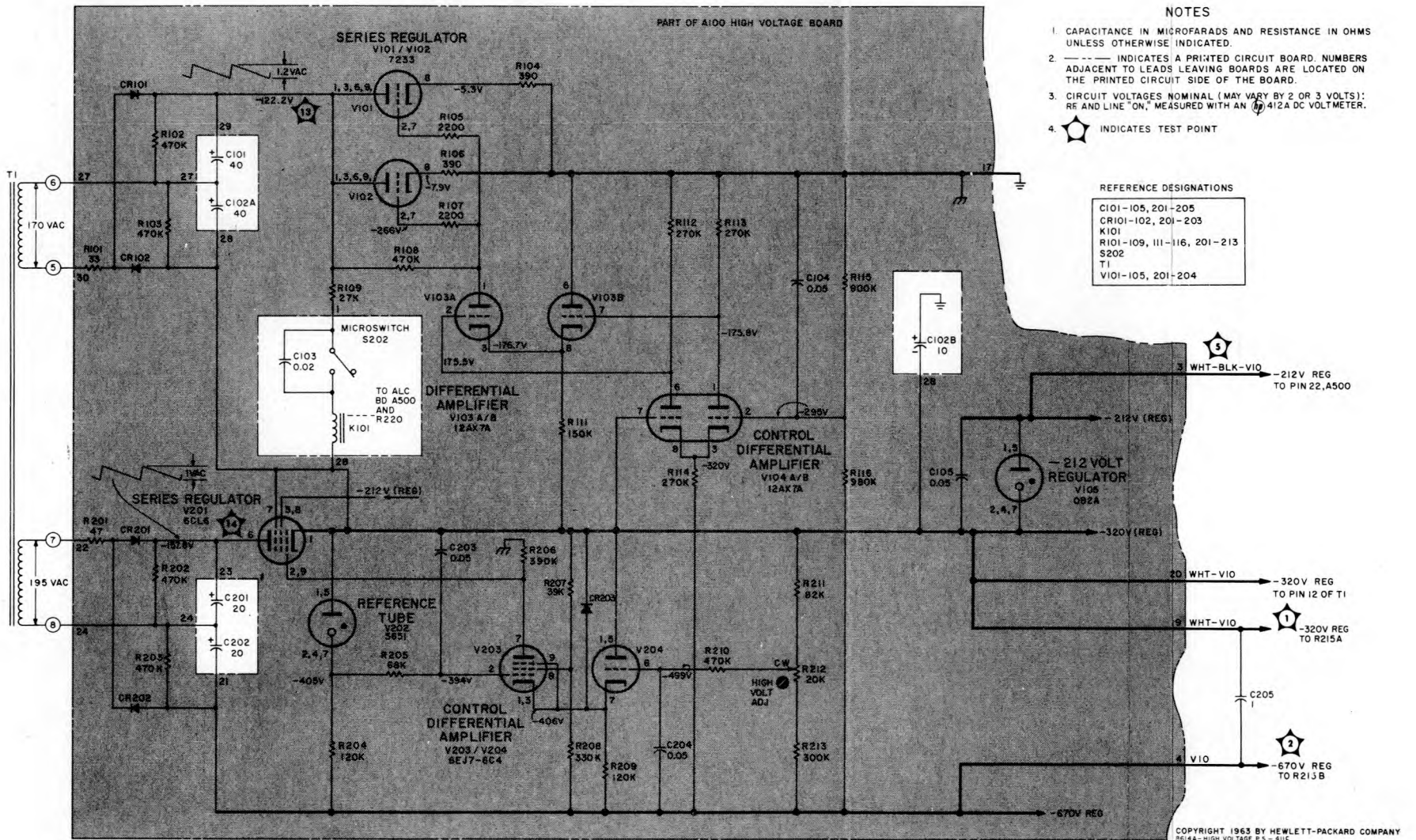

Figure 5-22. High-Voltage Power Supply

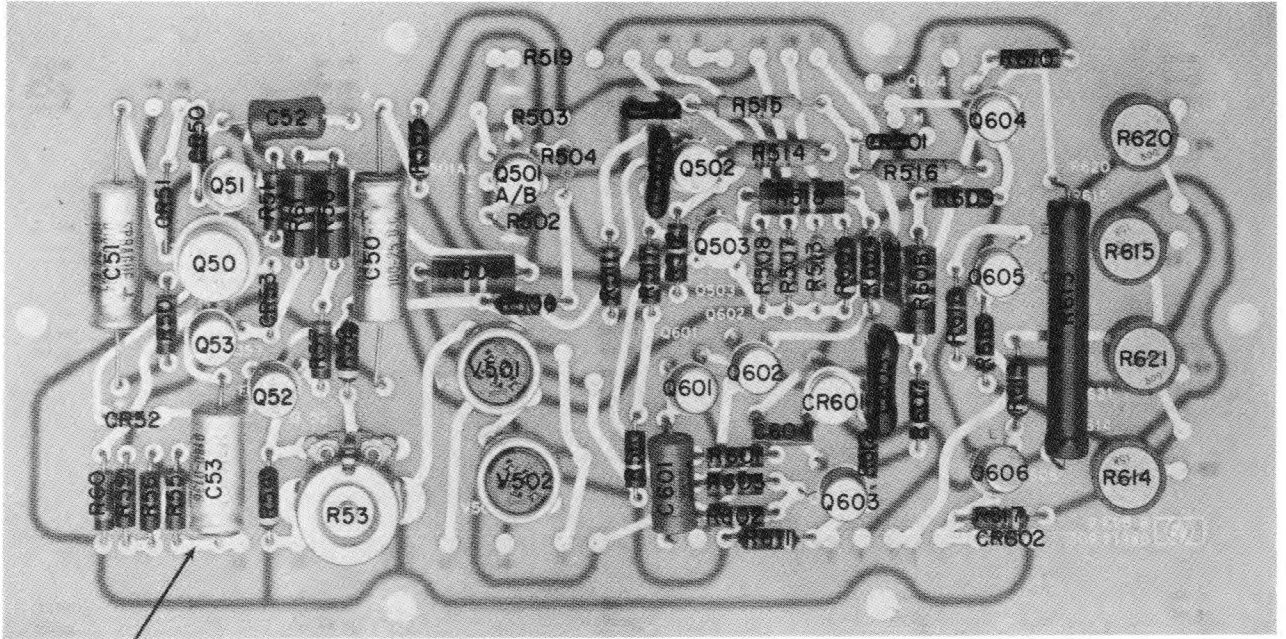

Figure 5-23. ALC Board (A500)

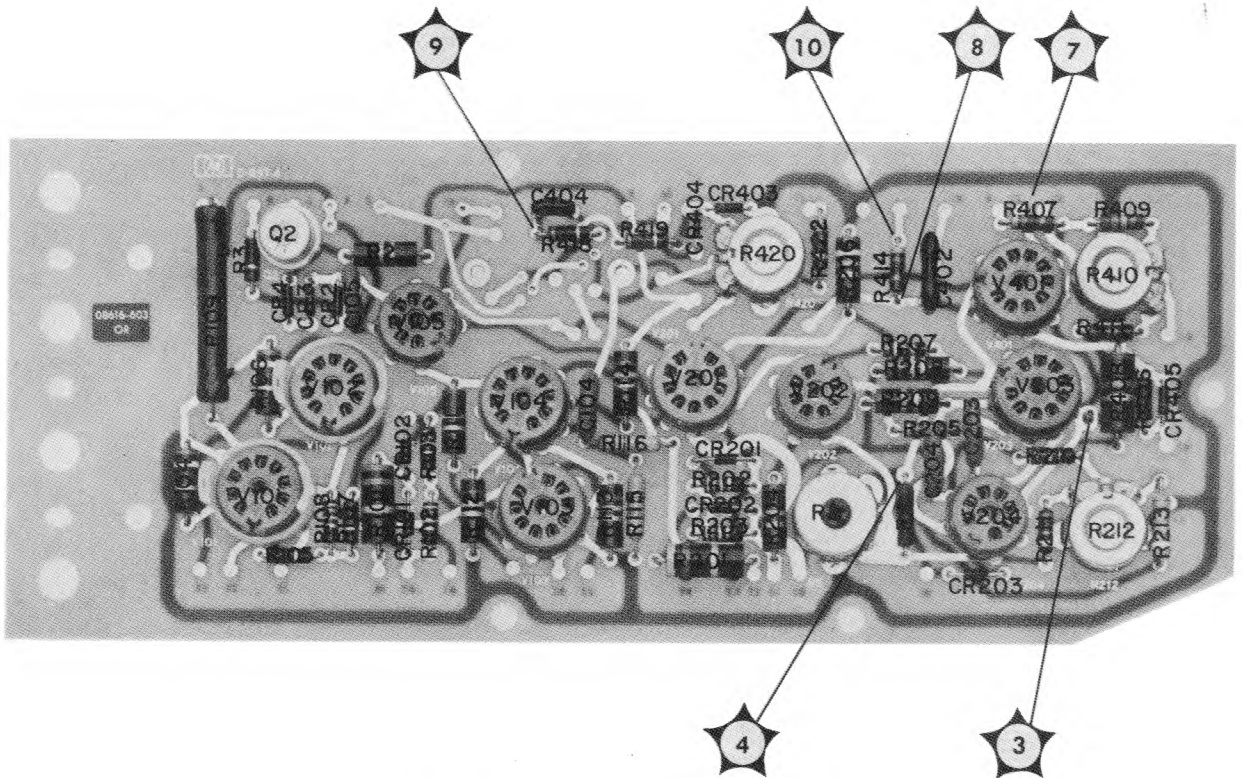
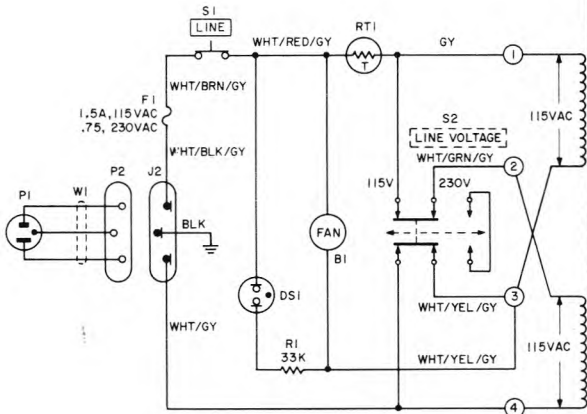

Figure 5-24. High-Voltage Board (A100)

REFERENCE DESIGNATORS

A100, A500
B1
C1-2, C50-53
DS1
F1, 2
J2
P1, 2
Q1-2, Q50-53
R1-5, R50-61
RT1
SI, 32
WI



NOTES:

1. RESISTANCE IN OHMS; CAPACITANCE IN MICROFARADS UNLESS OTHERWISE INDICATED.
2. ALL SWITCHES SHOWN IN THE "ON" POSITION.
3. --- -- --- INDICATES PRINTED CIRCUIT BOARD. THE NUMBER ADJACENT TO LEADS LEAVING THE BOARD ARE LOCATED ON THE PRINTED CIRCUIT BOARD SIDE.
4. ⦿ INDICATES SCREWDRIVER ADJUSTMENT.
5. CW INDICATES POSITION OF ADJUSTABLE CONTACT AT THE LIMIT OF CLOCKWISE TRAVEL IS VIEWED FROM THE KNOB END OF THE POTENTIOMETER.
6. ☆ INDICATES TEST POINT

COPYRIGHT 1963 BY HEWLETT-PACKARD CO.
8614A-FIL-SUP-331F

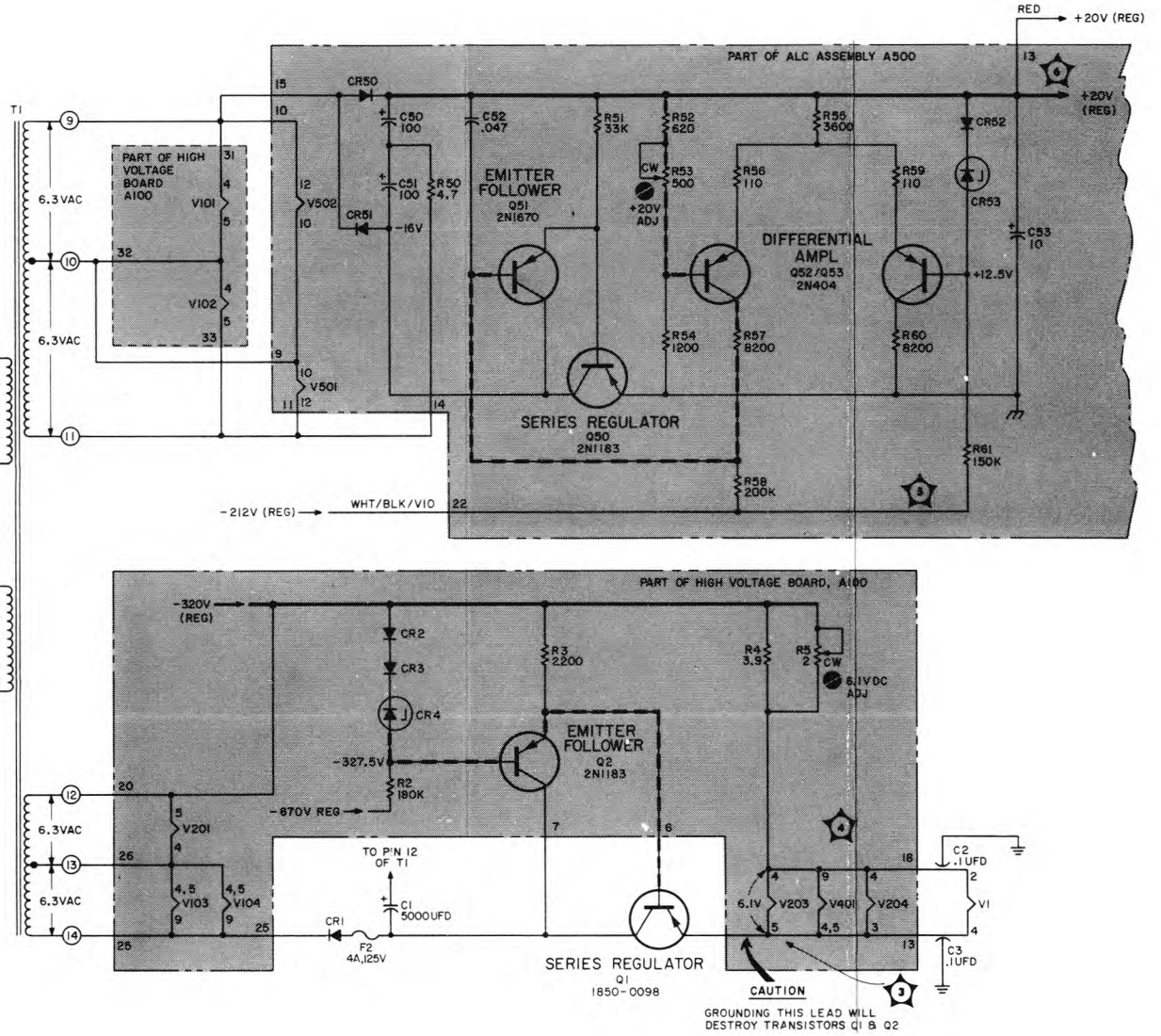

Figure 5-25. Regulated +20 Volt and Filament Supplies

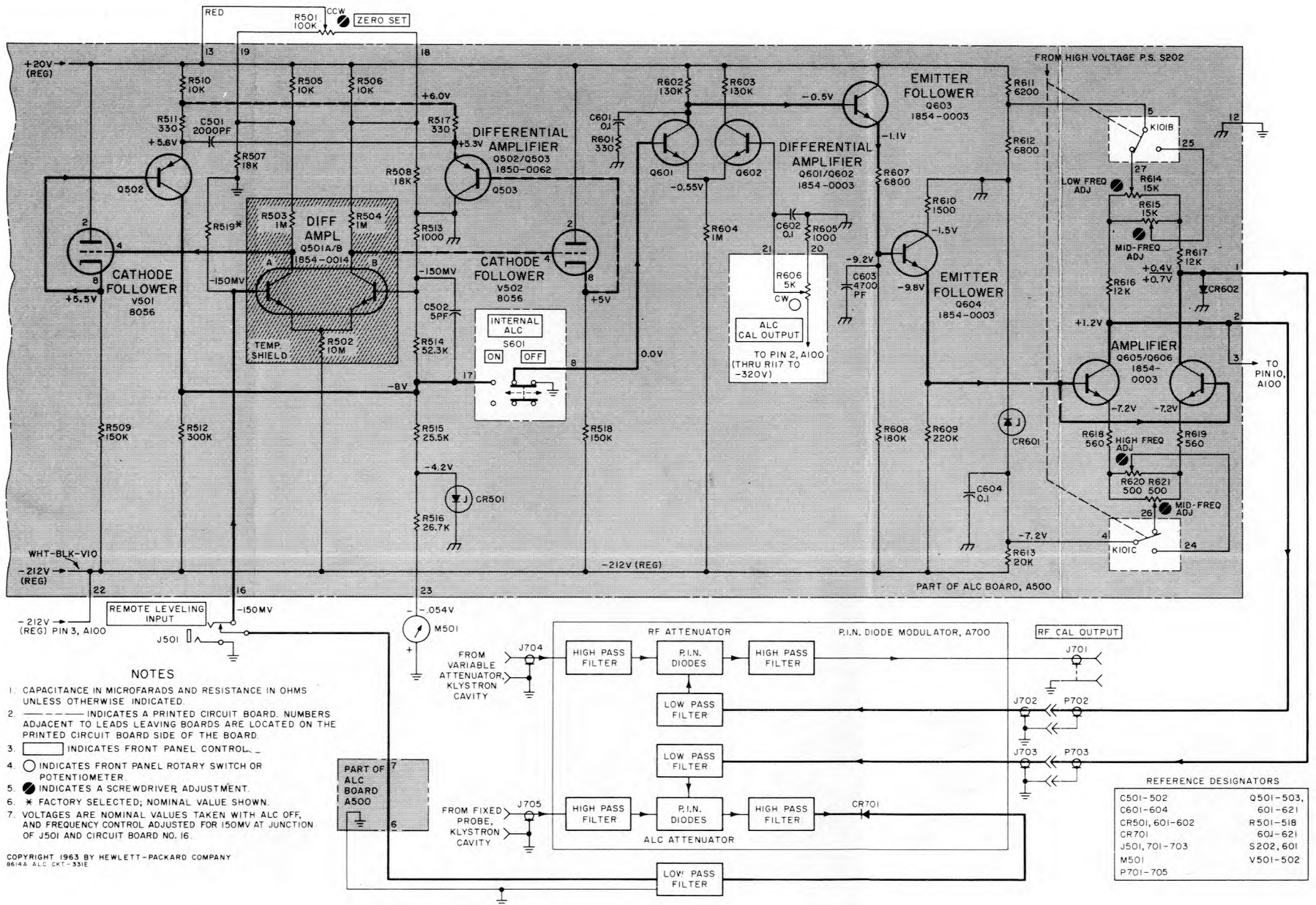

Figure 5-27. ALC Circuit

5-35/5-36

APPENDIX

BACKDATING

MANUAL CHANGES

Model 8614A
Signal Generator

Make all backdating corrections in this manual according to changes below.

SERIAL PREFIX OR NUMBER	MAKE MANUAL CHANGES	SERIAL PREFIX OR NUMBER	MAKE MANUAL CHANGES
331-	A through R	511-	J through R
343-	B through R	548-	K through R
351-	C through R	548-below 01350	L through R
408-	D through R	748-below 01850	M through R
411-	E through R	749-below 01900	N through R
424-	F through R	749-below 01950	O through R
434-	G through R	749-below 02000	P through R
448-	H through R	815-below 02100	Q, R
501-	I through R	815-below 02201	R

CHANGE A: R109 is a 27K-ohm, 4-watt resistor. The 4-watt rating is very close to operating power and should be changed to a 27K-ohm, 5-watt resistor (listed value Table 6-1) if replacement is ever necessary.

CHANGE B (see Note 1): Figure 2 (see Change F): Delete L1, connected in series with capacitor C4 and switch S3 (replace with a short circuit).

NOTE 1

Some 6BM6 klystrons were manufactured with a low-beam current characteristic. These low-beam current klystrons would sometimes fail to start oscillating between 1500 MHz and 1600 MHz when the 8614A RF button was depressed. The following modification of your 8614A will provide reliable starting of oscillations.

- 1) Move lead between cathode of klystron V1 and center conductor on S3 to OFF side of S3; i. e., toward instrument panel.
- 2) Connect L1, a 5-mH inductor between OFF side of S3 and center conductor terminal of S3.

CHANGE C: Wiring of FM-input circuitry has been accomplished as shown below.

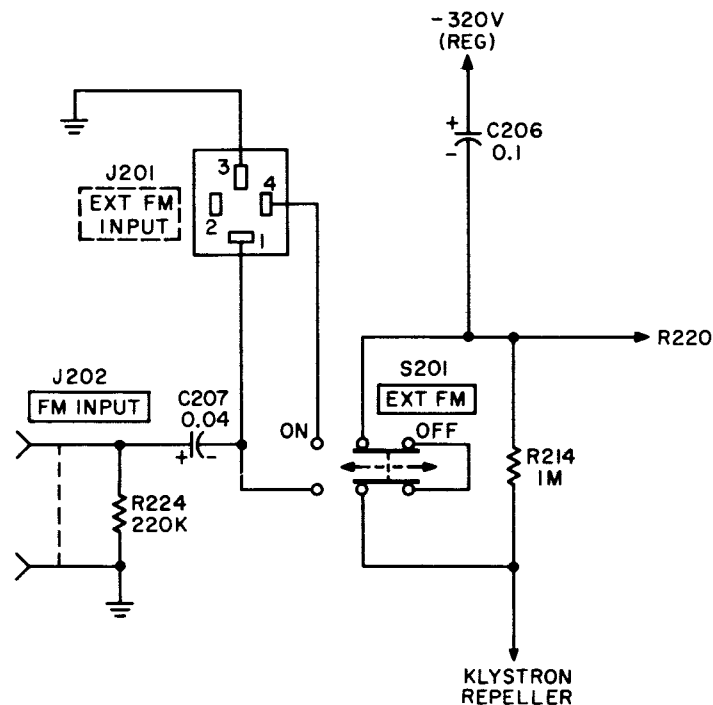

CHANGE D: Probe Carriage Assembly (HP Stock No. 08614-265) supports the wiper fingers in the cavity assembly. Should the need arise for replacement of wiper fingers it is recommended that the instrument be returned to the Hewlett-Packard Company or your local Sales and Service Office and the entire Probe Carriage Assembly be replaced with the new version (HP Stock No. 08616-218).

CHANGE E: Not applicable (deleted)

CHANGE F: Page 1-0, Figure 1-1,
The 8614A picture is in error; the physical position of the "AM" and "FM" buttons is reversed.

Section III, Figures 3-1 thru 3-8,

The physical position of the "AM" and "FM" buttons and their respective input BNC connectors is reversed.

Figure 5-21 and Figure 5-24, High-Voltage Board (A100),

Replace with component location and test point picture, Figure 1 (shown in this Appendix)

Figure 5-7, High Voltage Test Point Location,

Delete test points 1 and 2 and C205. Note that test points 1 and 2 and C205 are shown in Figure 1.

Figure 5-22, High-Voltage Power Supply,

Capacitor C205 is shown to be located off the circuit board. It should be shown to be within the circuit board outline: electrical connections are unchanged.

Resistor R212: Change from 50K to 20K.

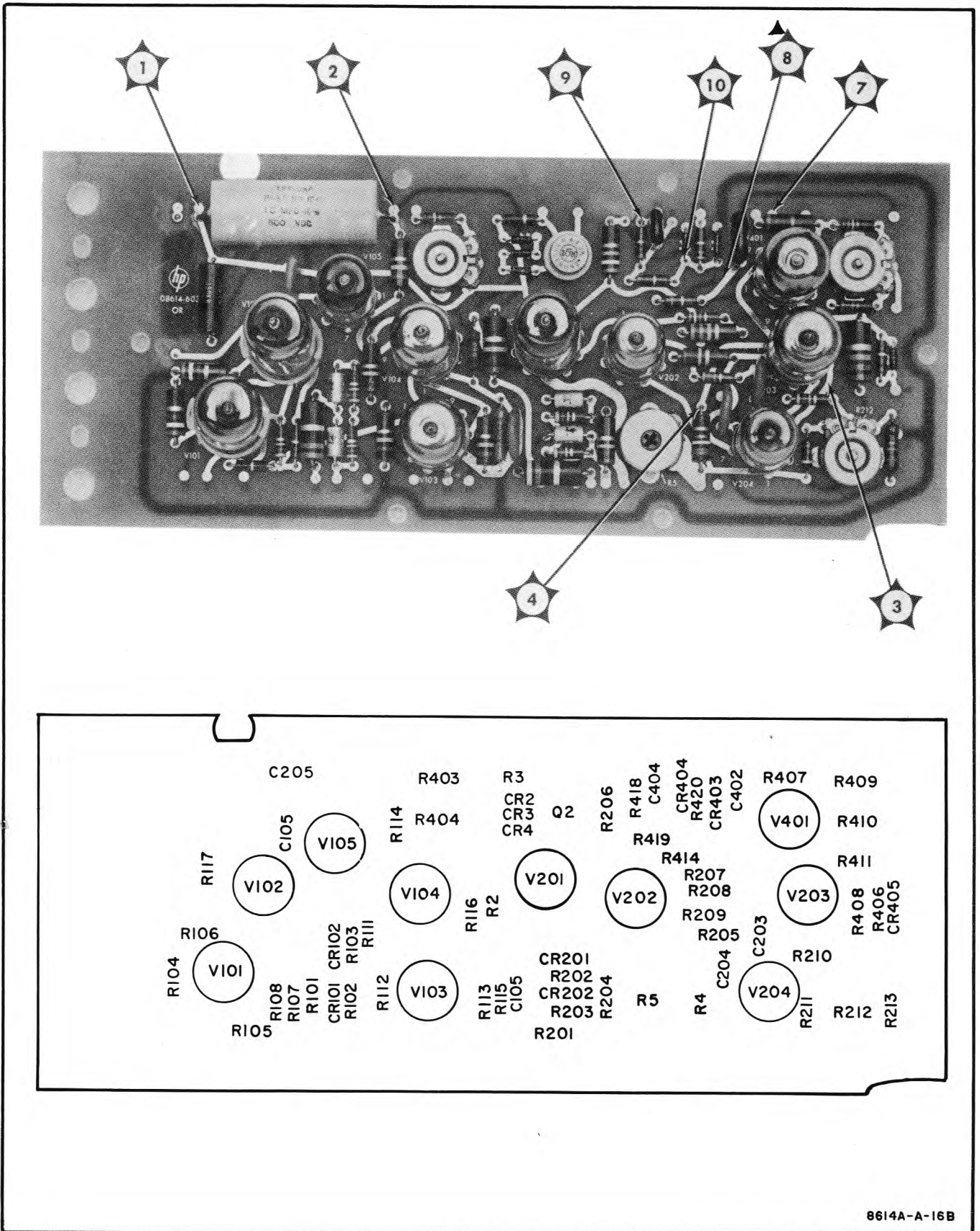

Figure 1. High Voltage Board (A100)

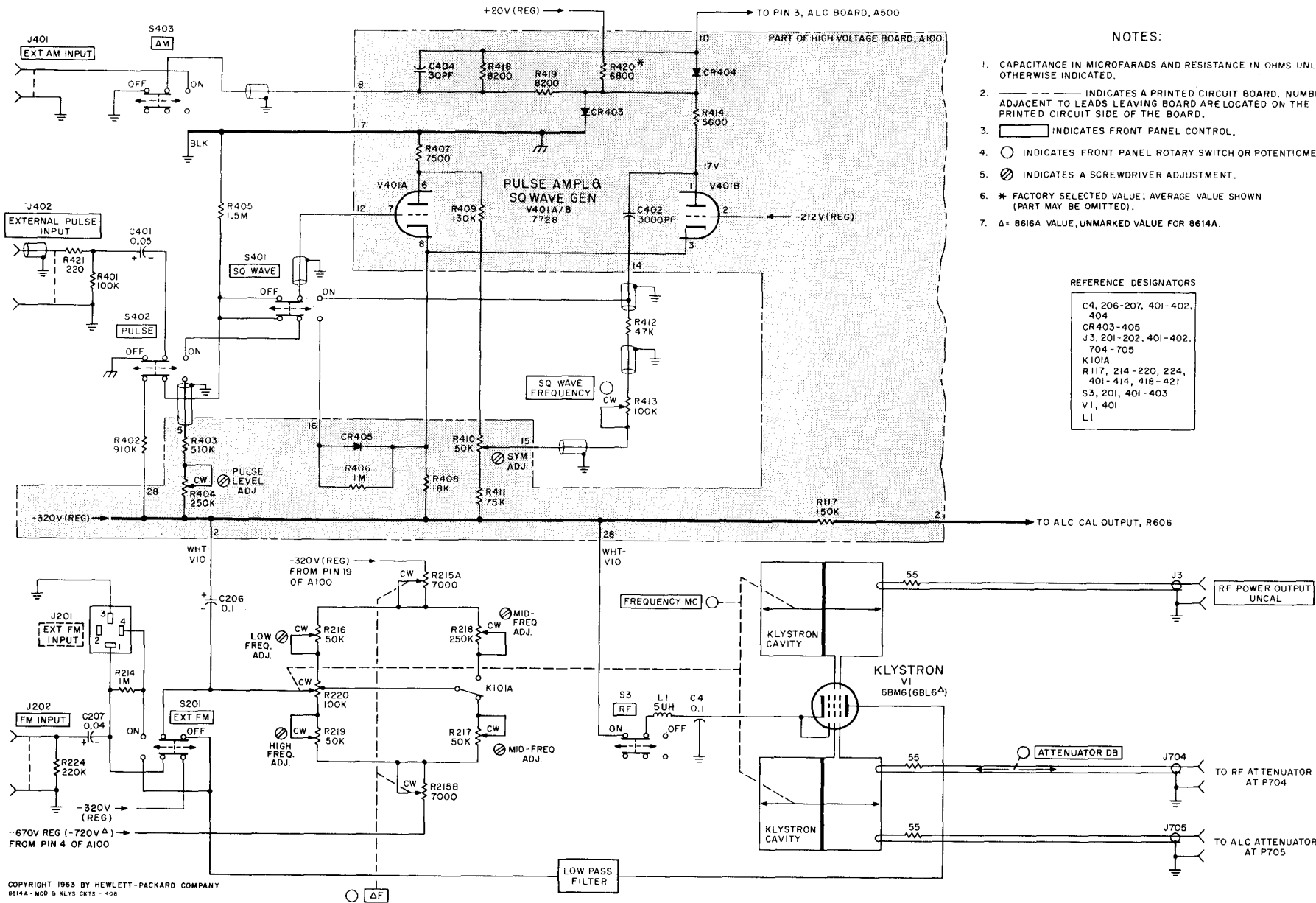

Figure 2. Modulation and Klystron Circuits

**CHANGE F:
(Cont'd)**

Page 5-21, paragraph 5-69, step d,

Change to read: "If on-off ratio is not 20 dB or greater, adjust R404 (refer to Figure 1) for proper on-off ratio. If on-off ratio will not adjust properly, PIN modulator may be defective. Check bias current through R414 and R420: the current through R414 should be approximately 6 mA, and the current through R420 should be approximately 3 mA. If current through R414 is correct but current through R420 is about 1 mA more or less than it should be, changing R420 to a higher or lower resistance may solve the problem. If these bias currents are correct and CR403 is not shorted, then the modulator or the RF probes are defective. Check RF Probe resistance (refer to paragraph 5-62); if resistance is OK then modulator is defective (refer to paragraph 5-47)."

Page 5-21, paragraph 5-70, step b,

Change to read: "If pulse operation is not satisfactory, slight adjustment of R404 and a change in the resistance of R420 may be necessary."

NOTE

Resistor R404 and the resistance value of R420 also adjust on-off ratio; if adjustment is necessary, recheck on-off ratio."

Figure 5-26, Modulation and Klystron Circuits,

Use included component location picture, Figure 2, in place of Figure 5-24.

CHANGE G Figure 5-26, Modulation and Klystron Circuits,
(see Note 2): Delete: R700, connected between S402 and ground and replace with a short circuit.

NOTE 2

Resistor R700 is a necessary component in the pulse input circuitry of the 8614A if a low impedance output solid state pulse source is to be used. Without R700, a stored potential of about 200 volts dc may be discharged into the output of such a pulse source when the 8614A PULSE button is released.

CHANGE H: Page 1-0, Table 1-1, Specifications,
Attenuator Accuracy: Change to read "+0, -3 dB from 0 to -10 dBm; ± 0.2 dB ± 0.06 dB/
10 dB from -10 to -127 dBm; direct reading dial, 0.2 dB increments"
RF Output Power Accuracy (with respect to attenuation dial): Change . . . "(-15 to
-127 dBm) . . . " (-10 to -127 dBm) . . . "

Page 3-3, Figure 3-3, Instruction 5, last line, Change "-15 dB" to "-10 dB".

CHANGE I: Page 4-3, Figure 4-5,
R402: Change from 390K to 39K.
R403: Change from 6.8M to 470K.

Page 5-31/5-32, Figure 5-26,
C401: Change from 0.1 to 0.05
R402: Change from 390K to 39K
R403: Change from 6.8M to 470K

CHANGE J: Not applicable (deleted)

Page 5-33/5-34, Figure 5-27,
Change as shown in partial schematic (Figure 3 Partial) shown at end of this appendix.

Section V
Delete: Paragraphs 5-76 through 5-79 and Figure 5-19.

- CHANGE J: Page 5-13, Paragraph 5-49, Step d and Page 5-14, Paragraph 5-50, Step h,
(Cont'd) Delete at beginning of both steps: "Referring to Figure 5-26 and Paragraph 5-79."
Figure 5-25 and Parts List:
Change Q51 stock number from 1850-0128 to 1850-0078.
- CHANGE K: Figure 5-26 and Parts List:
Change R215 stock number from 2100-2140 to 2100-1549.
- CHANGE L: Figure 5-25 and Parts List:
Delete fuse, F2, 3A, slo-blow, Stock No. 2110-0029.
Figure 5-22 and Parts List:
Delete breakdown diode CR203, 100V, 1 watt, Stock No. 1902-0175.
Figure 5-21 and 5-24, High-Voltage Board (A100), Replace with Figure 4 of this Appendix.
Parts List:
Delete under F2 listing: Fuseholder, Stock No. 1400-0008.
- CHANGE M: Not applicable (deleted)
- CHANGE N: Figure 5-25 and Parts List:
(Refer to CHANGE L.) For instrument serials 749-below 01950 change F2 from 4A 125V,
slo blow, stock number 2110-0014 to 3A, 125V Stock Number 2110-0029.
- CHANGE O: Figure 5-26 and Parts List:
Delete resistor R6, 0757-0059, 1 meg $\pm 1\%$, 1/2W.
- CHANGE P: Table 1-1 and Paragraph 5-12:
Change the Leveled Output specification from ± 0.75 dB to ± 0.5 dB.
- CHANGE Q: Figure 5-25 and Parts List:
Change Capacitor C1 from 5000 μ fd, Stock No. 0180-0213 to 2800 μ fd, Stock No. 0180-0128.
- CHANGE R: Figure 5-26 and Parts List (A100 Assy):
Change capacitor C404 on A100 Assy from 60 pF, HP Stock No. 0140-0214 to C404*, 30 pF,
HP Stock No. 0160-0181, factor selected part.

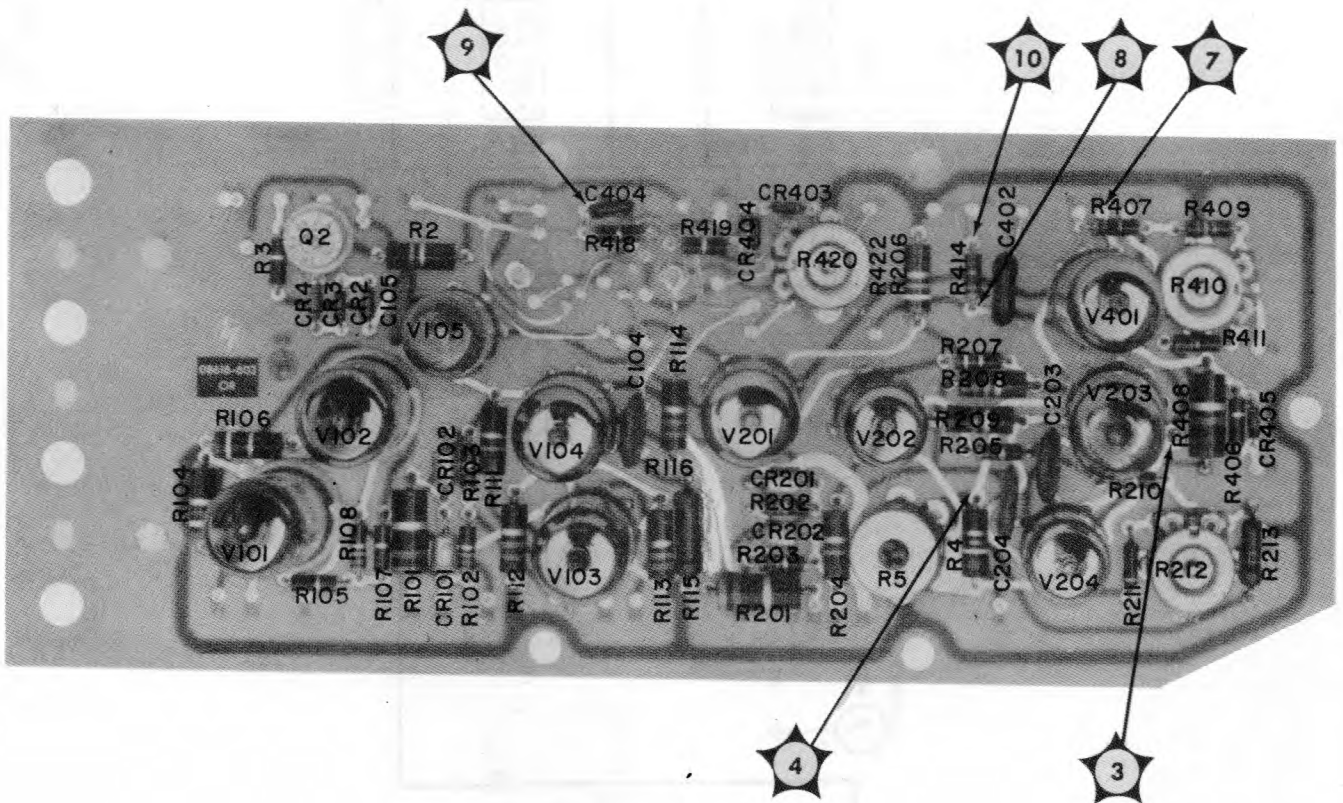

Figure 4. High Voltage Board (A100)

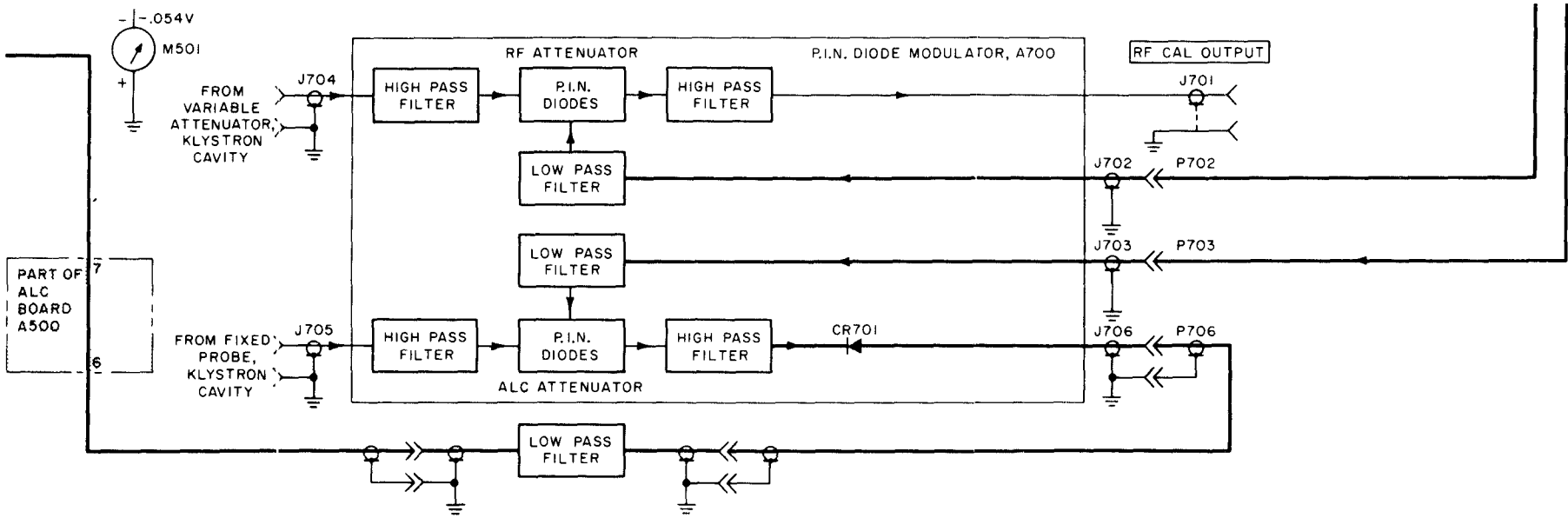

Figure 3. Partial Schematic