

As you are now the owner of this document which should have come to you for free, please consider making a donation of £1 or more for the upkeep of the (Radar) website which holds this document. I give my time for free, but it costs me around £300 a year to bring this document to you. You can donate here <https://blunham.com/Radar>, thank you.

Do not upload this copyright pdf document to any other website. Breaching copyright may result in a criminal conviction and large payment for Royalties.

This document was generated by me, Colin Hinson, from a document held at R.A.F. Henlow Signals Museum which is believed to be out of copyright or Crown Copyright. It is presented here (for free) under the Open Government Licence (O.G.L.) if under Crown Copyright and this version of the document is my copyright (along with the Crown Copyright) in much the same way as a photograph would be. It should be noted that most of the pages are identifiable as having been processed by me. If you believe the original document to be under copyright, please contact me.

The document should have been downloaded from my website <https://blunham.com/Radar>, or any mirror site named on that site. If you downloaded it from elsewhere, please let me know (particularly if you were charged for it). You can contact me via my Genuki email page: <https://www.genuki.org.uk/big/eng/YKS/various?recipient=colin>

You may not copy the file for onward transmission of the data nor attempt to make monetary gain by the use of these files. If you want someone else to have a copy of the file, point them at the website (<https://blunham.com/Radar>). Please do not point them at the file itself as it may move or the site may be updated.

I put a lot of time into producing these files which is why you are met with this page when you open the file.

In order to generate this file, I need to scan the pages, split the double pages and remove any edge marks such as punch holes, clean up the pages, set the relevant pages to be all the same size and alignment. I then run Omnipage (OCR) to generate the searchable text and then generate the pdf file.

Hopefully after all that, I end up with a presentable file. If you find missing pages, pages in the wrong order, anything else wrong with the file or simply want to make a comment, please drop me a line (see above).

If you find the file(s) of use to you, you might like to make a donation for the upkeep of the website – see <https://blunham.com/Radar> for a link to do so.

Colin Hinson

In the village of Blunham, Bedfordshire, UK.

AIR PUBLICATION
116E - 0232 - I
(formerly AP.2922E Vol. I
2nd Edn.)

GROUP 116: RADIO
SUB-GROUP E: RADIO COMMUNICATIONS (GROUND)

**TRANSMITTER, TYPES T.10197A,
T.10197B, T.15086, T.15086A
(MARCONI TYPES HS71 & HS71A)**

GENERAL AND TECHNICAL INFORMATION

BY COMMAND OF THE DEFENCE COUNCIL

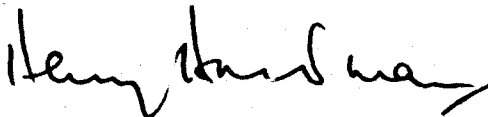

(Ministry of Defence)

FOR USE IN THE
ROYAL AIR FORCE

(Prepared by the Ministry of Aviation)

9 kW I.S.B. TRANSMITTERS
Types HS71, HS71A and HS71/1

AP.116E-0232-1

©
A.L.5 Apr. '67

THE MARCONI COMPANY LIMITED
CHELMSFORD
Printed in Great Britain

1967

P R E F A C E

1. This Technical Manual is intended to ensure satisfactory operation of Marconi equipment over its working life. It is intended for use by skilled technicians who have had adequate basic training in this general type of equipment, and does not aim to provide information for basic training. This type of information is only included where new or complicated techniques are used. Those sections dealing with day to day operation are, however, specially written with the needs and experience of operating staff in mind.
2. Marconi Technical Manuals are divided into two parts. Part 1 includes the technical description of the equipment; Part 2 covers operation and maintenance. The parts are divided into chapters; each chapter is sub-divided into numbered paragraphs. Illustrations and circuit diagrams are normally located at the end of the chapter to which they relate. Each manual includes consolidated lists of those parts which are replaceable in the event of failure. These lists, which are cross-referred to the individual diagrams, define each part fully in terms of a Marconi part reference number and, where known, a NATO stock number. It is emphasized that, where a Vol. 3 to the A.P. exists, the consolidated parts lists in this Vol. 1 are not to be used for ordering spares. The Vol. 3 is authoritative and the necessary Vol. 3 information must be quoted when ordering replacement parts.
3. This manual includes an amendment record sheet. Amendments will normally be by issue of replacement pages and drawings. On these, changes in the text will be indicated by means of a heavy line in the margin alongside the amended material.
4. The equipment covered by this manual is subject to modification control. The Modification State of the Equipment sheet defines the modification zones into which the equipment is divided, and shows the modification state of each zone to which the manual relates. Modification Summaries for each Modification Zone are to be found in the following pages. These are provided for information only.



(41842)

AL2 to
AP2922E
Vol.1 Edn.2

Transmitter Type HS71 or HS71A



59661

TRANSMITTER TYPE HS71/1

AP.116E-0232-1
A.L.5 Apr. '67

CONTENTS

		Page
1	INTRODUCTION	1
2	TECHNICAL SUMMARY	2
	2.1 Salient Features	2
	2.2 Performance	2
3	EQUIPMENT LIST	4A
4	GENERAL DESCRIPTION	4B
	4.1 Layout of Equipment	4B
	4.1.1 Unit Identification	4B
	4.2 Controls	4B
	4.2.1 Rectifier and Control Unit (L.H.)	4B
	4.2.2 Rectifier and Control Unit (R.H.)	4B
	4.2.3 Radio Frequency Unit (L.H.)	5
	4.2.4 Radio Frequency Unit (R.H.)	6
	4.3 Preset and Miscellaneous Controls	6
	4.3.1 Rectifier and Control Unit (L.H.)	6
	4.3.2 Rectifier and Control Unit (R.H.)	6
	4.3.3 Radio Frequency Unit (L.H.)	6
	4.4 Rectifier and Control Unit (L.H.)	6
	4.4.1 Rectifier and Control Unit (R.H.)	7
	4.5 R.F. Unit	9
	4.5.1 Mixer Unit	10
	4.5.2 Amplifier Stages 4 and 5	11
	4.5.3 Amplifier Stage 6	12
	4.5.4 Amplifier Stage 7	13

CONTENTS (Contd.)

		Page
4.6	Mechanical Drives	14
4.6.1	R.F. Unit (L.H.) RANGE Control	14
4.6.2	FEEDER TUNE Control	14
4.6.3	STAGE 6 COUPLING Control	14A
4.6.4	STAGE 6 TUNE	14A
4.6.5	STAGE 5 NEUTRALIZING	14A
4.6.6	STAGE 7 INPUT TUNE CONTROL	14A
4.6.7	STAGE 7 & OUTPUT RANGE switch	14A
4.6.8	STAGE 7 ANODE TUNE Control	14A
4.6.9	STAGE 7 FEEDER COUPLING Control	14A
4.6.10	STAGE 7 FEEDER TUNE Control	14A
4.7	Air Cooling	14A
5	CIRCUIT DESCRIPTION GENERAL	14B
5.1	Radio Frequency Circuits (HS71 only. For HS71A see Supp.3, Sections 1 and 2)	14B
5.2	Monitoring	15
5.3	Power Supplies	15
6	CIRCUIT DESCRIPTION DETAILED	15
6.1	Rectifier and Control Unit	15
6.1.1	Filament Supplies	16
6.1.2	Bias Supply	17
6.1.3	Auxiliary H.T. Supply	17
6.1.4	Main H.T. Supply	17
6.2	R.F. Unit	18
6.2.1	General	18
6.2.2	Harmonic General	18
6.2.3	Mixer Stage	19
6.2.4	Stages 1, 2 and 3	19
6.2.5	Monitor Frequency Changer (HS71 only) (For HS71A see Supp.3)	20
6.2.6	Stages 4 and 5	20
6.2.7	STAGE 6	21
6.2.8	STAGE 6 Output Circuit	22
6.2.9	STAGE 7	22
6.2.10	The Output Circuit	22
6.2.11	Monitoring Stage 7	23
6.2.12	Feeder Indication	23

CONTENTS (Contd.)

	Page
6.3 Control Circuits	23
6.3.1 Switching-on Sequence	23
6.3.2 H.T. OFF	24
6.3.3 Overload Circuits	24
6.3.4 Trip Reset	25
6.3.5 Remote Control	25
6.3.6 Frequency Selector Control Circuit	25
6.3.7 Switching off	26
7 INSTALLATION	26
7.1 General	26
7.2 Packing, Transport and Delivery	26
7.3 Assembling the Transmitter	26A
7.4 Installing the Valves	26B
7.4.1 Fitting the BR191 Valve (Stages 6 and 7)	26B
8 SETTING UP	27
8.1 Preliminary	27
8.2 Checking Relay and Contactor Operation	27
8.3 Checking Filament Supplies	29
8.3.1 Stage 7 Filament	29
8.3.2 Stages 5, 6 and Rectifier Filaments	29
8.3.3 Auxiliary Filaments	30
8.4 Checking Bias and Auxiliary H.T. Supplies	30
8.5 Checking the Main H.T. Rectifier Output	31
8.6 Adjusting the Bias Voltages	31
8.7 Setting up the Overload Relays	32
8.7.1 Method 1	32
8.7.2 Method 2	32
8.8 Remote Control	33

CONTENTS (Contd.)

		Page
9	TUNING	34
	9.1 I.S.B. Operation	34
	9.1.1 Calculation of Harmonic Generator and Crystal Drive Frequency	34
	9.1.2 Tuning the Harmonic Generator	34
	9.1.3 Tuning the Mixer and Stages 1, 2 and 3	35
	9.1.3A Setting up the DRIVE LEVEL control	35
	9.1.4 Tuning Stage 4	35
	9.1.5 Tuning Stage 5	35
	9.1.6 Tuning Stage 6	36
	9.1.7 Tuning Stage 7	36
	9.1.8 Final Tuning	36
	9.1.9 Checking Distortion	37
	9.1.10 Setting up Mixer Preset Level Controls	37
	9.1.11 Neutralizing Stage 5	38
	9.2 C.W. and F.S.K. Operation	38
	9.2A D.S.B. Operation	38A
	9.3 Tuning when using External Drive	38A
	9.3.1 General	38A
	9.3.2 Tuning Stage 4	38A
	9.3.3 Tuning Stage 5	38A
	9.3.4 Tuning Stage 6	39
	9.3.5 Tuning Stage 7	39
	9.3.6 Final Tuning	40
10	OPERATING INSTRUCTIONS	40
	10.1 Starting up Instructions	40
	10.2 Overload Reset	41
	10.3 Closing Down Instructions	41
11	MAINTENANCE	42
	11.1 Routine Maintenance	42
	11.1.1 Daily, when the Set is in use	42
	11.1.2 Weekly	42
	11.1.3 Quarterly	43A
	11.1.4 Yearly	43A

CONTENTS (Contd.)

	Page
11.2 Stages 5, 6 and 7 Coil Tuning Contacts	43B
11.3 Alignment of the Mixer Unit	43B
11.3.1 Preliminary Alignment of the Harmonic Generator	44
11.3.2 Preliminary Alignment of the Mixer and Stages 1, 2 and 3	46
11.3.3 Balancing the Mixer Stage	48
11.3.4 Setting up the Monitor Frequency Changer ...	49
11.3.5 Final Alignment of the Mixer Unit	49
11.4 Setting up the Manual Drive Assemblies	50
11.5 Setting up the Manual Drives	52
11.6 Fuse List	52
11.7 Air Filters	53
11.8 Removal of Front Panels	53
11.9 Air Interlock Switch Setting	54
11.10 Replacement Coil Contacts	54
11.11 Back-Fire Indicators	54
11.12 Use of ACT70 Valves	54
 Abridged Valve Data	 56

COMPONENT IDENTITIES

For identities of components in the HS71 series of transmitters, refer to AP.116E-0232-3A, B and C.

CONTENTS (Contd.)

Illustrations

	Photo/Drawing No.	Fig. No.
HS71/HS71A Transmitters	41842	Frontispiece
HS71/1 Transmitter	59661	Frontispiece
<u>Operational Diagrams</u>		
Block Diagrams		
HS71/1 & HS71 Transmitters	WZ.15035/D Sh.1	1
HS71A Transmitter	WZ.18270/D Sh.1	1A
Calibration Curves		
Part 1 (HS71 & HS71/1)	WZ.15043/D Sh.1	2
Part 1 (HS71A)	WZ.18276/D Sh.1	2A
Part 2 (HS71)	WZ.15043/D Sh.2	3
Part 2 (HS71A)	WZ.18276/D Sh.2	3A
Part 2 (HS71/1)	WZ.28345/D Sh.2	3B
Part 3 (HS71)	WZ.15043/D Sh.3	4
Part 3 (HS71A)	WZ.18276/D Sh.3	4A
Part 3 (HS71/1)	WZ.28345/D Sh.3	4B
Typical Power Figures		
HS71/1	WZ.28248/D Sh.1	
	(Part)	4C
HS71	WZ.15044/D Sh.1	5
HS71A	WZ.18277/D Sh.1	5A
Control Layouts		
HS71	WZ.18301/D Sh.1)	
HS71A	WZ.18534/D Sh.1)	6
HS71/1	WZ.28348/D Sh.1	6A
<u>Component Layouts</u>		
Rectifier and Control Unit		
Part 1 (HS71 & HS71/1)	WZ.28242/D Sh.1	7
Part 1 (HS71A)		
Part 2 (HS71)	WZ.15037/D Sh.2	8
Part 2 (HS71A)		
Part 2 (HS71/1)	WZ.28242/D Sh.2	8A
Radio Frequency Unit		
Part 1 (HS71)	WZ.15040/D Sh.1)	
Part 1 (HS71A)	WZ.18275/D Sh.1)	9
Part 1 (HS71/1)	WZ.28245/D Sh.1	9A
Part 2 (HS71)	WZ.15040/D Sh.2)	
Part 2 (HS71A)	WZ.18275/D Sh.2)	10
Part 2 (HS71/1)	WZ.28245/D Sh.2	10A
Part 3 (HS71)	WZ.15040/D Sh.3)	
Part 3 (HS71A)	WZ.18275/D Sh.3)	11
Part 3 (HS71/1)	WZ.28245/D Sh.3	11A

CONTENTS (Cont.)

Fig. No

Component Layouts (Contd.)

Radio Frequency Unit (Contd.)

Part 4 (HS71)	WZ.15040/D Sh.4)	12
Part 4 (HS71A)	WZ.18275/D Sh.4)	
Part 4 (HS71/1)	WZ.28245/D Sh.4	12A
Part 5 (HS71/1)	WZ.28245/D Sh.5	12B

Mixer Unit

HS71	WZ.15042/D Sh.1	13
HS71A	WZ.24357/D Sh.1	13A
HS71/1	WZ.28247/D Sh.1	13B

Circuit Diagrams and Component Layouts

Peak Voltmeter Unit (W.38793 Ed.A)	WZ.12770/B Sh.1	14
Peak Voltmeter Unit (W.38793 Ed.D)	WZ.12771/B Sh.1	15
Coupler Assembly Type 2865P (See Supp.2, Fig.1)		

Circuit Diagram

Radio Frequency Unit

Part 1 (HS71)	WZ.15039/D Sh.1	16
Part 1 (HS71A)	WZ.18274/D Sh.1	16A
Part 1 (HS71/1)	WZ.28244/D Sh.1	16B
Part 2 (HS71)	WZ.15039/D Sh.2	17
Part 2 (HS71A)	WZ.18274/D Sh.2	17A
Part 2 (HS71/1)	WZ.28244/D Sh.2	17B
Part 3 (HS71/1)	WZ.28244/D Sh.3	17C

Mixer Unit

Part 1 (HS71 & HS71/1)	WZ.15041/D Sh.1)	18
Part 1 (HS71A)	WZ.24356/D Sh.1)	
Part 2 (HS71)	WZ.15041/D Sh.2	19
Part 2 (HS71A)	WZ.24356/D Sh.2	19A
Part 2 (HS71/1)	WZ.28246/D Sh.2	19B

Rectifier and Control Unit

Part 1 (HS71)	WZ.15036/D Sh.1	20
Part 1 (HS71A)	WZ.18271/D Sh.1	20A
Part 1 (HS71/1)	WZ.28241/D Sh.1	20B

Mod. A.4744 (Contactor replacement)

Part 2 (HS71)	WZ.15036/B Sh.2)	20C
Part 2 (HS71A)	WZ.18271/B Sh.2)	21
Part 2 (HS71/1)	WZ.28241/D Sh.2	21A

Connection Diagrams, Inter-Unit

HS71	WZ.15038/D Sh.1)	22
HS71A	WZ.18273/D Sh.1)	
HS71/1	WZ.28243/D Sh.1	22A

CONTENTS (Cont.)

Fig. No

Miscellaneous

Control Circuit Diagram		
HS71	WZ.16491/D Sh.1)	23
HS71A	WZ.18278/B Sh.1)	
HS71/1	WZ.28346/D Sh.1	23A
Interlock Switches Location		
HS71/1	WZ.28349/D Sh.1	23B
Feeder Arc Suppression and Stages 6 & 7 Grid Trip Circuit		
HS71/1	WZ.28347/D Sh.1	23C
Mechanical Drive Assemblies		
Part 1 (HS71, HS71A, HS71/1)	WZ.16492/D Sh.1	24
Part 2 (HS71, HS71A, HS71/1)	WZ.16493/D Sh.1	25

Supplements

Supplement 1	50Ω Output Impedance
Supplement 2	Feeder Monitoring Equipment for HS71
Supplement 3	HS71 and HS71A Information
Supplement 4	HS71/1 Information

Special Abbreviations

I.S.B.	Independent Sideband	HG	Harmonic Generator or Frequency Multiplier
D.S.B.	Double Sideband		
C.W.	Continuous Wave Telegraphy	V	Volt
P.E.P.	Peak Envelope Power	A or amp	Ampere
P.S.P.	Peak Signal Power	Ω	Ohm
F.S.K.	Frequency Shift Keying	W	Watt
R.F.	Radio Frequency	m	Milli (0.001)
Fils	Filaments	k	Kilo (1000)
fHG Mc/s	The frequency output of or the Harmonic Generator	M	Mega (1,000,000)
fRAD Mc/s	The radiated frequency	dB	Decibel
or		A.C.	Alternating Current
fRAD		D.C.	Direct Current
		St.	Stage

LIST 1

**Fundamental differences between Marconi HS.71 series transmitters
in use with the R. A. F.**

A.M. Ref. No.	RAF Type No.	Marconi Type	Marconi Identity	Remarks
10D/20487 971-2011 (5820-92)	T15086	HS71	W50659 Ed.A modified to WQ13379 Ed.A	Original HS71 transmitter, modified to incorporate additional fan in Rectifier and Control Unit. Output: 600 ohms. Coverage: 4-27/5 Mc/s.
10D/20468 733-2173	T10197	HS71	WQ12937 Ed.A modified to WQ13397 Ed.A	Similar to 10D/20487, but with 50 ohm output.
10D/22730 222-2177	T10197A	HS71	WQ12937 Ed.B	Same transmitter as 10D/20468, but derived from different units during manufacture. Incorporates RMC Modifications No.5661 (remote monitoring of feeder conditions) and No.6272 (improved protection of individual valves).
10D/22765 933-2165	T10197B	HS71A	WQ12940 Ed.A	Same as 10D/20487, but covers 2.5 to 20 Mc/s. Incorporates RMC Modification No.6273 (improved protection of individual valves).
10D/23679 922-2111	T15086A	HS71/1	W53269 Ed.B	Improved version of 10D/20487, but 50 ohm output.

LIST 2

List of Units

This list supplements List 1 by showing how the differences between the various transmitters affect the unit identities.

Transmitter Identity	Marconi Unit Type Nos.						
	Rectifier and Control Unit		RF Unit		Mixer Unit	4th & 5th R.F. Amp.	Output Unit
	LH	RH	LH	RH			
10D/20487 T15086	3928B	3929A	3930A	3931A	3932C	3933C	3976A
10D/20468 T10197	"	"	"	3931B	"	"	"
10D/22730 T10197A	"	"	"	"	"	"	"
10D/22765 T10197B	"	3929B	3930C	3931C	5640B	3933E	3976B
10D/23679 T15086A	3928D	3929M	3930K	3931E	3932D	3933G	3976E

3930A

UNIT COMPOSITION OF EQUIPMENTS

TRANSMITTER NATO IDENTIFICATION	933-2173	5820-99-					⑤		
		③ 933-2177	④ 933-2165	222-3343	933-2166	955-0257	933-2201	195-4853	
Control Tx. ^{LH Cabinet} 5820-99-971-2016 ✓	✓	✓	✓	✓	✓	✓	-	-	W.53271 Ed.B
Control Tx. LH Cabinet 933-2202	-	-	-	-	-	✓	✓		WR 14965/B Ed.
Control, Power Supply RH Cabt 933-2163 ✓	✓	✓	✓	✓	✓	✓	-	-	W.53271 Ed.A
Control, Power Supply RH Cabinet 933-2203	-	-	-	-	-	✓	✓		WQ.14966/B Ed.
Power Supply Aux HT 971-7078 ✓	✓	✓	✓	✓	✓	✓	-	-	W.38477 Ed.A
Power Supply Bins Rect 933-2178 ✓	✓	✓	✓	✓	✓	✓	-	-	W.37958 Ed.A
Power Supply Aux HT 933-2195 2915	-	-	-	-	-	✓	✓		W.37718 Ed.C
Power Supply Bins Rect 933-2171	-	-	-	-	-	✓	✓		WQ.14966/B Ed.
R.F. Unit ^{R.H. CABINET} 5950-99-933-2224	✓	-	-	-	-	-	-	-	W.53277 Ed.A
R.F. Unit R.H. Cabinet 933-2205	-	-	-	-	-	✓	-		WR.14967/B
R.F. Unit R.H. Cabinet 933-2176	-	-	-	✓	-	-	-		W.53277 Ed.A
R.F. Unit R.H. Cabinet 933-2917	-	✓	✓	-	-	-	-		W.53277 Ed.A
R.F. Unit L.H. Cabinet 933-2175	-	-	-	✓	✓	-	-		W.53274 Ed.A
R.F. Unit L.H. Cabinet 933-2159	-	✓	✓	-	-	-	-		W.53274 Ed.A
R.F. Unit L.H. Cabinet 933-2204	-	-	-	-	-	✓	✓		WR.14968/B Ed.
R.F. Unit LH 5820-99-956-1465 ✓	✓	-	-	-	-	-	-		W.53274 Ed.A
R.F. Unit 955-0258	-	-	-	-	✓	-	-		WR.15326/B Ed.
R.F. Unit 195-4854	-	-	-	-	-	-	✓		WQ.15577/B Ed.
Mixer Stage Frequency 933-2185 ✓	✓	-	-	-	-	-	-		W.37920 Ed.
Mixer Stage Frequency 933-2161	-	✓	-	-	-	-	-		W.37920 Ed.
Mixer Stage Frequency 933-2206	-	-	-	-	-	✓	✓		WR.14969/B Ed.
Mixer Stage Frequency 971-2015	-	-	-	✓	✓	-	-		SNB 789 W.37920 Ed.
Mixer Stage Frequency 222-3832	-	-	✓	-	-	-	-		W.37920 Ed.C
Amplifier, R.F. ^{4th & 5th} 971-2018 ✓	✓	-	-	✓	✓	-	-		SNB W.3908 Ed.
Amplifier, R.F. -- 933-2207	-	-	-	-	-	✓	✓		WQ.14958/B Ed.
Amplifier, R.F. -- 933-2162	-	✓	✓	-	-	-	-		W.3908 Ed.

A.P.116E-0232-1 R.H. 933-2160 ✓
A.L.10 Sep '71 R.F. Cabinet

Tx. 21, 22 and 23 are this type.

HS.71 WQ.12937 Ed. Tx 4
HS.71 WQ.12937 Ed.B
HS.71 WQ.12940 Ed.A
HS.71 WQ.12940 Ed.A
HS.71 W.53269 Ed.A
HS.71 WQ.15325/B Ed.A
HS.71/W W.53269 Ed.B
HS.71/W W.15577/B Ed.A

9
51 540 535
158 314 214 215
Tx. 21
Tx. 22
Tx. 23
Type SA/4
Type S3/1
Tx. 21
Tx. 22
Tx. 23
Tx. 21
Tx. 22
Tx. 23
Tx. 21
Tx. 22
Tx. 23
Tx. 21
Tx. 22
Tx. 23
Tx. 21
Tx. 22
Tx. 23

MODIFICATION STATE OF THE EQUIPMENT

Modification Record Labels are fitted to the units of the equipment listed below. Embodiment of a modification is indicated by scoring through the relevant number on the appropriate label.

The amendment state of this manual is related to the modification state of the equipment. To ensure that this relationship may be determined at any time, the following table is re-issued with successive amendments to the manual.

Unit No.	Unit or Sub-Unit Title	Modification State of Unit or Sub-Unit Related to Amendment State of Manual											
		2	2										
A	Control, Transmitter 10K/5820-99-2016	2	2										
B	Control Transmitter 10L/5820-99-933-2202	3	3										
C	Control, Power Supply Type S30/1 10L/5820-99-933-2163	6	9										
D	Control, Power Supply Type S30/2 10L/5820-99-933-2203	5	8										
E	Power Supply 10K/5820-99-971-7078	1	1										
F	Power Supply Type S62/1 10K/5820-99-933-2178	3	3										
G	Power Supply Type S62/2 10K/5820-99-933-2171	3	3										
H	Power Supply Type S65/1 10K/5820-99-933-2915	1	1										
J	Radio Frequency Unit Type S3/1 10D/5820-99-933-2175	7	7										
K	Radio Frequency Unit Type S3/2 10D/5820-99-933-2159	6	6										
L	Radio Frequency Unit Type S3/3 10D/5820-99-933-2204	3	3										
M	Radio Frequency Unit Type S4/2 10D/5820-99-933-2224	8	8										
N	Radio Frequency Unit Type S4/3 10D/5820-99-933-2205	4	4										
Amendment State of Manual		10	12										

MODIFICATION STATE (Continued)

Unit No.	Unit or Sub-Unit Title	Modification State of Unit or Sub-Unit Related to Amendment State of Manual											
P	Radio Frequency Unit Type S4/4 10D/5820-99-933-2176	10	10										
Q	Radio Frequency Unit Type S4/5 1CD/5820-99-933-2917	8	8										
R	Radio Frequency Unit 10D/5820-99-195-4854	0	0										
S	Radio Frequency Unit 10D/5820-99-965-1465	7	7										
T	Mixer Stage Frequency Type S4/1 1CD/5820-99-933-2185	3	3										
U	Mixer Stage Frequency Type S4/4 10D/5820-99-933-2161	2	2										
V	Mixer Stage Frequency Type S4/6 1CD/5820-99-933-2206	2	2										
W	Mixer Stage Frequency 1CD/5820-99-971-2015	2	2										
X	Mixer Stage Frequency 10D/5820-99-222-3832	0	0										
Y	Amplifier, R.F. 1CD/5820-99-971-2018	4	4										
Z	Amplifier, R.F. 37/2 1CD/5820-99-933-2207	2	2										
AA	Amplifier, R.F. 37/4 10D/5820-99-933-2162	4	4										
	Amendment State of Manual	10	12										

MODIFICATION SUMMARY

CONTROL, TRANSMITTER

5820-99-971-2016

A Summary of modifications to the above is given below. This summary is provided for information only, and does NOT constitute an authority to demand modification kits where the equipment held has not been modified.

Mod. Strike-off	Summary of Modification	Reason
1	Mods. 7494, 9102, 9103 or 9105. Addition of NATO Identification and Modification Record labels.	To record Reference Identities and Mod. Strike-offs.
2	Mod. 9784. Introduction of variable bias resistors and back-fire indicators for the CV2518 valves	To reduce maintenance time

MODIFICATION SUMMARY

CONTROL TRANSMITTER

5820-99-933-2202

A Summary of modifications to the above is given below. This summary is provided for information only, and does NOT constitute an authority to demand modification kits where the equipment held has not been modified.

Mod. Strike-off	Summary of Modification	Reason
1	Mod. No. 9104 adds Identification and Modification Record labels.	To record Reference Identities and Mod. Strike-offs.
2	Mod. No. 9784 introduces variable bias resistors and back-fire indicators for the CV2518 valves.	To reduce maintenance time.
3	Mod. No. 1997 incorporates additional audio alarm facilities.	To reduce transmitter outage time.

MODIFICATION SUMMARY

CONTROL POWER SUPPLY

TYPE S30/1

5820-99-933-2163

A Summary of modifications to the above is given below. This summary is provided for information only, and does NOT constitute an authority to demand modification kits where the equipment held has not been modified.

Mod. Strike-off	Summary of Modification	Reason
1	Mod. 6273. Removal of h.t. overload relays.	To improve individual valve protection.
2	Mod. 6616. General circuit improvements.	To improve performance.
3	Mods. 7494, 9102, 9103 or 9105. Addition of NATO Identification and Modification Record Labels.	To record Reference Identities and Mod. Strike-offs.
4	Mod. 8628. Modifications to enable BR.191 and BR.191B valves to be replaced by CV8730 valves.	To improve performance.
5	Mod. 0108. Repositioning of metal rectifier MRL.	To facilitate servicing
6	Mod. 9784. Introduction of variable bias resistors and back-fire indicators.	To reduce maintenance time.
7	-	
8	Mod. A.3977. Fitting, on failure, of a replacement type fan assembly having ball bearings and access for external lubrication.	Bearing seizure has caused burn out of fan assembly used for air cooling of control power supply cabinet.
9	Mod. A.4744. Replacement contactor.	Old type unobtainable.

MODIFICATION SUMMARY

CONTROL POWER SUPPLY

TYPE S30/2

5820-99-933-2203

A Summary of modifications to the above is given below. This summary is provided for information only, and does NOT constitute an authority to demand modification kits where the equipment held has not been modified.

Mod. Strike-off	Summary of Modification	Reason
1	Mod. 6616. General circuit improvements.	To improve performance.
2	Mod. 9104. Addition of NATO Identification and Modification Record labels.	To record Reference Identities and Mod. Strike-offs.
3	Mod. 0108. Repositioning of metal rectifier MRL.	To facilitate servicing.
4	Mod. 9784. Introduction of variable bias resistors and back-fire indicators.	To reduce maintenance time.
5	Mod. 0587. Transfer meters to forward-sloping meter panels.	To facilitate ease of observation when tuning.
6	-	
7	Mod. A.3977. Fitting, on failure, of a replacement type fan assembly having ball bearings and access for external lubrication.	Bearing seizure has caused burn out of motor of fan assembly used for air cooling of control power supply circuit.
8	Mod. A. 4744. Replacement contactor.	Old type unobtainable.

MODIFICATION SUMMARY

AMPLIFIER, RADIO FREQUENCY TYPE S37/2

5820-99-933-2207

A Summary of modifications to the above is given below. This summary is provided for information only, and does NOT constitute an authority to demand modification kits where the equipment held has not been modified.

Mod. Strike-off	Summary of Modification	Reason
1	Mod. 6616. General circuit improvements.	Improvement in performance.
2	Mod. 9104. Addition of NATO Identification and Modification labels.	To record Reference Identities and Mod. Strike-offs.

MODIFICATION SUMMARY

POWER SUPPLY

5820-99-971-7078

A Summary of modifications to the above is given below. This summary is provided for information only, and does NOT constitute an authority to demand modification kits where the equipment held has not been modified.

Mod. Strike-off	Summary of Modification	Reason
1	Mod. 7494, 9102, 9103 or 9105. Addition of NATO Identification and Modification Record labels.	To record Reference Identities and Mod. Strike-offs.

MODIFICATION SUMMARY

POWER SUPPLY TYPE S62/1

5820-99-933-2178

A Summary of modifications to the above is given below. This summary is provided for information only, and does NOT constitute an authority to demand modification kits where the equipment held has not been modified.

Mod. Strike-off	Summary of Modification	Reason
1	Mod. 6616. General circuit improvements.	Improvement in performance.
2	Mods. 7494, 9102, 9103 or 9105. Addition of NATO Identification and Modification Record labels.	To record Reference Identities and Mod. Strike-offs.
3	Mod. 9784. Introduction of variable bias resistors and back-fire indicators.	To reduce maintenance time.

MODIFICATION SUMMARY

POWER SUPPLY TYPE S62/2

5820-99-933-2171

A Summary of modifications to the above is given below. This summary is provided for information only, and does NOT constitute an authority to demand modification kits where the equipment held has not been modified.

Mod. Strike-off	Summary of Modification	Reason
1	Mod. 6616. General circuit improvements.	To improve performance.
2	Mod. 9104. Addition of NATO Identification and Modification Record labels.	To record Reference Identities and Mod. Strike-offs.
3	Mod. 9784. Introduction of variable bias resistors and back-fire indicators.	To reduce maintenance time.

MODIFICATION SUMMARY

POWER SUPPLY TYPE S65/1

5820-99-933-2915

A Summary of modifications to the above is given below. This summary is provided for information only, and does NOT constitute an authority to demand modification kits where the equipment held has not been modified.

Mod. Strike-off	Summary of Modification	Reason
1	Mod. 9104. Addition of NATO Identification and Modification Record labels	To record Reference Identities and Mod. Strike-offs.

MODIFICATION SUMMARY

RADIO FREQUENCY UNIT TYPE S3/1

5820-99-933-2175

A Summary of modifications to the above is given below. This summary is provided for information only, and does NOT constitute an authority to demand modification kits where the equipment held has not been modified.

Mod. Strike-off	Summary of Modification	Reason
1	Mod. 6564. Various mods. to front panels, air filter, flexible ducting and fan.	To provide greater protection against over-heating and dust infiltration.
2	Mod. 6616. General circuit improvements.	To improve performance.
3	Mod. 6756. Transfers meters to forward sloping meter panel	To facilitate ease of observation during tuning.
4	Mod. 9102 or 9105. Addition of NATO Identification and Modification Record labels.	To record Reference Identities and Mod. Strike-offs.
5	Mod. 8628. BR.191 valves replaced by ACT.70 valves.	Improvement in performance.
6	Mod. 8283. Fits new spring contacts and larger diameter drive wheel to stages 6 and 7 tuning coils.	To eliminate burning of contacts.
7	Mod. 8284. Introduced more positive fixing for end stops and face plates of tuning controls.	To prevent sparking and deterioration of tuning coils due to overriding.

MODIFICATION SUMMARY

RADIO FREQUENCY UNIT TYPE S3/2

5820-99-933-2159

A Summary of modifications to the above is given below. This summary is provided for information only, and does NOT constitute an authority to demand modification kits where the equipment held has not been modified.

Mod. Strike-off	Summary of Modification	Reason
1	Mod. 6564. Various mods. to front panels, air filter, flexible ducting and fan.	To provide greater protection against over-heating and dust infiltration.
2	Mod. 6616. General circuit improvements.	To improve performance.
3	Mod. 6756. Transfers meters to forward sloping meter panel.	To facilitate ease of observation during tuning.
4	Mod. 9103. Addition of NATO Identification and Modification Record labels.	To record Reference Identities and Mod. Strike-offs.
5	Mod. 8628. BR.191 valves replaced by ACT.70 valves.	Improvement in performance.
6	Mod. 8283. Fits new spring contacts and larger diameter drive wheel to stages 6 and 7 tuning coils.	To eliminate burning of contacts.

MODIFICATION SUMMARY

RADIO FREQUENCY UNIT TYPE S3/3

5820-99-933-2204

A Summary of modifications to the above is given below. This summary is provided for information only, and does NOT constitute an authority to demand modification kits where the equipment held has not been modified.

Mod. Strike-off	Summary of Modification	Reason
1	Mod. 6616. General circuit improvements.	To improve performance.
2	Mod. 9104. Addition of NATO Identification and Modification Record labels.	To record Reference Identities and Mod. Strike-offs.
3	Mod. 0587. Transfers meters to forward sloping meter panels.	To facilitate ease of observation when tuning.

MODIFICATION SUMMARY

RADIO FREQUENCY UNIT TYPE 4/2

5820-99-933-2224

A Summary of modifications to the above is given below. This summary is provided for information only, and does NOT constitute an authority to demand modification kits where the equipment held has not been modified.

Mod. Strike-off	Summary of Modification	Reason
1	Mod. 5359. Provides additional r.f. output.	To operate frequency measuring equipment in control console.
2	Mod. 6564. Various mods. to front panels, air filter, flexible ducting and fan.	To provide greater protection against overheating and dust infiltration.
3	Mod. 6616. General circuit improvements.	Improvement in performance.
4	Mod. 6756. Transfers meters to forward sloping panels.	To facilitate observation while tuning.
5	Mod. 9102. Addition of NATO Identification and Modification Record labels.	To record Reference Identities and Mod. Strike-offs.
6	Mod. 8628. BR.191B valves replaced by ACT.70 valves.	Improvement in performance.
7	Mod. 8283. Fits new spring contacts and larger diameter drive wheel to stages 6 and 7 tuning coils.	To eliminate burning of contacts.
8	Mod. 8284. Introduced more positive fixing for end stops and face plates of tuning controls.	To prevent sparking and deterioration of tuning coils due to overriding.

MODIFICATION SUMMARY

RADIO FREQUENCY UNIT TYPE S4/3

5820-99-933-2205

A Summary of modifications to the above is given below. This summary is provided for information only, and does NOT constitute an authority to demand modification kits where the equipment held has not been modified.

Mod. Strike-off	Summary of Modification	Reason
1	Mod. 6616. General circuit improvements.	Improvement in performance.
2	Mod. 9104. Addition of NATO Identification and Modification Record labels.	To record Reference Identities and Mod. Strike-offs.
3	Mod. 9141. Provision of additional r.f. output.	To operate frequency measuring equipment in control console.
4	Mod. 0587. Transfers meters to forward sloping panels.	To facilitate observation during tuning.
-	Mod. 0496. Converts this unit into R.F. Unit 5820-99-195-4854.	

MODIFICATION SUMMARY

RADIO FREQUENCY UNIT TYPE S4/4

5820-99-933-2176

A Summary of modifications to the above is given below. This summary is provided for information only, and does NOT constitute an authority to demand modification kits where the equipment held has not been modified.

Mod. Strike-off	Summary of Modification	Reason
1	Mod. 6564. Various mods. to front panels, air filter, flexible ducting and fan.	To provide greater protection against overheating and dust infiltration.
2	Mod. 6616. General circuit improvements.	To improve performance.
3	Mod. 6756. Transfers meters to forward sloping meter panels.	To facilitate observation during tuning.
4	Mod. 7311. Rearranged connection between tops of V6 and V7.	To obviate possibility of flashovers.
5	Mod. 9105. Addition of NATO Identification and Modification Record labels.	To record Reference Identities and Mod. Strike-offs.
6	Mod. 8628. BR.191B valves replaced by ACT.70 valves.	Improvement in performance.
7	Mod. 8283. Fits new spring contacts and larger diameter driving wheel to stages 6 and 7 tuning coils.	To eliminate burning of contacts.
8	Mod. 8284. Introduced more positive fixing for end stops and face plates of tuning coils.	To prevent sparking and deterioration of tuning coils due to overriding.
9	-	-
10	Mod. 9143. Provision of additional r.f. output.	To operate frequency measuring equipment in control console.

MODIFICATION SUMMARY

RADIO FREQUENCY UNIT TYPE S4/5

5820-99-933-2917

A Summary of modifications to the above is given below. This summary is provided for information only, and does NOT constitute an authority to demand modification kits where the equipment held has not been modified.

Mod. Strike-off	Summary of Modification	Reason
1	Mod. 6564. Various mods. to front panels, air filter, flexible ducting and fan.	To provide greater protection against overheating and dust infiltration.
2	Mod. 6616. General circuit improvements.	Improvement in performance.
3	Mod. 6756. Transfers meters to forward sloping panels.	To facilitate observation while tuning.
4	Mod. 7311. Rearranged connections between tops of valves V6 and V7.	To obviate possibility of flashovers.
5	Mod. 9103. Addition of NATO Identification and Modification Record labels.	To record Reference Identities and Mod. Strike-offs.
6	Mod. 8628. BR.191B valves replaced by ACT.70s.	Improvement in performance.
7	Mod. 8283. New spring contacts and drive wheel fitted to stages 6 and 7 tuning coils.	To eliminate burning of contacts.
8	Mod. 9142. Provision of additional r.f. output.	To operate frequency measuring equipment in control console.

MODIFICATION SUMMARY

RADIO FREQUENCY UNIT

5820-99-956-1465

A Summary of modifications to the above is given below. This summary is provided for information only, and does NOT constitute an authority to demand modification kits where the equipment held has not been modified.

Mod. Strike-off	Summary of Modification	Reason
1	Mod. 6564. Various mods. to front panels, air filter, flexible ducting and fan.	To provide greater protection against overheating and dust infiltration.
2	Mod. 6616. General circuit improvements.	Improvement in performance.
3	Mod. 6756. Transfers meters to forward sloping panels.	To facilitate observation during tuning.
4	Mod. 7494. Addition of NATO Identification and Modification Record labels.	To record Reference Identities and Mod. Strike-offs.
5	Mod. 8628. BR.191B valves replaced by ACT.70s.	Improvement in performance.
6	Mod. 8283. New spring contacts and drive wheel fitted to stages 6 and 7 coils.	To eliminate burning of contacts.
7	Mod. 8284. Provision of additional r.f. output	To operate frequency measuring equipment in control console.

MODIFICATION SUMMARY

MIXER STAGE FREQUENCY TYPE S4/1
5820-99-933-2185

A Summary of modifications to the above is given below. This summary is provided for information only, and does NOT constitute an authority to demand modification kits where the equipment held has not been modified.

Mod. Strike-off	Summary of Modification	Reason
1	Mod. 6616. General circuit improvements.	Improvement in performance.
2	Mod. 7494. Addition of NATO Identification and Modification labels.	To record Reference Identities and Mod. Strike-offs.
3	Mod. 0588. Provision of R.F. Filters in Mixer Unit power leads	Improvement in performance.

MODIFICATION SUMMARY

MIXER STAGE FREQUENCY TYPE S4/4

5820-99-933-2161

A Summary of modifications to the above is given below. This summary is provided for information only, and does NOT constitute an authority to demand modification kits where the equipment held has not been modified.

Mod. Strike-off	Summary of Modification	Reason
1	Mod. 6616. General Circuit improvements.	Improvement in performance.
2	Mod. 9103. Addition of NATO Identification and Modification labels.	To record Reference Identities and Mod. Strike-offs.

MODIFICATION SUMMARY

MIXER STAGE FREQUENCY TYPE S4/6

5820-99-933-2206

A Summary of modifications to the above is given below. This summary is provided for information only, and does NOT constitute an authority to demand modification kits where the equipment held has not been modified.

Mod. Strike-off	Summary of Modification	Reason
1	Mod. 6616. General circuit improvements.	Improvement in performance.
2	Mod. 9104. Addition of NATO Identification and Modification labels.	To record Reference Identities and Mod. Strike-offs.

MODIFICATION SUMMARY

MIXER STAGE FREQUENCY

5820-99-971-2015

A Summary of modifications to the above is given below. This summary is provided for information only, and does NOT constitute an authority to demand modification kits where the equipment held has not been modified.

Mod. Strike-off	Summary of Modification	Reason
1	Mod. 6616. General circuit improvements.	Improvement in performance.
2	Mod. 9102 or 9105. Addition of NATO Identification and Modification labels.	To record Reference Identities and Mod. Strike-offs.

A.P.116E-0232-1

A.L.10 Sep '71

MODIFICATION SUMMARY

AMPLIFIER, RADIO FREQUENCY

5820-99-971-2018

A Summary of modifications to the above is given below. This summary is provided for information only, and does NOT constitute an authority to demand modification kits where the equipment held has not been modified.

Mod. Strike-off	Summary of Modification	Reason
1	Mod. 6564. Various mods. to front panels, air filter, flexible ducting and fan.	To provide greater protection against over-heating and dust infiltration
2	Mod. 6566. Circuit mods.	To enable internal and external drive levels to be set at input to stage 4 r.f. amplifier.
3	Mod. 6616. General circuit improvements.	Improvement in performance.
4	Mods. 7494, 9102 or 9105. Addition of NATO Identification and Modification labels.	To record Reference Identities and Mod. Strike-offs.

MODIFICATION SUMMARY

AMPLIFIER, RADIO FREQUENCY TYPE S37/4

5820-99-933-2162

A Summary of modifications to the above is given below. This summary is provided for information only, and does NOT constitute an authority to demand modification kits where the equipment held has not been modified.

Mod. Strike-off	Summary of Modification	Reason
1	Mod. 6564. Various mods. to front panels, air filter, flexible ducting and fan.	To provide greater protection against overheating and dust infiltration.
2	Mod. 6566. Various circuit mods.	To enable internal and external drive levels to be set at input to stage 4 r.f. amplifier.
3	Mod. 6616. General circuit improvements.	Improvement in performance.
4	Mod. 9103. Addition of NATO Identification and Modification labels.	To record Reference Identifies and Mod. Strike-offs.

9 kW H.F. I.S.B. TRANSMITTERS
TYPES HS71, HS71A
AND HS71/1

1 INTRODUCTION

This Air Publication, together with Supplements 1 to 4, covers the HS71 series of transmitters shown in List 1 inside the front cover. Minor differences between the basic HS71 transmitter and its variants are dealt with in the text of the main handbook; where the differences are large, reference is made to the appropriate supplement.

The Types HS71, HS71/1 and HS71/A transmitters are general purpose transmitters for use in the frequency range 2.5-27.5 Mc/s.

External units are used to provide the drive and service of operation. Drive frequencies are normally supplied by Type HD21 Crystal Drive Units.

For F.S.K. or F.S. Diplex services these would normally be used in conjunction with a Type HD20 F.S.K. Drive Assembly providing the necessary keying and monitoring equipment. For F.S. Diplex operation the Type HD61B Frequency Shift Diplex Equipment may also be employed. In this case the drive output is at radiated frequency and the HD21 Crystal Drive Units are not required.

For i.s.b. operation the Crystal Drives may be used with either Type HD51 or Type I.S.B. Drive Equipments.

The frequency range is covered without external change of coils etc., and the transmitter may be tuned to any of six frequencies without adjustment of the crystal oscillator equipment after the initial setting up, by using the six HD21s contained in the HD20 cabinet.

Air cooling is provided for the R.F. Cabinets by a fan mounted externally via an air duct mounted on the cabinet roof.

A comprehensive system of interlocks is provided in the transmitter to safeguard the operating personnel and to ensure correct operating procedure to prevent damage to the transmitter when either switching on or off.

The provision for remote control ON/OFF switching is no longer used but can readily be restored to its pre-modification state by reference to A.P.2922E, Vol.2.

An envelope correction circuit is fitted to minimise i.s.b. distortion by the transmitter.

2 TECHNICAL SUMMARY

2.1 SALIENT FEATURES

Types of service available

- (a) C.W. Telegraphy ON/OFF keying with optional anti-fading Frequency Modulation (A1 & F2).
- (b) Frequency Shift Telegraphy (F1).
- (c) Independent Sideband (A3b).
- (d) D.S.B. Telephony, Low Power (A3).

NOTE: *To provide services (a) and (b) the Type HD22 Keying Unit of a Type HD61B Frequency Shift Duplex Equipment is used. For services (c) and (d), the Type HD51 I.S.B. Drive or a Type SSD2 Single Sideband Generating Equipment is used.*

Power Supply * 380-440V three-phase, four wire
a.c. 50 or 60 c/s.
Voltages regulation $\pm 6\%$.
Frequency Tolerance $\pm 2.5\%$.

*

NOTE: *The Fan supplied will differ according to customer's requirements due to the input voltage and will be either for voltages between 380-420V or 400-440V.*

Power Consumption

C.W: 21 kW on Mark, at $7\frac{1}{2}$ kW output to 10 kW on Space.
F.S.K: 21 kW at $7\frac{1}{2}$ kW output.
I.S.B. 18 kW with two-tone modulation at 10 kW p.e.p.
10 kW with -26 dB carrier only.

Control additional Local Remote ON/OFF switching is no longer used.

Overall Dimensions

Height	Width	Depth
7 ft 6 in (2.28m)	10 ft 6 in (3.22m)	4 ft 4 in (1.32m)

Feeder Impedance See List 1 inside cover 2/1 maximum s.w.r.
200 Ω or 75 Ω can be provided using an external wide band transformer.

Cooling By external Fan.

2.2 PERFORMANCE

Frequency range 4 to 27.5 Mc/s (HS71 and HS71/1),
2.5-20 Mc/s (HS71A)

Power output to Feeder	<ul style="list-style-type: none"> (a) 9-10 kW p.e.p. on i.s.b. (A3b) (b) 6-7 kW on c.w. on/off telegraphy (A1 & F2) or f.s.k.(fl) (using i.s.b. loading). (c) 7-7$\frac{1}{2}$ kW on c.w. on/off telegraphy (A1 & F2 or f.s.k.(fl) (using optimum loading). (d) 5.5-$\frac{1}{4}$ kW carrier on low level d.s.b. telephony.
Non-linear Distortion	Third order intermodulation products to be not greater than -36 dB relative to either of two equal test tones, at any power level of up to full p.e.p.
Harmonic Radiation	Less than 200 mW, in accordance with Atlantic City regulations.
Transmitter Bandwidth	Level within ± 0.5 dB to 6 kc/s relative to carrier frequency.
R.F. input levels	Nominal 0.1 watt from primary drive, and 0.25 watt from i.s.b. or keyed telegraph drive at 5.1 Mc/s (HS71 and HS71/1) and 5.1 and 6.2 Mc/s or 2.1 Mc/s (HS71A)
Noise Level and Spurious Radiation	<ul style="list-style-type: none"> (a) Individual components in band 200 c/s either side of the carrier to be less than -30 dB relative to the carrier for carrier levels up to -16 dB relative to p.e.p. (b) All components of a single tone up to -6 dB relative to p.e.p. are less than -50 dB relative to p.e.p.
Pilot Carrier Compression	Less than 1 dB for any level of signal frequency signal up to -6 dB below peak sideband power.
D.S.B. Distortion	Less than 10% measured at 80% modulation depth (including 2% of D.S.B. Drive Unit).
D.S.B. Frequency response	Less than 2 $\frac{1}{2}$ dB from 200-3500 c/s measured at 60% modulation depth (including ± 2 dB of D.S.B. Drive Unit).

3 EQUIPMENT LIST

HS71 Transmitters

See List 2 at front of handbook

Table 1

VALVE LIST

Valve Type		Unit				
Commercial	Services	Rect. and Control	R.F. Stages 1-6	R.F. Stage 7	Mixer	Total
Z77	CV138				7	7
	CV717*	2				2
5B255M	CV391				2	2
5B254M	CV428		2			2
STV280/80***		1				1
N77	CV136				2	2
C1112 or QY4250	CV2131		2			2
BR191B or ACT70	- -)		1	2		3
GXU2	CV2518	6				6
VR75/40	CV3798 CV4014	1			2****	1 2
Total		10	5	2	13	30

* was CV378

** STV280/80/S in HS71/1

*** See Supp. 3, Sect. 6.1

An abridged valve data list is given in Section 11.

4 GENERAL DESCRIPTION

4.1 LAYOUT OF EQUIPMENT

The transmitters consist of four cabinets mounted side by side on a wooden plinth. The cubicles are bolted together and have an air duct fitted to the roofs of the two control cabinets. A suction fan, usually mounted in a fan room, extracts the warm air from the bottom of the r.f. cabinets via the air duct between the second and third cabinets.

Usually found on the transmitting hall wall behind the transmitter is the wall isolator which controls the power supply to the transmitter.

Connection to and from the transmitter and between cabinets is made via plugs, sockets and tagboards in the cabinet roofs.

4.1.1 Unit Identification

Layout Diagram: Fig.6 (HS71/1: Fig.6A)

The four cubicles comprise two rectifier and control units on the left and two Radio Frequency Units on the right. The cabinets will be identified throughout this handbook as the rectifier and control unit left-hand (R.C.U. L.H.) or right-hand (R.C.U. R.H.) and the Radio frequency and left-hand (R.F. Unit L.H.) or right-hand (R.F. Unit R.H.).

4.2 CONTROLS

The main controls on this transmitter are on the front panels of the various sub-units and on the top of the Mixer Unit chassis; therefore the following list has been sub-divided into front panel and chassis controls for each sub-unit.

4.2.1 Rectifier and Control Unit (L.H.)

Front

MAINS ISOLATOR switch	SWA
H.T. EARTHING switch	SWB
H.T. INTERLOCK switch	SWP

4.2.2 Rectifier and Control Unit (R.H.)

Front

Control Panel

START switch	SWC
STOP switch	SWD
H.T. ON switch	SWE
H.T. OFF & RESET switch	SWF
LOCAL/REMOTE switch	SWG (No longer used.)
FREQUENCY switch	SWL and SWM
MANUAL/AUTO switch	SWN
GRID CURRENT TRIP LEVEL control	SWR (HS71/1 only)

4B

Rheostat and Fuse Panel

A.C. VOLTMETER switch	SWH
H.T. VOLTS switch	SWJ
STAGE 5, 6 & RECT. FILS	RV2, 3 & 4
STAGE 7 FILS.	RV1

4.2.3 Radio Frequency Unit (L.H.)

Front

Top control panel

RANGE control	SWA, C & D
STAGE 5 H.T. INTERLOCK switch	SWF
STAGE 6 OUTPUT TUNE control	C64, SWM & SWP

4th & 5th R.F. Amplifier

STAGE 5 TUNE	L15
STAGE 5 NEUTRALISING	C16
STAGE 4 TUNE	C14 SWL & COIL TURRET
FEEDBACK	RV2
EXT. DRIVE LEVEL	RV7 (HS71, HS71A) RV3 (HS71/1)

Mixer Unit

Front

HG TUNE	C5, 14, 25, 41 & 47
MIXER TUNE	C55, 66, 82, 94 & 100
fHG Mc/s switch	SWA
HG METERING switch	SWB
MIXER & MONITOR METERING switch	SWD
fRAD Mc/s switch	SWC

Chassis

Title	Circuit Ref.	Function
MANUAL	RV5	Mixer level control
MANUAL/REMOTE	SWF	Mixer level control selector
BALANCE/NORMAL	SWE	Switches off Stages 2 and 3 screen supply when balancing the Mixer

Bottom Control Panel

Front

STAGE 6 COUPLING	L20
STAGE 6 OUTPUT TUNE	L19
FIL. VOLTMETER SWITCH	SWJ
AUX. VOLTMETER SWITCH	SWK

4.2.4 Radio Frequency Unit (R.H.)

Front

STAGE 7 INPUT TUNE	L30
FEEDER TUNE	C89, C90 (HS71/1: C90 only)
ST.7 & OUTPUT RANGE SWITCH	SWN & SWP (HS71/1: SWN & SWR)
STAGE 7 ANODE TUNE	L33
FEEDER COUPLING	L34
REFLECTOMETER TEST PANEL	(HS71/1 only: see Supp.4, Sect.4.2.4)

4.3 PRESET AND MISCELLANEOUS CONTROLS

4.3.1 Rectifier and Control Unit (L.H.)

Rear

Stage 6 filament supply reversing switch	SWQ
Stage 6 filament supply controls	R22, R23 & R24

4.3.2 Rectifier and Control Unit (R.H.)

Rear

Stage 5 filament supply reversing switch	SWK
Stage 5 filament supply controls	R8, R9 and R10
6.3V filament supply control	R2

4.3.3 Radio Frequency Unit (L.H.)

Mixer Unit chassis

Title	Circuit Ref.	Function
AMPLIFIER	RV4	Stage 2 bias control
RV3	RV3	Stage 3 bias control
RV1	RV1	Mixer balance control
C63	C63	Mixer balance control
1	RV6	Mixer level control, frequency A
2	RV7	Mixer level control, frequency B
3	RV8	Mixer level control, frequency C
4	RV9	Mixer level control, frequency D
5	RV10	Mixer level control, frequency E
6	RV11	Mixer level control, frequency F
STAGES 5/6 COUPLING	C35	V4/V5 coupling (HS71/1 only).

VLM

4.4 RECTIFIER AND CONTROL UNIT (L.H.)

Component Layout Fig.7.

On the front of this cubicle is mounted the Interlock Control Panel; it comprises three switches; the H.T. Interlock (SWP), H.T. Earthing (SWB) and the Mains Isolator (SWA) and eight locks and keys. Each key fits in another lock associated with the cubicle doors and are set so that when the doors are locked the key must be removed and placed in position on the control panel and again locked before the three main switches mounted above may be operated to switch the transmitter on. Thus, when the transmitter is operating the doors are locked so that operating personnel cannot obtain access without first switching off.

The keys are in two banks of four and are associated: one bank to the Mains Isolator and one bank to the H.T. Earthing and H.T. Interlock switches. This allows the Mains Isolator to be closed without the R.F. Cubicle doors being shut, thus permitting the control and filament voltages to be checked as described in Section 8.

A rear view of the cubicle is shown on the component layout with its rear door removed. Mounted on the right-hand wall is the Stage 6 filament rectifier MR8, the Stage 7 bias rectifier MR7, the Stage 7 bias smoothing capacitors C19 to C23, the Stage 7 bleeder resistors R21, the Stage 6 filament polarity reversing switch SWQ, the Stage 7 bias transformer TR16 and the Stage 6 filament transformer input resistors R22, R23 and R24.

On the left-hand wall is mounted the 3-phase input terminal board TB1, various other tagboards TB11, TB12 and TB13, and the input current transformer TR18 and its shunt resistor R25. Also mounted on the wall, in HS71/1 only, is the main circuit breaker CB1.

In the base of the cabinet on the right are the Stage 7 bias smoothing chokes L8 and L9, the Stage 6 filament 3-phase transformer TR17, and on the left, the Stage 7 filament transformer TR3 and the Main H.T. transformer TR8.

4.4.1 Rectifier and Control Unit (R.H.)

Component Layout Fig.8 (HS71/1: Fig.8A)

This is the second cabinet from the left and contains various sub-units of the power and power control circuits. A cooling fan is mounted on the cabinet roof.

The component layout shows a front panel view with the front door removed. From this it can be seen that the cabinet consists of four panels, including the meter panel, which is exposed when the door is closed.

The top panel covered by the door is the contactor and relay panel and details of the functions of the various contactors and relays are given in Table 2.

Table 2

Relay or Contactor	Function of Circuits
ILR	Interlock Pilot Relay (HS71/1 only)
SP	Reflectometer trip.
CB	Mains Overload trip (HS71/1 only)
OR	H.T. Trip Relay
ST	Start Contactor
FC	Filaments-on Contactor
FD	Time Delay Switch (filaments)
FF	Fil. and Bias Contactor
LA	Aux. H.T. Contactor
MC	Main H.T. Contactor

Below the contactor panel is the control panel which is accessible through the aperture in the door when it is closed.

The bottom panel is the Rheostat and Fuse Panel. This is made in two parts, one containing the fuses (see Table 5 Section 11.6) and the other operating controls (see Section 4.2.2). These controls, as on the control panel, are accessible when the door is closed, whereas the fuses are covered and cannot be removed until the door has been opened, i.e. when the transmitter has been switched off.

The meter panel carries three meters and four variable resistors. The meters are the A.C. VOLTS meter M1, the A.C. AMPS meter M2 and the H.T. VOLTS meter M3. The A.C. VOLTS meter indicates the voltage of that one of the three incoming phases to which it is switched by the A.C. VOLTMETER switch SW1 on the Rheostat and Fuse Panel; the other two meters are permanently connected in the circuit. The four variable resistors (RV11-14) permit variation of grid bias on the last four amplifying stages in the transmitter without switching off.

A rear view of the cubicle is shown on the component layout with its rear door removed. Mounted behind the Meter Panel is a tray carrying all the terminal boards connecting cubicle 2 with cubicle 1, and a number of components. These are the 6.3V heater transformer (TR2) and its input limiting resistor (R2), the St.7 input limiting resistor (R4) and the 50V 3-phase rectifier (MR1). Below the tray is the bias smoothing capacitor C30.

Below the tray on the right-hand wall are the main overload relays CD-CF and their associated components.

Below the overload relays is a withdrawable panel holding the components of the general bias supply circuit and below this bias panel is mounted the Aux H.T. (230V) Supply Panel, which is also withdrawable.

On the left-hand wall below the tray are mounted the Stage 5 screen potential divider and decoupler R17, R18, R19 and C8 respectively. The connection of R19 depends on the final stage valve (see Information Leaflet No.38).

Below these are the 4 kV rectifiers V1-6 and their heater transformers TR9-14. These valves are filled with Xenon gas and will operate satisfactorily over a wide range of temperature so that a long warming-up period is not necessary.

The Stage 5 filament supply 3-phase rectifiers MR2 are mounted below TR9-14, and below the rectifiers are the TR4 preset input resistors (R8-10).

Mounted on the floor of the cabinet on the left-hand side is the 50V three-phase transformer (TR1), beside it the Stage 5 three-phase filament transformer (TR4) and beside that the Stage 5 smoothing choke (L1) and at the rear SWK, the Stage 5 polarity reversing switch. On the right-hand side are the main H.T. smoothing capacitors C9, 10, 11, 24, 25 and 26, and at the rear the main H.T. smoothing choke L7.

4.5 R.F. Unit

Component Layout Figs.9, 10, 11 and 12 (HS71/1: Figs.9A, 10A, 11A, 12A). Control Layout Fig.6.

The R.F. Unit consists of 2 cubicles, the layout of which is shown in Fig.9. The left-hand cubicle comprises the harmonic generator, mixer and power amplifier Stages 1 to 6. The right-hand cubicle contains Stage 7 and the aerial coupling circuit. The harmonic generator, mixer and amplifier Stages 1, 2 and 3 are mounted in the Mixer Unit and the amplifier Stages 4 and 5 are mounted in the 4th and 5th R.F. Amplifier Unit.

Connections to and from external units and the power cabinets are made via plugs, sockets and tagboards in the roofs of the cubicles. The primary crystal oscillator drive input is fed in via SKB, the 3.1 Mc/s signal via SKC and external drive via socket SKAC on the roof of the R.F. Unit R.H.

From the rear it can be seen that both cubicles have internal rear doors. The lower doors, which are interlocked to the filament supply, cover the high power sections of the transmitter, i.e. the anode circuits of Stages 6 and 7. The upper doors which are not interlocked cover the cathode and filament circuits of Stages 6 and 7.

The right-hand cubicle also contains the Stage 6 OUTPUT CIRCUIT unit from which Stage 7 is fed.

4.5.1 Mixer Unit

Component Layout Fig.13 (HS71/1: Fig.13B)

NOTE: *If a type HD61B Frequency Shift Diplex Equipment is used the Mixer Unit is bypassed and will have no effect on the transmitter signal, although being an integral part of the transmitter it will still function. If the transmitter is set to AUTO the wave indicator lamps will light, as the FREQUENCY switch is operated, but these will have no significance. The Monitor Frequency Changer is also bypassed, but the monitor link on the front panel is used to feed the monitor signals at radiated frequency to the monitoring receiver*

This is a separate sub-unit, located in the middle of the left-hand cubicle. It is mounted on runners to enable it to be easily withdrawn for maintenance and tuning. The unit contains the harmonic generator and amplifier stages, the mixer stage, the first three stages of the radiated frequency amplifiers and the monitor frequency changer.

The component layout shows that the unit is made up of 3 sections, these are the Mixer Unit, the Monitor Frequency Changer and the Mixer level controls. In the plan view the latter two units are shown at the right-hand side of the Mixer Unit chassis; they are the front left-hand section and the rear left-hand section respectively.

The two tuning assemblies shown on the plan view are the Harmonic generator tuning capacitors C5, 14, 25, 41 & 47 on the right and the Mixer and Amplifier Stages 1, 2 and 3, tuning capacitors C65, 66, 82, 94 and 100 on the left.

On the rear of the chassis is mounted a Ledex switch SWG, which is operated by the FREQUENCY switch on the front of the R.C.U. (R.H.) and selects the frequency to be operated by remote operation of a Ledex switch in the Crystal Drive units. It also lights the frequency indicator lamps on the control panel on the R.C.U. (R.H.).

Also on the rear of the chassis is the r.f. output plug SKQ, the Ledex and indicator lamps plug PLP and the power input plug PLN. In HS71/1 an r.f. filter is connected in the leads to PLN to exclude stray r.f. from these low level stages.

On the top of the chassis are mounted the remainder of the plugs and sockets, these are:-

Monitor Section	Stage 4 Monitor output socket	SKU
	Stage 5 Monitor output socket	SKV
	Stage 6 Monitor output socket (HS71/1 only)	SKW
	Stage 7 Monitor input/output socket	SKW (SKY in HS71/1)
	Monitor output socket (3.1 Mc/s out)	SKT
	Monitor bypass socket (FRAD out)	SKX
Mixer suppressor grid bias Section		
	Crystal Drive Selection Socket	SKL

HG & Mixer Section

At the rear; the DRIVE INPUT socket SKS
In the middle; the HG INPUT socket SKR

Also on the top of the chassis are mounted some of the variable controls and switches and all of the preset controls listed in Section 4.3.3.

The front panel controls are detailed in Section 4.2.3.

4.5.2 Amplifier Stages 4 and 5

Component Layout Fig.11 (HS71/1: Fig.11A)

These stages are contained in a separate sub-unit mounted above the Mixer Unit in the L.H. cubicle of the R.F. Unit. The unit is mounted on runners and is withdrawable for adjustment purposes and is interlocked mechanically with the STAGE 5 H.T. INTERLOCK switch (SWF) mounted on the panel above this unit. (See Fig.6 or 6A.)

Figure 11 shows the complete layout of all components and replaceable items listed in the component schedule.

Referring to the front view on this drawing Item 80 is the STAGE 5 TUNE control and Item 81 the STAGE 4 TUNE control. Five meters are mounted between them and a list of their functions is given in Table 3.

Table 3

Meter	Title
M1	STAGE 4 GRID PEAK VOLTS
M2	STAGE 4 ANODE CURRENT
M3	STAGE 5 GRID CURRENT
M4	STAGE 5 GRID PEAK VOLTS
M5	STAGE 5 CATHODE CURRENT

Under the meters are mounted the NEUTRALIZING control (C16) of Stage 5, the FEEDBACK control, the EXT DRIVE LEVEL control and the drive input link

The plan view of the component layout shows, at the front, the Stage 5 anode tuning coil assembly (an end view of this is shown in Sketch 0). In the back left-hand corner is the Stage 5 anode circuit range switch (SWA) which is ganged to the RANGE switch control on the upper panel of the R.F. Unit L.H.

The drive for the switch is fed by a coupling at the rear of the unit. When returning the unit to its operating position after withdrawal, care must be taken to ensure the couplings mate correctly.

The underside view of the component layout shows the Stage 4 tuning turret in the front left-hand corner. Sketch P (L in HS71/1) shows it removed from the equipment. The method of operation is that the tuning control on the front panel drives a continuously variable capacitor C12 and at the same time turns the 6-coil turret (L5 to L10). C12 turns

through its full capacity range 6 times, once for each inductor when they are switched in parallel with it. Coil changing is done automatically, by the mechanism in the end of the turret. Thus Stage 4 is tuned through the complete frequency range of the transmitter by revolutions of one control.

The details of its mechanical operation is that the front panel control drives the capacitor shaft, which drives a slotted cam. The capacitor tunes a coil during the 180° from minimum to maximum capacity and is switched out of circuit during the other 180°.

During this second 180° the slotted cam engages with one of the projections on the face of a small wheel fixed to the coil turret shaft and turns it through 60°, thus bringing into circuit the next coil on the turret.

A further cam operates during the second 180°, this cam operates an H.T. OFF switch (SWL) which is in the H.T. interlock control circuit, therefore no h.t. is applied to the turret or capacitor in this second 180°, while the coil changing is taking place.

The STAGE 5 TUNE control on the front panel turns L15, the tuning coil. Refer to Sketch O. When the coil turns an insulated jockey wheel (Ref.85) advances a contact carriage (Ref.68) along the coil and electrical contact with the inductor is made by four ball contacts on the contact carriage. For further information on HS71A see Supp.3, Section 3.5, and on HS71/1 see Supp.4, Section 4.5.2.

4.5.3 Amplifier Stage 6

Component Layout Figs.9 and 10 (HS71/1: Figs.9A, 10A)

Stage 6 takes up most of the rear of the L.H. cubicle (see Fig.9). Sketches C, D & E on Fig.10 show the layout of components around the Stage 6 valve V5. The valve is supported by its anode cooling fin assembly which fits into a cylinder at the top of the anode inductor structure (see Sketch C). On a level with the grid ring of the valve and surrounding the valve is an aluminium sheet which provides a second screen for the valve; the first being the grid inside the valve. Mounted on the sheet, which is hinged to facilitate fitting the valve, are the grid circuit components (shown in Sketch E). An air pressure switch is used in HS71/1 only to trip the transmitter in the event of failure of the cooling system (see Supp.4).

L19 is the anode tuning inductor and is accessible through the lower door in the cabinet (see also Sketch C). The tuning of this coil is much the same as that of Stage 5, the inductor being turned by the handle on the front panel (Ref.80 & 90 on Sheet 1). Once again as the inductor turns, a jockey wheel causes the contact assembly (Ref.84) to move up or down the inductor; electrical contact is through the four ball contacts on Ref.84.

In Sketch C the valve is shown in position. The anode connection is made by sprung ball contacts (Ref.35) which bear on a brass bush which is clamped to the end of the inductor. The other end of the contact springs are attached to the support into which the anode cooling fin structure fits. An end view of the coil is shown in Sketch M and indicates the connecting clamp and the arrangement of the mycalex supports on which the coil is wound.

Coupling from the anode inductor to the output circuit is made by the inductor L20, assembled around L19. (Sketch C). Its position with relation to L19 is variable by a lead screw turned by STAGE 6 COUPLING control. The entire assembly can, if necessary, be removed from the cabinet.

To cover the frequency range of the transmitter, capacitors are switched across the anode tuning coil.

These capacitors are mounted on switch assembly SWC, see sketch B on Fig.10 (HS71/1: Fig.10A). This switch assembly is chain driven by the range control on the front panel, see Section 4.6.1. For further information on HS71/A see Supp.3, Section 3.5.

4.5.4 Amplifier Stage 7

Component Layout Figs.9 and 12 (HS71/1: Figs.9A, 12A)

The right-hand cubicle contains the whole of Stage 7 and the aerial circuit. Stage 7, which is constructed in a manner similar to Stage 6, utilizes the vacated spaces of the 4th and 5th R.F. Amplifier and Mixer Units, by the inclusion in that position of the higher power aerial circuit. The front view of the transmitter shows that the cubicle has an exposed meter panel and four panels normally covered by the door.

The meter panel contains three meters which are, from left to right, the St.7 GRID CURRENT ammeter (M12), the St.7 CATHODE CURRENT ammeter (M11) and the FEEDER INDICATOR (M10).

The second panel contains the tuning controls for the cathode and feeder circuits, the mechanical description of which is given in Section 4.6; it also contains the monitor link LKA, which selects for monitoring either the input or output of Stage 7. This panel may be removed by unscrewing the retaining screws two on either side of the panel and pulling forward.

Removal of the panel reveals a chassis mounting C89 and C90, the FEEDER TUNE (gas-dielectric) capacitors (C90 only in HS71/1). This chassis, shown in Sketch J, can be removed from the cabinet only after removal of the lower adjacent front panel.

Behind the third panel is the feeder tune sub-assembly, which on removal of the top two front panels may be pulled forward along the angle runners and removed from the cabinet (a detailed view is given in Sketch K). For observation purposes this panel has a glass window in it.

The fourth panel when removed gives access to the cabinet cableform and holds the STAGE 7 & OUTPUT RANGE SWITCH. This panel is removable by unscrewing the retaining screws around its edge.

The bottom panel mounts the STAGE 7 ANODE TUNE control and the FEEDER COUPLING control. The mechanical description of these controls is given in Section 4.6. Removal of the panel reveals L31 and R21 in the Stage 7 anode supply circuit.

As already stated the Stage 7 construction is similar to Stage 6, there being two sections at the rear, an upper and a lower compartment. The lower compartment is the Stage 7 anode assembly and is, with the exception of the valve mounting, identical to the Stage 6 anode assembly.

The valve mounting in this stage accepts the two valve anode fins instead of the one in the case of Stage 6. The upper compartment is the Stage 7 low power assembly and is similar to Stage 6 but is slightly larger to enable the extra components, i.e. the Stage 7 input tune inductor L30, and the Stage 7 cathode choke L35 etc., to be accommodated. In HS71/1 a Reflectometer Test Controls Unit, described in Supp.4, Section 4.5.4.1, is used.

4.6 MECHANICAL DRIVES

This equipment uses mechanical drives to most of the large components. Most of them are straightforward couplings and gears driving single components. The following section will list the components driven and give a description of the method of driving.

4.6.1 R.F. Unit (L.H.) RANGE Control

Layout Diagram: Fig.24

This control operates:
SWA the range switch of Stage 5
SWC the range switch of Stage 6
SWD the range switch of Stage 6 output circuit.

The control handle on the front panel drives these switches through sprockets, chain-drives, couplings and gearboxes. The layout of these items is shown on Sketch A.

The chains and sprockets are accessible, in the case of the upper three, by removal of the Stage 6 Output Circuit and in the case of the lower two by removal of the cover plate above the FILAMENT INTERLOCK switch on the cubicle rear panel.

NOTE: *Only positions 2 to 5 of the RANGE switch are used on the HS71: all positions are used on the HS71A.*

4.6.2 FEEDER TUNE Control

Layout Diagram: Fig.24.

This control drives SWP, SWM and C64.

The transmission shaft from this control drives, through gears of 1:1 ratio, a cam which operates the microswitch SWM and the capacitor, C64, which has mounted on its shaft padder switch, SWP.

The control and capacitor swing through an angle of 270° . The capacitor being a butterfly capacitor turns from maximum to minimum capacity in the first and third quadrants and from minimum to maximum capacity in the second quadrant. During the second quadrant, the gear driven cam first operates the microswitch SWM, switching off the main h.t. and then SWP breaks contact with the padder capacitors C68 to C71, SWM operates again at the end of the quadrant enabling the h.t. to be switched on again.

The effect of operating this control from dial markings 0-100 (0-200 on HS71/1) is that, for a third of the scale, C64 and padders C68 to C71 tune the feeder coupling inductors, in the second third of the scale the padders are switched out, while no h.t. is on and tuning is not taking place, and in the last third of the scale only C64 tunes the coupling inductors.

4.6.3 STAGE 6 COUPLING Control

This control drives the lead screw which varies the position of L20 in relation to L19. A gearbox is mounted under the baseplate of the Stage 6 anode assembly and a transmission shaft from the 'Stage 6 Coupling' handle drives the gears and these, in turn, turn the lead screw.

4.6.4 STAGE 6 TUNE

The drive from this control to the inductor L19 is similar to that of the Stage 6 Coupling but the gears in the box turn the inductor and not a lead screw (see Section 4.6.3).

4.6.5 STAGE 5 NEUTRALIZING

The drive from the front panel for this control is through a flexible coupling cable. It is clearly shown as Ref.79 on Fig.11 in the underside view.

4.6.6 STAGE 7 INPUT TUNE Control

This control rotates the 'Cathode' inductor L30 via a gearbox mounted above the inductor. Electrical connection to the inductor is via a roller contact which is propelled by the action of the rotating coil.

4.6.7 ST.7 & OUTPUT RANGE switch

This control drives the range switches SWN & SWP. The transmission shaft of the control is coupled to a gearbox, which drives a vertical and a horizontal shaft. The horizontal shaft drives SWN direct and the vertical shaft is coupled to another gearbox which drives SWP.

4.6.8 STAGE 7 ANODE TUNE Control

This control drives a shaft coupled to a gearbox under the baseplate of the anode inductor. This gearbox rotates the inductor L33 in a similar manner to the Stage 6 tune control (see Section 4.6.4).

4.6.9 STAGE 7 FEEDER COUPLING Control

This control drives coupling inductor L34 in a similar manner to Stage 6 output coupling (see Section 4.6.3).

4.6.10 STAGE 7 FEEDER TUNE Control

This control drives through couplings a centre gear wheel which drives two gear wheels on the spindles of C89 and C90 (C90 only in HS71/1)

4.7 AIR COOLING

The r.f. stages of the transmitter are air cooled by an air cooling system originating in an external extractor fan. The fan is connected via overhead ducting to the air inlet in the roof of the transmitter.

The two r.f. cubicles form two separate ducts from top to bottom, joining the common duct at the base. The air then passes out via a vertical duct between the two centre cubicles. Each cubicle is fitted with an air filter on the rear fascia panel. (For a description of the filter see Section 11.7.)

VLM

5 CIRCUIT DESCRIPTION GENERAL

5.1 RADIO FREQUENCY CIRCUITS (HS71 or HS71/1 only. For HS71A see Supp.3, Sections 1 and 2)

Block Diagram Fig.1.

The HS71 transmitter may be used as a transmitter or a power amplifier. When used as a transmitter two signal inputs are applied to the Mixer Unit from the external equipments. One is a 3.1 Mc/s signal and the other the primary crystal drive frequency which is between 3.45 and 6.95 Mc/s depending on the frequency to be radiated (fRAD). When used as an amplifier the drive at radiated frequency is applied to the grid of stage 4 via an attenuator in the base of the 4th/5th stage R.F. Unit.

The 3.1 Mc/s and the crystal drive inputs are combined in the mixer stage of the Mixer Unit to produce the necessary radiated frequency, after the primary crystal drive frequency has been doubled or quadrupled in the harmonic generator stages. The output of the mixer stage is amplified by a seven stage power amplifier. The distortion factor of this seven-stage amplifier is minimized by an envelope correction circuit in the cathode circuit of Stage 5.

5.2 MONITORING

To facilitate correct operation of the transmitter provision is made for feeding monitor signals via the monitor frequency changer, from the mixer stage and stages 3, 4, 5 and 7, to the ISB drive unit for examination in a monitoring receiver. To do this, part of the signal required to be checked is fed via U-links to the monitor frequency changer unit, in the Mixer Unit and there combined with a part of the final frequency output of the harmonic generator stages to be returned to a signal suitable for feeding to the monitor unit in the drive rack (see Supp.3, Section 3.6 for HS.71A). When using an external drive whose output is the radiated frequency, the monitor signals are fed back at radiated frequency using the by-pass link SKX, as the monitor frequency changer is non-operative.

5.3 POWER SUPPLIES

Block Diagram Fig.1.

All the various power supplies are derived, rectified and smoothed in the rectifier and control units, the input supply being 380/440V at 50 or 60 c/s three phase AC (see Section 2 for power consumption).

The various HT and filament supply circuits are switched on and off by a sequenced control circuit of relays and contactors. The sequence is initiated by push button switches on the control panel for local operation and a switch on the remote control panel for remote operation.

The control circuits are energised by a 50V DC supply, the positive side of which is earthed. This supply is switched by the mains isolator switch and produced by a conventional three phase transformer and bridge rectifier.

Incorporated in the control circuits is an overload protection circuit which when an excess of current flows in any of the rectified main HT output lines (three) will break the supply to the main HT transformer and also isolate the main HT press button switch, thus allowing main HT to be replaced only after investigation of the overload.

6 CIRCUIT DESCRIPTION DETAILED

To enable quick reference to any given component on a diagram a system of grid referencing is used, e.g. SWC(2A) on Fig.20 refers to switch SWC located in the square found by 2 horizontally and A vertically on the drawing specified.

6.1 RECTIFIER AND CONTROL UNIT

Circuit Diagram Fig.20.

This unit provides all the necessary power for the transmitter operation. All circuits are conventional rectifier circuits either single or three phase.

On switching SWA(8C) the MAINS ISOLATOR switch to on, the 50V relay supply is energised, (the 50V supply having no ON/OFF switch of its own).

supply is energised, (the 50V supply having no ON/OFF switch of its own). This allows the three phase voltages and the filament supply voltages to be checked by the means described in Section 8 without operating the HT EARTHING switch, SWB and the HT INTERLOCK switch SWP.

These two switches SWP and SWB isolate the bias and HT supplies from the AC input or earth the rectified output to ensure that the transmitter is safe before the doors can be opened. On switching SWB to OFF the safety earths are removed from the auxiliary and Main HT output lines, and switching SWP to CLOSED primes the auxiliary HT contactor LA and the input circuits to the general and stage 7 bias supplies.

SWG(3B) the Remote/Local switch provides for remote or local switching ON or OFF of the transmitter. In the local position SWC(2A) the press button start switch switches-on the equipment, in the remote position relay SP by-passes the START switch, and its contact SP1 will switch on the equipment.

6.1.1 Filament Supplies

There are 4 filament supplies produced in this unit for various stages of the transmitter. Stages 5, 6 & 7 have separate filament transformers etc. and the Mixer Unit and Stage 4 are supplied by the 6.3V AC filament transformer TR2.

Mixer Unit and Stage 4

This filament supply is 6.3V AC and is produced by a step-down transformer TR2(3F). Its input limiting resistor R2(7F) also limits the input to TR7(6L) the filament transformer of V7 & V8 the Auxiliary HT rectifier valves.

The input supply to the transformers is switched by FC1(8F) operated by the FC relay in the control circuit (see Section 6.3.1).

Stage 5

This filament supply is 5V DC and is produced by the 3-phase transformer TR4 and the bridge rectifier MR2. The output supply is choke smoothed by L1(3C) and a polarity switch SWK(2G) is provided for changing the polarity of the valve supply every week of operation. The input supplies have limiting preset resistors R8, R9 and R10(6G) for correcting the output voltage.

Stage 6

This filament supply is 12.6V DC and is produced, in the same manner as that for Stage 5, by TR17 and MR8. No smoothing is done in this unit but a polarity switch SWQ(2H) is included as for Stage 5. The input supply is limited by preset resistors R22, R23 and R24(6H).

There is a common mains input to Stage 5 and 6 filament transformer and to the Main HT rectifier heater transformers RV2, 3 and 4(8G) vary the input voltage and FC4, 5 and 6 switch the supply ON or OFF.

Stage 7

This filament supply is 12.6V AC and is produced by TR3(3F). The input to the transformer is taken from across the Red and Yellow Phases to limit the current flow through FC2 and 3 and FF1. The input supply is

switched on by FC2 and FC3 and is limited by RV1 and before the bias supplies are switched on by FF, by R4.

This period is of 30 seconds duration and is controlled by the time delay switch FD.

It will be noted that all the filament switching is done by the FC contactor in the control circuit and its operation will be described in Section 6.3.

6.1.2 Bias Supply

There are two bias supplies, one for the RH, RF cubicle and one for the LH, RF cubicle.

The LH, RF cubicle bias is produced by TR5(6I) and MR3(5I). The output is smoothed by L3(5I), L2(4I), C2, C3 and C4(4I), and stabilized by V10(3I). The required bias voltages for Stages 4, 5 and 6 are tapped off from the variable resistors RV11-13, and the mixer suppressor bias from across the stabilizer V10.

The RH, RF cubicle bias is produced by TR16(5J) and MR7(4J) and the output is smoothed by L9(4K), L8(4K) and C19-23(3 & 4J). Across the output is the bleeder network comprising R21 (two separate sections) R59 and the variable resistor RV14, from which grid for Stage 7 is tapped off.

6.1.3 Auxiliary HT Supply

This supply is a normal full wave rectifier circuit giving a smoothed output of 250V DC and a stabilized output of 280V; TR6 is the HT transformer and TR7 the rectifier filament transformer. V7 and V8 are the rectifiers and V9 the stabilizer. The supply unit to TR6 is switched on and off by LA2(7K) and the 450V output line is earthed by SWB2(7L) when the HT earthing and HT interlock switches on the control panel are off, this ensures that when the doors are opened no lethal voltage exists within the cubicle.

6.1.4 Main HT Supply

This supply is a normal 3-phase valve rectifier circuit with provision against the valves being overloaded.

The input is switched by MC1, 2 and 3 and there is also a high/low HT switch, SWJ(9L), in the blue phase feed. On low HT only the red and yellow phases supply the transformer giving approximately 2/3 HT.

The smoothing circuit consists of L7 and C9, 10, 11, 24, 25 and 26. Across the output is R29 the meter multiplier of M3, the Main HT Meter. There is a contact of the HT earthing switch SWB across the 4 kV output from the smoothing circuit this earths the 4 kV line when no mains supply is applied to the cabinet rendering the cubicle safe when the doors are opened.

The 4 kV divides into 3 outputs, one to Stage 5 (TB3), one to Stage 6 (TB2) and one to Stage 7 (TB4). In each case an overload relay is in series with the supply so that any excess of current in the 3 stages fed will cause one of these relays OD, OE or OF to operate before the rectifier valves are damaged.

The overload circuits are described in Section 6.3.

6.2 RF UNIT

Circuit Diagram Figs.16 and 17.

6.2.1 General

The HS.71 transmitter may be used as a transmitter or a power amplifier. When used as a power amplifier the external drive is applied to the control grid of Stage 4 via SKCA. When used as a transmitter there are two RF inputs applied to the transmitter. One is from the primary crystal oscillator and is between 3.45 and 6.95 Mc/s. It is applied to the harmonic generator stage of the Mixer Unit where it is either doubled or quadrupled, the resultant, described at the harmonic generator frequency (fHG), is then passed to the control grids of the balanced Mixer Stage. The other input is the 3.1 Mc/s signal to be transmitted and is applied to the cathode circuit of the balanced mixer stage.

The sum and difference components of the two inputs appear simultaneously in the anode circuit of the mixer and the required carrier is selected by the anode circuit of the mixer. This selected carrier is the frequency to be radiated and is applied through the seven amplifier stages to the aerial feeder circuit.

For radiated frequencies (fRAD) up to 10 Mc/s, the difference frequency output of the mixer is used, i.e. $fHG - 3.1$ Mc/s, where fHG is the frequency of the harmonic generator output and 3.1 Mc/s is the modulated input. Above 10 Mc/s, the sum frequency is taken from the mixer, i.e. $fHG + 3.1$ Mc/s. The harmonic generator is therefore required to supply frequencies ranging from 7.1 Mc/s (fRAD = 4 Mc/s) to 24.4 Mc/s (fRAD = 27.5 Mc/s).

The primary crystal drive input to the harmonic generator covers a range of 3.45 to 6.95 Mc/s, therefore for radiated frequencies up to 17 Mc/s, the harmonic generator must multiply by two the input drive (maximum if fHG = 13.9 Mc/s). Above 17 Mc/s the harmonic generator multiplies by four.

6.2.2 Harmonic Generator

Circuit Diagram Fig.18.

NOTE: *Not used when the transmitter is driven from an external drive source.*

The harmonic generator is part of the Mixer Unit and consists of three frequency multiplier stages V1, V2 and V3 followed by two amplifier stages V4 and V5/V6 in parallel.

The frequency multiplier stages V1, V2 and V3 are biased for ease of selecting the second harmonic of the valve input frequency and the anode tuned circuits of these stages tune over individual frequency ranges; V1 over the range 4 to 8 Mc/s, V2 over the range 8 to 16 Mc/s and V3 over the range 16 to 24.4 Mc/s. Various combinations of the multiplier stages are selected by SWA, the harmonic generator frequency range switch (fHG Mc/s), to give an output frequency of twice or four times the primary crystal oscillator frequency (fxtal). These combinations are shown in Table 4.

Table 4 *

SWA range	fxtal Mc/s	Function			fHG Mc/s	Remarks
		V1	V2	V3		
4/8 Mc/s	3.5 -4	Doubler	-	-	7.1-8	
8/16 Mc/s	4 -6.95	Ampl.	Doubler	-	8 -13.9	
8/16 Mc/s	3.475-4	Doubler	Doubler	-	13.9-16	
16/24.4 Mc/s	4 -6.1	Ampl.	Doubler	Doubler	16 -24.4	

* HS.71 only. For HS.71A see Supp.3, Table 2.

SWA also selects the appropriate anode tuned circuit of the amplifier stages V4 and V5/V6 and switches the required final harmonic generator frequency to the control grids of the balanced Mixer Stage.

Metering facilities are provided by SWB (HG METERING) and M1. On position 7 of SWB the meter is switched to SWD (MIXER METERING) and provides metering facilities for the Mixer Stage Stages 1, 2 and 3 and the monitor frequency changer.

6.2.3 Mixer Stage

Circuit Diagram Fig.19.

NOTE: *Not used when the transmitter is driven from an external drive source.*

The Mixer Stage comprises V7 and V8 in a balanced circuit. The two inputs, one from the drive equipment at 3.1 Mc/s and the other from the harmonic generator at 7.1-24.4 Mc/s, are fed to the cathodes and grids respectively. The mixed output is: balanced by C63 and RV1, tuned by C65 and C66 and selected by one of three anode tuned circuits TR6/C67, TR7/C68 or TR8/C69.

These tuned circuits are selected by the Mixer range switch SWC and select the radiated frequency which is given by the sum of the two frequencies above 10 Mc/s and the difference of the two frequencies under 10 Mc/s.

The output level of the transmitter is adjusted by the level control (MANUAL) or preset controls RV6-11 in this stage. These potentiometers, individually, vary the suppressor grid voltage and thus the stage output. When SWF the MANUAL/REMOTE switch is in the MANUAL position (as drawn) RV5 adjusts the level and when in the REMOTE position the preset potentiometers RV6-11 may be set-up for the different levels required on each of the six predetermined frequencies.

6.2.4 Stages 1, 2 and 3

Circuit Diagram Fig.19.

NOTE: *Not used when the transmitter is driven from an external drive source.*

The output of the mixer stage i.e., the intelligence at the radiated frequency, is transformer coupled by TR6, 7 or 8 (selected by the frequency range) to the control grid of the first amplifier stage V9(7E) via SWC13(6D). V9 is a buffer amplifier stage operating in class A. Its output is fed via SWC9(6G) on Stage 2, V10, operating in class B. V10 is followed by Stage 3, V11, also operating in class B.

SWC, the frequency range selection switch, selects the anode tuned circuit in all these stages as well as the anode tuned circuit of the Mixer Stage.

The tuning capacitors for each stage C82(5F) for Stage 1, C94(5G) for Stage 2 and C100(4H) for Stage 3 are part of the 'MIXER TUNE' capacitor assembly, driven by the control on the front panel.

The RF output, from Stage 3 is fed via SWC1 and SWC2(6J) to the coaxial output socket SKQ. A small portion of the RF output is also fed to PLBE(1J) via R109(5J). PLBE is one of the monitor plugs which can be linked by U-link LKA(7J) to the input of the Monitor section.

6.2.5 Monitor Frequency Changer (HS.71 only. For HS.71A see Supp.3)

Circuit Diagram Fig.19.

The monitor frequency changer is part of the Mixer Unit. Its input is selected by the position of LKA(1J). The unit consists of V12 a frequency changer and V13 a buffer amplifier.

The control grid of V12 is connected to the output of the harmonic generator stages SWA15(6M Fig.13) and the cathode is connected to PLBC(1J) the radial centre of LKA. Therefore depending on its position a monitoring signal at the radiated frequency is fed into the cathode of V12. The two signals are mixed through the valve and the difference frequency of 3.1 Mc/s is selected in its anode tuned circuit. This 3.1 Mc/s signal is then fed via C131(3K) to the buffer amplifier V13 where it is amplified and fed to the monitor output socket SKT(2M).

SKX in parallel with plug PLBG is the radiated frequency monitor output socket which is used when external drive between 4 and 27.5 Mc/s is applied to the transmitter. It connects the monitor signals to the monitor frequency changer and receiver in the external drive rack, bypassing the HS.71 monitor frequency changer which is inactive owing to no harmonic generator frequency.

6.2.6 Stages 4 and 5

Circuit Diagram Fig.16.

The input to Stage 4 may be either from an external drive or from the internal mixer unit. These two inputs are fed to the selector link LKB on the front of the unit; the internal mixer output via coaxial plugs and sockets PLH, SKH, PLQ and SKQ and the cabinet cableform; and the external drive from the socket SKCA on the roof via the cabinet cableform to socket SKK on the rear of the unit. From this socket the drive is attenuated to the required level by the network R40 to R58 and fed to the link plug PLCB.

Stage 4 consists of V1(4G) and V2(4H) in parallel, operating as Class A Amplifier. The stage operates from the auxiliary HT via plug PLJ2(7E), and grid bias is developed across the variable resistor RV11 forming part of the bias supply unit.

The signal input strength to the stage is indicated on the meter M1(6F) via the Peak Voltmeter Unit PVM1(4F).

The output is fed via C8(3H) and tuned by C12(3I) in conjunction with the coil turret L5-10(3-7H) to the input circuit of Stage 5. A band spread capacitor C13(4H) is added to the tuned circuit of the highest range. For mechanical description of coil changing see Section 4.5.2. In the output circuit of Stage 4, is the monitor pick-up capacitor C15(4I) which is connected via SKM(2E) to SKU(2D) the Stage 4 Monitor Socket on the Mixer Unit.

The signal input strength to Stage 5 is indicated by the meter M4(5I) via the Peak Voltmeter Unit PVM2(5I).

Stage 5 consists of V3(4J) and V4(4J) in parallel operating in class 'AB'. This stage operates from the main h.t. (4 kV). Screen voltage is supplied by the potentiometer network described in Section 4.4.1. Grid Bias is fed from the R.C.U. via PLJ10(7I), the meter resistor R13(6I), L11(5I) and Stage 4 tuned circuit.

Cathode current is metered by M5(6J) shunted by R19(6J). The anode tuned circuit is the variable inductor L15(4L) and the three fixed ceramic capacitors C32*, C33* and C34* (4K) or the self capacitance of the valve. The circuit shows the Range Switch SWA(4K) in range 1 position (i.e. the lowest frequency range, not normally used on HS71).

HS71 and
HS71/1
only.
For HS71A
see Supp.
3, Sect.
3.4

On this range C32 and C33 are in parallel across L15, on the next position C33 only is across L15 and on the third range C33 with C34 in series with it are across L15 and on the last two ranges the self capacitance of the valve only is across L15.

Stage 5 neutralizing is effected by a capacitor bridge consisting of Cag, Cge, C24 and C17 and C16 in parallel. C16 is variable, by the NEUTRALISING control on the front panel. Adjustment of this control is only required when setting up initially and holds over the whole frequency band.

A high degree of linearity is obtained in the amplifier stages, by use of an envelope distortion correction circuit in the cathode circuit of this stage. The action of the envelope distortion correction circuit is as follows.

The cathode connection to the valves V3 and V4 is made via 2 resistors R25 and R26(6J) one to each cathode. Their common junction point is connected via R27, L29(5J) and RV2(6K) in parallel and R19, the M5 meter shunt, to earth.

These components do not produce any effective d.c. bias as L29 has a low d.c. resistance compared with R27 and RV2. An a.f. voltage appears across the combination, determined in magnitude by the value of R27 and RV2 in parallel with the choke L29. This a.f. component modifies the screen-cathode voltage on the valves in a direction to reduce the inherent distortion produced in the valves.

The output of Stage 5 is fed via C37 and/or C35 to a spring contact X2 (3L) on the rear of the chassis. (See also Supp.3, Table 3.)

6.2.7 Stage 6

Circuit Diagram Figs.16 & 17 (HS31A: Figs.16A, 17A) (HS71/1: Figs.16B, 17B, 17C)

This stage consists of a single triode V5 in a grounded grid circuit. This arrangement avoids the need for neutralisation, as the anode to grid capacitive currents due to the output voltage do not flow through the input circuit. In addition, the stage linearity is improved as the stage has a low, and appreciably constant, input impedance and thus variations of the grid current over the r.f. cycle do not appreciably affect the regulation of the driving stage.

AP.116E-0232-1
A.L.5 Apr. '67

*HS71 and HS71/1 only

The Stage 5 coupling C37 and/or C35 form a capacity potentiometer with C39(3M) and/or C45(2M) and the input to Stage 6 is taken from the junction of these capacitors. C45 also presents a low impedance path to harmonics of the input frequencies, thus enhancing stage efficiency.

For HS71
and HS71/1
only. For
HS71A see
Supp.3
Sect.3.5

The stage filament supply is isolated from the r.f. by a filament choke L17(4M). L17 is wound from concentric cable (Pyrotenax) and one side of the supply is connected to the inner conductor and the other side to the outer conductor, and the filament is connected in a like manner at the other end of the choke.

The cathode circuit is grounded via the centre tap of RV1(4M) and the cathode current meter shunt R22(5M). The grid is earthed to r.f. by C43 and C44 and C48 and C49. Grid bias is applied via L18(4N), the grid current meter and shunt R23, from the bias section in the R.C.U. The HS71/1 has an extra relay (see Supp.4, Sect.6.2.7) which operates on excessive grid current.

The anode tuned circuit is L19(30) and the capacitors C56, 57, 58 or the self capacitance of the valve on Positions 1 to 5 respectively.

The range switch (SWC) is driven by the main Range Control on the front of the cubicle (see Section 4.6.1).

The stage h.t. is 4 kV and is supplied from TB2 on the R.C.U. (see Section 6.1.4). The supply is isolated from r.f. by the r.f. chokes L21(40) and L28(50) decoupled by C59 and C60(50).

The output is transformer coupled to the Stage 6 output circuit by the action of L19 and L20(30).

6.2.8 STAGE 6 Output Circuit

Circuit Diagram Fig.17.

The coupling coil L20(30 Sheet 1) is tuned by the split stator capacitor C64(5C) and SWP adds C68, C69, C70 and C71(5C) fixed capacitors on various frequency ranges (see Section 4.6.2). The fixed series inductors L22 and L23 assist the tuning on frequency Ranges 1, 2 and 3, no inductor is added to the coupling coil on Range 4 and on Range 5 a paralleled inductor L26(5C) is added. These inductors are selected by the range switch SWD, which is operated by the RANGE control on the front of the cubicle.

The output Stage 6 is taken via a spring contact X7(6D) to the input of Stage 7 in the right-hand, r.f. cubicle. The HS71/1 has an arc suppression circuit (see Supp.4, Section 6.2.8).

6.2.9 STAGE 7

Circuit Diagram Fig.17 (HS71A: Fig.17A) (HS71/1: Fig.17B)

This stage consists of a pair of triodes, V6 and V7(5G), paralleled in a grounded grid circuit similar to Stage 6. The main difference between the two stages is that the cathode input capacity is tuned by L44 and/or L30 and the filament centre tap resistor, R33, is fixed and not variable as in Stage 6. The stage h.t. is 4 kV and is supplied from the R.C.U. via TB5(1G). The bias is also obtained from the R.C.U. and is fed in via PLBA(9J) where it is fed via M12(6J), the St.7 GRID CURRENT meter and L36 to the grid of the valves. Cathode current is measured by M11 (8H) shunted by R34(8H). See also Supp.3, Section 3.5.

6.2.10 The Output Circuit

Circuit Diagram Fig.17 (HS71A: Fig.17A) (HS71/1: Fig.17B)

For HS71/1
see Supp.4
Section
6.2.10

The output circuit matches the final stage output to a 600 Ω balanced feeder, or 50 Ω coaxial feeder as appropriate. The tuning of the coupling coil L34 is done by C89 and C90(41) two gas filled variable capacitors (only C90 in HS71/1). On the lowest frequency ranges (Ranges 1 & 2) L37 and L38 are in series with L34, on Range 3 C89 and C90 tune L34 only and on Ranges 4 and 5 additional parallel inductors L39 and/or L40 are introduced to the circuit. (See also Supp.3, Table 3).

All these circuit changes are made by SWR controlled by the STAGE 7 & OUTPUT RANGE control on the front panel.

6.2.11 Monitoring Stage 7

Circuit Diagram Fig.17 (HS71A: Fig.17A) (HS71/1: Fig.17B)

Part of the signal input and output of the stage is fed via C74(6F) and C93(3J) to the monitor plugs PLBC & PLBE (PLCJ and PLBB in HS71/1) and from these, dependent on the setting of LKA in the R.F. Unit, to U-link plugs on the front of the monitor section of the Mixer Unit, where selection of input to the monitor amplifier V1/V2 is made.

6.2.12 Feeder Indication

The signal output to the aerial feeder is measured from pick-up by C94(4J), by M10(5J) via the Peak Voltmeter Unit PVM4.

6.3 CONTROL CIRCUITS

6.3.1 Switching-on Sequence

Circuit Diagram Fig.23 (HS71/1: Fig.23B)

This section covers the sequence of operation of the control circuits only.

Close the OUTPUT TUNE, St.4 TUNE and the St.5 H.T. INTERLOCK switches.
Close the polarity switches SWK and SWQ.

Close the FILAMENT INTERLOCK switches SWN and Q on the Stage 6 and Stage 7 valve compartment.

Close and lock the doors and insert keys in the control panel.

Close the MAINS ISOLATOR switch SWA and H.T. INTERLOCK switch SWP and open the H.T. EARTHING switch SWB; the 50V indicator lamp will light.

Press the START button SWC and a 50V circuit will be made via SWG, the FILAMENT INTERLOCK switches in the r.f. cabinets energizing contactor ST.

ST1 Closes and takes the place of the START switch.

ST4 Closes and switches on the Fan.

ST2 Closes and operates the filament contactor FC when the Air Switch has been closed by the air pressure from the fan.

ST3 Closes and primes the main h.t. contactor MC.

ST5 Closes and primes the main h.t. contactor and overload relay or the filament contactor FC operates and

FC1 Closes and energizes the 6.3V filament transformer TR2

FC2 } Closes and energizes the Stage 7 filament transformer TR3
FC3 }

FC4)
 FC5) Closes and energizes the Stage 5 filament transformer TR4.
 FC6)
 FC7 Closes operating the time switch FD.
 FC8 Closes priming the bias contactor FF.
 FC9 not used.
 The time switch FD is powered and
 FD1 Closes after 30 seconds, energizing FF.
 FD2 Closes after 35 seconds, operating LA (as FF3 will close during the 5-second interval).
 The bias and full filaments contactor FF operates and
 FF1 Closes shorting out dropping resistor R4.
 FF2 Closes switching the general bias circuits on.
 FF4 Closes lighting the FILS ON lamp.
 FF5 Closes switching the Stage 7 bias circuits ON.
 FF3 Closes priming the aux. h.t. contactor LA (see FD2 above)
 The auxiliary h.t. contactor LA operates and
 LA2 Closes energizing the aux. h.t. transformer TR6.
 LA3 Closes priming the main h.t. contactor MC.
 LA4 Closes lighting the aux. H.T. ON lamp (LA1 and LA5 are not used).

NOTE: Interlock Circuits

In the standard transmitter, a shorting link is connected across Terminals 1 & 2 of tagboard TB5. By removing this link, an external feeder switching interlock circuit can be connected, via the terminals, in series with the main h.t. contactor.

The main h.t. can now be switched ON by the press button H.T. ON (SWE)
 On depressing SWE a 50V circuit is made through MC (in HS71/1, depressing SWE energizes the Interlock Pilot Relay ILR via a contact of the trip relay in the reflectometer circuit and a closed link which can, if necessary, be removed to add external interlocks.

The main h.t. contactor MC operates and

MC1-3 Close the 3-phase supply path to the h.t. transformer TR8.
 MC4 Closes shorting out the H.T. ON button (SWE).
 MC5 Closes lighting the main H.T. ON lamp.
 MC6 Opens inserting the economy resistor R28 in series with MC.
 Full power is now applied to all circuits.

6.3.2 H.T. OFF

To switch the main h.t. off depress the OFF & RESET button.

This will break the supply to contactor MC (also to ILR in HS71/1). MC de-energizes and all its contacts open returning the main h.t. control circuit to the de-energized condition.

6.3.3 Overload Circuits

Circuit Diagram Fig.21 and Fig.23 (HS71/1: Figs.21A, 23B)

The last three stages of the r.f. amplifier each have overload relays in their anode supply circuits. These relays, OD for Stage 5, OE for Stage 6 and OF for Stage 7, are set to operate when excessive current is drawn from the 4 kV h.t. supply. The relay operating current is set by the relay tensioning springs and a shunt variable resistor RV6.

When an overload occurs, i.e. a stage draws excessive current, the overload relay will be energized, causing its associated contacts to change over.

The relay contacts OD1, OE1 and OF1 are connected in series in the control circuit of the main h.t. contactor MC; they are normally closed, opening on an overload. Contacts OD2, OE2 and OF2 are connected in parallel in the operating circuit of the overload trip relay OR; these are normally open, closing on an overload.

When an overload occurs, the supply to MC is cut off. MC is de-energized and all its contacts open, isolating the main h.t. circuits and its own supply line from the supplies.

While this is taking place OR is energized and

- OR1) Opens the supply circuit of MC.
- OR2) Closes in the supply circuit of relay OR.
- OR3 Closes and lights the TRIP lamp.
- OR4 Closes and rings the alarm, both remotely and locally (if fitted).
- OR5

The operation of OR1, OR2 and OR3 ensures that the H.T. ON switch does not control the supply to MC after an overload has occurred. This is because the necessary trip relay will have been later de-energized by the de-energizing of MC. In HS71/1 arc suppression and grid current overload circuits are also used (see Supp.4, Section 6.3.3.1).

In the case of HS71/1 the contact breakers CB will trip if excessive current is drawn from the three-phase supply by H.T. transformer TR8 (Fig.20B). Three of these contact breakers will cut off the three-phase supply to TR8 while a fourth, which is wired in series with the reflectometer trip relay RL1A1, opens, operating relay SP. Contact SP1 operates overload relay OR as detailed above.

6.3.4 Trip Reset

To reset the main h.t. after an overload, depress the H.T. OFF & RESET button, this breaks the supply to the overload relay OR. OR de-energizes and all its contacts return to the rest position, thus the main h.t. circuit is complete as far as the H.T. ON button.

Press the H.T. ON button and the main h.t. will be switched on in the normal way. In HS71/1 this depends on Contact Breaker CB1 being still 'on'; if it has tripped it will be necessary to switch the transmitter off and open the L.H. R.C.U. to reset it.

6.3.5 Remote Control

NOTE: *The provision for Remote Control has been removed in order to provide additional auto-alarm facilities. It may be restored to its pre-modification state by reference to A.P.2922E, Vol.2.*

Switching ON and OFF by remote control is provided by the relay SP. Its method of operation is that when the REMOTE/LOCAL switch SWG is switched to REMOTE the contact SP1 replaces the START switch, STOP switch and contact ST1. Switching the main h.t. on will, on remote, be done by contact LA3 as the H.T. ON switch is bypassed by a switch on SWG.

The supply to operate SP is supplied by the internal relay supply via FS22, SWG2 and the remote ON/OFF switch.

6.3.6 Frequency Selector Control Circuit

Circuit Diagram Fig.23 (HS71/1: Fig.23B)

NOTE: *This section is not applicable when an external drive is used.*

A control circuit in the transmitter will, when the MANUAL/AUTO switch SWN is set to AUTO, select the primary crystal oscillator required for use. The transmitter 50V relay supply is used to operate a Ledex switch in the HD21 rack. The control circuit of this Ledex is on the Ledex switch SWG in the Mixer Unit, which is controlled by the frequency switch SWL in the Rectifier and Control Unit (R.C.U.).

On switching SWN to AUTO the 50V relay supply is connected to SWC4 in the Mixer Unit and to the FREQUENCY selection switch SWL on the front panel of the R.C.U. On setting SWL to the desired frequency, the Ledex SWG in the Mixer Unit, by step-by-step motion, turns the switch to the desired frequency. In doing this it sets in motion, by completing the control circuit, the Ledex switch in the HD20 rack which, also by step-by-step motion, selects the desired primary crystal oscillator.

This facility cannot be used when the local/remote switch SW9 is set to remote.

6.3.7 Switching off

To switch off the transmitter two steps are necessary: (a) press the H.T. OFF button, relay MC de-energizes (see Section 6.3.2) and (b) press the STOP button and all the control circuits will revert to the rest (de-energized) position, leaving only the 50V d.c. supply on. This would normally be left on during a temporary close down. To close down completely the H.T. INTERLOCK switch SWP, the H.T. EARTHING switch SWB and the MAINS ISOLATOR switch SWA would be turned to OPEN, ON and ISOLATED respectively, in which positions the transmitter will be completely off.

7 INSTALLATION

Installation requirements differ according to site conditions and each specific installation will normally have supplied its own Installation Folder, containing full instructional drawings. The following, therefore, should be regarded as general guidance rather than specific instructions.

7.1 GENERAL

A site plan is invariably included in the installation folder. The transmitter room must be dry and well ventilated.

The overall dimensions of the transmitter are given in Section 2.1. Care must be taken when siting the transmitter to provide sufficient access on all sides to facilitate the fitting of large components and to allow the doors to be fully opened and units to be withdrawn for maintenance and adjustment.

Provision must be made for running mains supply, traffic, telephone and control leads.

7.2 PACKING, TRANSPORT AND DELIVERY

The equipment is carefully inspected and tested prior to despatch. When it is disconnected and packed for transport, all heavy items are removed from the cabinets and packed separately. The wiring in the cabinets and the inter-unit wiring is disturbed as little as possible.

A.P.116E-0232-1

A.L.9, Feb.1971

Where the wiring must be removed, the cable ends and their respective terminal points are marked with corresponding numbers. The cabinets are suitably braced internally to withstand transport.

The serial numbers of the cases and their contents will be clearly indicated on the Advice Notes and Packing Notes. The latter are usually inserted in a tin compartment on the crate or case. Any irregularities should be endorsed on the carrier's documents and the Company or its authorised agents notified immediately. Where damage has occurred, the case, its contents and the packing should be retained for examination.

The cases are despatched in a weatherproof condition; however, it does not necessarily follow that they are in that condition on arrival. Therefore, should installation be delayed, the equipment should be stored under cover as soon as possible.

7.3 ASSEMBLING THE TRANSMITTER

The cabinets are to be mounted on a wooden plinth; the surface of this must be level otherwise difficulty will be experienced in opening doors, operation of door switches etc. The rectifier and control cabinet is mounted on the left.

Fit transformers and other heavy items which will have been removed for purposes of transport. NOTE that transformers are not screwed down but are placed on pegs for easy fitting.

The a.c. input enters via TBl in the top left (viewed from the rear) of the right-hand rectifier cabinet - see Fig.7. The external connections to and from the r.f. cabinets are made via plugs and sockets on the roof.

Connect up the inter-unit wiring. A diagram of inter-unit connections is shown on Fig.22*. Connections between the Rectifier Cabinets and the R.F. Cabinets are made from terminal boards in the top of the Rectifier Cabinets to the plugs and sockets on the roof of the R.F. cabinets. Connection between the various sub-units in the L.H. R.F. Cabinet is by plugs and sockets. The wiring is carried on channels inside the cabinet and will not normally be disturbed, therefore simply connect up each sub-unit as it is fitted. The connections between sub-units are best seen on Figs.16 and 17, the r.f. unit circuit diagram in conjunction with the main inter-unit connections diagram Fig.22.* The disposition of the various plugs and sockets may be seen on the relevant component layouts. Fit sub-units, meters and such other components as have been removed for packing and transport.

Check wiring by 'ringing through' or some other quick method. Take care not to 'ring through' any meters.

Check the fuses using the list given in Section 11.6. Check for continuity as well as correct rating.

* Fig.22A for HS71/1

7.4 INSTALLING THE VALVES

Fit the valves to the list given in Table 1 in Section 3. Ensure that connections are tight and where flexible connectors are used ensure that there is no strain on those which might damage the seals of the valves.

7.4.1 Fitting the BR191 Valve[Ⓜ] (Stages 6 and 7)

- (1) Open the r.f. cabinet rear door and the stage cathode compartment door.
- (2) Remove the three wing nuts on the front of the valve connectors and lift the connector assembly off the capacitor caps.
- (3) Undo the fasteners and open the grid deck and clip it up by the catch on the cabinet wall.
- (4) Insert the BR191 cooling fins into the recess with the metal seal towards the rear of the cabinet.
- (5) Lower the grid deck and fasten down.
- (6) Check (a) that the capacitor caps are in their correct position,
(b) that all wing nuts are tight.
- (7) The valve is now installed.

[Ⓜ] For ACT70 valves see Section 11.12.

8 SETTING UP

After installation, before any attempt is made to operate the transmitter, it must be systematically checked, commencing with the interlocks and control circuits and working through filaments, bias and auxiliary h.t. supplies to the main h.t. supply.

8.1 PRELIMINARY

Check that the primary taps of all transformers, except TR9-14, are correct for the mains supply in use. In order to obtain adequate control on STAGE 5 and RECTIFIER FILAMENT regulators, the primary taps on TR9-14 must be set to 20 volts less than the mains voltage. The tapplings are shown in Table 5.

Table 5

Ref.	Identity		Primary Tap				
	Drawing No.	Sheet	240V	220V	200V	0	+10V
TR2	W.24068	59	13	11	9	5	3
TR3	W.24582	13	18	16	14	6	4
TR5	W.23241	33	11	11	9	5	3
TR6	W.24586	26	13	11	9	5	3
TR7	W.24743	27	7	6	5	3	2
TR9-14	W.27206	4	14	12	10	5	3

- (1) For 4.05-4.1 kV the secondary taps on the h.t. transformer, TR8, must be set to the 3000V terminals.
- (2) Check the zero settings on all meters and adjust as necessary.
- (3) Set the following control switches:- AUTO/MANUAL switch to AUTO.
LOCAL/REMOTE switch to LOCAL.
- (4) Push the Stage 4/Stage 5 sub-unit firmly into the r.f. cabinet and set the STAGE 5 H.T. INTERLOCK control to 'WORKING'.
- (5) TEST EQUIPMENT required. External voltmeter with 1% accuracy.
- (6) Check that TB5(1) and (2) are linked either directly or via the external interlock circuit.

8.2 CHECKING RELAY AND CONTACTOR OPERATION

The control circuits are explained in Section 6.3, to which reference should be made.

- (1) Remove fuses FS5-FS12 and FS14-17 (see Fig.8)*. This will isolate the filaments and h.t. circuits and allow the operation of the various relays and contactors to be checked without the supplies they control being switched on. Check that TB5/1 and 2 are linked.

*In HS71/1 ensure that CB1 is at OFF.

- (2) Close the external isolator switch. Set the STAGE 5 OUTPUT TUNE and ST.4 TUNE to 0. Set FREQUENCY switch to A.
- (3) Close and lock the front and rear doors of the rectifier cabinets and remove the keys from the locks and place in position on the control panel.
- (4) Operate the MAINS ISOLATOR switch (SWA) on the control panel. The A.C. VOLTMETER (M1), on the meter panel at the top of the right-hand rectifier cubicle, will now indicate. Using its selector switch (SWH) on the h.t. and filaments control panel, check the voltage of each phase of the supply. The 50V d.c. indicator lamp (LP1) and frequency lamp A(LP6) will light. Check that none of the doors specified in (3) can be opened without first switching off the MAINS ISOLATOR switch and using the keys.
- (5) Close and re-lock the doors of the cabinet. Close the rear doors of the Stage 6 and 7 compartments, in the r.f. cabinets, and operate the FILAMENT INTERLOCK switches (SWH and SWQ) adjacent to the lower door. Close and lock the rear doors of the r.f. cabinets. Return keys to key panel and close H.T. EARTHING switch and H.T. INTERLOCK switch.
- (6) Press the START button, SWC. The start relay ST will close and the fan start. As the air pressure builds up, the air interlock switch will close and energize the filament contactor FC, which will energize the delay relay FD. (For Air Interlock Switch setting up see Section 11.9.) 30 seconds after FD has operated FF will operate and the FILS lamp (LP2) light. After a further 5 seconds the auxiliary h.t. relay LA will 'make' and the AUX H.T. lamp (LP3) light (in HS71/1 the fan on the R.H. R.C.U. should start when the FILS lamp lights).
- (7) Adjustment of Air Pressure Switch (HS71/1 only). Remove the sealing screws from the nozzles in Stage 6, one at the top of the valve compartment and one at the bottom of the coil unit. Connect a 'U' tube water gauge across these two nozzles. Take the cover off the air switch SWU. Adjust the spring pressure on the air switch by means of the knurled screw till the switch just operates at 1.2 in W.G. A convenient method of controlling air pressure is by partially blocking the air intake filter. Check that the switch opens when the pressure has fallen to not less than 0.8 in W.G.
- (8) When satisfied that the above sequence has occurred, press the H.T. ON button SWE. The main h.t. contactor MC will 'make' and the h.t. lamp (LP4) light (in HS71/1 MC will energize via ILR). In the aux. h.t. contactor control circuit are interlock switches associated with the STAGE 4 TUNE control and the ST.6 OUTPUT TUNE control, the STAGE 5 H.T. INTERLOCK switch on the front of the R.F. CABINET, and the r.f. cabinet rear door switches. Check that the auxiliary h.t. relay LA and the main h.t. contactor MC immediately de-energize and the associated lamps (LP3 and LP4) go out when either of the tuning controls are moved sufficiently to operate their associated interlocks (see Section 4.5.2 and 4.6.2 for details) and when the STAGE 5 H.T. INTERLOCK switch is set to SAFE, thus proving the operation of each associated interlock. After checking

each interlock, relay LA should automatically operate again and LP3 should light when the interlock is reclosed. Reset the main h.t., pressing the H.T. ON switch SWE.

- (9) Set the FREQUENCY selector switch, SWL, on the control panel, to each of its six positions in turn. At each setting check that the appropriate indicator lamp lights. This will prove the operation of the 'Ledex' switch in the Mixer Unit.
- (10) Press the H.T. OFF & RESET button. The main h.t. contactor MC (and ILR in HS71/1) will de-energize and the h.t. lamp extinguish. Press the STOP button and the remainder of the relays will de-energize and all the lights, except the 50V d.c. indicator and frequency lamp will be extinguished.

8.3 CHECKING FILAMENT SUPPLIES

8.3.1 Stage 7 Filament

Replace fuses FS14 and FS15 (6A) then close and lock the cubicle door and replace the key in the control panel. Close the lower door of Stages 6 and 7 valve compartment and the associated door switches.

Set the FIL VOLTMETER SWITCH on the front of the L.H. r.f. cubicle to the ST.7 filament position (12.6V). Turn the Stage 7 filament control on the front of the rectifier cubicle fully anticlockwise. Turn the MAINS ISOLATOR to CONNECTED.

Press the START button and note the reading on the voltmeter. It should show a reduced reading at first and then after 30 seconds, when relay FF operates, rise to full value.

Adjust the Stage 7 filament control until the indicated voltage is approximately 12.6V a.c.

Connect the external voltmeter to the filament pins on one of the Stage 7 valves.

Readjust the STAGE 7 FILS control for 12.6V a.c. on this meter.

The slightly higher reading on the filament voltmeter on the front panel should now be noted and when setting Stage 7 filament this reading should be used. Disconnect the external voltmeter.

8.3.2 Stages 5, 6 and Rectifier Filaments

- (1) Switch off and connect the external voltmeter across the secondary terminals of one of the main h.t. filament-transformers, and secure the meter in a position in which it can be seen through the rear window of the rectifier cabinet, when the door is shut. Insert fuses FS10, 11 and 12 (4A).
- (2) Set the STAGE 5, 6 and RECT FILS control on the front of the R.H. rectifier cubicle fully anticlockwise.
- (3) Set the FIL VOLTMETER SWITCH in the ST.5 position to indicate Stage 5 filament voltage on the FILAMENT VOLTMETER.

- (4) Note the reading of Stage 5 filament voltage on the meter, it should be 5 volts, if not, adjust the preset resistors R8, R9 and R10, or the secondary taps on TR4.
- (5) Repeat (3) but set to ST.6.
- (6) Note the reading of Stage 6 filament voltage on the meter, it should be 12.6 volts, if not, adjust the preset resistors R22, R23 and R24 or the secondary taps on TR17.
- (7) Adjustments carried out in (4) and (6) should be checked against each other and against the filament voltage shown on the test meter, which should be maintained at the correct voltage by adjustment of the STAGE 5, 6 and RECT FILS control.
- (8) Adjustment is correct when all filament voltages are correct with the front panel control at approximately mid-setting; this allows adequate adjustment of both supplies for variations of mains voltage. Switch off and remove the external voltmeter.

8.3.3 Auxiliary Filaments

This is a preset adjustment for which no panel control is necessary.

Insert fuse FS5(2A) and set the FIL VOLTMETER SWITCH to AUX.

6.3V a.c.

Turn MAINS ISOLATOR to CONNECTED and press the START button. The meter should read 6.3V a.c. If not, the preset resistor R2 must be adjusted. To do this it is necessary to switch off and open the rectifier unit door to enable the meter panel to be hinged forward, so allowing access to the resistor.

8.4 CHECKING BIAS AND AUXILIARY H.T. SUPPLIES

With the transmitter switched off replace the fuses FS6 and FS17.

Close the door and the main isolator and the earthing and interlock switches press the START button. Wait for the filaments and auxiliary h.t. lamps to light.

Check the bias voltages on the AUX VOLTMETER on the r.f. cabinet; they should be approximately as follows:- Mixer Suppressor, 110V: Stage 4, 25V: Stage 5, 110V: Stage 6, 110V: Stages 2 & 3, 105V: Stage 7 bias, 110V.

Any major discrepancy in bias value should be investigated and corrected; the exact bias levels of each stage must be adjusted after application of h.t. - see Section 8.6.

Switch off the transmitter and replace fuse FS16. Switch on again and check the MIXER H.T. and AUX H.T. voltage on the AUX VOLTMETER. They should be :- 280V and 450V. The 450V h.t. may be high if the static feed on Stage 4 has not been adjusted (see Section 8.6 (viii)).

8.5 CHECKING THE MAIN H.T. RECTIFIER OUTPUT

With the transmitter switched off replace fuses FS7, FS8 and FS9*. Close the doors, the MAIN ISOLATOR, the H.T. EARTHING and the H.T. INTERLOCK switches. Press the START button and check that the filament and auxiliary h.t. indicator lamps light. Press the H.T. ON button. Check that the h.t. indicator lamp lights. The H.T. VOLTS meter on the metal panel at the top of the rectifier cabinet should show 4 kV. Set the H.T. VOLTS low/full selector switch to LOW. The voltmeter should now show a lower reading, depending upon the load on the rectifier. With only static feeds on the Stage 6 and Stage 7 valves it will be approximately 3.3 kV.

8.6 ADJUSTING THE BIAS VOLTAGES

The bias levels (except mixer suppressor bias) are set up by adjusting the static feeds (i.e. with no r.f. drive) to each stage, and will require adjustment after valve replacement if optimum performance is to be obtained.

The bias voltages for the mixer and Stages 4-7 are adjusted by variable resistors; those for Stages 2 and 3 in the Mixer Unit are accessible when the unit is pulled forward on its runners, but those for Stages 4-7 are mounted on the meter panel at the front of the Control, Power Supply cabinet, and can be adjusted without switching the transmitter off.

- (i) Close the doors, the MAIN ISOLATOR, the H.T. EARTHING and the H.T. INTERLOCK switches. Press the START button and check that the FILS and AUX H.T. lamps light. Press the H.T. ON button and check that the h.t. indicator lamp lights.
- (ii) Withdraw the Mixer Unit on its runners for access to the chassis controls.
- (iii) Set the HG METERING switch to MIXER.
- (iv) Set the MIXER & MONITOR METERING switch to V10, 100 mA (the meter now indicates Stage 2 cathode current). Adjust the potentiometer marked AMPLIFIER (Stage 2 bias) on the chassis rear for a reading of 40 mA on the meter.
- (v) Set the MIXER & MONITOR METERING switch to V11, 100 mA (the meter now indicates Stage 3 cathode current). Adjust the potentiometer marked RV3 (Stage 3 bias) on the chassis front for a reading of 25 mA on the meter.
- (vi) Push the Mixer Unit back into the cabinet.
- (vii) Set the AUXILIARY VOLTMETER switch on the front of the r.f. cabinet to read MIXER SUP. BIAS; it should be approximately 105V.
- (viii) Set the AUXILIARY VOLTMETER switch to read STAGE 4 BIAS, and check the Stage 4 cathode current; it should be 90 mA when the bias reading is 20-25V. If necessary, adjust the Stage 4 bias potentiometer RV11, on the meter panel at the front of the Control, Power Supply cabinet, to obtain a reading of 90 mA. Check that

* In HS71/1, close CB1

the stage h.t. is approximately 450V. It may be necessary to alter the transformer taps (TR6) to obtain the correct voltage.

- (ix) Set the AUXILIARY VOLTMETER switch to read STAGE 5 BIAS and check the Stage 5 cathode current; it should be 60 mA when the bias reading is 70-80V (HS71) or 90-100V (HS71A). If necessary adjust the Stage 5 bias potentiometer RV12 on the meter panel at the front of the Control, Power Supply cabinet, to obtain a reading of 60 mA. The cathode current should be set in the range 0.2 to 0.32A when using a Type ACT70 valve.
- (x) Set the AUXILIARY VOLTMETER switch to read STAGE 6 BIAS, and check the Stage 6 cathode current; it should be 0.32A when the bias reading is 100-110V. If necessary, adjust the Stage 6 bias potentiometer RV13 on the meter panel at the front of the Control, Power Supply cabinet, to obtain a reading of 0.32A.
- (xi) Set the AUXILIARY VOLTMETER switch to read STAGE 7 BIAS and check the Stage 7 cathode current; it should be 0.7A with a Stage 7 grid bias voltage of 100-110V; if necessary adjust the Stage 7 bias potentiometer RV14 on the meter panel at the front of the Control, Power Supply cabinet, to obtain a reading of 0.7A.

8.7 SETTING UP THE OVERLOAD RELAYS

8.7.1 Method 1

This may be done in each case, Stage 5, Stage 6 and Stage 7 by connecting the valve anode supply line to earth via a variable resistance and a d.c. supply, the transmitter doors being opened and the h.t. lines being then earthed. The variable resistance is adjusted to give the required relay tripping current and the relay adjusted to just operate.

Stage 5: Use approx. 18 volts and variable resistance of 20 ohms; trip current 270 mA. Adjust the relay by means of the armature tensioning spring control.

Stage 6: Use approx. 18 volts and resistance of 10 ohms; trip current 1.0 amps. Adjust the relay by the resistor (RV6) on the relay panel, the tensioning spring being set to the middle of its adjustment.

Stage 7: Use approx. 18 volts and resistance of 2 ohms; trip current 4.0 amps. Adjust the relay by the resistor (RV10) in the relay panel, the tensioning spring being set to the middle of its adjustment.

8.7.2 Method 2

The overload relays are set up when the transmitter has been tuned and is operating on full power. The instructions are contained in this section for the sake of completeness.

The relays are situated in the rectifier cabinet and are not accessible when the power supply is on. Accordingly, adjustments must be made progressively. It will be seen that there is a small red flag associated with each relay contact assembly; this falls into a downward

position when the relay operates to provide a rapid indication of which relay has tripped when a fault occurs. Before resuming operation after a trip, the flag must be returned to its normal position.

(a) Stage 5 Relay OD

Apply r.f. drive and set the cathode current of Stage 5 to 280 mA, detune the stage if necessary. Take care to restrict the time duration of this detune period, as excessive temperature rise in the valves may take place. It is also advisable to keep a check on Stage 6 feed, as with an excessive feed due to detuning Stage 5, Stage 6 trip relay will operate the overload relay.

If the relay trips before the current reaches 280 mA, switch off, remove the relay cover and tighten up the tensioning spring, then switch on again and carry on increasing the cathode current. Repeat until the relay just trips at 280 mA.

If the relay trips after the current reaches 280 mA, switch off and slacken off the tensioning spring; then switch on and slowly increase the current again. Repeat until the relay just trips at 280 mA.

(b) Stage 6 Relay OE

Setting up this relay is done by adjustment of its tensioning spring and of shunt resistance, RV6.

Set RV6 to about mid-way. Switch on and adjust Stage 6 cathode current to 1.0 amp. If it is necessary to detune the stage to obtain this current, it must be done only for very short periods as for Stage 5.

If the relay trips at less than 1.0 amp, switch off and turn RV6 clockwise; switch on again and carry on increasing the current. Repeat until the relay just trips at 1.0 amp. If this adjustment cannot be obtained, set RV6 to its mid-position and tighten up the relay tension spring. Carry on checking and adjusting the spring until the relay just trips at 1.0 amp.

If the relay does not trip at 1.0 amp, reduce the current, switch off and turn RV6 a little anticlockwise; switch on again and increase the cathode current again. Repeat until the relay just trips at 1.0 amp. In this case, if the adjustment of RV6 does not bring the relay to the required operating point, set it to mid-position and slacken off the relay tensioning spring.

(c) Stage 7 Relay OF

Setting up this relay is done in a similar manner to the Stage 6 relay but using RV10 in place of RV6 and setting it to trip at 3.8 to 4 amps.

8.8 REMOTE CONTROL

NOTE: *The provision for Remote Control has been removed in order to provide additional auto-alarm facilities. It may be restored to its pre-modification state by reference to A.P.2922E, Vol.2.*

Connect the Remote Control Unit as shown on the installation diagram (switch between TB6(7) and TB6(12)) and set the LOCAL/REMOTE control switch to REMOTE. Setting the remote switch to ON should bring all the contactors in sequence up to full operating condition.

9 TUNING*

When the transmitter is first installed and after being closed down for maintenance, it should be checked as described in Section 8 before being tuned. Tuning may conveniently be carried out using a lamp lead, though this is not essential if an aerial is available.

Test Equipment required: Spectrum Analyser OA1094 (AP.103540)
Artificial load for transmitter (600Ω)

NOTE: *When the transmitter is driven by a Type HD61B Frequency Shift Duplex Equipment only Section 9.3 is applicable.*

9.1 I.S.B. OPERATION

9.1.1 Calculation of Harmonic Generator and Crystal Drive Frequency

For any radiated frequency in the range 4-27.5 Mc/s the frequency multiplication required in the harmonic generator stages of the Mixer Unit and the crystal oscillator frequency to be used is calculated as follows:-

fRAD = Final radiated frequency in Mc/s.

fx = Crystal oscillator frequency in Mc/s.

m = Frequency multiplication in harmonic generator stages of the Mixer Unit.

3.1 = 3.1 Mc/s keyed signal to mixer from Keying Unit.

When fRAD is less than 10 Mc/s

m = 2

$$\text{fRAD} = 2\text{fx} - 3.1 \text{ Mc/s or: } \text{fx} = \frac{\text{fRAD} + 3.1}{2} \text{ Mc/s}$$

When fRAD is between 10 and 17 Mc/s

m = 2

$$\text{fRAD} = 2\text{fx} + 3.1 \text{ Mc/s or: } \text{fx} = \frac{\text{fRAD} - 3.1}{2} \text{ Mc/s}$$

When fRAD is greater than 17 Mc/s

m = 4

$$\text{fRAD} = 4\text{fx} + 3.1 \text{ Mc/s or: } \text{fx} = \frac{\text{fRAD} - 3.1}{4} \text{ Mc/s}$$

An explanation of the manner of operation of the harmonic generator and the reasons underlying the selection of the primary crystal frequencies appears in Section 6.2.2.

9.1.2 Tuning the Harmonic Generator

Switch the auxiliary h.t. on as described in Section 10.

* HS71 and HS71A only. For HS71/1 see Supp.4

Set the frequency selector switch on the control panel to select the crystal oscillator it is desired to use and apply the appropriate primary drive frequency calculated in Section 9.1.1.

Set the fHG Mc/s. switch (harmonic generator range) to the range in which the required harmonic generator frequency (fHG), calculated in Section 9.1.1 lies.

Set the HG METERING switch to the 'MIXER' position and set the MIXER & MONITOR METERING switch to the V7/V8 position (mixer cathode current).

Adjust the HG TUNE control for maximum reading on the meter, see calibration curves Fig. 2^A for the approximate scale setting.

9.1.3 Tuning the Mixer and Stages 1, 2 and 3

Check that the ISB drive equipment is operating satisfactorily, then apply the two test tones, each adjusted to 6 dB down relative to $\frac{1}{4}$ watt.

Set fRAD Mc/s (the mixer range-switch) to the range in which the required radiated frequency lies.

Pull out the Mixer Unit on its runners.

Set the mixer suppressor bias, MANUAL/REMOTE switch, SWF to MANUAL.

Adjust the MIXER TUNE control for maximum reading, on the STAGE 4 GRID PEAK VOLTS meter, if necessary, adjust the MANUAL control (mixer level RV5), to obtain a reading. Check the scale reading of the 'MIXER TUNE' against the calibration curves Fig.2 to ensure that the desired radiated frequency has been obtained, as it will in some cases be possible to tune the mixer to fHG - i.f., fHG + i.f., and to fHG itself, depending on the range.

9.1.3A Setting-Up the DRIVE LEVEL Control

Where the transmitter has been modified to have a DRIVE LEVEL control on the front panel it should now be set-up in accordance with the instructions in Supplement 3, Section 4.

9.1.4 Tuning Stage 4

Refer to the calibration charts Fig.3 and set the STAGE 4 TUNE control to its approximate position for the required radiated frequency. On some frequencies, the tuning point may be obtained at two settings of the Stage 4 turret, either setting will do.

Set the MANUAL control (mixer level RV5), to give a reading of about 2 volts on the STAGE 4 GRID PEAK VOLTS meter.

Adjust the STAGE 4 TUNE control for maximum reading on the STAGE 5 GRID PEAK VOLTS meter.

9.1.5 Tuning Stage 5

Refer to the calibration charts Fig.3 and set Stages 5, 6 and 7 tuning controls to their approximate positions for the required radiated frequency. Set the Stage 6 and feeder coupling controls to minimum (fully anticlockwise). The Stage 7 input tune control should be set to the position shown on the calibration chart Fig.4 and will not normally be readjusted.

Set the RANGE switch and the ST.7 & OUTPUT RANGE SWITCH to the range in which the required radiated frequency lies; these are obtained from the calibration curves.

Reduce the Stage 4 grid volts i.e. mixer output level, to 0.V, by means of MANUAL control and press the HT ON button.

Increase the level to give Stage 5 cathode current of about 100 mA. (Indicated on the STAGE 5 CATHODE CURRENT meter on the 4th and 5th RF Unit).

Adjust the STAGE 5 TUNE control for minimum Stage 5 cathode current, keeping the MANUAL control adjusted so that Stage 6 cathode current does not rise above 0.6A and the Stage 6 grid current does not rise above 100 mA.

If Stage 5 is unstable, adjust the neutralising control for stability and carry on tuning the transmitter. Neutralise fully as described in Section 9.1.11 when the loading of the final stage is approximately correct as described in Section 9.1.8.

9.1.6 Tuning Stage 6

Adjust the STAGE 6 TUNE control for minimum cathode current, keeping the stage grid current below 100 mA.

Increase the STAGE 6 COUPLING until grid current just begins to fall. Tune STAGE 6 OUTPUT TUNE for maximum cathode current on Stage 6 or to maximum drive to Stage 7, keeping the Stage 7 grid current below 50 mA and Stage 7 cathode current below 2A.

Re-check the adjustment of the tuning controls of the preceding stages (Sections 9.1.3 to 9.1.5).

Adjust STAGE 6 OUTPUT TUNE control for maximum Stage 6 cathode current. Stage 6 coupling control should be adjusted to provide just enough drive to give an indication of maximum Stage 6 cathode current when the output circuit is tuned. If the coupling is too great the anode and output circuit tunes will react on each other.

Re-check Stage 5 tuning for minimum Stage 5 cathode current.

9.1.7 Tuning Stage 7

Adjust STAGE 7 ANODE TUNE control for minimum cathode current, keeping the stage grid current below 200 mA.

Adjust STAGE 6 COUPLING to give about 200 mA grid current on Stage 7.

Increase FEEDER COUPLING until the Stage 7 grid current just begins to fall and a reading is obtained on the FEEDER INDICATOR. Tune the output circuit (FEEDER TUNE) for maximum cathode current on Stage 7 or for maximum FEEDER INDICATOR reading. Re-adjust STAGE 7 ANODE TUNE control for minimum cathode current. Increase the stage coupling until the FEEDER INDICATOR reading is about maximum.

9.1.8 Final Tuning

Reduce the STAGE 6 COUPLING and adjust the MANUAL control RV5, until Stage 6 grid current is about 100 mA and Stage 7 grid current about 50 mA.

Retune STAGE 6 OUTPUT TUNE and adjust STAGE 6 TUNE. Repeat these two adjustments until both tuning points are coincident. Increase STAGE 6 COUPLING until a maximum Stage 7 grid current is obtained, keeping this below 200 mA with the MANUAL control. Retune STAGE 6 TUNE and STAGE 5 TUNE.

Increase the MANUAL control and adjust FEEDER COUPLING until Stage 7 grid current is 250-300 mA and Stage 7 cathode current is 2.6-2.7A retuning STAGE 7 ANODE TUNE for each adjustment of FEEDER COUPLING.

Increase the STAGE 6 COUPLING to give a Stage 6 grid current of between 30 mA and 45 mA and a Stage 6 cathode current of between 0.65 and 0.8A, readjusting the level control for the Stage 7 cathode current derived above and retuning STAGE 6 TUNE for each adjustment of STAGE 6 COUPLING.

Re-check the settings of the anode tuning controls of all stages and finally neutralise Stage 5 if necessary as described in Section 9.1.11.

Check all meter readings for general agreement with those shown on the chart of typical power figures Fig.5, or the Test Report supplied with the transmitter.

9.1.9 Checking Distortion

Connect the U-link on the mixer monitor frequency changer to the ST. 7 monitoring point and the U-link on Stage 7 to the FEEDER monitoring point.

Check the distortion on the Spectrum Analyser or the monitor receiver in the ISB drive rack, as explained in the relevant handbook.

Adjust the Stage 5 FEEDBACK potentiometer for minimum distortion indicated on the monitoring equipment. If the distortion is higher than the required figure, it may be necessary to adjust the STAGE 6 COUPLING slightly. As a general rule, for best results, coupling should be slightly greater than optimum. After any adjustment of coupling, readjust the FEEDBACK potentiometer and MANUAL control.

When tuning up to the first time, it will be found helpful to use a CRO to display the RF waveform, when the effects of over coupling and under coupling will be clearly seen. If the coupling is too tight there will be a tendency for the waveform to flatten; increasing the coupling overcomes this tendency but of course Stage 6 loss increases, so that it should not be overcoupled more than necessary.

9.1.10 Setting-up Mixer Preset Level Controls

Having set a working frequency the mixer bias MANUAL/REMOTE switch SWF, (see Section 6.2.3), may be set to REMOTE and the preset level control for the frequency range in use may be adjusted to obtain first output for $\frac{1}{4}$ W PEP input. If this is done on each range when a working frequency is set up on that range, the correct level will then be automatically selected for each of the six positions on the frequency selector switch.

Finally, log all meter and scale readings for future reference.

9.1.11 Neutralizing Stage 5

Neutralising should be carried out when the set is first tuned and subsequently should only be necessary after changing valves. It should be carried out at 20 Mc/s, or alternatively at the highest frequency normally used, up to 22 Mc/s.

Either of two methods may be used.

- (a) Adjust STAGE 5 TUNE-control for minimum cathode current.

With the i.f. level reduced, detune on either side of the tuning point and note Stage 6 grid current. If Stage 5 is properly neutralised, the dip in cathode current will coincide with a peak of Stage 6 grid current. If there is an increase of Stage 6 grid current on one side of the tuning point, rotate the Stage 5 NEUTRALISING control a little in the same direction as the tuning control was turned to give the rise. Retune Stage 4. Swing the tuning control through the tuning point again and note cathode current and Stage 6 grid current. Continue adjusting the NEUTRALISING control and checking the currents until the dip in Stage 5 cathode current and the rise in Stage 6 grid current exactly coincide.

NOTE: *It is important to retune STAGE 4 TUNE after each adjustment of the NEUTRALIZING control.*

- (b) Completely detune Stage 5. Set the MANUAL/REMOTE switch to MANUAL.

Adjust the MANUAL control to give approximately 100 mA Stage 5 cathode current. Tune through minimum cathode current then detune completely on the other side of the tuning point and note the current.

Adjust the NEUTRALISING control until the cathode current reading is the same when the stage is completely detuned on either side of the tuning point, readjusting Stage 4 tune as necessary.

9.2 CW AND FSK OPERATION

Proceed as for ISB operation up to Section 9.1.6 except that in Section 9.1.3 apply the i.f. drive from the CW/FSK drive unit, at 0.25 watt.

For final adjustment of the loading of Stage 6 and 7 (Section 9.1.6) reduce Feeder and St.6 coupling to give grid and cathode currents as follows:-

HS.71 Stage 6 - grid current 45-55 mA, cathode current 0.6-0.75A.

HS.71A Stage 6 - grid current 45-55 mA, cathode current 0.55-0.75A.

HS.71 Stage 7 - grid current 600 mA cathode current 3.2-3.4 A.

HS.71A Stage 7 - grid current 500 mA, cathode current 3.2-3.3A.

It will be observed that all other figures also will be correspondingly higher than on ISB operation, as shown on the chart of typical figures.

Ensure that: $St.7Ic + St.5Ia - (St.6Ig + St.7Ig) \neq 3.75A$

Finally, log all meter and scale readings for future reference.

9.2A DSB OPERATION

Apply the DSB carrier at the intermediate frequency, tune the transmitter as described in Section 9.1 except that the drive and coupling controls should be adjusted with the carrier only applied to give Stage 7 grid and cathode currents 150 mA and 2.3A respectively. Stage 6 grid and cathode currents should be approx. 20 mA and 0.55A respectively.

9.3 TUNING WHEN USING EXTERNAL DRIVE

9.3.1 General

After setting-up the external drive unit as described in the relevant handbook set the following transmitter switch and link to the positions shown:

Switch/link	Position
AUTO/MANUAL Switch	MANUAL
EXT. DRIVE/ST.4 INPUT/MIXER link.	EXT.DRIVE to ST.4 INPUT.

NOTE: *Figures given in this section are for ISB operation for CW and FSK use the figures given in Section 9.2.*

9.3.2 Tuning Stage 4

Refer to the calibration chart, Fig.3 and set the STAGE 4 TUNE control to its approximate position for the required radiated frequency. On some frequencies, the tuning point may be obtained at two settings of the Stage 4 turret, select the point which does not trip the AUX.HT when the later stages are tuned.

Set the EXT.DRIVE LEVEL* control (RV7) to give a reading of about 2 volts on the STAGE 4 GRID PEAK VOLTS meter.

Adjust STAGE 4 TUNE control for maximum reading on the STAGE 5 GRID PEAK VOLTS meter.

9.3.3 Tuning Stage 5

Refer to the calibration chart, Fig.3 and 4 and set Stages 5,6 and 7 tuning controls to their approximate positions for the required radiated frequency. Set the STAGE 6 COUPLING and FEEDER COUPLING controls to minimum (fully anticlockwise). The STAGE 7 INPUT TUNE control should be set to the position shown on the calibration chart and will not normally be readjusted.

Set the RANGE switch and the ST.7 & OUTPUT RANGE SWITCH to the range in which the required radiated frequency lies.

Reduce the stage 4 grid volts i.e. External drive level, to 0V by means of EXT.DRIVE LEVEL* control and switch on the main HT.

x DRIVE LEVEL control in HS.71A

Increase the level to give Stage 5 cathode current of about 100 mA.

Adjust the STAGE 5 TUNE control for minimum Stage 5 cathode current, keeping the level control adjusted so that stage 6 cathode current does not rise above 0.6A and the grid current does not rise above 100 mA.

If stage 5 is unstable, adjust the NEUTRALISING control for stability and carry on tuning the transmitter. Neutralise fully as described in Section 9.1.11 when the loading of the final stage is approximately correct as described in Section 9.3.6.

9.3.4 Tuning Stage 6

Adjust the STAGE 6 TUNE control for minimum cathode current, keeping the stage grid current below 100 mA.

Increase the STAGE 6 COUPLING until the stage grid current just begins to fall. Tune STAGE 6 OUTPUT TUNE for maximum cathode on Stage 6 or to maximum drive to Stage 7, keeping the Stage 7 grid current below 50 mA and Stage 7 cathode current below 2A.

Re-check the adjustment of the tuning controls of the preceding stages (Sections 9.3.2 and 9.3.3).

Adjust STAGE 6 OUTPUT TUNE control for maximum Stage 6 cathode current. Stage 6 coupling control should be adjusted to provide just enough device to give an indication of maximum Stage 6 cathode current when the output circuit is tuned. If the coupling is too great the anode and output circuit tunes will react on each other.

Re-check Stage 5 tuning for minimum Stage 5 cathode current.

9.3.5 Tuning Stage 7

Adjust STAGE 7 TUNE control for minimum cathode current, keeping the Stage grid current below 200 mA.

Adjust STAGE 6 COUPLING to give about 200 mA grid current on Stage 7

Increase FEEDER COUPLING until the Stage 7 grid current just begins to fall and a reading is obtained on the Feeder Indicator. Tune the output circuit (FEEDER TUNE) for maximum cathode current on Stage 7 or for maximum FEEDER INDICATOR reading. Readjust STAGE 7 TUNE control for minimum cathode current. Increase the stage coupling until the feeder indicator reading is about maximum.

9.3.6 Final Tuning

Reduce the STAGE 6 COUPLING and adjust the EXT.DRIVE LEVEL* control until Stage 6 grid current is about 100 mA and Stage 7 grid current about 50 mA. | AL2

Re-tune STAGE 6 OUTPUT TUNE and adjust STAGE 6 TUNE. Repeat these two adjustments until both tuning points are coincident. Increase Stage 6 coupling until a maximum Stage 7 grid current is obtained, keeping this below 200 mA with the level control. Re-tune Stage 6 and Stage 5.

Increase the EXT.DRIVE LEVEL* control and adjust FEEDER COUPLING until Stage 7 grid current is 250-300 mA and Stage 7 cathode current is 2.6-2.8A retuning STAGE 7 ANODE TUNE for each adjustment of FEEDER COUPLING. | AL2

Increase the STAGE 6 COUPLING to give a Stage 6 grid current of between 30 mA and 45 mA and a Stage 6 cathode current of between 0.65 and 0.8A, readjusting the EXT.DRIVE LEVEL control for the Stage 7 cathode current derived above and retuning STAGE 6 TUNE for each adjustment of STAGE 6 COUPLING.

Re-check the settings of the anode tuning controls of all stages and finally neutralise Stage 5 if necessary as described in Section 9.1.11.

Check all meter readings for general agreement with those shown on the chart of typical power figures Fig.5 or the Test Report supplied with the transmitter.

10 OPERATING INSTRUCTIONS

This section contains 'switching' instructions only. It is assumed that the transmitter has been set up and tuned as described in Sections 8 and 9 and is in all respects ready for use and that the drive equipment is correctly set-up and is switched ON.

10.1 STARTING-UP INSTRUCTIONS

1. Close and lock the front and rear doors of the Rectifier Cabinets and the rear door of the RF cabinets. Remove the keys from the door locks and insert in control panel.
2. Close the external wall isolator switch.
3. Check that the various control switches are set to their correct positions as follows:-

AUTO/MANUAL switch AUTO (when using external drive to MANUAL)

LOCAL/REMOTE switch to LOCAL.

HT VOLTS selector switch to FULL.

* DRIVE LEVEL control in HS.71A.

The primary oscillator equipment may be set up to provide crystal drive frequencies for up to six different radiated frequencies. The crystal oscillators are selected by operation of the FREQUENCY selector switch, which must now be set to the oscillator required.

4. TURN the MAINS ISOLATOR, the H.T. EARTHING and the H.T. INTERLOCK switches to CONNECTED, OFF and CLOSED respectively.
5. Check the voltage of each phase of the a.c. supply.
6. (a) Check that the 50V d.c. indicator lamp and one of the FREQUENCY indicator lamps have lit. (When on MANUAL only 50V lamp will light.)
(b) Press the START button.
(c) The fan should start.
(d) Check that after 30 seconds approx. the FILS indicator lamp lights, followed by the AUX H.T. lamp.
(e) Check the filament voltages on the voltmeter on the r.f. cabinet against the figures obtained in Sections 7, 8 and 9 and adjust as necessary by the filament controls on the Rectifier Cabinet.
(f) Check the bias and auxiliary h.t. supplies on the voltmeter on the r.f. cabinet.
7. (a) Press the H.T. ON button.
(b) Check that the h.t. indicator lamp lights. Check the reading on the h.t. voltmeter on the meter panel.
8. (a) Apply the i.f. drive input.
(b) Check that the voltage and current readings of each stage are in accordance with the figures obtained when the transmitter was tuned.

10.2 OVERLOAD RESET

If the overload relays trip, the main h.t. contactor will be de-energized and h.t. indicator lamp will be extinguished.

Unless there is an apparent defect main h.t. may be restored by pressing the H.T. OFF & RESET button and then the H.T. ON button.

Check the meter readings.

If the overload relays trip again on reapplication of h.t., the cause must be investigated.

10.3 CLOSING DOWN INSTRUCTIONS

(a) Temporary Stoppage

Transfer any incoming traffic.

Press the H.T. OFF & RESET switch - this will remove main h.t.

Press the STOP switch.

All circuits except the 50V supply unit will be de-energized.

(b) Complete Close Down

Transfer any incoming traffic.

Press the STOP button.

Turn off the H.T. INTERLOCK, the H.T. EARTHING and the MAINS ISOLATOR switches.

Finally, open the external wall a.c. supply switch. The transmitter is now completely disconnected from the mains.

11 MAINTENANCE

11.1 ROUTINE MAINTENANCE

11.1.1 Daily, when the Set is in use

- (a) Take a complete set of meter readings and check them against the readings noted when the transmitter was tuned.
- (b) Check the filament bias and h.t. meter readings.
- (c) Check the air filter and replace if dirty. Wash the dirty filter as detailed in Section 11.3.

11.1.2 Weekly

Check that the fan is running quietly and that there is no undue heating.

Check that the filament connections of the high power valves are tight. Reverse the filament connections of Stage 5 and 6 by means of the switches SWQ and SWK every week of service.

Blow out any dust which may have accumulated in the cubicles. Remove any dust from the envelopes of the high power valves with a soft rag moistened with white spirit. Cleaning must only be done when the valves are quite cold.

Check that the overload relays operate as described in the setting-up instructions, Section 8.7.

Check that the 'Ledex' switches operate when the frequency selector switch is operated.

Check the movement of the tuning controls. Points which may require attention are as follows:-

- (a) Coil contacts. These are made of silver with a small percentage of graphite. Neither the coil surface nor the contacts require a lubricant. The contact pressure, however, affects the torque required to move the coil and therefore the time for one revolution (see Section 11.2 for contact pressure adjustment).

(b) Gearboxes. These are lubricated with Aeroshell 11 grease.

NOTE: *The worm gearbox driving Stage 6 Output Tune is packed full of grease and should never require attention.*

(c) Switches and coil spindles. The ball contacts and their tracks should be lightly greased with Aeroshell 11. The bearings of Stage 6 Output unit switch are ball races and packed with grease. Similarly the chain sprocket bearings: these should never require treatment.

(d) Sintered bronze bearings. These should be lightly oiled using a high quality light machine oil such as CALTED 548 or VACULINE 'G'. It is very important that the minimum quantity of oil be used, especially where the bearings are supported on micalex plates. On no account should oil be allowed to fall onto these insulating plates.

(e) Guide rods and telescopic tubes. A light smear of Aeroshell 11 grease applied occasionally should suffice to maintain free movement.

(f) Starting torques. The following figures may be used as a guide to satisfactory operation of any of the driven components:

Control	Max. Starting Torque	Control	Max. Starting Torque
1. Stage 4 Tune	35 oz in	6. Output Coupling	120 oz in
2. Stage 5 Tune	80 oz in	7. Stage 7 Input	100 oz in
3. Range	350 oz in	8. Stage 7 Anode	120 oz in
4. Output Tune	40 oz in	9. Feeder Coupling	120 oz in
5. Stage 6 Anode	120 oz in	10. Feeder Tune	100 oz in
		11. Stage 7 Output Range	350 oz in

(g) Driving Chain to Range Switches. These should be cleaned and re-greased with Aeroshell 11 when examination reveals it is necessary. Grease should be used sparingly.

NOTE: *Access to the upper bearings of the tuning coils of Stages 6 and 7 and the lead screws of the coupling coils is obtained by removing a plug bolt in the top of the bearing housing. To gain access to Stage 6 lead screw bearing it is necessary to:-*

(1) *Remove the Output Tuning Unit of Stage 6.*

(2) *Take off the right-hand side plate and the small front panel, thus exposing to view the connectors between the coupling coil and the contact blocks. Remove these two strip connectors and the top plate can then be removed, exposing the plug bolt.*

To gain access to Stage 7 coupling bearing remove the feeder switch unit and the plug bolt will be found in the exposed well.

11.1.3 Quarterly

Check the functioning of the filament delay switch.

Examine the contactors and relays.

If the contacts of contactors require cleaning, this should be done with carbon tetrachloride or one of the patent cleaning fluids. If they are badly burnt it may be possible to restore the surfaces by careful filing with a smooth file and then burnishing, taking care to maintain the original shape of the contact. Abrasive paper should never be used.

Relay contacts may be cleaned with a cleaning fluid. If contacts are badly burnt, the whole relay should be replaced.

The bearings of the contactors should be oiled with one drop of thin oil. Over-oiling is worse than no oil at all. Under no circumstances should relays be oiled.

All the joints, knuckles and sliding surfaces of the mechanical interlock system should be oiled with a light machine oil. A drop or two should also be applied to the locks of the interlock system and the moving parts of the isolator. Occasional lubrication will make a big difference to the ease with which all these items operate.

When the suction fan motor has two grease cups, these should be filled with a small amount of high grade grease. This should be injected every 1-3 months, depending on how much the transmitter is used.

When the suction fan motor has two oiling holes, high grade oil (SAE30) should be used to maintain the oil level at the level indicated on the case.

Check the contact pressures as described in Section 11.2.

The sliding surfaces of the withdrawable units should be lightly lubricated with oil or grease, according to the surfaces involved.

See also Supplement 4, Sect. 11.4 for R.C.U. Fan Maintenance.

11.1.4 Yearly

Check over all terminal connections.

Check all clamped and/or flexible cables for signs of wear.

Check the insulation of the power circuits.

Verify that all cubicles and other pieces of equipment are properly earthed, and that the earth connections are sound, with special attention to low level devices.

Lightly oil lock mechanism on the door switches.

11.2 STAGES 5, 6 AND 7 COIL TUNING CONTACTS

Stage 6 and Stage 7

Each contact should have a pressure of 900 gms at least and the sum of the pressures of top (and bottom) pair should be not less than 2250 gms. The guide rod contact pressure should be not less than 675 gms each.

If all the balls do not make contact at the correct pressure, they should be adjusted as follows:-

NOTE: *Reference numbers quoted in the following adjustments will be found on Figs.4 or 12.*

1. Wind the Spring Contact Assembly (Ref.84) to the top of the coil.
2. Adjust the pressure on the ball contacts by slackening the special nuts holding the top of the rod in position in the slot in the mounting plate, setting the rod nearer the coil for greater pressure and away from the coil for less pressure. Tighten the special nuts.
3. Wind the Spring Contact Assembly to the bottom of the coil.
4. Adjust the pressure on the ball contacts by slackening the special nuts holding the bottom of the rod in position, and adjusting the rods position in the same way as for 2 above. Tighten the special nuts.
5. Repeat 1-4 as often as necessary until the Spring Contact Assembly exerts a uniform pressure along the whole length of the coil.

A method of checking the pressure of the ball contacts on the coil is to make a loop of wire around a contact and hook a spring balance through the loop. Pull the contact away from the coil at its point of contact by means of the ring at the end of the spring balance, and check the spring balance reading at the 'breaking' point. Check that the anode coil and ball contacts are clean. If not, clean them with a soft cloth.

Stage 5

The pressure of the contacts on the coil should be not less than 200 gms and the pressure of the contacts on the rod above the coil should be not less than 450 gms.

NOTE: *There is no adjustment of Stage 5 contacts.*

11.3 ALIGNMENT OF THE MIXER UNIT

Circuit Diagram: Figs.18 & 19 (HS71/1: Figs.18, 19A)

Component Layout: Fig.13 (HS71/1: Figs.13, 13B)

Calibration Curves: Fig.2

The following list of Test Equipment may be varied according to customer's requirements.

Test Equipment required

- 1 Two-tone test Generator TF1143 (AP.103480 and 103481)
- 1 Spectrum Analyser OA1094 (AP.103540)
- 1 Signal Generator TF144G or CT218
- (an7) 1 Valve Voltmeter TF428 or CT~~24~~4 (to be connected by 2 yards of coaxial and terminated with a 220 Ω resistor and a 33 pF capacitor).
- 2 Avometer 40, 7 or 8 or AP.47A
- 1 Insulation test set
- 1 Test rig for mixer panel (optional)
- 1 Artificial load for transmitter (600 Ω or 50 Ω)

Also required crystal oscillator panel such as HD61B or HD21.

The drawing references against component identities throughout this section refer to the component layout drawing.

The Mixer Unit is set up at the factory and should not require alignment when the transmitter is first installed.

an7 The following section describes the complete procedure for alignment but it should be noted that sub-sections 11.3.3 and 11.3.5, covering balancing and final alignment, should be sufficient for normal purposes.

The alignment is to be carried out in a screened room on multi-transmitter stations to eliminate effects of r.f. fields on the test equipment using the test harness described below.

The test rig for the mixer panel is a metal stand with an angle iron framework top, pivoted in the centre; it has guides and clips to hold the mixer unit firmly when placed in the rig. The rig allows the mixer panel to be turned over and locked in any convenient position whilst aligning it.

Around the test rig the test equipment should be placed at a convenient level for the person aligning the units. The unit requires a power supply which gives outputs of 280V stabilized, 400V d.c., 6.3V a.c. and -150V d.c. (normally the power unit is supplied with the test rig).

11.3.1 Preliminary Alignment of the Harmonic Generator

- (i) Withdraw the Mixer Unit on its runners and remove its baseplate. If the Mixer Unit is removed from the transmitter connect it to the external power unit.
- (ii) Connect a valve voltmeter across RL31(3N) in the Monitor Frequency Changer Unit, i.e. across the output of the Harmonic Generator Unit. Set all cores and trimmers to approximately their mid-positions.
- (iii) Set the Harmonic Generator Frequency range SWA(3K), fHG Mc/s, to the 4/8 Mc/s range.
- (iv) Connect a Signal Generator to the 'HG INPUT' socket, SKR(4H) and apply an input at 4 Mc/s of approximately 1 to 2 volts. Set the HG TUNE control to the 4 Mc/s tuning point given by the calibration curves. Adjust TR1(3J), L2(6K) and TR3(8J) for maximum reading on the valve voltmeter.

- (v) Set the HG TUNE control to the 8 Mc/s point given by the calibration curves (Fig.2).
Adjust C6(3H), C32(7H) and C50(8I) for maximum on the valve voltmeter.
- (vi) Repeat (iv) and (v) as often as necessary, but tune the 'HG TUNE' control for maximum on the valve voltmeter after reference to the calibration curves, adjusting the coils and trimmers until no increase in output occurs on readjustment.
- (vii) Set the fHG Mc/s switch to 8/16 Mc/s.
- (viii) Set the 'HG TUNE' control to the 8 Mc/s point given by the calibration curves (Fig.2).
Adjust TR2(4J), L3(6J) and TR4(7J) for maximum reading on the valve voltmeter.
- (ix) Set the 'HG TUNE' control to the 16 Mc/s point given by the calibration curves (Fig.2).
Adjust trimmers C7(3H), C16(5H), C33(6I) and C51(8I) for maximum output on the valve voltmeter.
- (x) Set the panel meter switch SWB(3L), to the 'V2' position.
Set the 'HG TUNE' control approximately as in (viii) and tune it about this point for maximum reading on the panel meter.
Adjust TR2, L3 and TR4 for maximum on the valve voltmeter.
- (xi) Set the 'HG TUNE' control as for (ix) and tune it for maximum reading on the valve voltmeter.
Adjust C7, C16, C33 and C51 for maximum on the voltmeter.
- (xii) Repeat (x) and (xi) as often as necessary, until no increase in output occurs on readjustment.
Check that the maximum on the panel meter and the maximum on the valve voltmeter are coincident.
- (xiii) Set the 'fHG Mc/s' switch to 16/24 Mc/s.
- (xiv) Set the 'HG TUNE' control to the 16 Mc/s tuning point given by the calibration curves.
Adjust L1(5J), L4(6K) and TR5(7L) for maximum reading on the valve voltmeter.
- (xv) Adjust the signal generator frequency to 6.1 Mc/s and set the 'HG TUNE' control to the 24.4 Mc/s point given by the calibration curves (Fig.2).
Adjust C8(4H), C17(5H), C26(5I), C34(6H) and C52(7H) for maximum reading on the valve voltmeter.
- (xvi) Set the panel meter switch SWB to the 'V3' position.
Adjust the signal generator frequency to 4 Mc/s and set the 'HG TUNE' control as in (xiv) and tune it about this point for maximum on the panel meter.
Adjust L1, L4 and TR5 for maximum output on the valve voltmeter.

- (xvii) Adjust the signal generator frequency to 6.1 Mc/s and set the 'HG TUNE' control as in (xv) and tune it for maximum on the valve voltmeter, then adjust trimmers C8, C17, C26, C34 and C52 for maximum on the valve voltmeter.
- (xviii) Repeat (xvi) and (xvii) as often as necessary until no increase in output occurs on readjustment.
Check that the maximum on the panel meter and the maximum on the valve voltmeter are coincident.
- (xix) The voltage readings obtained on the valve voltmeter at all frequencies should be between 6.0 and 8.0 volts.
The preliminary adjustment of the Harmonic Generator is now complete.
- (xx) Disconnect the valve voltmeter.

11.3.2 Preliminary Alignment of the Mixer and Stages 1, 2 and 3

NOTE 1: *If the Unit has been removed from the transmitter a dummy load will now be required. The dummy load should consist of a 220Ω 2W resistor in parallel with 33 pF capacitor.*

NOTE 2: *The frequencies used in this section and sections 11.2.3 and 11.2.4 will depend on the transmitter and on the Drive Units to that transmitter. Specific frequencies are therefore not given in the following text, and reference should be made to Table 4 in Supplement 3. The asterisked figures relate to the right-hand column of Table 4.*

- (i) Connect the dummy load across the output of the Unit, i.e. from SKQ(8M) to earth.
Connect a valve voltmeter in parallel with the load via 2 yds of 75Ω coaxial cable.
If the Unit has not been removed from the transmitter the normal Stage 4 feed and the ST.4 GRID PEAK VOLTMETER should be used.
- (ii) Apply a single tone $\times 1$ input at -6 dB, relative to p.e.p. (250 mW) to Socket SKS(8F).
- (iii) Set SWF(8E) to MANUAL.
Set the mixer balance controls RV1(8G) and C63(8G) to mid-position and the MANUAL gain control RV5(8E) to maximum.
- (iv) Adjust the AMPLIFIER control RV4(8E) Stage 2 cathode current potentiometer, for 25 mA on the panel meter M1.
Adjust RV3(4F), the Stage 3 cathode current potentiometer, for 35 mA on M1.
- (v) Set the mixer range switch SWC(3M) (FRAD Mc/s) to $\times 2$ and set M1 to read mixer cathode current (V7/V8).
- (vi) Set the 'fHG Mc/s' switch to $\times 3$.
Apply an input of $\times 4$ to SKR.
Set the 'HG TUNE' control to the $\times 5$ point given by the calibration curves (Fig.2), then tune it, about this point, for maximum on M1.

- (vii) Set the 'MIXER TUNE' control to the *6 point given by the calibration curves (Fig.2).
Adjust TR6(7M), L12(6L), L16(5L) and TR9(4L) for maximum on the valve voltmeter.
- (viii) Set the 'FHG Mc/s' switch to *7.
Apply an input of *8 to SKR. (See also *9 in Table 4 in Supp.3.)
Set the 'HG TUNE' control to the *10 point given by the calibration curves (Fig.23) and then tune it about this point for maximum on M1.
- (ix) Set the 'MIXER TUNE' control to the *11 point given by the calibration curves.
Adjust C67(7F), C73(6G), C84(5G) and C104(4G) for maximum on the valve voltmeter.
- (x) Repeat (vi) to (ix) as often as necessary but tune the 'MIXER TUNE' control for maximum on the valve voltmeter after reference to the calibration curves (Fig.2), adjusting the coils and trimmers until no increase in output occurs on readjustment.
- (xi) Set the 'FHG Mc/s' switch to *12.
Apply an input of *13 Mc/s to SKR.
Set the 'HG TUNE' control to the *14 point given by the calibration curves (Fig.2) and then tune it, about this point, for maximum on M1.
- (xii) Set the 'FRAD Mc/s' switch to *15.
Set the 'MIXER TUNE' control to the *16 point given in the calibration curves (Fig.2).
Adjust TR7(8M), L13(7M), L17(5L) and TR10(4L) for maximum on the valve voltmeter.
- (xiii) Apply an input of *17 to SKR.
Set the 'HG TUNE' control to the *18 point given by the calibration curves (Fig.2) and tune it about this point for maximum on M1.
- (xiv) Set the 'MIXER TUNE' control to the *19 point given by the calibration curves Fig.2.
Adjust C68(8F), C74(7F), C85(5G) and C105(4G) for maximum on the valve voltmeter.
- (xv) Repeat (xi) to (xiv) as often as necessary, but tune the 'MIXER TUNE' control for maximum on the valve voltmeter after reference to the calibration curves (Fig.2), adjusting the coils and trimmers until no increase in output occurs on readjustment.
- (xvi) Set the 'FHG Mc/s' switch to *20.
Apply an input of *21 to SKR. (See also *22 in Table 4 Supp.3.)
Set the 'HG TUNE' control to the *23 point given by the calibration curves (Fig.2) and tune it about this point for maximum on M1

- (xvii) Set the 'FRAD Mc/s' switch to *24.
Set the 'MIXER TUNE' control to the *25 point given by the calibration curves (Fig.2).
Adjust TR0(8M), L14(7M), L13(6M) and TR11(4M) for maximum on the valve voltmeter.
- (xviii) Set the 'FHG Mc/s' switch to *26.
Apply an input of *27 to SKR.
Set the 'HG TUNE' control to the *28 point given by the calibration curves (Fig.2) and tune it about this point for maximum on M1.
- (xix) Set the 'MIXER TUNE' control to the *29 point given by the calibration curves (Fig.2).
Adjust C69(8F), C75(7F) and C86(6F), C106(4F) for maximum on the valve voltmeter.
- (xx) Repeat (xvi) to (xix) as often as necessary, but tune the 'MIXER TUNE' control for maximum on the valve voltmeter after reference to the calibration curves (Fig.2), adjusting the coils and trimmers until no increase occurs on readjustment.
- (xxi) The voltage readings obtained on the valve voltmeter at all frequencies should be between 5 and 7 volts.
- (xxii) Replace the baseplate and disconnect the external valve voltmeter if necessary.

11.3.3 Balancing the Mixer Stage

(See Note 2 in Section 11.3.2).

Remove the *50 input from the mixer.

Connect a valve voltmeter across C82(6G). (Remove the perspex shield.)

Set the MIXER & MONITOR METERING SWITCH to 'V7/V3'.

Set the BALANCE/NORMAL switch SWE(6F) to the BALANCE position.

Set the 'FRAD Mc/s' switch to *31.

Set the 'FHG Mc/s' switch to '8/1', Mc/s'.

Set the MANUAL control RV5(7E) to maximum.

Set SWF to MANUAL.

Apply an input of *32 to the HG INPUT socket SKR.

Set the 'HG TUNE' control to the *33 point given by the calibration curves (Fig.2) and tune it about this point for maximum reading on M1.

Set the 'MIXER TUNE' control to the *34 point given by the calibration curves (Fig.2) and tune it for maximum on the valve voltmeter.

Adjust the mixer balance capacitor C63(8G) and trimmers C68 and C74 for maximum on the valve voltmeter.

Carefully adjust C63 and the balance potentiometer RV1(7H), alternatively, to reduce the reading on the valve voltmeter to a minimum.

Remove the valve voltmeter; return SWE to NORMAL.

Repeat (xiii), (xiv) and (xv) of Section 11.3.2, if necessary use the external load and external valve voltmeter (see Section 11.3.2, Note 1).

11.3.4 Setting up the Monitor Frequency Changer

(See Note 2 of Section 11.3.2.)

Set the 'FHG Mc/s' switch to $\times 35$ and the 'FRAD Mc/s' switch to $\times 36$.

Set the MONITOR U-link on the front panel to DRIVE (LKA from PLBC to PLBE).

Apply an input of $\times 37$ to the HG INPUT socket SKR(4H).

Apply a single tone $\times 38$ input at -6dB, relative to p.e.p. (250 mW) to socket SKS(8F).

Set the 'HG TUNE' control to the $\times 39$ point given by the calibration curves (Fig.2) and tune it about this point for maximum on M1 (switch setting 'V7/V8' cathode current).

Tune the 'MIXER TUNE' control for maximum output on the 'ST.4 PEAK VOLTS' meter.

Connect a valve voltmeter in parallel with a 75 Ω resistor across the output of the Monitor Frequency Changer at socket SKT(5E).

Tune C128(4E) and C133(5E) for maximum output on the valve voltmeter.

Remove the valve voltmeter and the 75 Ω load.

The Monitor Frequency Changer is now set up.

11.3.5 Final Alignment of the Mixer Unit

The final adjustment of the unit must be carried out, working into its normal load, in the transmitter.

Set the meter M1 to V7/V8 (mixer cathode current).

Apply an input of 4 Mc/s to the HG INPUT socket SKR.

Set the 'FHG Mc/s' switch to '4/8 Mc/s'.

Set the 'HG TUNE' control to the 4 Mc/s point given by the calibration curves (Fig.2) and tune it about this point for maximum on M1.

Carefully adjust the tuning coils L2 and TR3 of the HG amplifier stages for maximum on M1.

Set the 'HG TUNE' control to the 8 Mc/s point given by the calibration curves (Fig.2) and tune it about this point for maximum on M1.

Carefully adjust the trimmers C32 and C50.

NOTE: *Only very slight adjustments will be necessary to obtain optimum results.*

Set the 'FHG Mc/s' switch to '8/16 Mc/s'.

Align the tuning coils L3 and TR4 at 8 Mc/s and the trimmers C33 and C51 at 16 Mc/s in the same manner as range 4/8 Mc/s has been described.

Set the 'FHG Mc/s' switch to 16/24 Mc/s.

Align the tuning coils L4 and TR5 at 16 Mc/s.

Apply an input of 6.1 Mc/s to SKR.

VLM

Align the trimmers C34 and C52 at 24.4 Mc/s (fHG). This should be carried out in a manner similar to that of the 4/8 Mc/s range, the only difference being change in the tuning frequency.

Having completed the final adjustment of the Harmonic Generator, carefully repeat the alignment of the Mixer and Stages 1, 2 and 3 as described in Section 11.3.2, using Stage 4 as the output load and the ST.4 GRID PEAK Volts as the output indicator.

11.4 SETTING UP THE MANUAL DRIVE ASSEMBLIES

All the variable tuning controls are driven by manual drive assemblies mounted on the front panel. There are basically two types, the single turn type and the multi-turn type. The single turn types, the handles of which rotate less than 360°, are used for the RANGE switches and the OUTPUT TUNE controls. The multi-turn types, the handles of which rotate a number of complete revolutions, are used for the remaining controls.

To set up the manual drive assemblies it is necessary to check that:

- (a) the dial stops are correctly set.
- (b) the components are set in the correct position.
- (c) the dials are correctly set.

The correct positions of (a), (b) and (c) are listed below under the control names.

(a) RANGE SWITCH

Dial Stops: 1, 2, 3, 4 & 5
Components: Set as shown in Figs.24 and 25.
Dial set to: 1

(b) OUTPUT TUNE

Dial Stops: 0 and 100 (0 and 200 in HS71/1)
Components: Set the capacitor C64 to maximum capacity with the padders C68, 69, 70 and 71 connected by switch SWP. (See Fig.24 Sketch B.)
Dial set to: 0

(c) STAGE 4 TUNE

Dial Stops: 0 and 210
Components: Set the turret with the largest inductor (L10) connected across the capacitor C12. Set C12 to maximum capacity (ready to tune L10).
Dial set to: 0

(d) STAGE 5 TUNE

Dial Stops: 0 and 210
Components: Set the inductor (L15) wiper contacts to within approximately $\frac{1}{8}$ turn (2 inches) from the right-hand end of inductor.
Dial set to: 210

(e) STAGE 6 TUNE

Dial Stops: 0 and 210
Components: Set the inductor (L19) wiper contacts approximately $\frac{1}{4}$ turn (3 inches) from the top of the inductor.
Dial set to: 210

(f) STAGE 6 COUPLING

Dial Stops: 0 and 210
Components: Lower the inductor to the full extent of the extension rods, and set the inductor by rotating the front driving shaft approximately $\frac{1}{2}$ turn.
Dial set to: 0

(g) STAGE 7 INPUT TUNE

Dial Stops: 0 and 210 (0 and 105 in HS71/1)
Components: Set the contact to within 2 inches of the bottom of the coil.
Dial set to: 210 (105 in HS71/1).

(h) FEEDER TUNE

Dial Stops: 0 and 200
Components: Turn capacitor spindle fully anticlockwise, then back $\frac{1}{2}$ turn (care must be taken not to exceed the normal limits of travel).
Dial set to: 0

(j) STAGE 7 TUNE

Dial Stops: 0 and 210
Components: Set the inductor (L33) wiper contacts approximately $\frac{1}{4}$ turn (3 inches) from the top of the inductor.
Dial set to: 0

(k) FEEDER COUPLING

Dial Stops: 0 and 210
Components: Lower the inductor (L34) to the full extent of the extension rods, and set the inductor by rotating the front driving shaft approximately $\frac{1}{2}$ turn.
Dial set to: 0

(l) ST.7 AND OUTPUT RANGE SWITCH

Dial Stops: 1, 2, 3, 4 and 5
Components: Set switch rotor blades (SWR) to engage all contacts. (See also Fig.21.)
Dial set to: 1

NOTE: Slight adjustment may be required when fitting the assemblies to the couplings but the above settings allow for this. After fitting, check the complete range coverage.

11.5 SETTING UP THE MECHANICAL DRIVES

Layout: Figs.24 and 25.

Assembly details of the following controls are given on the above-mentioned drawings:-

RANGE Control
 OUTPUT TUNE
 ST.7 AND OUTPUT RANGE SWITCH
 FEEDER TUNE

11.6 FUSE LIST

Table 5

Fuse	Function	Rating
FS1	50V D.C. Rectifier A.C. input	2A
FS2	50V D.C. Rectifier A.C. input	2A
FS3	50V D.C. Rectifier A.C. input	2A
FS4	Fan Starter supply	2A
FS5	6.3V Fils. and Aux. H.T. Rect. Fils. Supply	2A
FS6	Stage 7 Bias Supply	4A
FS7	Main H.T. Fuse	} not used in HS71/1 50A
FS8	Main H.T. Fuse	
FS9	Main H.T. Fuse	
FS10	} Stages 5 and 6 and main H.T. Rectifier Filaments Supplies	4A
FS11		4A
FS12		4A
FS13	Not used on HS71	
FS14	Stage 7 Filament Supply	6A
FS15	Stage 7 Filament Supply	6A
FS16	Aux. H.T. Unit Supply	2A
FS17	General Bias Supply	2A
FS18	Filament Delay Switch Supply	500 mA
FS19	Not used on HS71	
FS20	Not used on HS71	500 mA
FS21	Not used on HS71	
FS22	'Ledex' switch control supply	1A
FS23	50V D.C. Supply to control relays up to Aux. H.T. relay	3A
FS24	Main H.T. contactor and overload reset relay control supply	5A
FS25	Indicator lamps supply	1A
FS26-FS35	Not used on HS71	

11.7 AIR FILTERS

The air filters consist of closely folded polythene filtering medium rigidly welded at every fold to transverse polythene supports, the whole being mounted into a synthetic resin frame, which is made to make an air-tight seal with the filter holder.

To clean the filters they should be removed from the holder and washed in lukewarm (not more than 120°F) solution of any of the common industrial or household detergents. The detergent has no harmful effect on either polythene or resin frame and so, in obstinate cases, a strong solution may be used. However, in normal atmosphere and if washing is carried out regularly, the filter should come completely clean in quite weak solution.

The filter may be soaked and agitated in the solution to help remove the dirt.

When clean the filter should be removed from the detergent solution and rinsed in a cold water bath or under the tap until all signs of the detergent have been removed. The filter should then be allowed to dry naturally before replacing in the filter frame. Artificial heat should not be used to accelerate the drying process.

11.8 REMOVAL OF FRONT PANELS

The upper and lower front panels of the L.H. R.F. Unit and all the front panels of the R.H. R.F. Unit are removable.

The upper panel containing the RANGE control handle and FEEDER TUNE control can be removed by:

- (a) removing the screw in the handle of the STAGE 5 H.T. INTERLOCK switch and pulling of the handle,
- (b) releasing the four hexagonal headed captive screws, two on each side of the panel, and lifting the panel off.

The lower panel containing the ST.6 TUNE and ST.6 COUPLING can be removed by:

- (c) releasing the four hexagonal headed captive screws, two on each side of the panel, and easing the panel forward. Care must be taken as the panel is connected by a tagboard to the cabinet cableform mounted on the left-hand side of the panel.

The four panels on the front of the R.H. R.F. Unit can be removed by first removing the manual heads, then releasing the four hexagonal headed captive screws, two on each side of the panel, and lifting away from the front of the cubicle.

In HS71/1 the panel holding the Stage 7 Range switch and Reflectometer Controls panel should be eased forward to disconnect the socket of the Reflectometer Controls Panel.

11.9 AIR INTERLOCK SWITCH SETTING

The air switch is adjustable from 0-10 inches W.G. and the blowers tend to give a constant pressure independent of the air flow. The air switch is fitted on the air ducting outside the transmitter and its position may vary from installation to installation. It is advisable to set the operating point at about the rated pressure of the blower.

The switch is normally set to operate at $4\frac{1}{2}$ inches W.G. by means of the knurled wheel inside the case. The trip setting is shown by the scale on the front of the unit.

11.10 REPLACEMENT COIL CONTACTS

Sintered bronze ball contacts were originally fitted to coils L19 and L33 (Item 40 on Sketch C, Fig.10A, and on Sketch H, Fig.12A).

Should these coil contacts require replacing, fit Spring Contact and Guide Wheel Assembly Ref.10AS/5950-99-933-2057 (Marconi WZ.31079/B); this uses silver graphite contacts and incorporates a $1\frac{1}{4}$ inch diameter Guide Wheel (original was $1\frac{1}{8}$ inch diameter).

To ease running-in of new contacts, apply the thinnest possible film of medium grease to the coil, then wipe it off again immediately; the trace of grease remaining will be adequate for running-in purposes.

In normal use, no lubricant whatever should be used.

11.11 BACK-FIRE INDICATORS

The blowing of one or more of the h.t. fuses FS7-9 in the Rectifier and Control Unit (L.H.) can be due to reverse current, i.e. back-fire in one or more of the six GXU2 h.t. rectifiers. To ascertain whether any of these have back-fired, use the compass WIS.7204/C Ref.1 provided in the modification kit to check the polarity of the cores of chokes L12-17 in the anode circuits of the valves V1-V6 shown on Figs.8 and 20A. Normally the polarity of all six cores should be the same, and reversed polarity of any core indicates that the associated rectifier valve has back-fired. After changing the valve, and before switching on, reverse the core of the associated choke so that it will give the same polarity indication as the others.

11.12 USE OF ACT70 VALVES

The ACT70 valve is now the preferred type of valve for use in the HS31 and 71 series of transmitters. It is mechanically a direct replacement for the BR191B. While power output and distortion are not affected by the change, slightly different set up conditions are required. These are detailed as follows:-

1. The 10 k Ω resistor at the negative end of Stage 5 screen potentiometer (R19) should be changed for one of value 15 k Ω (PC.67006/20) and the static current adjusted to 40-60 mA.

2. The static cathode current of Stages 6 and 7 should be adjusted to 0.2 amp or 0.7 amp respectively.

These values may be set during adjustments for optimum linearity between 0.2 and 0.3 amp for Stage 6 and between 0.5 and 0.7 amp for Stage 7.

3. The grid cathode currents of Stages 6 and 7 should be adjusted by drive level and coupling as follows:-

Service	Power	Stage 6		Stage 7	
		I _g	I _c	I _g	I _c
C.W./F.S.K.	7 kW	40/60 mA	0.5/0.7A	450/550 mA	3.25A
I.S.B. 2 Tone	9 kW p.e.p.	20/30 mA	0.5/0.65A	220/280 mA	2.65A
D.S.B. Carrier	3.5 kW			150 mA	2.3A

NOTE: Stage 5 cathode current will be found to be between 110 and 140 mA on C.W./F.S.K. and 80 and 110 mA on I.S.B. (2 Tone).

Table 6
Abridged Valve Data

Type	Services Spec'n No.	Description	Valve Base	Filament		Max. Op'g Anode V	Max. Op'g Screen Grid V	Max. Anode Diss W	Imped. Ω	Ampl'n Factor	Mutual Cond. mA/V	Max. d. c. mA	Remarks
				Volts	Amps								
BR191B or ACT70	-	Triode	-	12.6	29	6.25k	-	3k	-	29	14	-	
GXU2	CV2518	Power Rectifier	B4F	5	7.1	-	-	-	-	-	-	-	Peak anode current 5A d. c. output 9.6 kV
N77	CV136	Output Tetrode	B7G	6.3	0.2	250	250	5	-	-	2.6	-	
QY4250/ or C1112	CV2131	Tetrode	B5F	5	14.1	4k	600	250	-	5.2	4	-	
5RG4Y	CV717	FW Rectifier	I0	5	2.8	500+ 500	-	-	-	-	-	250	
Z77	CV138	Pentode	B7G	6.3	0.3	250	250	2.5	0.3M	-	7.4	-	
5B 255M	CV391	Beam Tetrode	B8G	6.3	0.9	600	300	25	-	9	6	-	
5B 254M	CV428	Beam Tetrode	B8G	6.3	0.9	600	300	25	-	9	6	-	
	CV448	Germanium Crystal				P. I. V. 100			900 at 1V			25	

⚡ If required to operate on I.S.B., see Note at bottom of Page 4A.

Table 6 (Contd.)

STABILISERS

Type	Services Spec'n No.	Description	Valve Base	Striking Voltage V	Operating Voltage limits		Maximum tube current limits	Regulation over current range V	Stability ±%		Base Connection pins			Ω
					Volts	at tube current mA			100 hr. period	1000 hr. period	Anode	Cathode	Shorted	
* STV280/80	CV1069	Stabiliser	5 pin Brit.	A1. 110 A2. 210 A3. 320 A4. 420	60-80 120-160 180-240 260-300	40	10-100 10-90 10-70 10-70	-	5	15	-	-	-	40
QS1206	CV686	Stabiliser	I0	133	108	-	5-40	4.0	-	-	5	2	3 & 7	-

* STV280/80S Semi-conductor Stabiliser in HS71/1

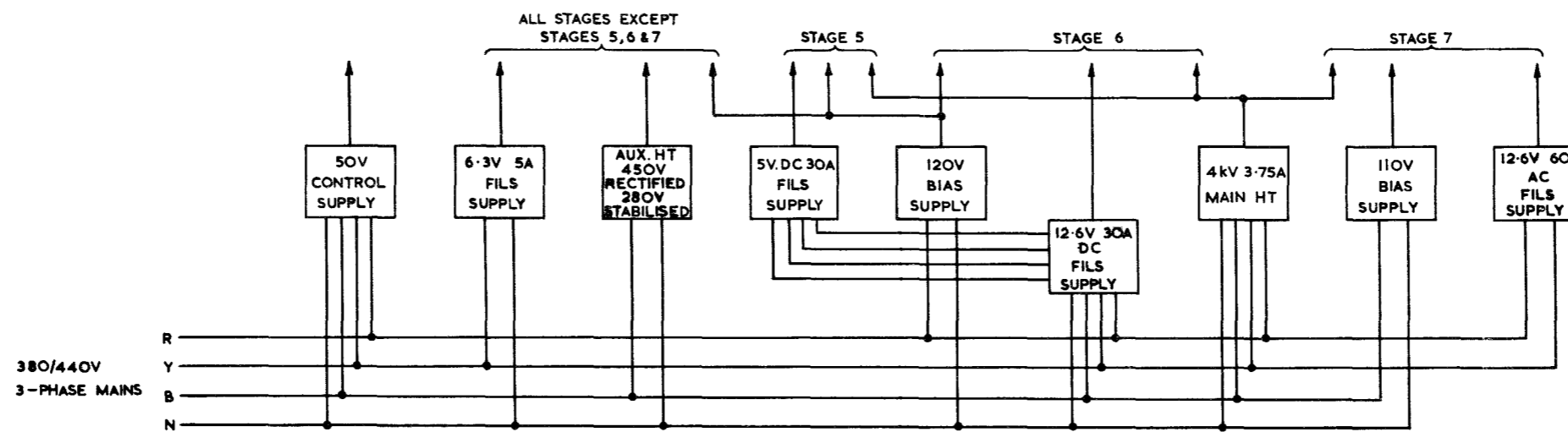
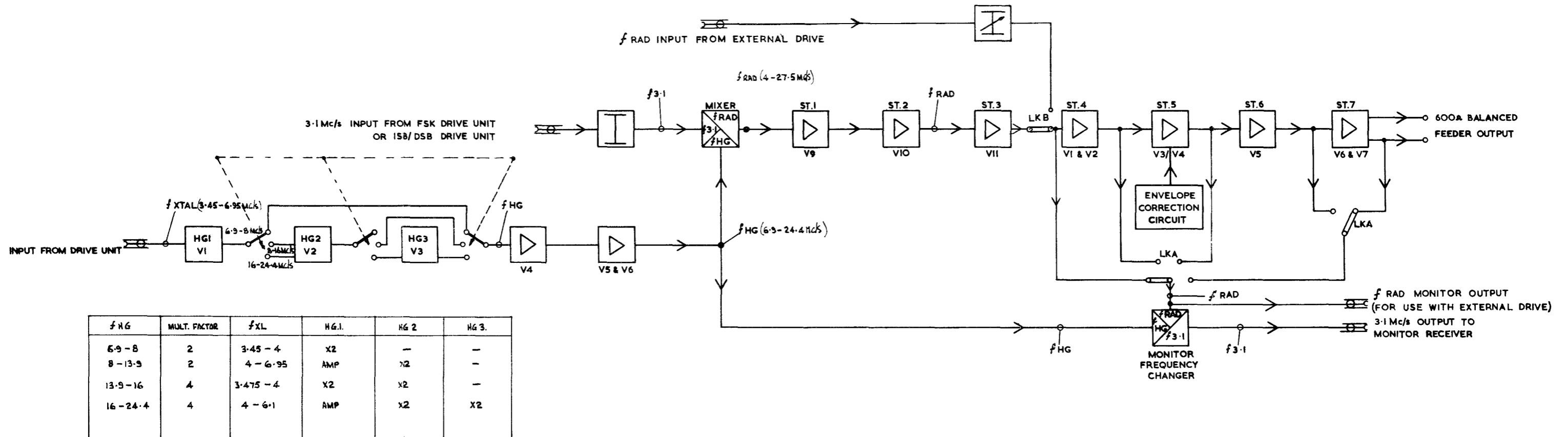

Note.
 This diagram applies also to HS71/1 but (i) for Link LKB between ST.3 and ST.4 read LKA, and (ii) ignore upper arrowed Output line marked '600 OHM BALANCED'.

AP.116E-0232-1, AL.5

HS71 TRANSMITTER BLOCK DIAGRAM
 (WZ. 15035/D Sh. 1 Iss. 3)

FIG.1A BLOCK DIAGRAM

Changes arising from Modification 1312

(Monitoring of Transmitter, Radio Type T.10197B
when radiating on frequencies between 2.5 and 20 Mc/s).

The modification applies only to Transmitter, Radio, Type T.10197B(HS.71A) in the HS.71 series, and involves the use of an I.F. of 3.1 Mc/s throughout the fRAD range.

The fxtal/fHG conversion table on Fig.1A applies to HS.71 and HS.71/1 (fRAD 4-27.5 Mc/s) when using an I.F. of 3.1 Mc/s. The conversion table relating to HS.71A when using an I.F. of 3.1 Mc/s to permit the use of Monitor, R.F., Type 10160 (Marconi HD.24) under Modification 1312 is given below. The fxtal DRIVE input to SKB will then range from 3.2 to 6.55 Mc/s.

Transmitter, Radio, Type T.15086 (HS.71A) using 3.1 Mc/s I.F.								
fRAD (Mc/s)	fRAD switch (SWC) setting	fHG (Mc/s)	Mult. Factor	fHG switch (SWA) setting	fxtal (Mc/s)	HG.1 (V1)	HG.2 (V2)	HG.3 (V3)
2.5-2.9	2.5-5	5.6-6.0	1	4-8	5.6-6.0	Amp.	-	-
3.3-4.9		6.4-8.0	2		3.2-4.0	X2	-	-
4.9-5.0	5-10	8.0-8.1	2	8-16	4.0-4.05	Amp.	X2	-
5.0-10.0		8.1-13.1	2		4.05-6.55	Amp.	X2	-
10.0-19.1		13.1-16.0	4		3.275-4.0	X2	X2	-
19.1-20.0	10-20	16.0-16.9	4	16-24.4	4.0-4.225	Amp.	X2	X2

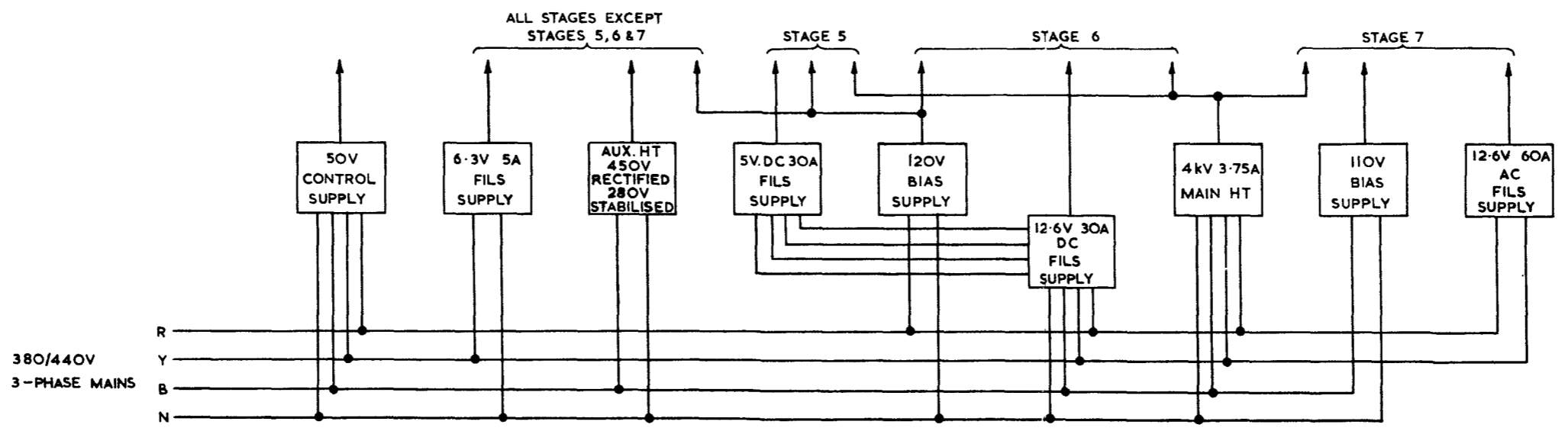
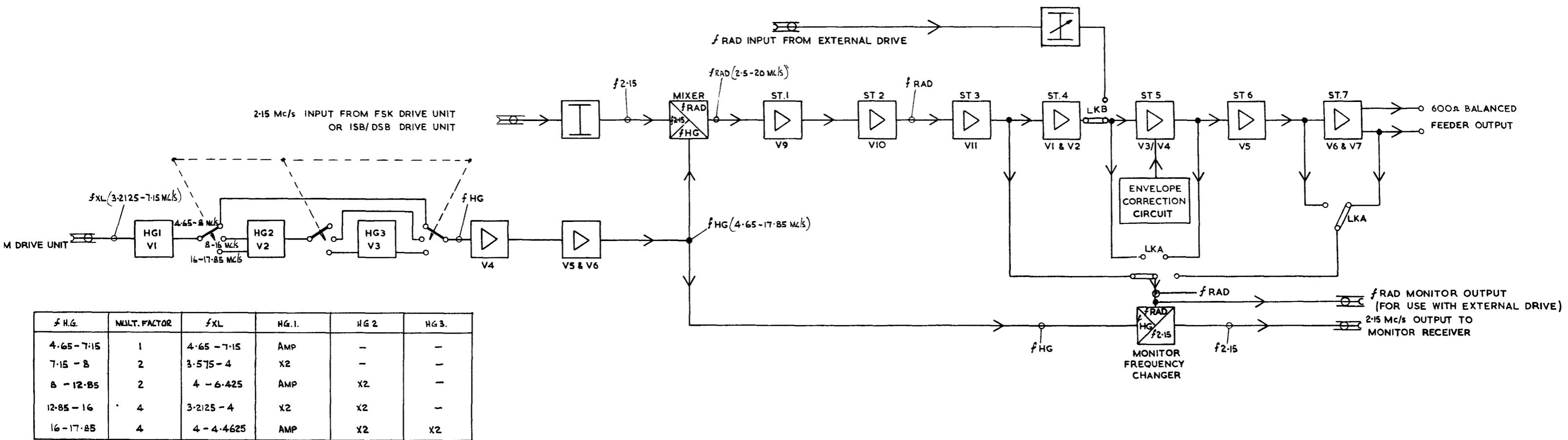

BLOCK DIAGRAM
 HS71A TRANSMITTER
 WZ.18270/D Sh.1 Iss.2

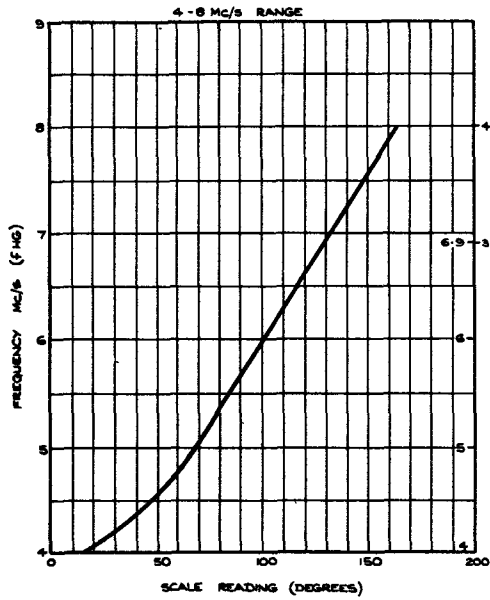

H.O. FREQUENCY Mc/s (f XC)

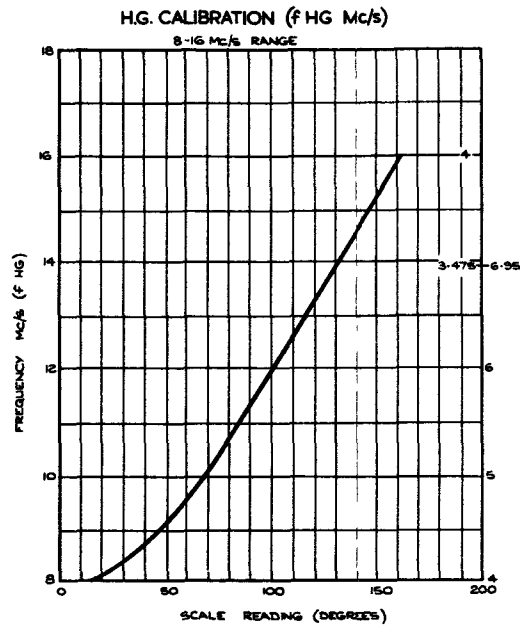

H.O. FREQUENCY Mc/s (f XC)

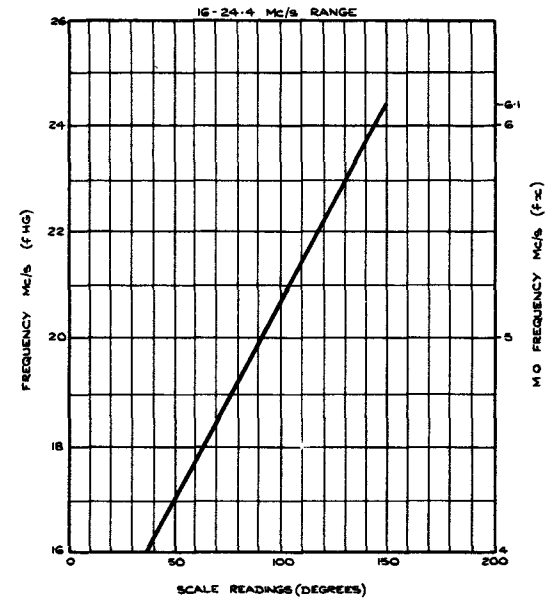

H.O. FREQUENCY Mc/s (f XC)

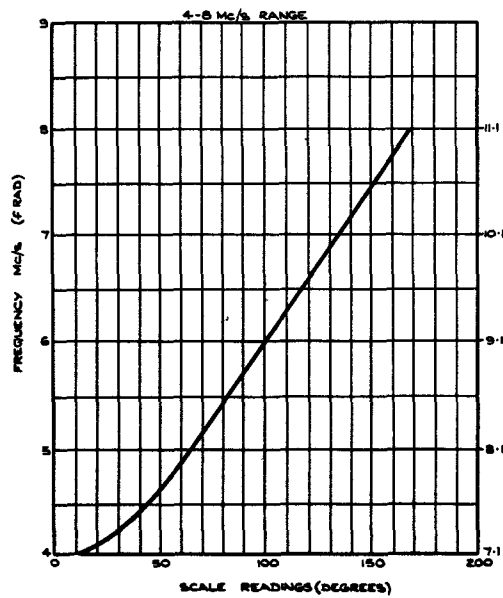

FREQUENCY Mc/s (f HG)

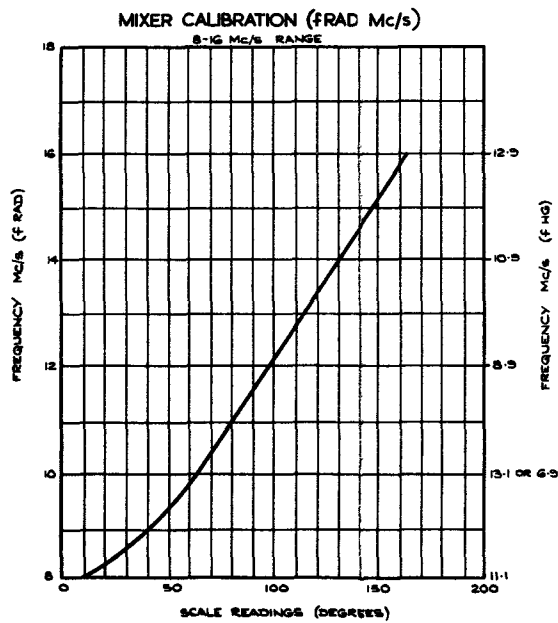

FREQUENCY Mc/s (f HG)

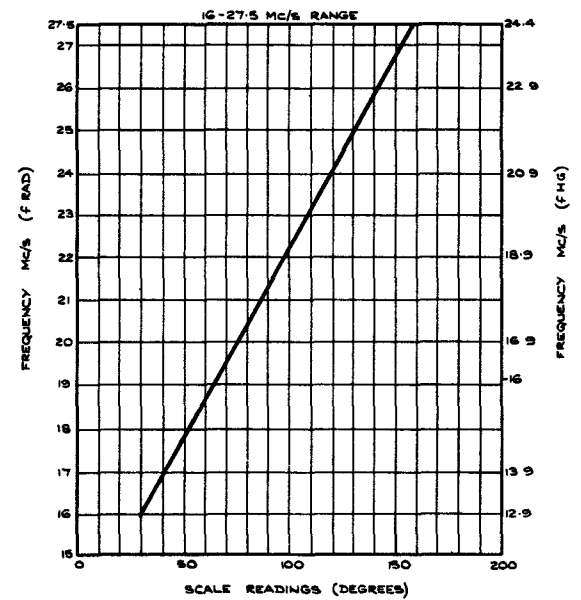

FREQUENCY Mc/s (f HG)

CALIBRATION CURVES, PART 1 TRANSMITTER TYPE HS71 AND HS71/1 (MS)
(WZ.15043/D Sh.1 Iss.1)

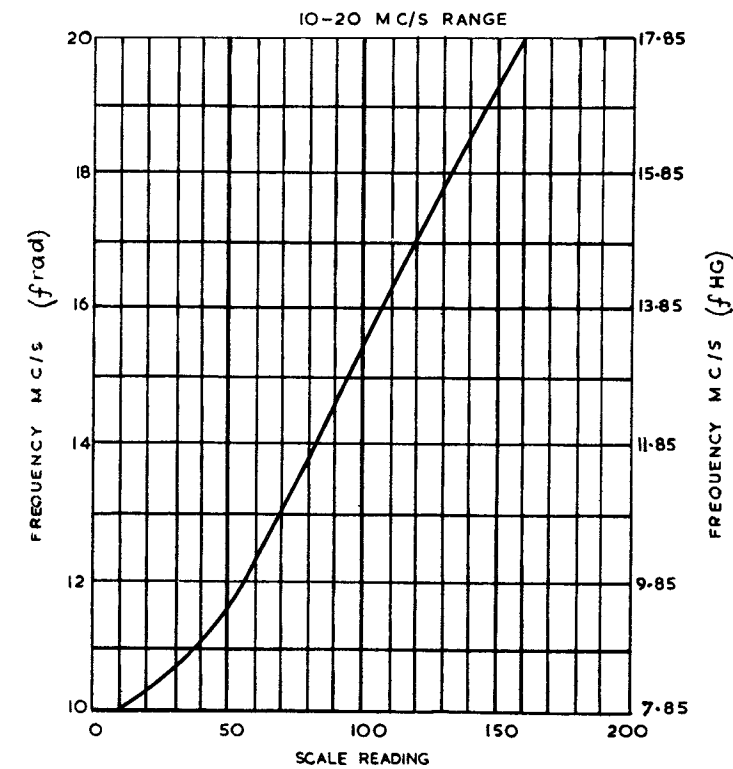
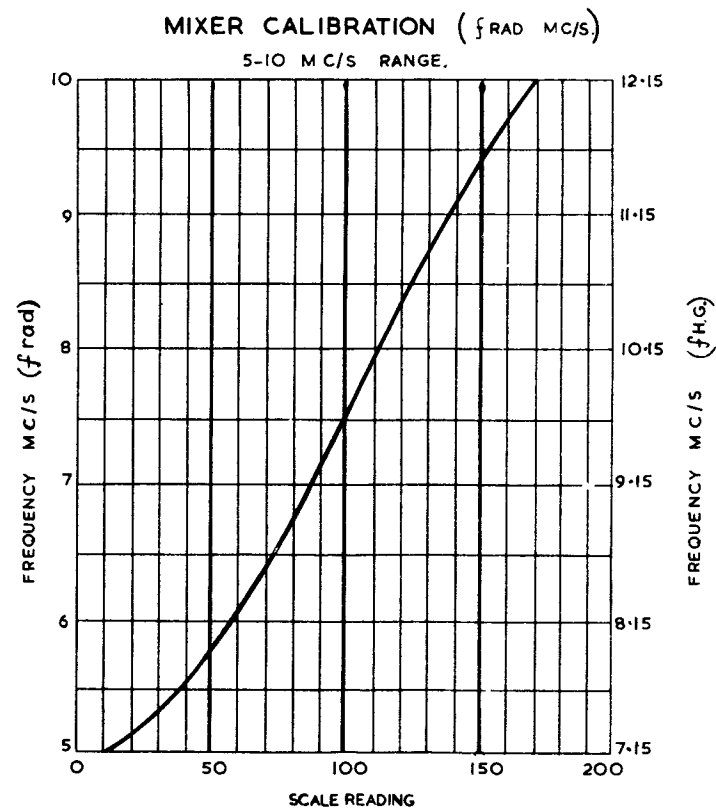
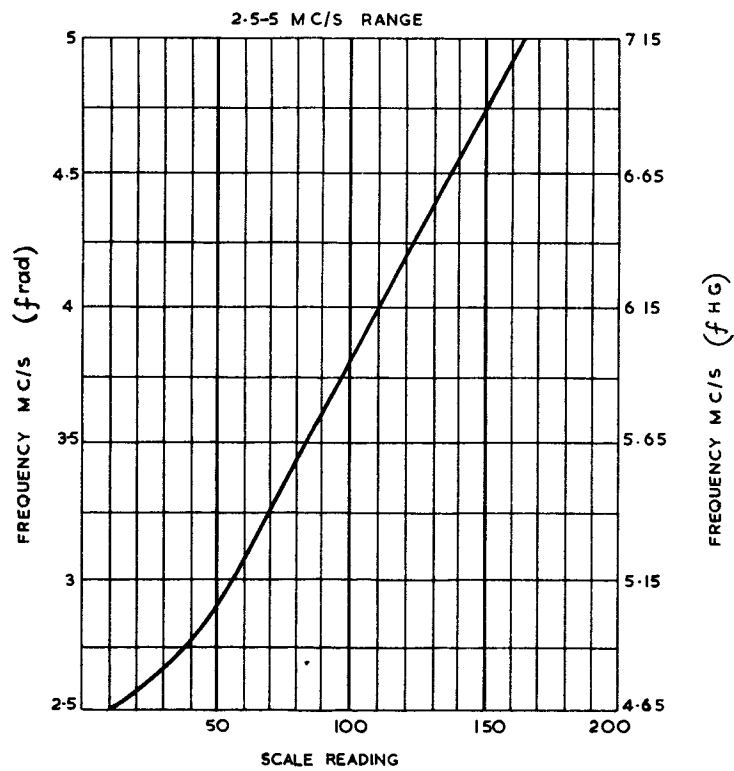
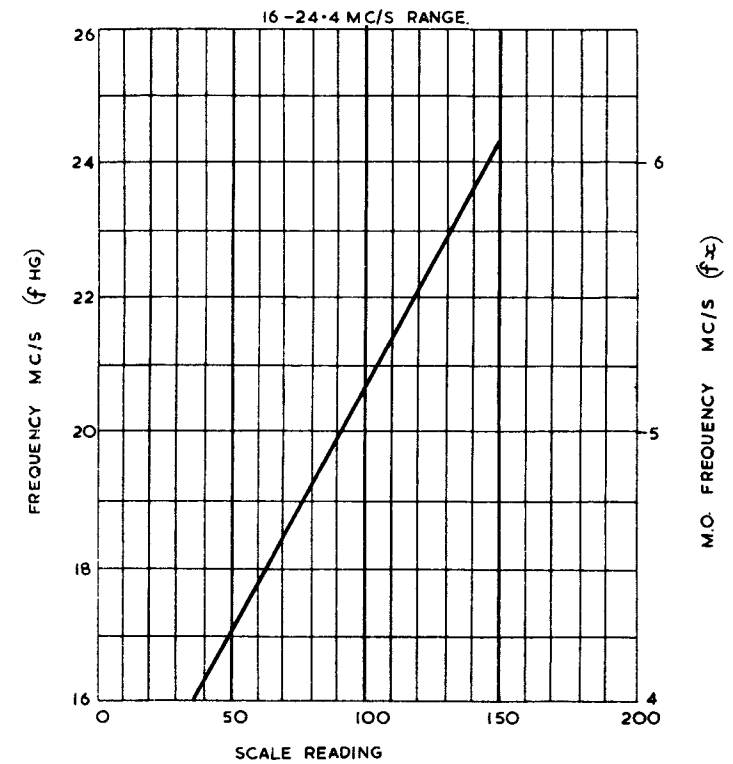
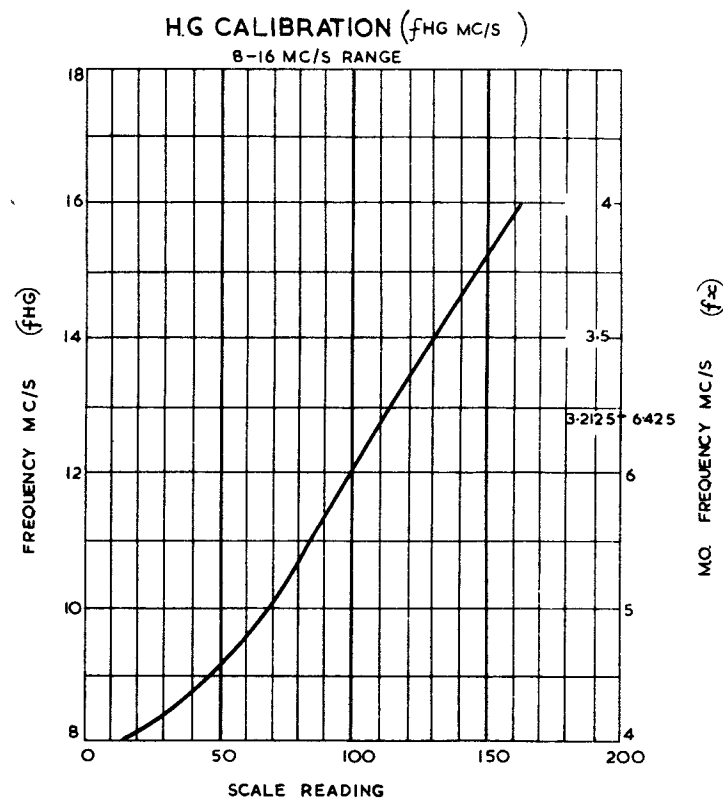
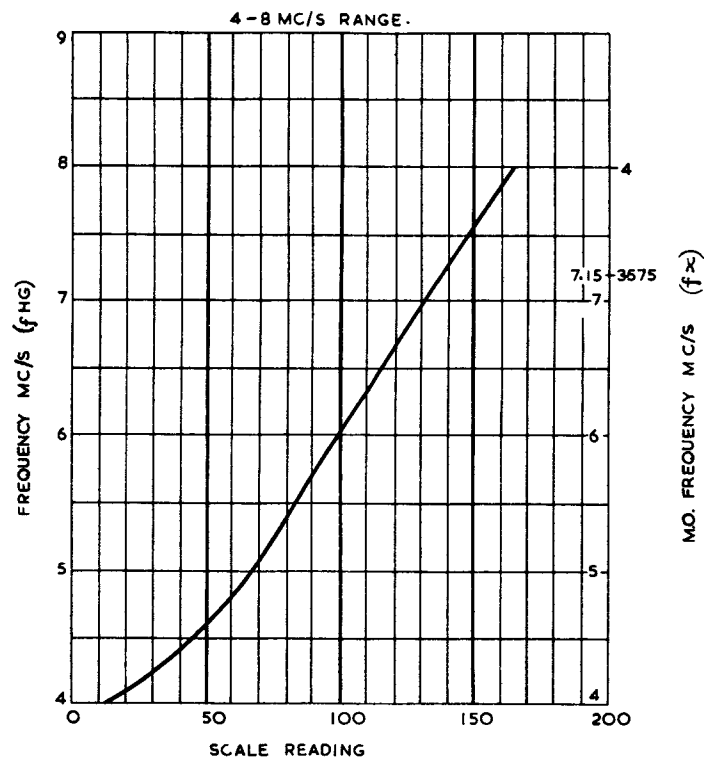

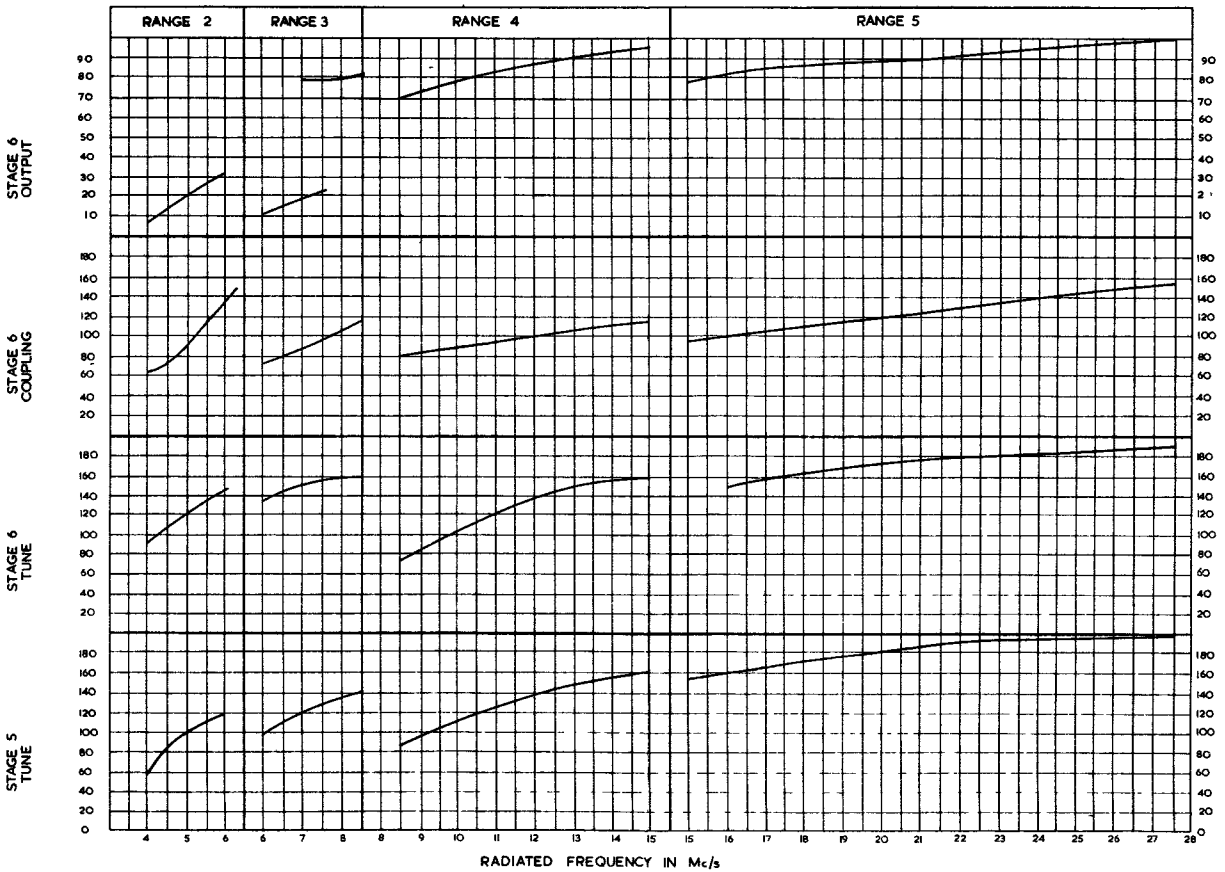
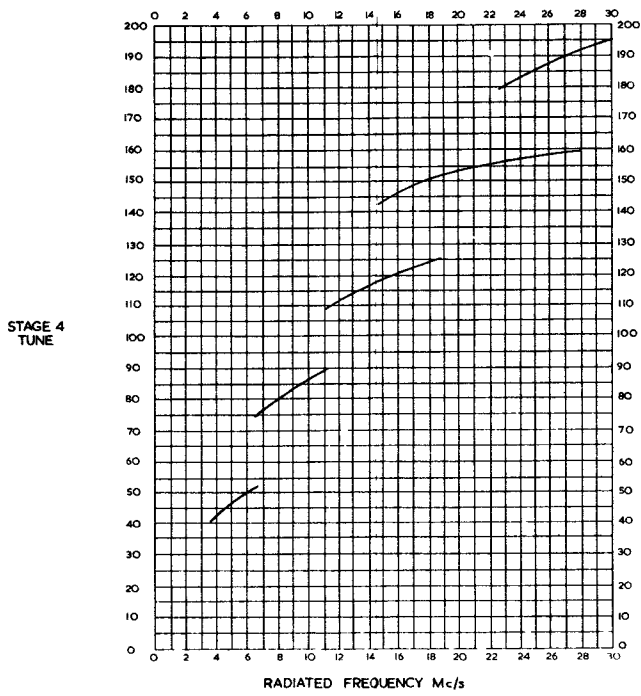

CALIBRATION CURVES, PART 2 TRANSMITTER TYPE HS71
(WZ. 15043/D Sh. 2 Iss. 2)

FIG. 3

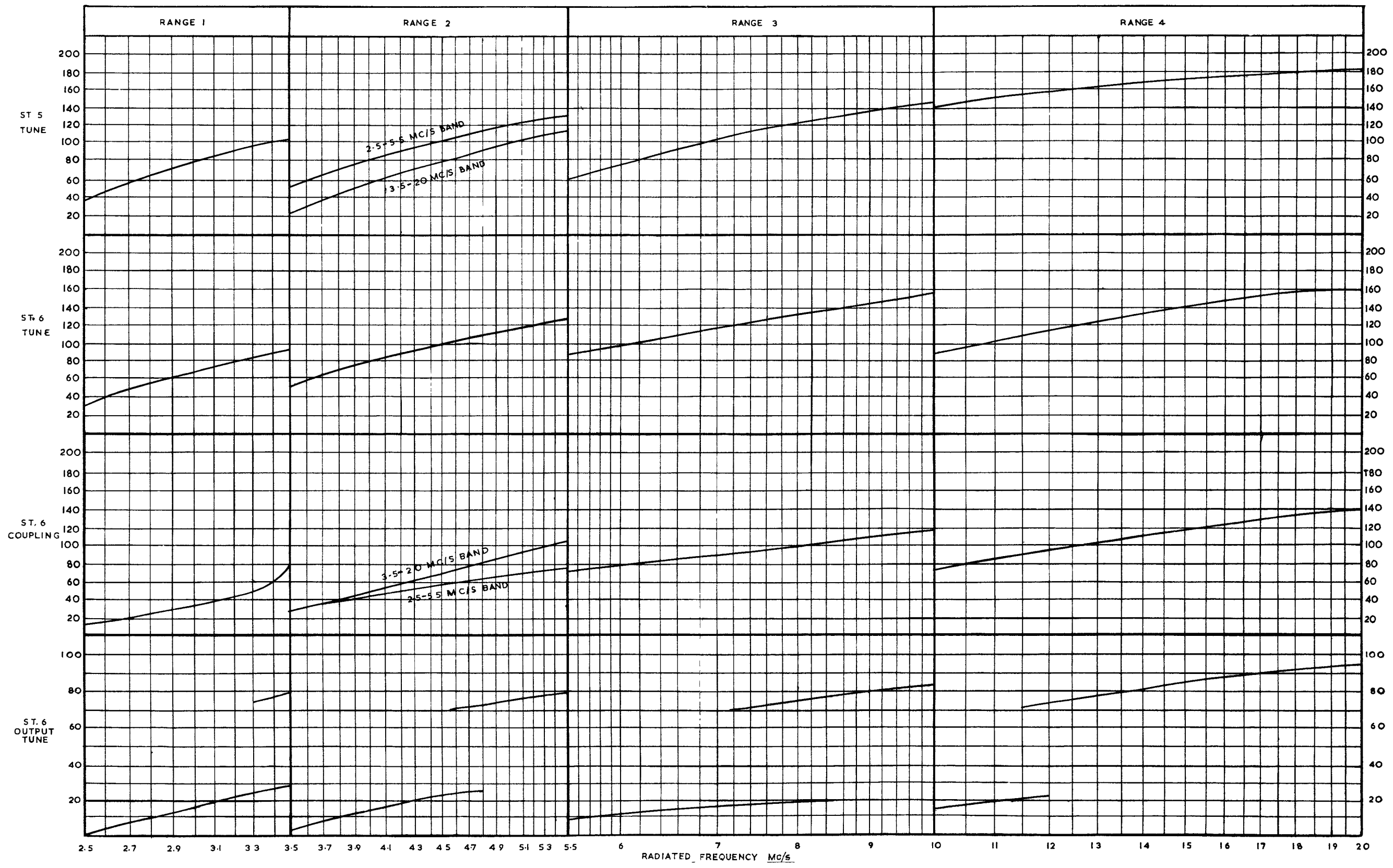
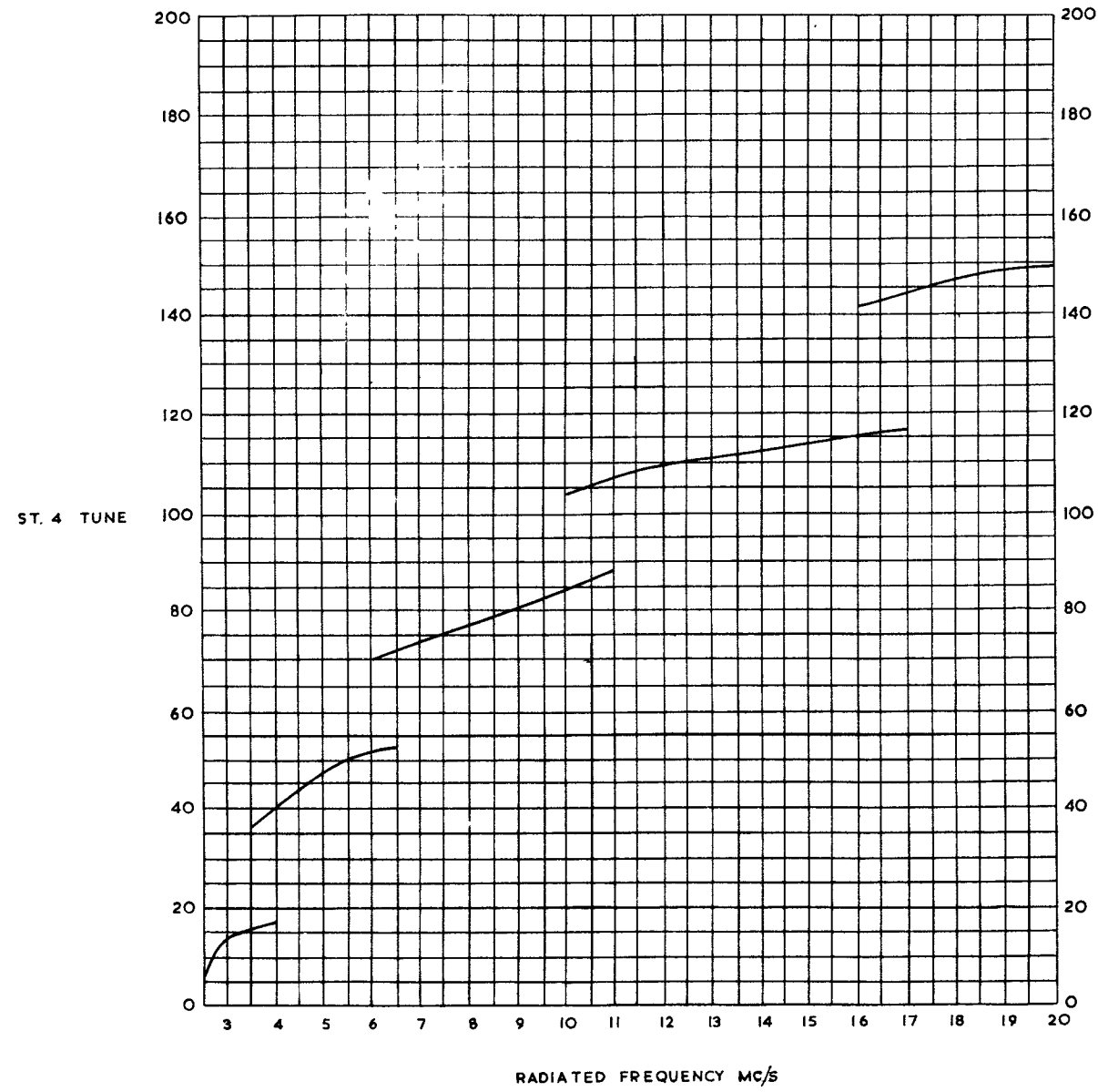

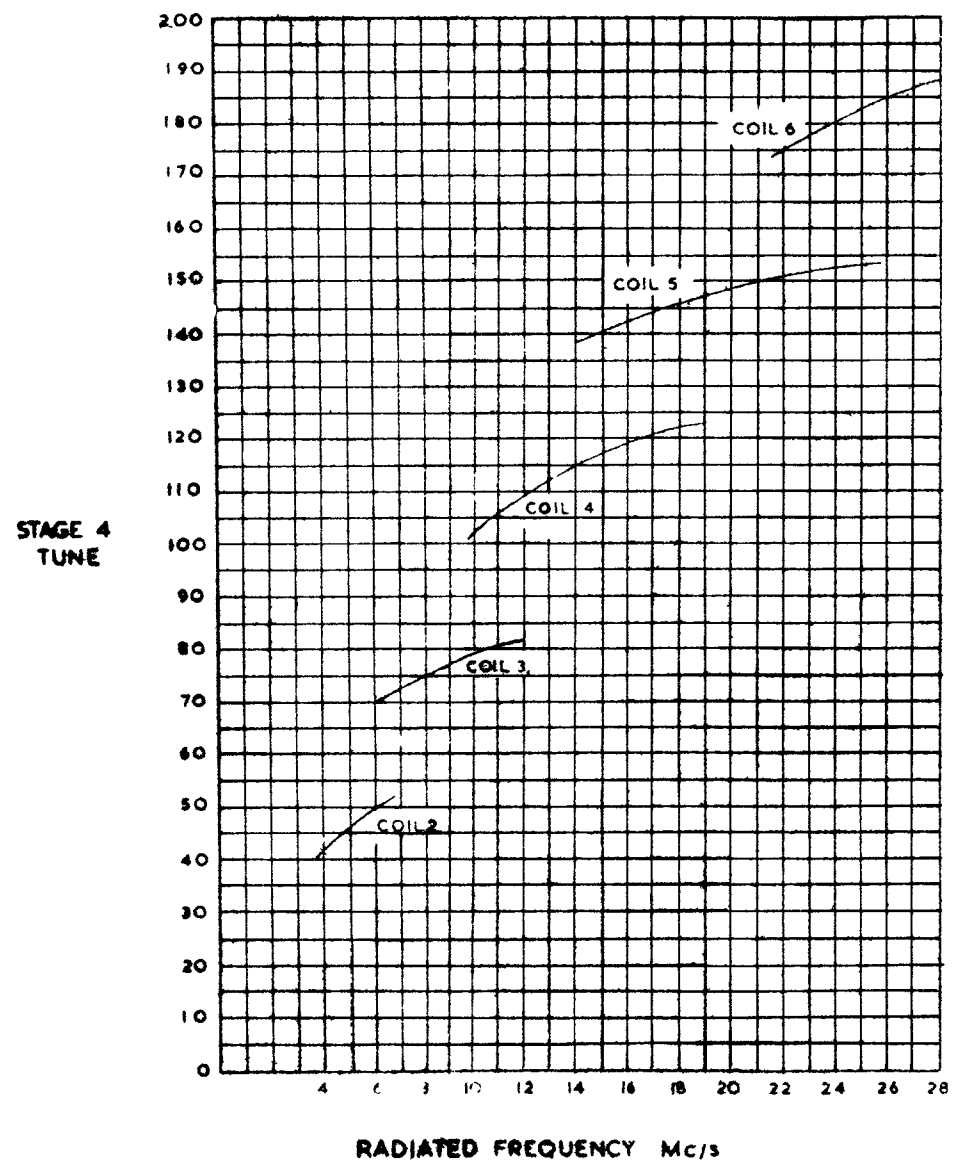

AP.116E-0232-1
AL.5,MAR.'67

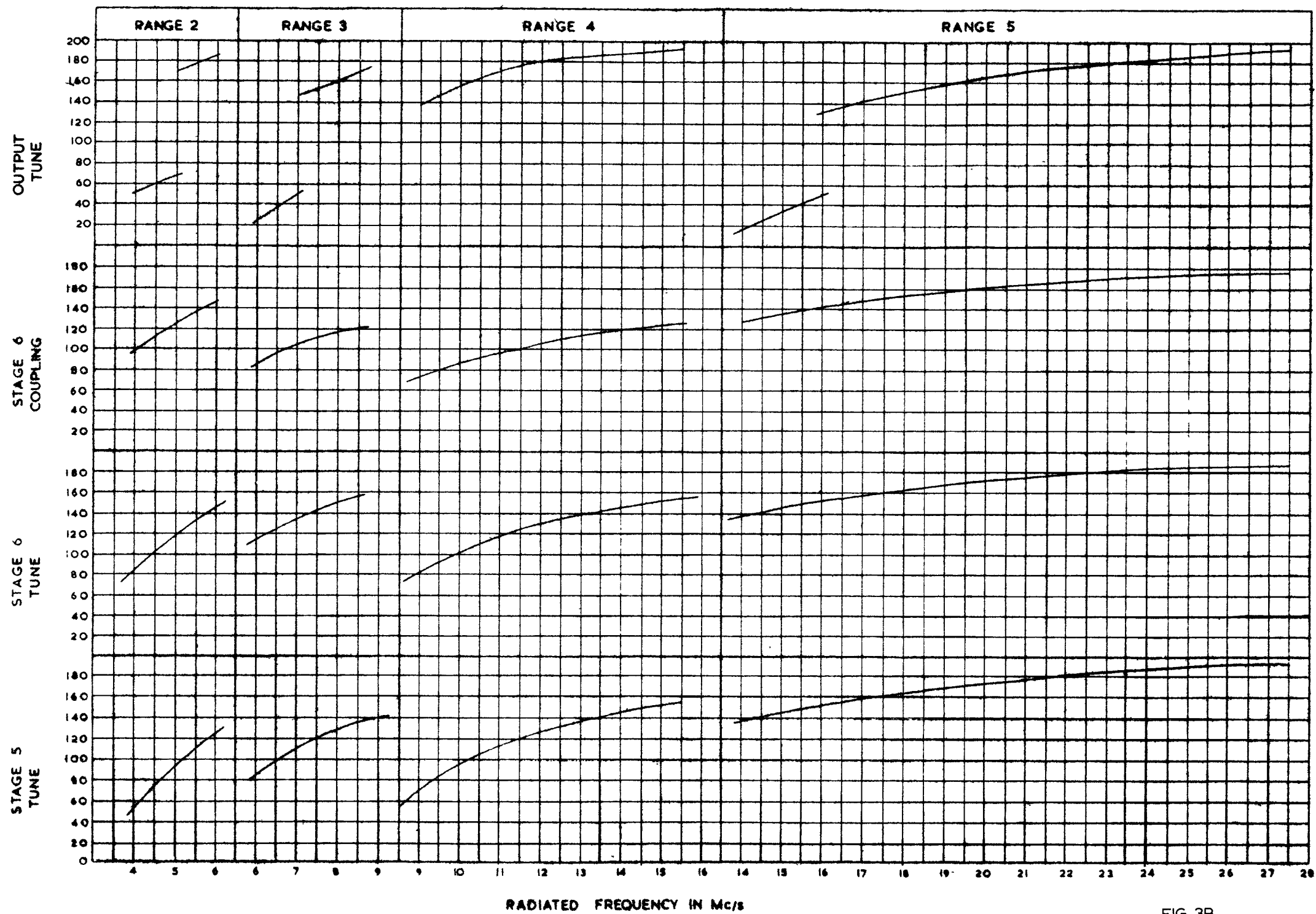
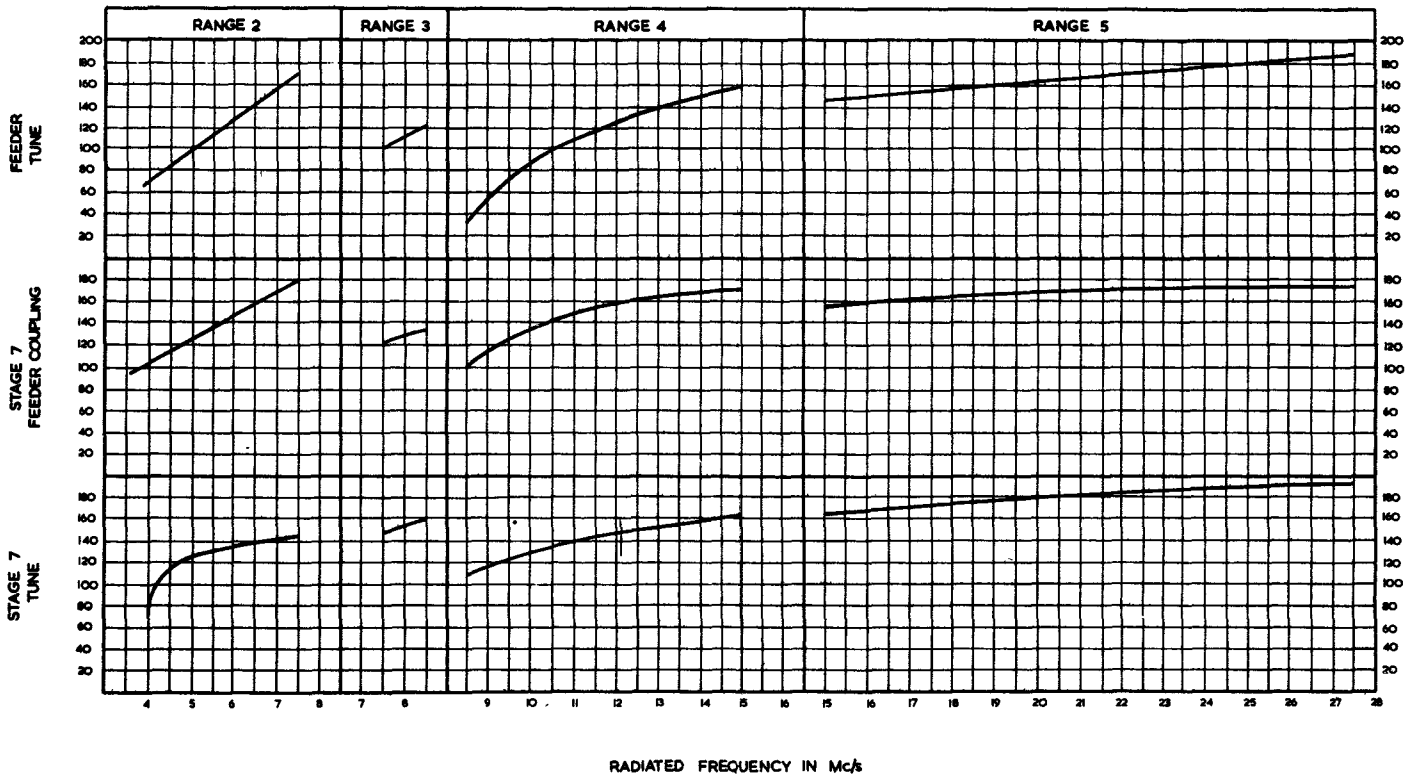
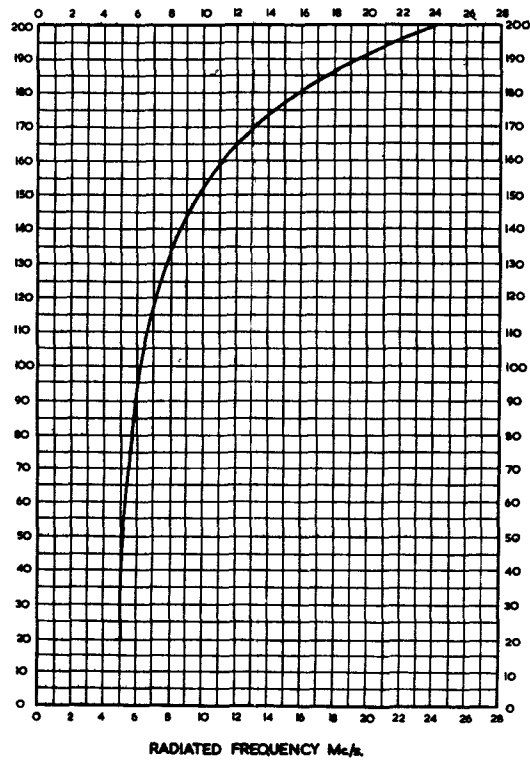

FIG. 3B
CALIBRATION CURVES (PART 2)
TRANSMITTER TYPE HS71/1
WZ. 28345/D SH.2.

STAGE 7
CATHODE TUNE



CALIBRATION CURVES, PART 3 TRANSMITTER TYPE HS71
(WZ. 15043/D Sh. 3 Iss. 1)

FIG. 4

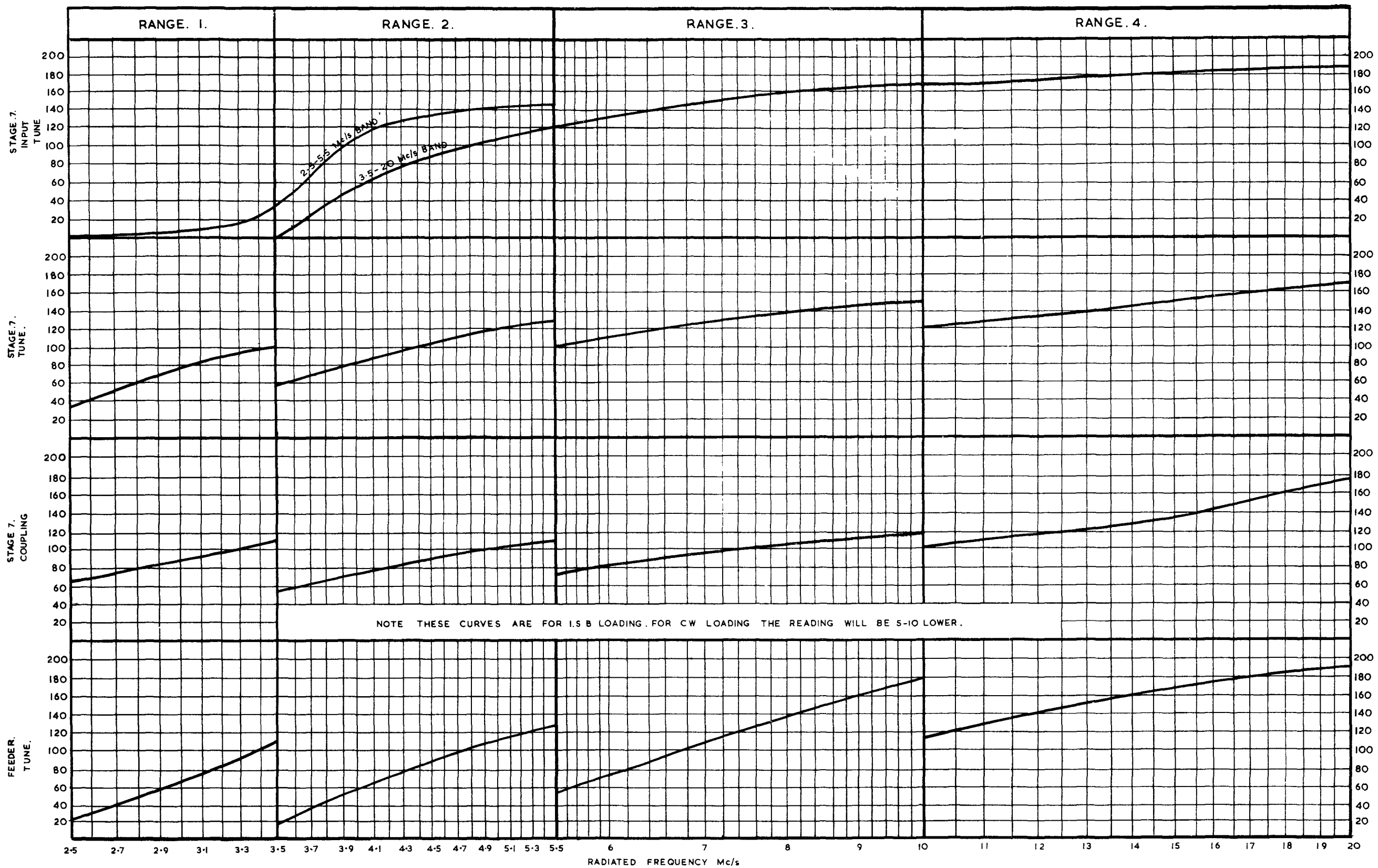

STAGE 7
CATHODE TUNE

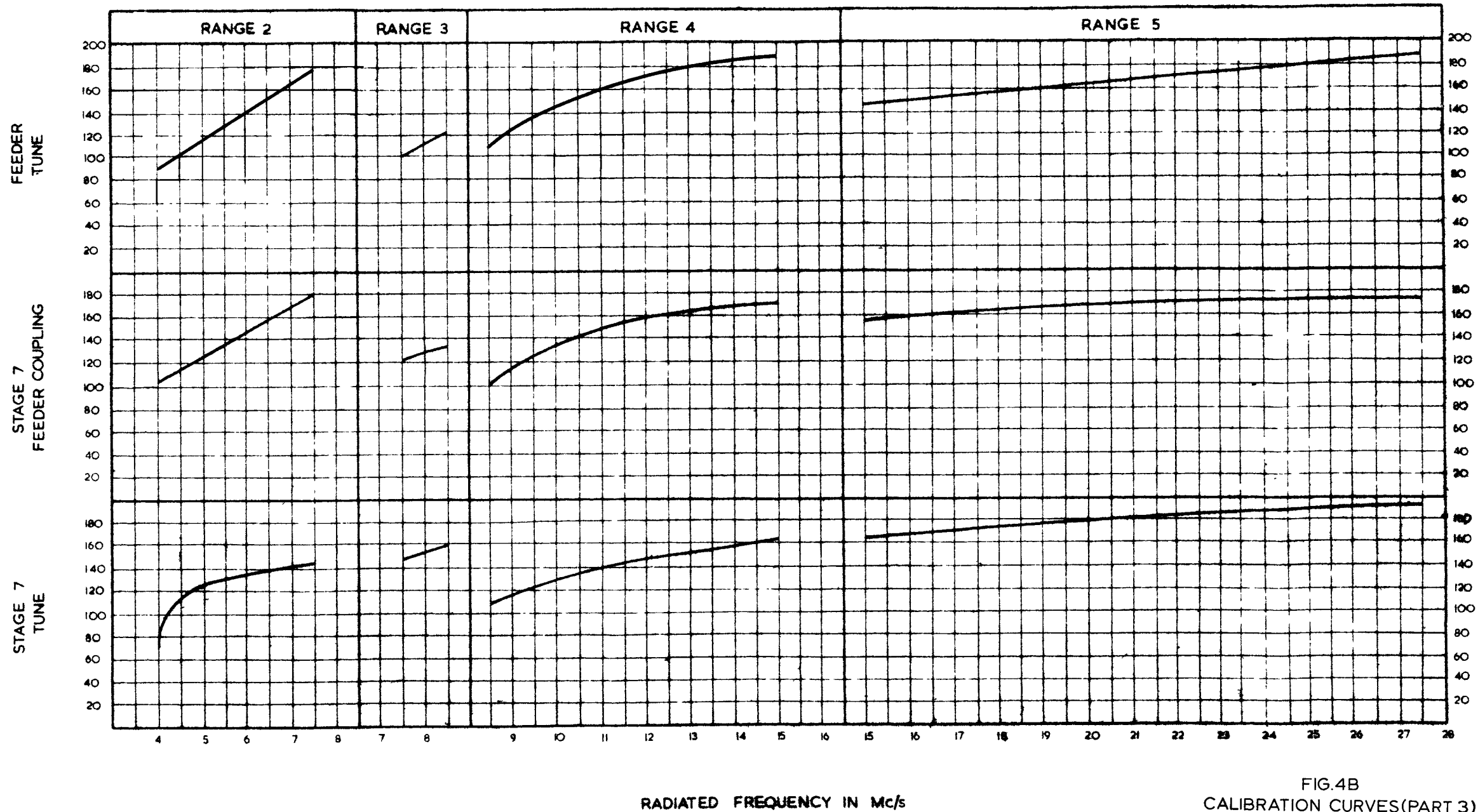
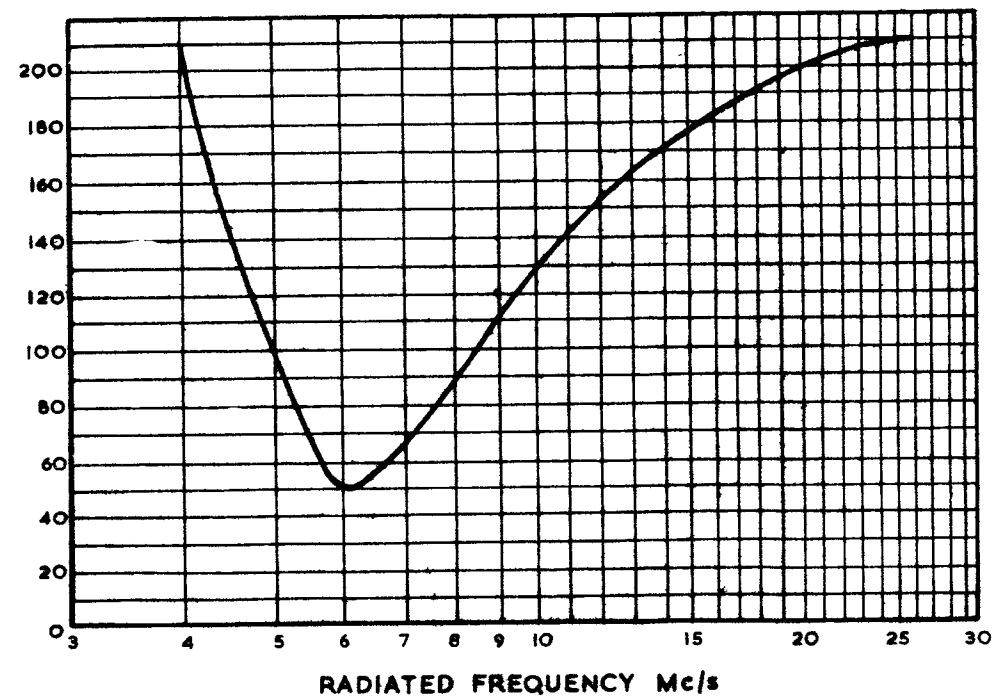

RADIATED FREQUENCY IN Mc/s

FIG.4B
CALIBRATION CURVES(PART 3)
TRANSMITTER TYPE HS71/1
WZ.28345/D SH.3.

NOTE : USE FIG.5
OPPOSITE, BUT
SUBSTITUTE THESE
THREE COLUMNS
FOR THE THREE
R.H. COLUMNS
OF FIG. 5

MEAN P/O KW	P.E.P KW	FEEDER INDICATOR
4.7	9.4	NOT APPLIC- ABLE TO HS71/1
7.3		
0		
4.7	9.4	
7.2		
0		
4.7	9.4	
7.0		
0		
4.65	9.3	
7.2		
0		
4.6	9.2	
7.3		
0		

TYPICAL POWER FIGURES, HS. 71/1
(PART OF WZ.28248/D SH.1)

TYPE OF EMISSION	RADIATED FREQ. Mc/s	O.S.C. FREQ. Mc/s	HG.1(V1) 1c mA	HG.2(V2) 1c mA	HG.3(V3) 1c mA	AMP. (V4) 1c mA	AMP. V5/6		Monitor		MIXER(V7/8) 1c mA	ST1(V9) 1c mA	ST2(V10) 1c mA	ST3(V11) 1c mA	ST4 Eg V	ST4 1a mA	ST5 Eg V	ST5 1c mA	ST6 1g mA	ST6 1c A	ST7 1g mA	ST7 1c A	HT KV	AC CURRENT	MEAN P/O	P.E.P KW	FEEDER INDICATOR
							1g	1c	V12 1c mA	V13 1c mA																	
2T	4.0	3.55	1.3	1.6	1.4	5.3	1.2	18	7	16	11	6.7	40	25	1.5	88	30	100	37	.52	280	2.7	4.1	25		9.4	600
CW	4.0	3.55	1.3	1.6	1.4	5.0	1.2	18	7	16	11	6.7	40	25	2.5	90	45	100	50	.65	500	3.25	4.05	27.5	7.3		820
			1.3	1.6	1.4	5.0	1.3	18	7	16	11	6.7	40	25	0	90	0	60	0	.32	0	.7	4.05	12.0	0		0
2T	10.0	6.55	1.4	4.6	1.4	4.0	0.6	14	7	16	11	6.8	40	25	1.3	90	35	85	40	.53	250	2.65	4.05	25		9.4	520
CW	10.0	6.55	1.4	4.6	1.4	4.0	0.5	14	7	16	11	6.7	40	26	2.2	88	40	70	50	.68	500	3.20	4.05	27.5	7.2		770
			1.4	4.6	1.4	4.0	0.5	14	7	16	11	6.7	40	25	0	90	0	60	0	.32	0	.7	4.1	12.5	0		0
2T	16.9	6.9	1.3	3.7	1.4	3.0	0.4	14	7	16	11	6.7	40	25	1.3	90	30	80	35	.55	260	2.65	4.1	25		9.4	440
	16.9	6.9	1.3	3.2	1.4	3.0	0.4	14	7	16	11	6.8	40	25	2	88	40	85	55	.7	500	3.25	4.05	27	7.0		620
			1.3	3.2	1.4	3.0	0.4	14	7	16	11	6.8	40	25	0	90	0	60	0	.32	0	.7	4.1	12.2	0		0
2T	21	4.475	1.3	2.7	3.9	5.3	0.8	15	7	16	11	6.7	39	25	1.9	87	34	95	40	.55	280	2.6	4.05	26		9.3	410
CW	21	4.475	1.3	2.7	3.9	5.3	0.8	15	7	16	11	6.7	40	25	2.5	87	43	95	60	.6	500	3.2	4.1	27	7.2		580
			1.3	2.7	3.9	5.3	0.8	15	7	16	11	6.7	40	25	0	88	0	60	0	.32	0	.7	4.05	12.3	0		0
2T	27.5	6.1	2.0	4.4	4.5	5.5	1.6	18	7	16	11	6.6	39	26	2.4	88	40	110	35	.6	280	2.65	4.05	27		9.2	450
CW	27.5	6.1	2.1	3.5	4.6	5.6	1.6	18	7	16	11	6.8	39	26	3.4	90	54	140	60	.7	500	3.25	4.05	28	7.3		610
			2.1	3.5	4.6	5.6	1.6	18	7	16	11	6.8	40	25	0	90	0	60	0	.32	0	.7	4.05	12.4	0		0

NOTE: -

These figures are approximate and the Mixer Unit figures, in particular, may vary considerably with each transmitter.

TRANSMITTER TYPE HS71, TYPICAL POWER FIGURES
WZ.15044/D Sh.1 Iss.2

FREQUENCY BAND	RADIATED FREQUENCY Mc/s	Osc. FREQ Mc/s	TYPE OF EMISSION	HG / MIXER UNIT.												ST. 4 \hat{V}_g VOLTS	ST. 4 I_a mA	ST. 5 \hat{V}_g VOLTS	ST. 5 I_c mA	ST. 6 I_g mA	ST. 6 I_c A	ST. 7 I_g mA	ST. 7 I_c A	HT. kV	AC. CURRENT A	MEAN OUTPUT POWER kW	P.E.P. kW	FEEDER INDICATOR	
				V1 I_c mA	V2 I_c mA	V3 I_c mA	V4 I_c mA	V5/6 I_g mA	V5/6 I_c mA	V7/8 I_c mA	V9 I_c mA	V10 I_c mA	V11 I_c mA	V12 I_c mA	V13 I_c mA														
2.5 TO 5.5 Mc/s	2.5	4.65	CW	2.0	1.8	1.5	5.5	0.5	12	12	6.7	4.0	26	7	15	2.0	88	51	140	36	0.6	460	3.2	4.0	26	7.4		780	
			TWO TONE	2.0	1.8	1.5	5.5	0.5	14	12	6.7	4.0	26	7	15	1.6	88	4.0	120	30	0.5	250	2.6	4.0	22		9.5	580	
	3.5	5.65	CW	2.0	2.0	1.5	5.2	1.2	17	12	6.8	4.0	26	7	15	2.0	88	52	140	42	0.65	460	3.2	4.0	26	7.7		790	
			TWO TONE	2.0	2.0	1.5	5.0	1.2	16	12	6.8	4.0	26	7	15	1.5	88	38	120	30	0.6	250	2.6	4.0	23		9.7	590	
	4.5	6.65	CW	2.0	2.0	1.5	5.1	1.3	16	12	6.7	4.0	26	7	15	2.5	88	50	140	44	0.7	460	3.2	4.0	26	7.7		790	
			TWO TONE	2.0	2.0	1.5	5.0	1.3	16	12	6.7	4.0	26	7	15	1.8	88	42	115	32	0.7	250	2.6	4.0	23		9.7	590	
	5.5	3.825	CW	2.0	2.0	1.5	5.0	1.3	17	12	6.7	4.0	26	7	15	2.3	88	52	140	47	0.65	460	3.2	4.0	26	7.6		780	
			TWO TONE	2.0	2.0	1.5	5.0	1.3	17	12	6.7	4.0	26	7	15	1.7	87	40	118	30	0.55	250	2.6	4.0	23		9.8	580	
	3.5 TO 20 Mc/s	3.5	5.65	CW	2.0	1.8	1.5	4.2	0.9	16	12	7	4.0	26	7	15	2.1	88	40	100	40	0.7	460	3.2	4.0	26	7.5		780
				TWO TONE	2.0	1.8	1.5	4.2	0.9	16	12	7	4.0	26	7	15	1.6	88	34	80	28	0.6	250	2.6	4.0	23		9.7	580
8.0		5.075	CW	2.0	4.4	1.6	3.1	0.7	14	12	7	4.0	26	7	15	2.1	88	38	93	40	0.6	460	3.2	4.0	26	7.7		790	
			TWO TONE	2.0	4.4	1.6	3.1	0.7	14	12	7	4.0	26	7	15	1.7	88	32	82	29	0.55	240	2.6	4.0	23		9.8	570	
12.0		4.925	CW	2.0	2.5	1.5	4.5	0.3	12	12	7	4.0	26	7	15	2.1	88	37	85	45	0.6	460	3.2	4.0	26	7.6		770	
			TWO TONE	2.0	2.5	1.5	4.5	0.3	12	12	7	4.0	26	7	15	1.6	88	28	80	32	0.5	240	2.6	4.0	23		9.8	570	
16.5		3.5975	CW	2.0	4.2	1.5	3.1	0.5	14	12	7	4.0	26	7	15	2.5	88	47	120	50	0.75	460	3.2	4.0	26	7.8		750	
			TWO TONE	2.0	4.2	1.5	3.1	0.5	14	12	7	4.0	26	7	15	1.9	88	38	108	34	0.65	240	2.6	4.0	23		9.9	550	
20.0		4.4625	CW	2.0	4.3	3.0	5.0	0.6	14	12	7	4.0	26	7	15	2.4	88	47	120	50	0.7	460	3.2	4.0	26	7.7		700	
			TWO TONE	2.0	3.0	3.0	4.5	0.6	14	12	7	4.0	26	7	15	1.9	88	36	105	36	0.5	230	2.6	4.0	23		9.9	500	
SPACE				2.0	2.0	1.5	5.2	1.0	16	12	6.7	4.0	26	7	15	0	90	0	60	0	0.32	0	0.7	4.1	12	0	0	0	

NOTE:- THESE FIGURES ARE APPROXIMATE AND THE MIXER UNIT FIGURES, IN PARTICULAR, MAY VARY CONSIDERABLY WITH EACH TRANSMITTER.

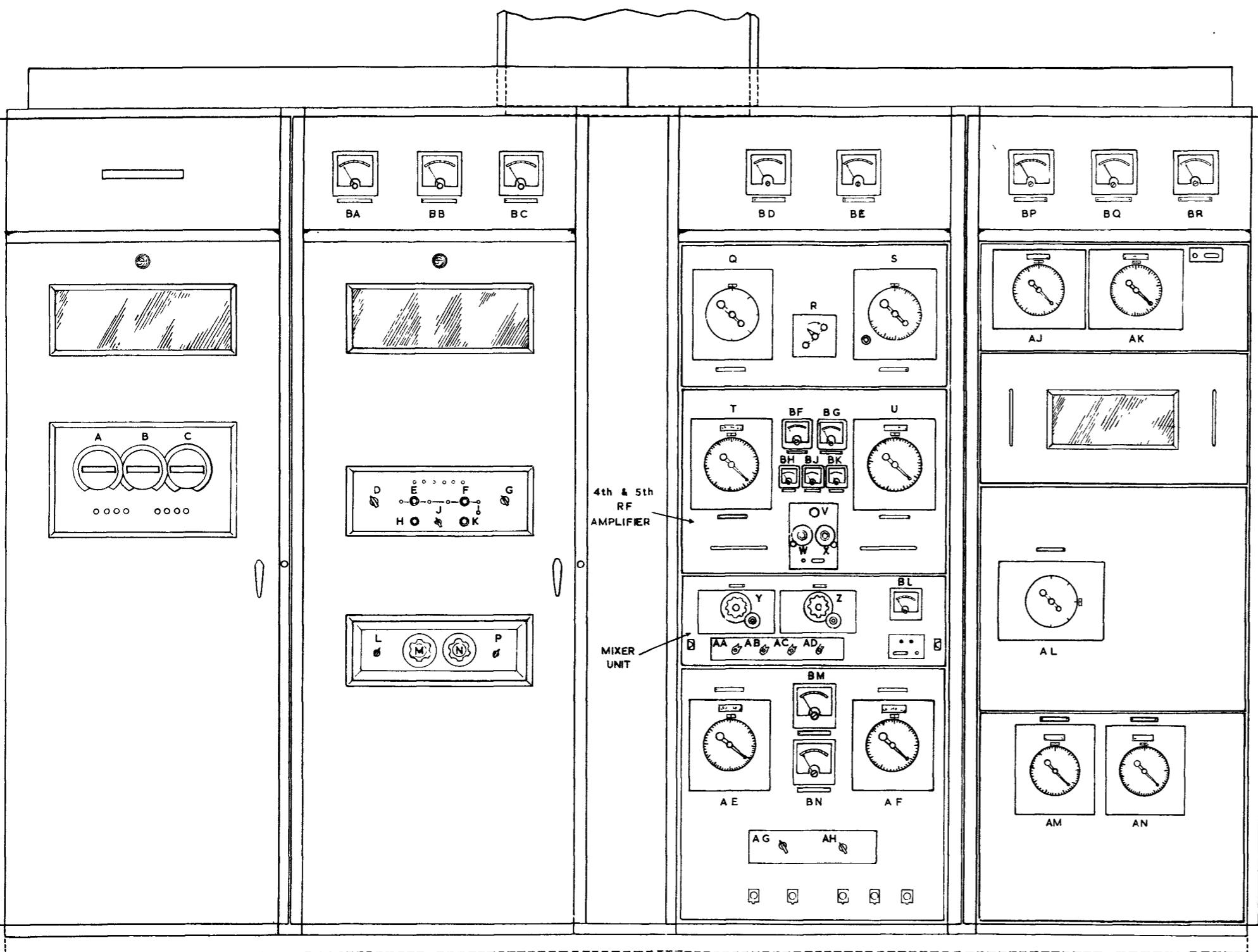

RECTIFIER & CONTROL UNIT

RADIO FREQUENCY UNIT

TRANSMITTER TYPE HS71 CONTROL LAYOUT
(WZ. 18301/D Sh. 1 Iss. 2)

CONTROLS		METERS	
REF	TITLE	REF	TITLE
A	HT INTERLOCK control	BA	AC VOLTS
B	HT EARTHING control	BB	AC AMPS
C	MAINS ISOLATOR CONTROL	BC	HT VOLTS
D	AUTO-MANUAL switch	BD	STAGE 6 GRID CURRENT
E	START switch	BE	STAGE 6 CATHODE CURRENT
F	HT ON switch	BF	ST 5 CATHODE CURRENT
G	FREQUENCY switch	BG	ST 4 ANODE CURRENT
H	STOP switch	BH	ST.5 GRID PEAK VOLTS
J	LOCAL / REMOTE switch	BJ	ST 5 GRID CURRENT
K	OFF & ON switch	BK	ST.4 GRID PEAK VOLTS
L	AC VOLTMETER switch	BL	MIXER METERING
M	STAGE 5,6 & RECT. FILS rheostat	BM	FIL VOLTMETER
N	STAGE 7 FILS. rheostat	BN	AUX VOLTMETER
P	HT VOLTS switch	BP	ST 7 GRID CURRENT
Q	RANGE control MH7	BQ	ST.7 CATHODE CURRENT
R	ST. 5 HT INTERLOCK switch	BR	FEEDER INDICATOR
S	OUTPUT TUNE control (MH8)		
T	ST 5 TUNE control (MH4)		
U	ST 4 TUNE control (MH3)		
V	NEUTRALISING		
W	FEEDBACK control		
X	EXT. DRIVE control		
Y	HG TUNE control (MH1)		
Z	MIXER TUNE control (MH2)		
AA	1HG Mc/s range switch		
AB	HG METERING switch		
AC	MIXER & MONITOR METERING switch		
AD	1RAD Mc/s range switch		
AE	ST. 6 COUPLING control (MH5)		
AF	ST 6 TUNE control (MH6)		
AG	FIL VOLTMETER switch		
AH	AUX VOLTMETER switch		
AJ	ST. 7 INPUT TUNE control (MH11)		
AK	FEEDER TUNE control (MH13)		
AL	ST. 7 & OUTPUT RANGE switch (MH12)		
AM	ST 7 TUNE control MH9		
AN	FEEDER COUPLING control (MH10)		

FIG. 6

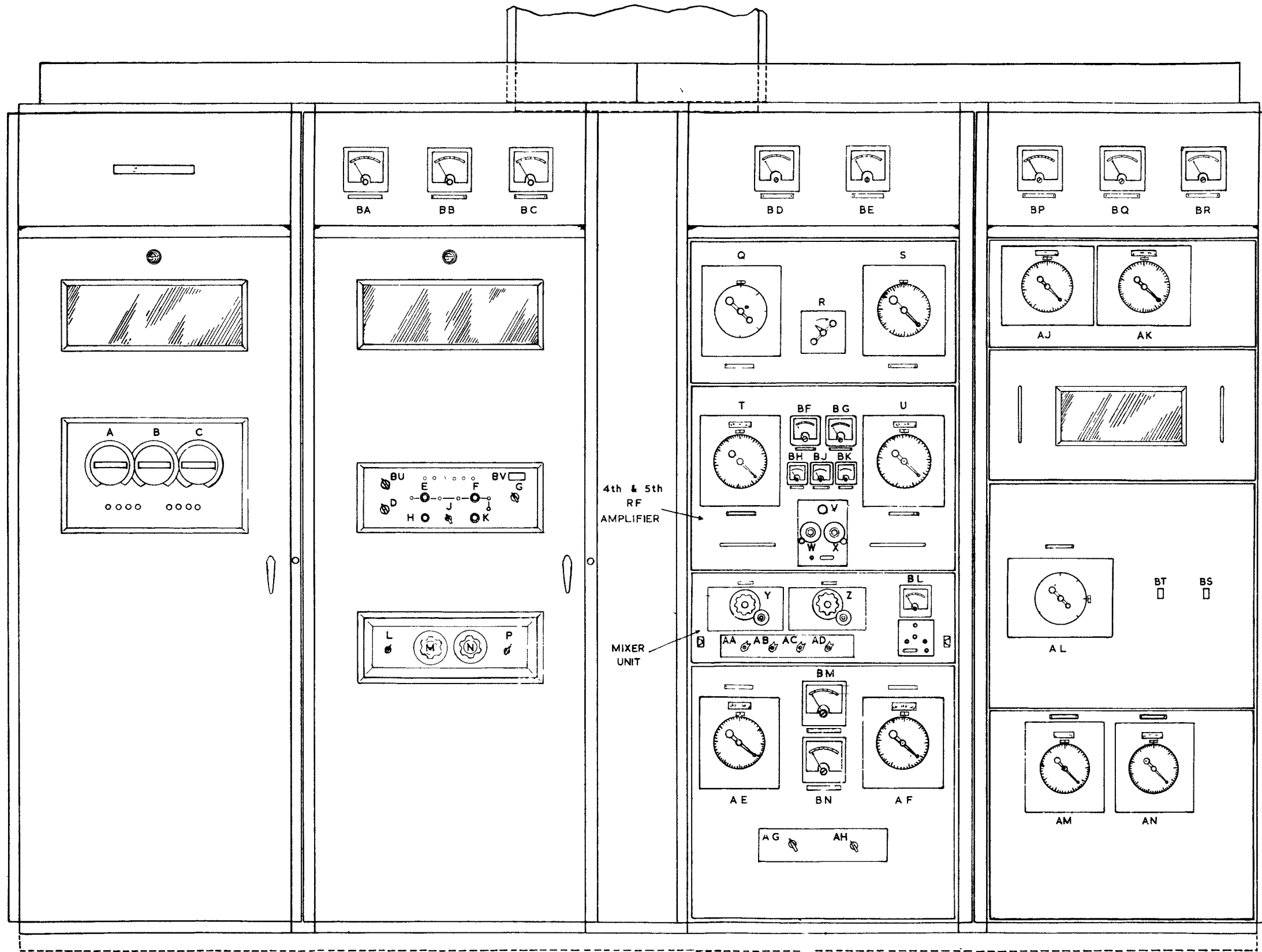

RECTIFIER & CONTROL UNIT

RADIO FREQUENCY UNIT

CONTROLS		& METERS	
REF	TITLE	REF	TITLE
A	HT INTERLOCK control	BA	AC VOLTS
B	HT EARTHING control	BE	AC AMPS
C	MAINS ISOLATOR CONTROL	BC	HT VOLTS
D	AUTO-MANUAL switch	BD	STAGE 6 GRID CURRENT
E	START switch	BE	STAGE 6 CATHODE CURRENT
F	HT ON switch	BF	ST 5 CATHODE CURRENT
G	FREQUENCY switch	BG	ST 4 ANODE CURRENT
H	STOP switch	BH	ST.5 GRID PEAK VOLTS
J	LOCAL / REMOTE switch	BJ	ST.5 GRID CURRENT
K	OFF & RESET switch	BK	ST.4 GRID PEAK VOLTS
L	AC. VOLTMETER switch	BL	MIXER METERING
M	STAGE 5.6 & RECT FILS rheostat	BM	FIL VOLTMETER
N	STAGE 7 FILS rheostat	BN	AUX VOLTMETER
P	HT VOLTS switch	BP	ST. 7 GRID CURRENT
Q	RANGE control	BQ	ST. 7 CATHODE CURRENT
R	ST 5 HT INTERLOCK switch	BR	FEEDER POWER METER
S	OUTPUT TUNE control	BS	POWER METER SWITCH
T	ST 5 TUNE control	BT	REFLECTOMETER TEST
U	ST 4 TUNE control	BU	GRID CURRENT TRIP LEVEL CONTROL
V	NEUTRALISING	BV	INTERLOCK TEST POINTS
W	FEEDBACK control		
X	DRIVE LEVEL control		
Y	HG TUNE control		
Z	MIXER TUNE control		
AA	1HG Mc/s range switch		
AB	HG METERING switch		
AC	MIXER & MONITOR METERING switch		
AD	1RAD Mc/s range switch		
AE	ST. 6 COUPLING control		
AF	ST 6 TUNE control		
AG	FIL. VOLTMETER switch		
AH	AUX. VOLTMETER switch		
AJ	ST. 7 INPUT TUNE control		
AK	FEEDER TUNE control		
AL	ST 7 & OUTPUT RANGE switch		
AM	ST. 7 TUNE control		
AN	FEEDER COUPLING control		

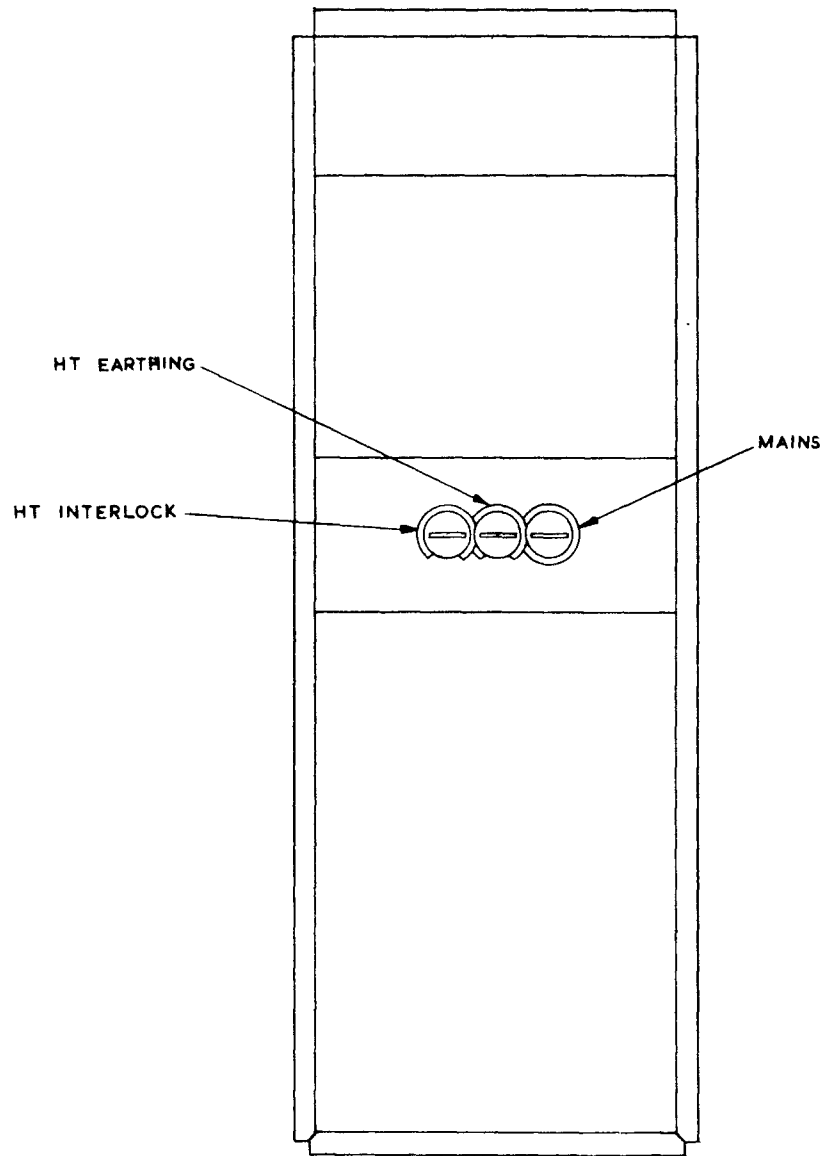

COMPONENT & CONTROL LAYOUT
 VIEW ON FRONT OF LH RECTIFIER & CONTROL UNIT
 (DOOR REMOVED)

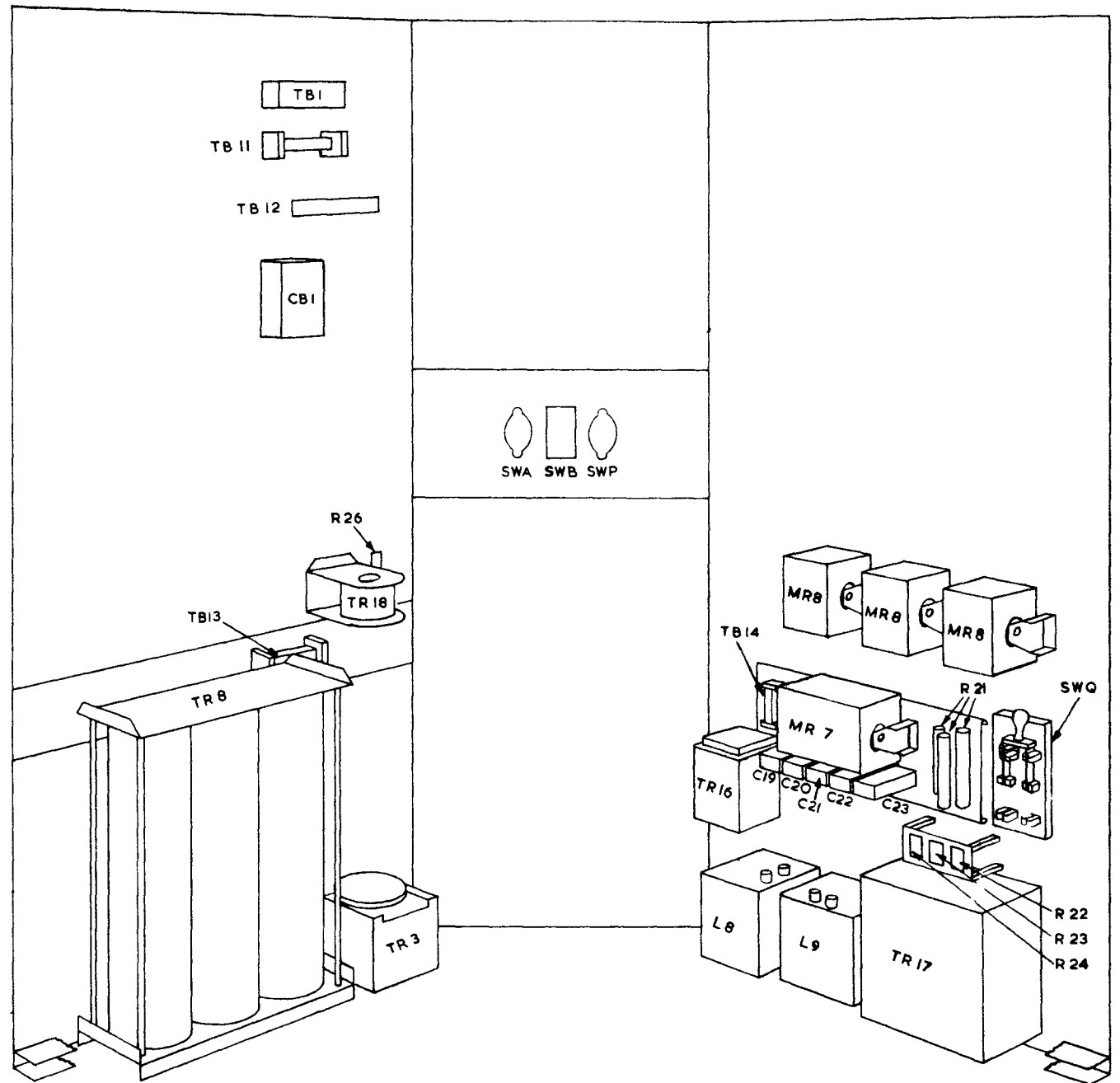

VIEW INTO CABINET FROM REAR

AP.116E-0232-1
 AL.5,MAR.'67

FIG. 7
 COMPONENT AND CONTROL LAYOUT (PART 1)
 RECTIFIER AND CONTROL UNIT (LH),
 HS71,HS71/1,HS71A
 WZ.28242/D SH.1.

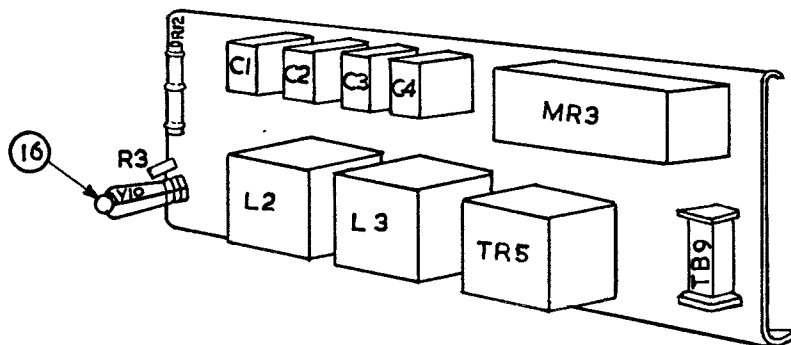
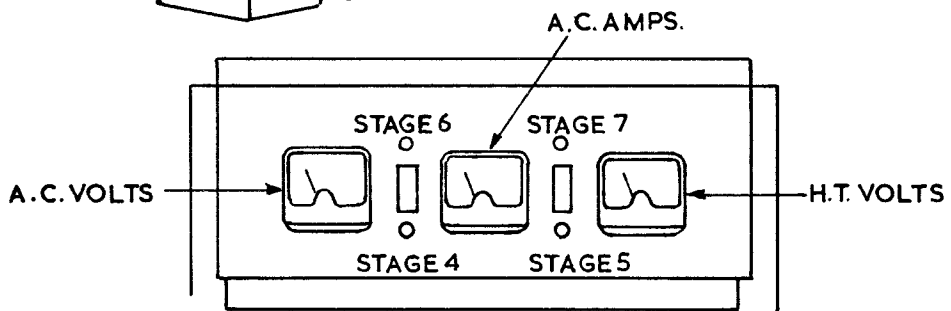
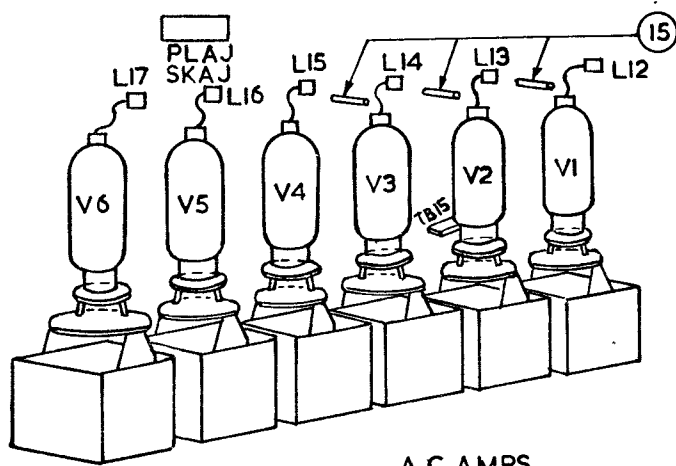
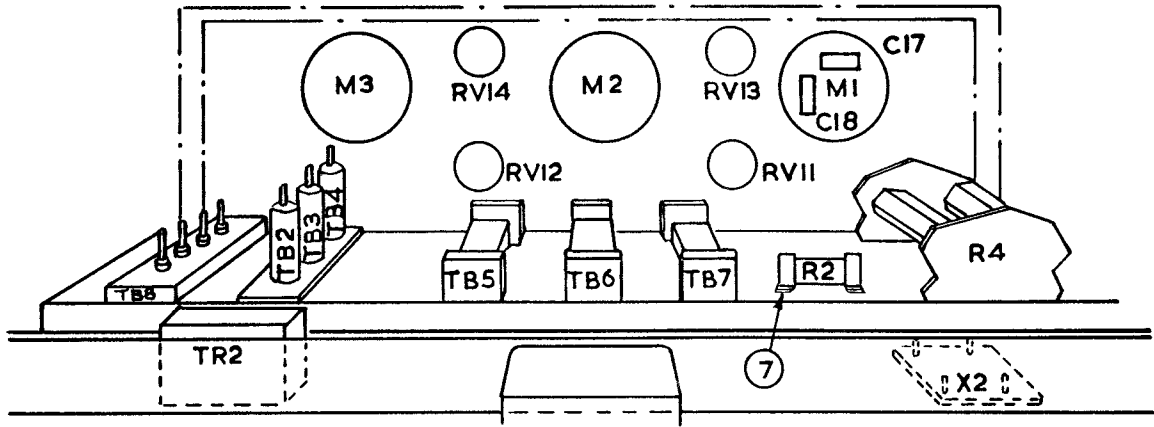

COMPONENT LAYOUT CHANGES ARISING FROM
 MODIFICATION NO. 9784
 (Fitting of Back-fire Indicators
 and Remote Bias Control)

(To face
 Fig.8)

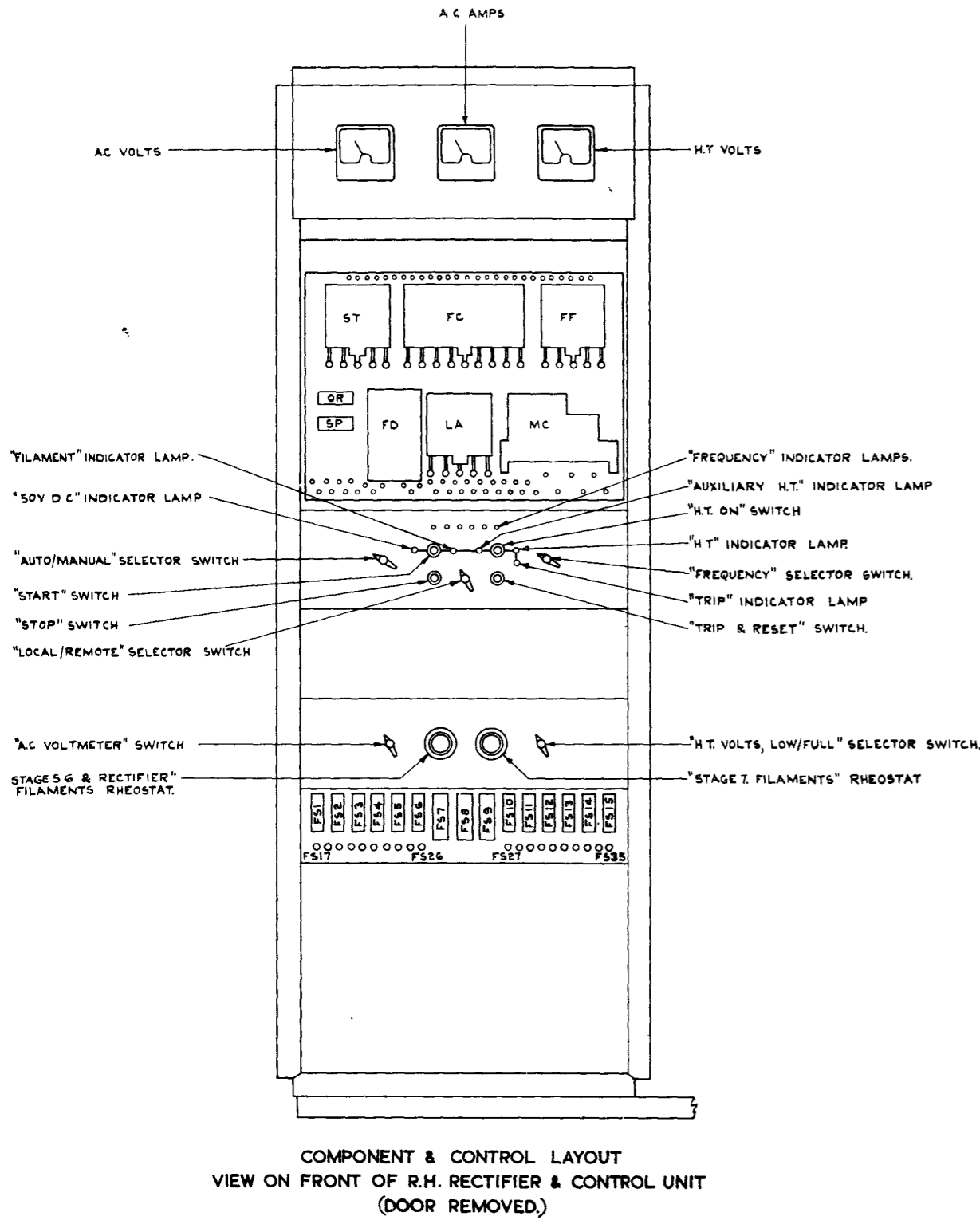

CONVENTIONS SHOWING SPRING NUMBERING & CONNECTIONS OF PLUG-IN RELAYS VIEW ON HEEL END OF RELAYS.

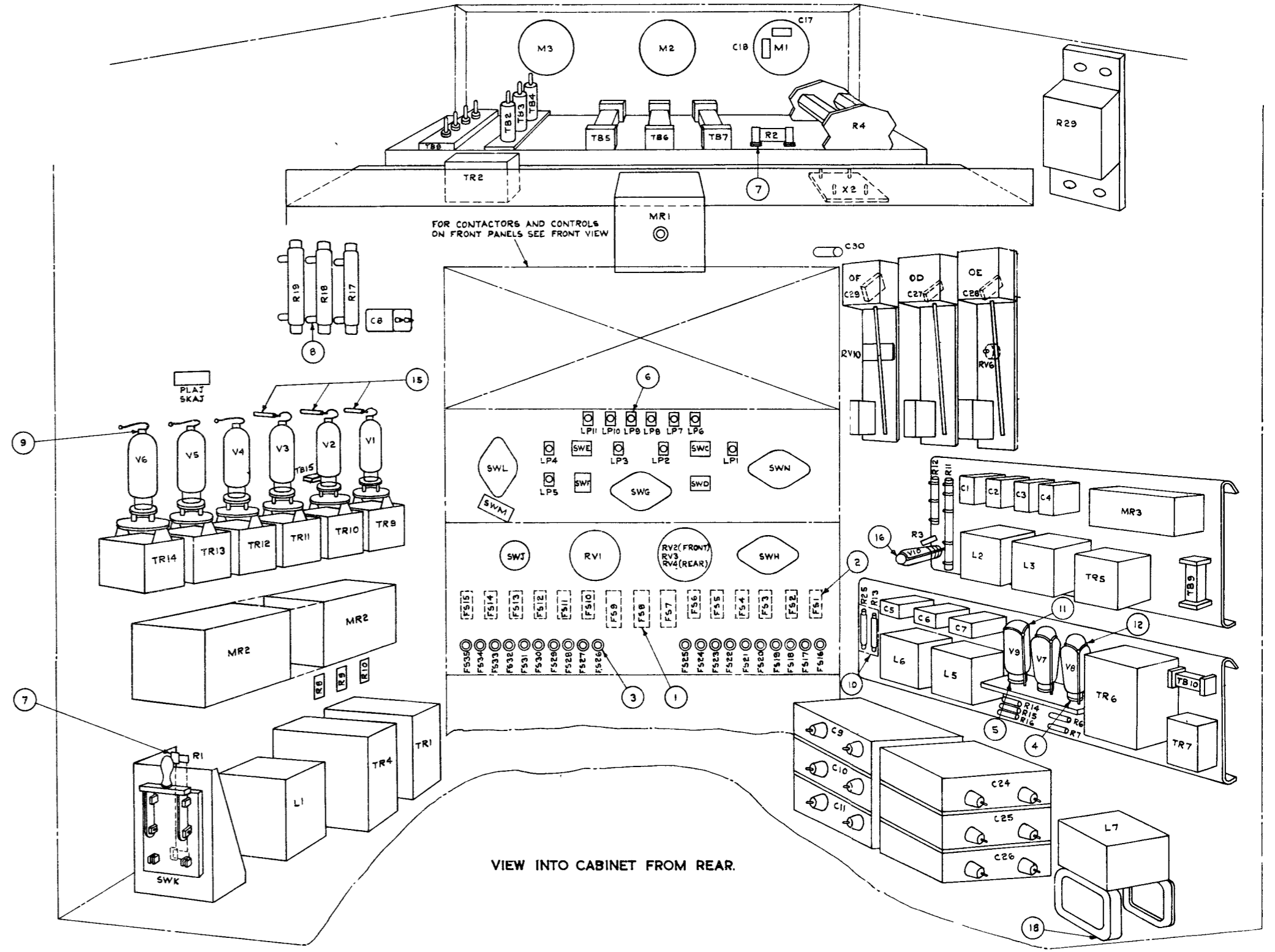
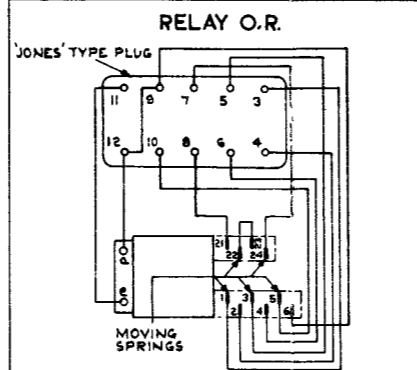
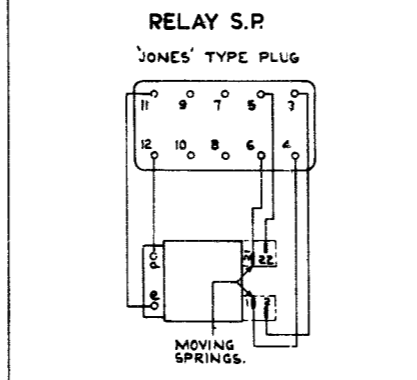

RECTIFIER AND CONTROL UNIT COMPONENT LAYOUT, PART 2 (WZ. 15037/D Sh. 2 Iss. 5)

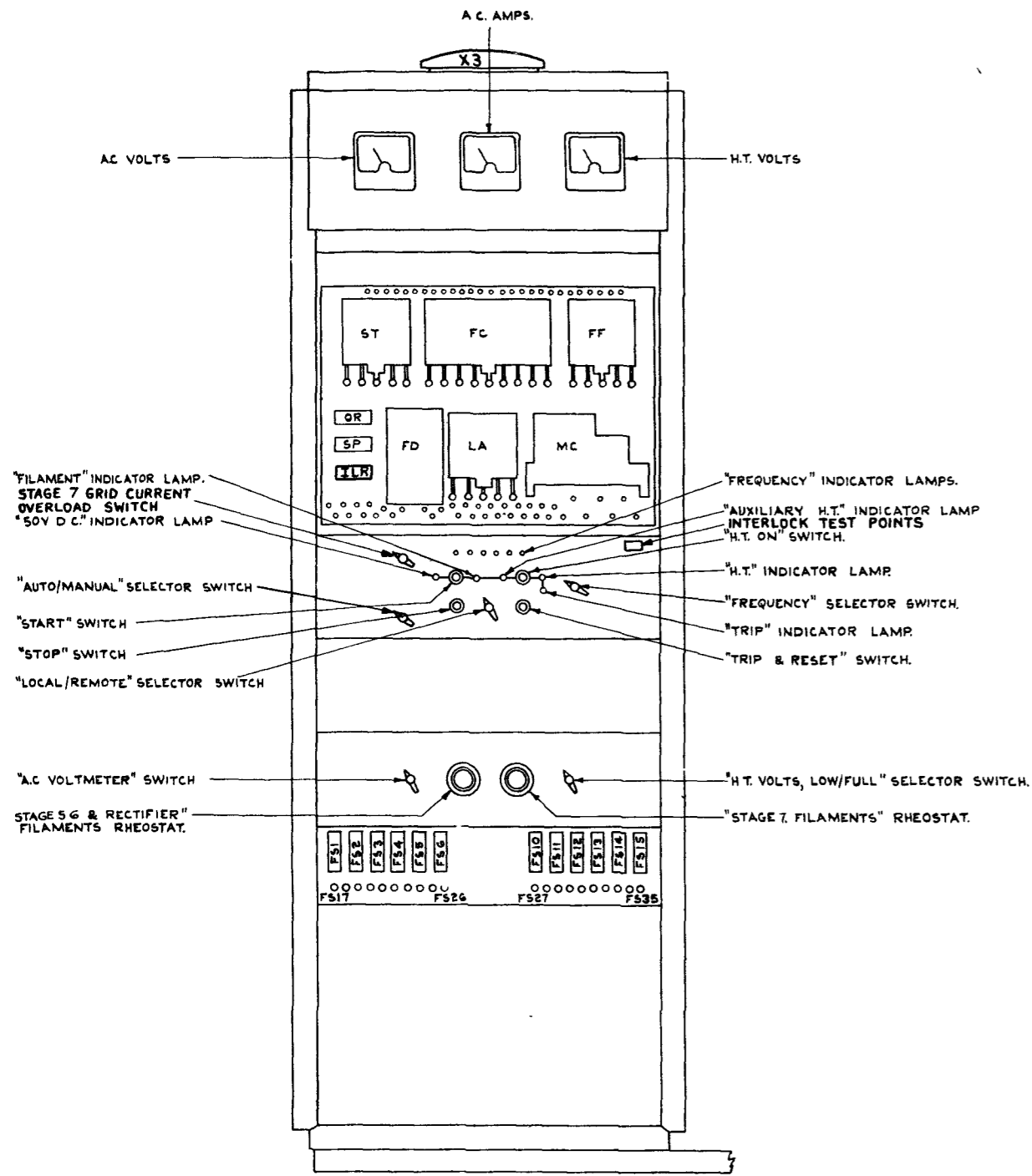

COMPONENT & CONTROL LAYOUT
VIEW ON FRONT OF R.H. RECTIFIER & CONTROL UNIT
(DOOR REMOVED)

AP.116E-0232-1
AL.5, MAR. '67

CONVENTIONS SHOWING SPRING NUMBERING & CONNECTIONS OF PLUG-IN RELAYS. VIEW ON HEEL END OF RELAYS.

RELAY ILR
"JONES" TYPE PLUG

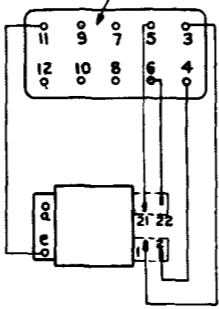

CONVENTIONS SHOWING SPRING NUMBERING & CONNECTIONS OF PLUG-IN RELAYS. VIEW ON HEEL END OF RELAYS.

RELAY S.P.
"JONES" TYPE PLUG

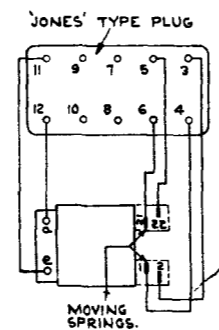

RELAY O.R.
"JONES" TYPE PLUG

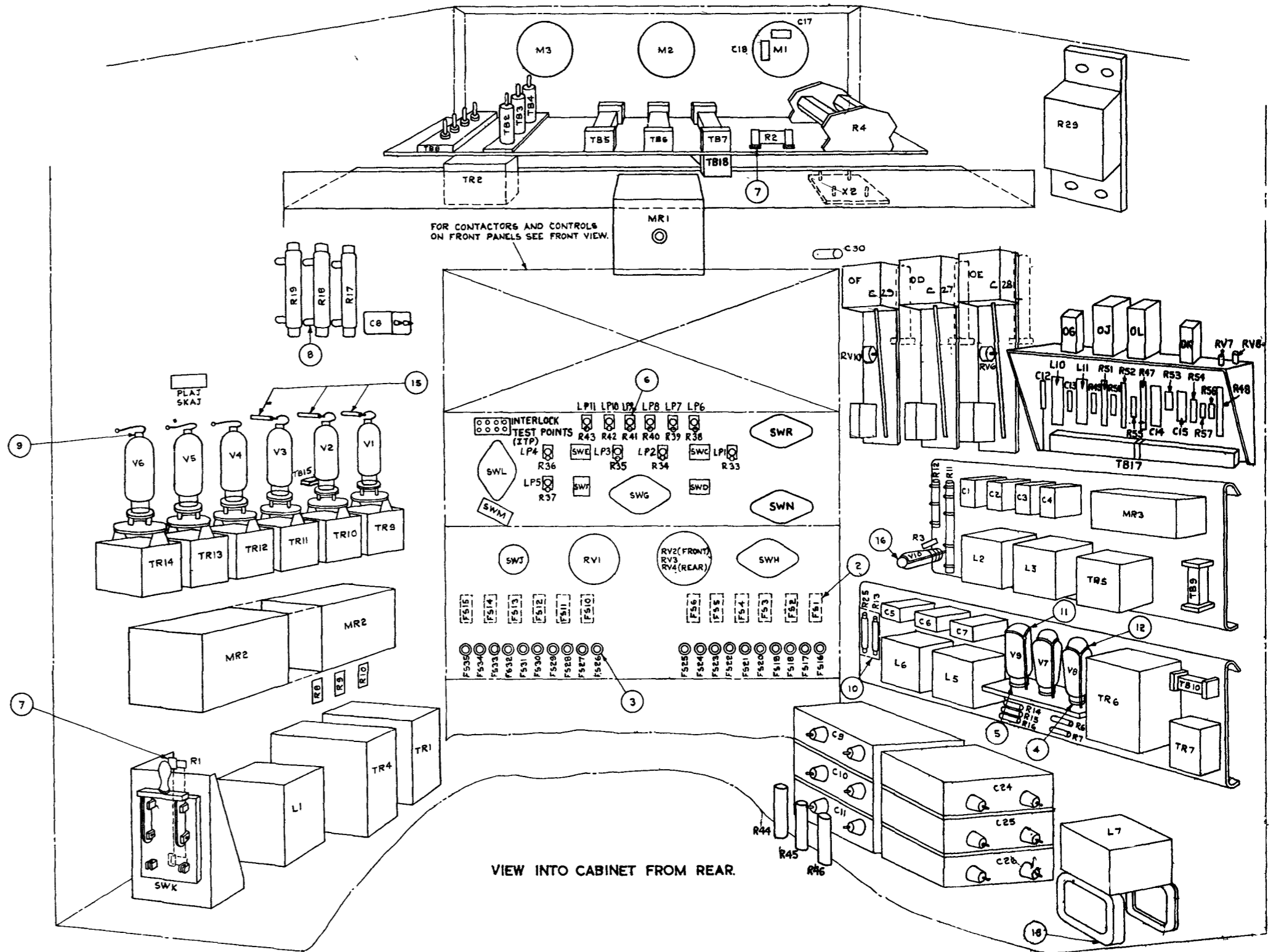
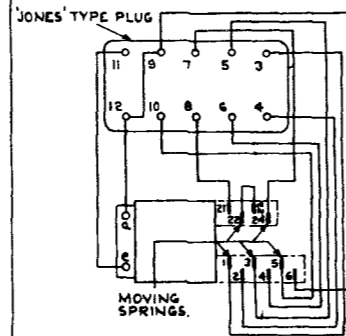

VIEW INTO CABINET FROM REAR.

FIG.8A
COMPONENT AND CONTROL LAYOUT (PART 2)
RECTIFIER AND CONTROL LAYOUT (RH), HS71/1
WZ.28242/D SH.2.

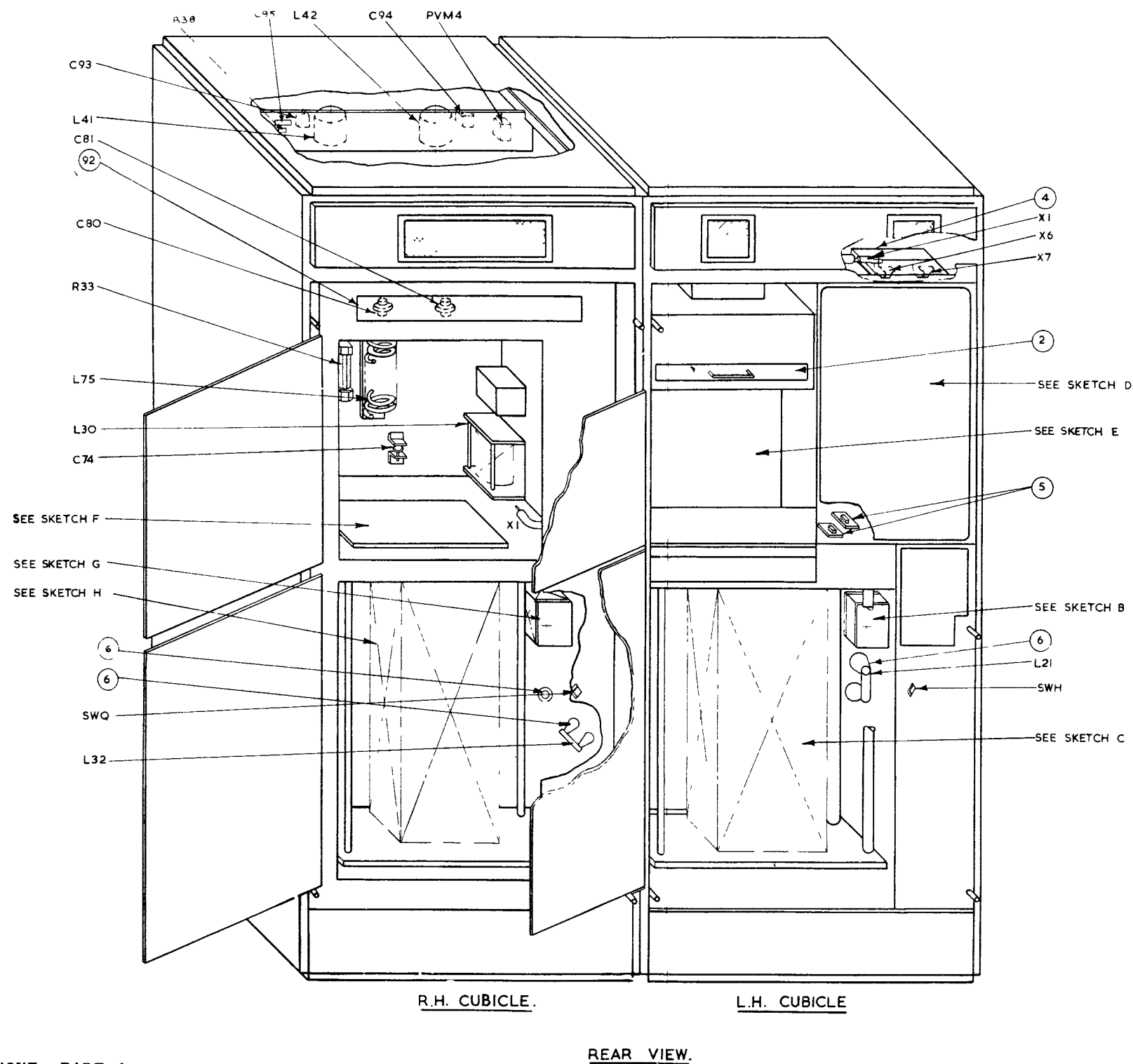
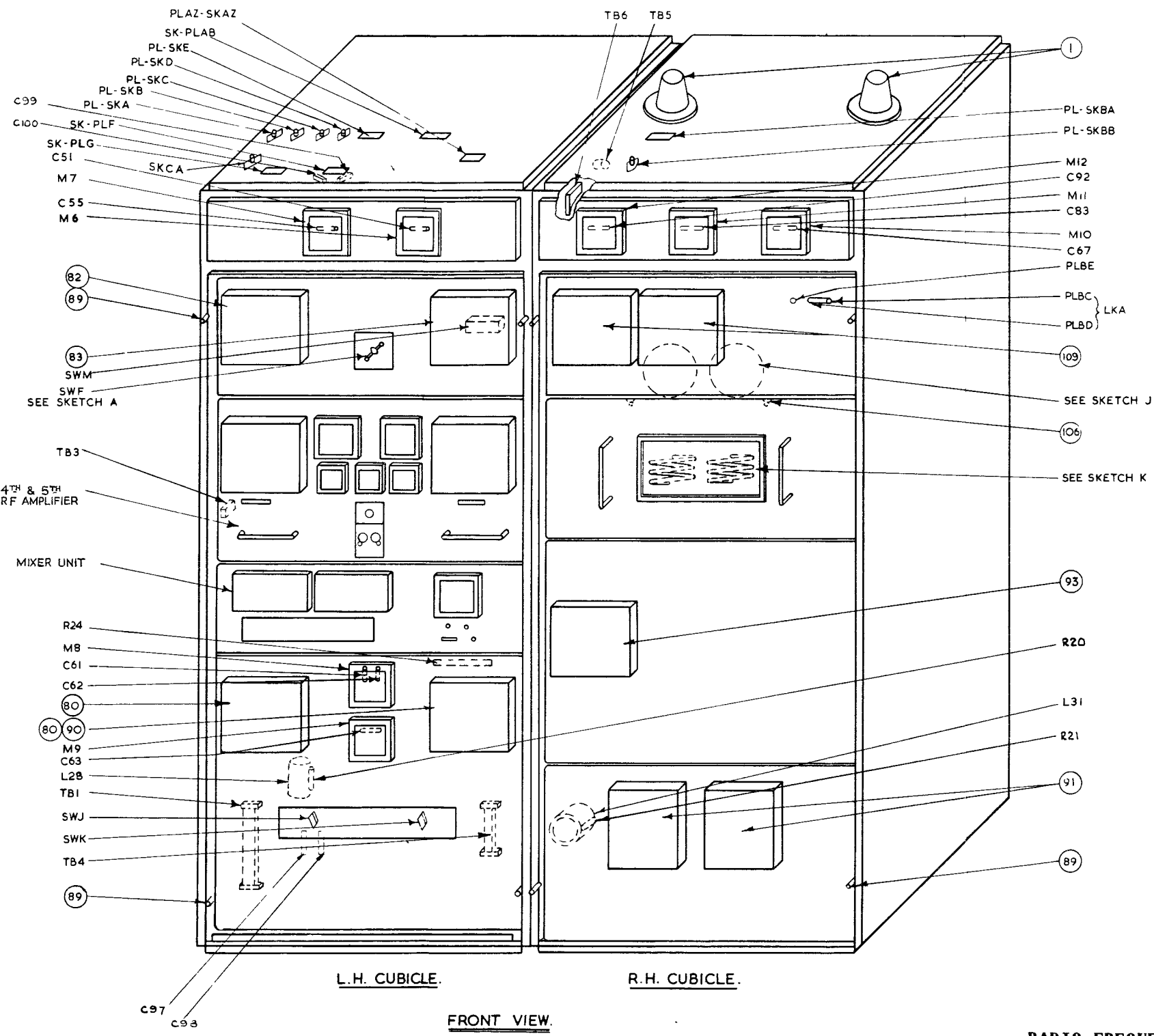

RADIO FREQUENCY UNIT COMPONENT LAYOUT, PART 1
 (WZ.15040/D Sh.1 Iss.5)

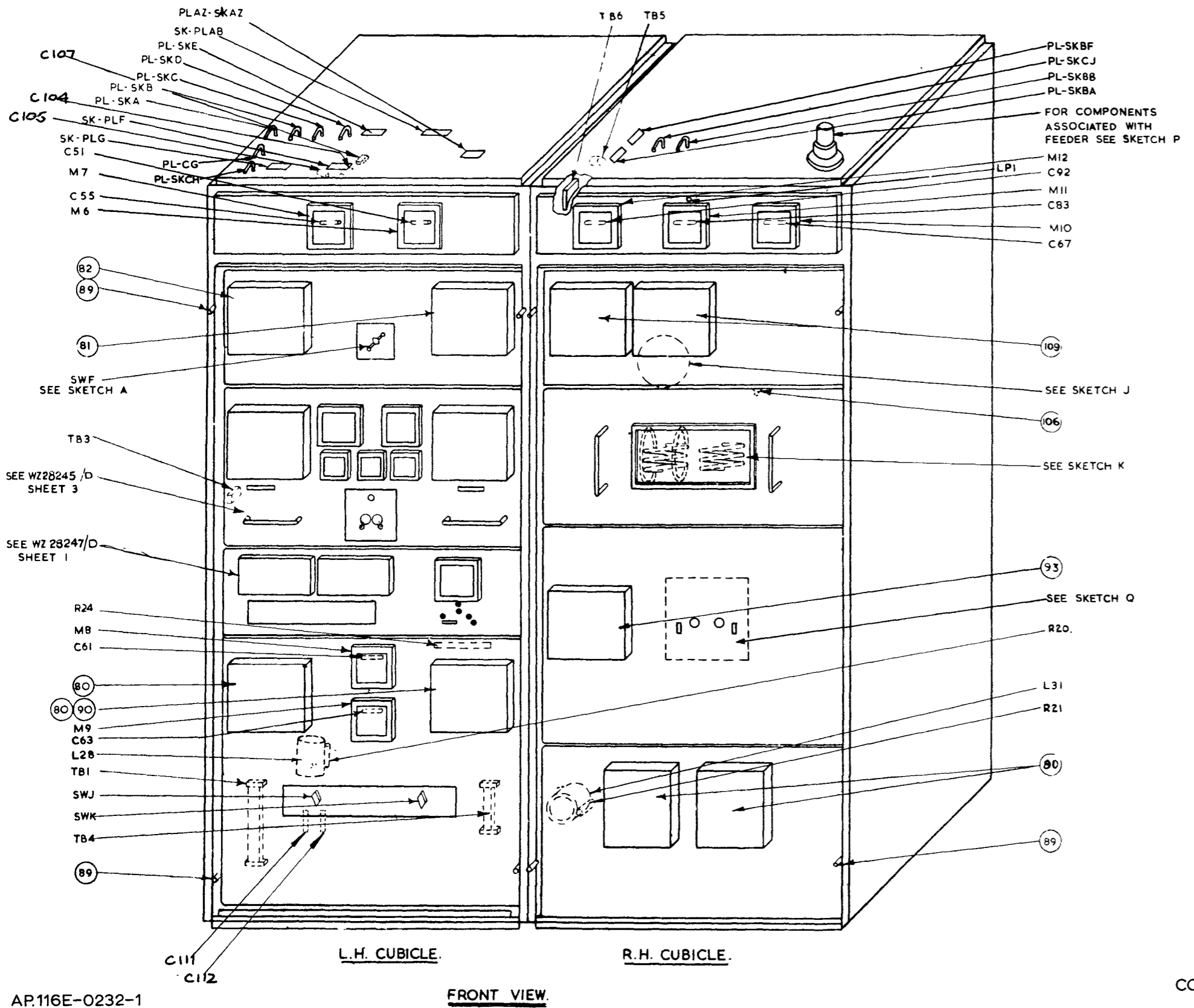

AP.116E-0232-1
AL.5, MAR. '67

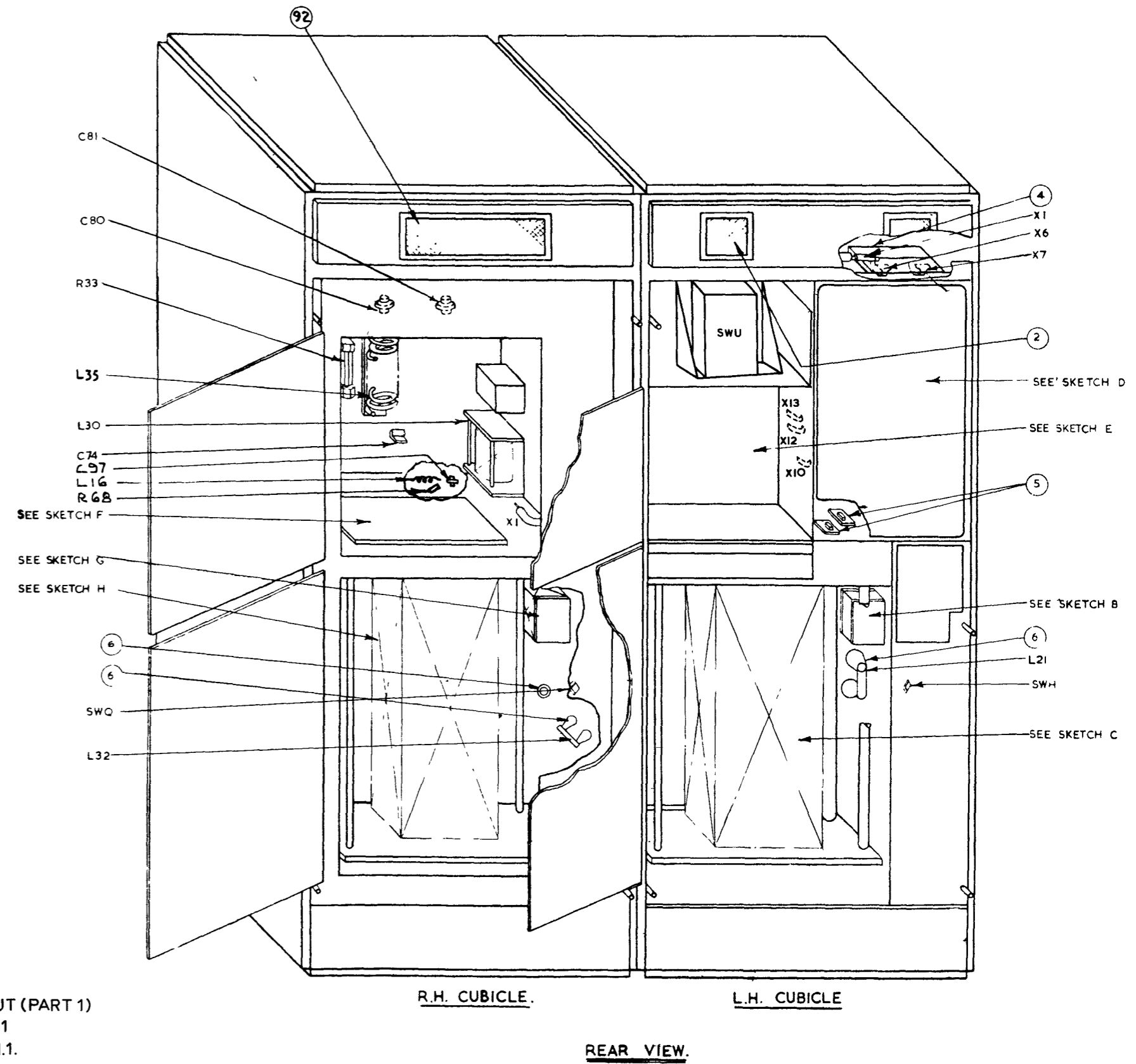
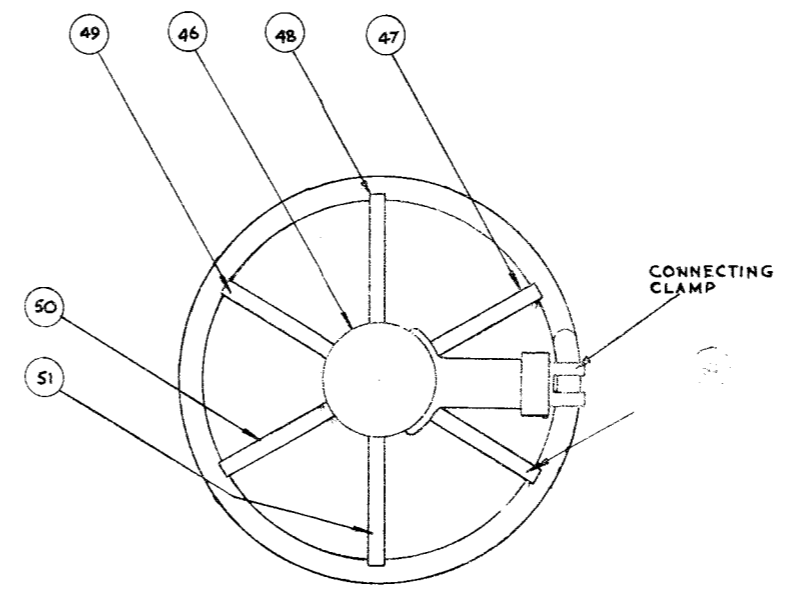
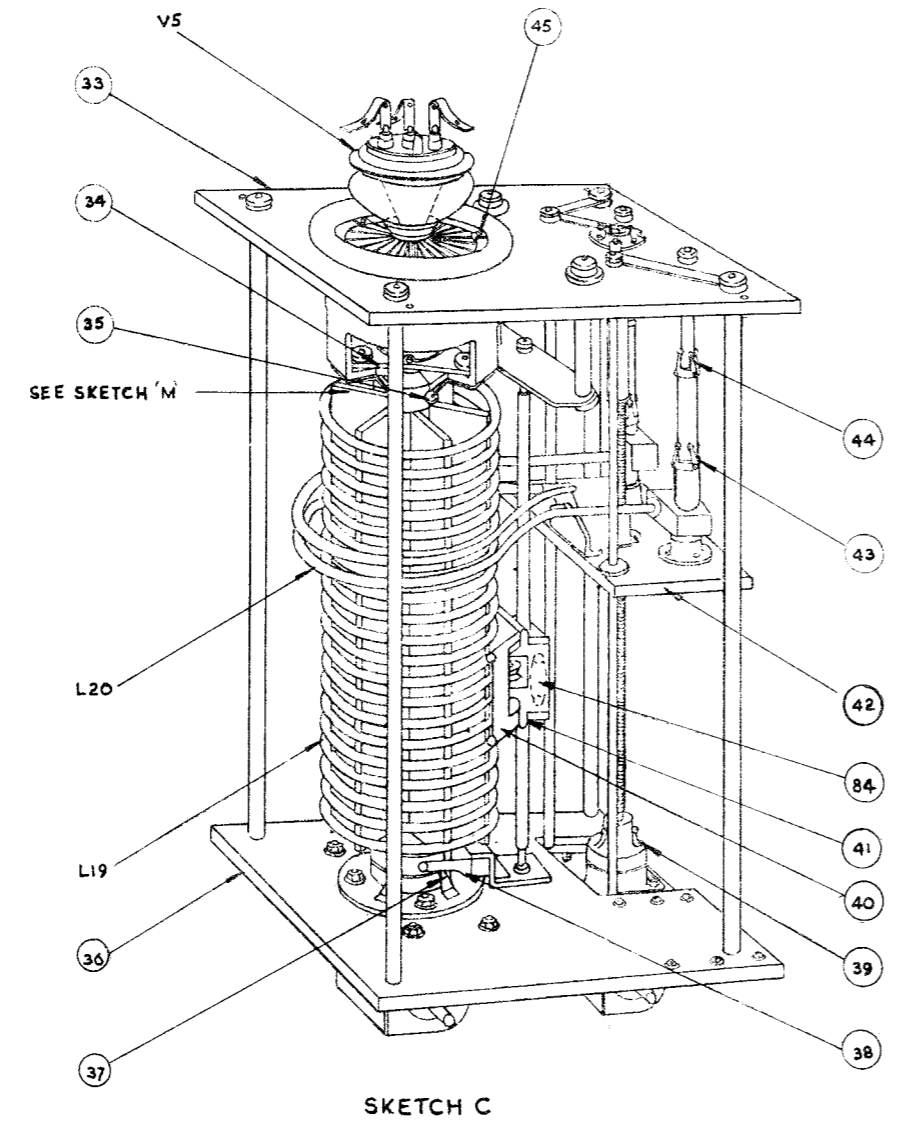
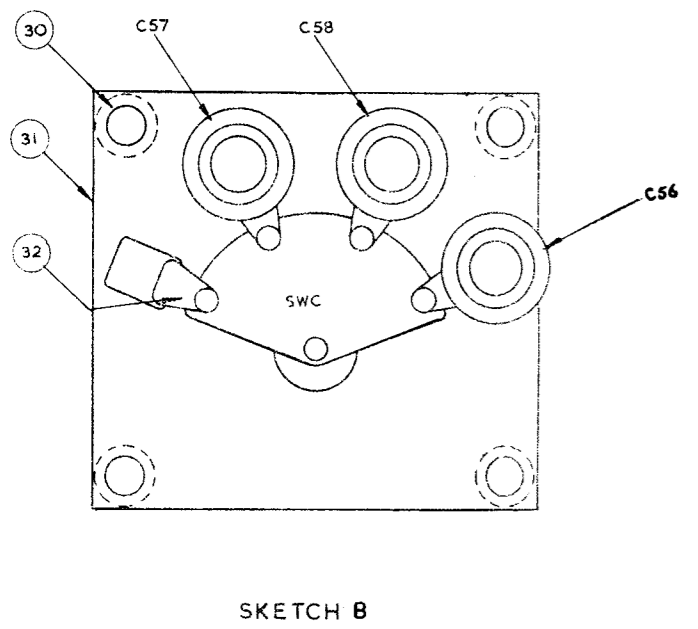
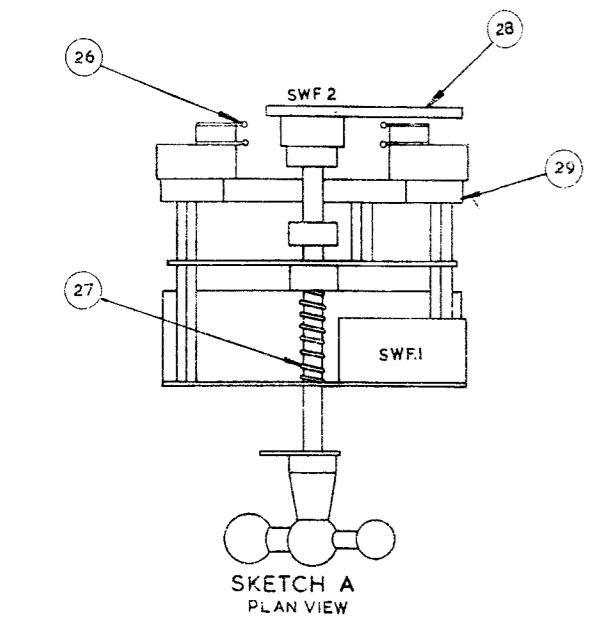
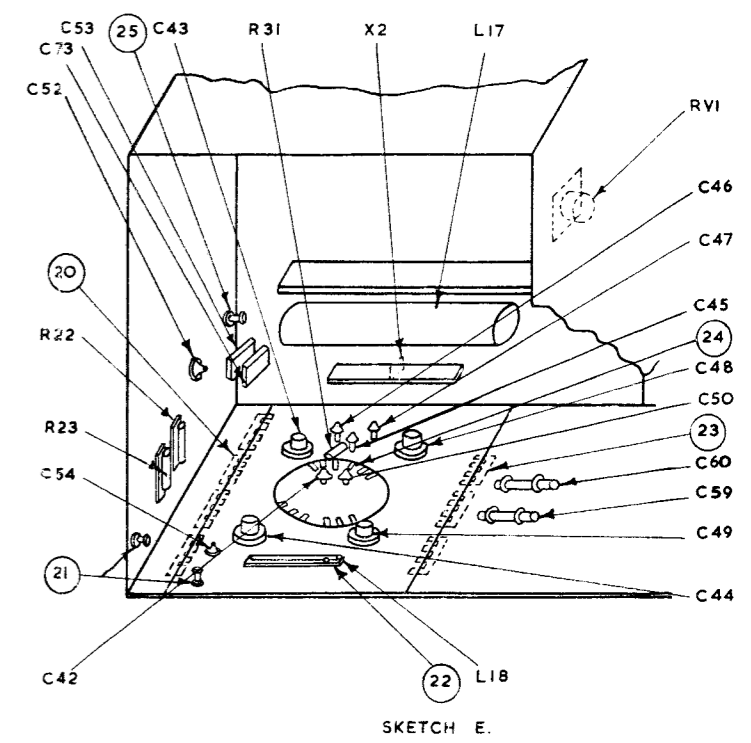
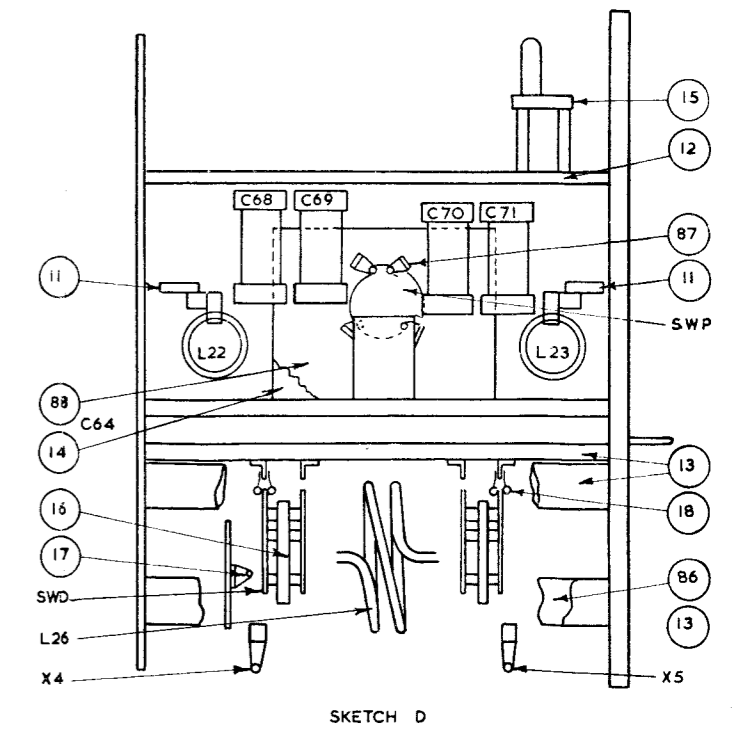

FIG. 9A
COMPONENT LAYOUT (PART 1)
R.F. UNIT, HS71/1
WZ.28245/D SH.1.

AP.116E-0232-1
AL.5, MAR. '67



SKETCH M
A VIEW LOOKING ON TOP OF THE ANODE COIL ASSEMBLY SHOWING POSITIONS OF MYCALEX COIL SUPPORTS RELATIVE TO CONNECTING CLAMP



RADIO FREQUENCY UNIT COMPONENT LAYOUT, PART
(WZ. 15040/D Sh. 2 Iss. 3)

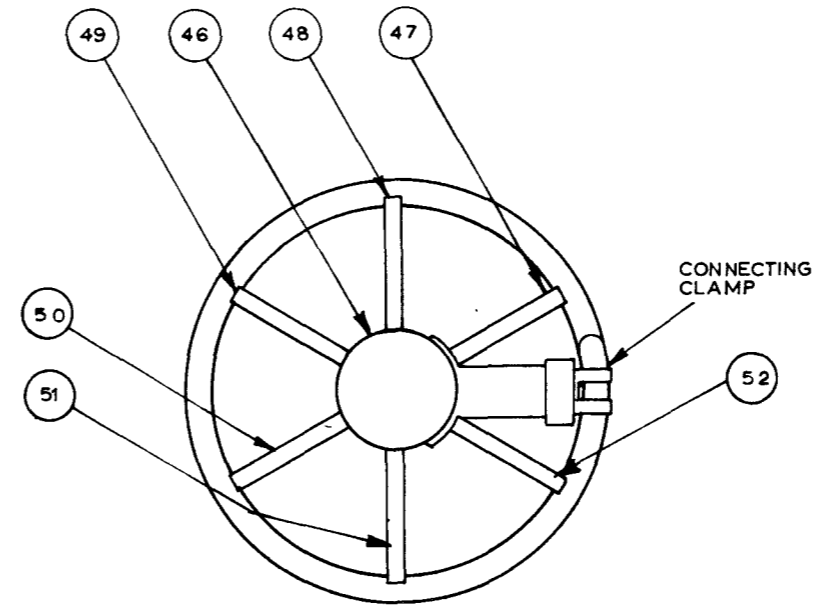
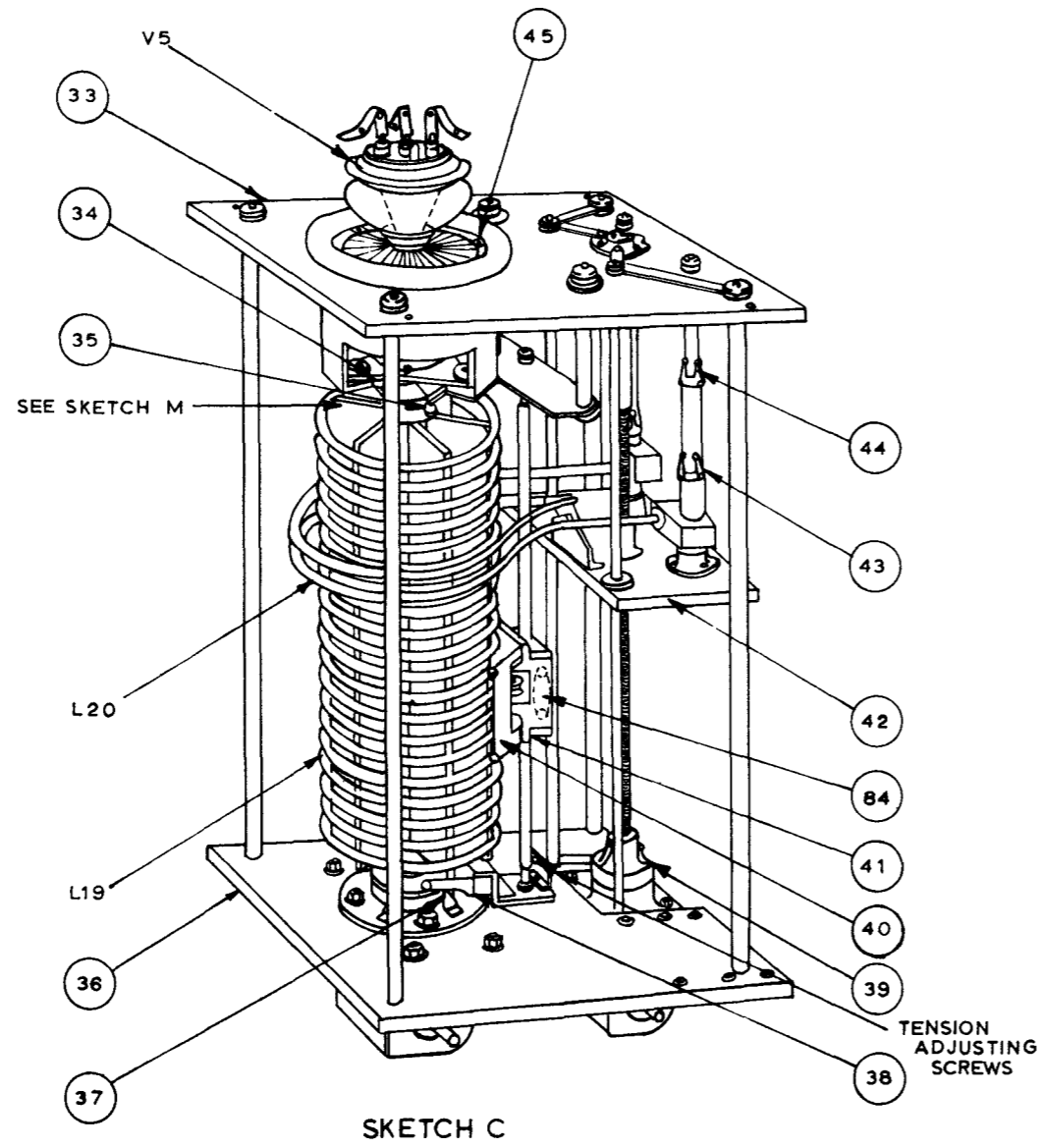
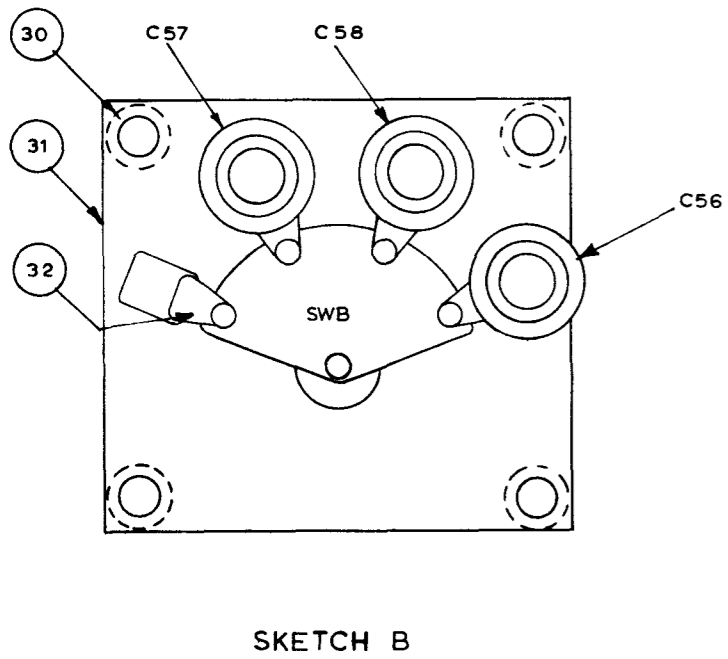
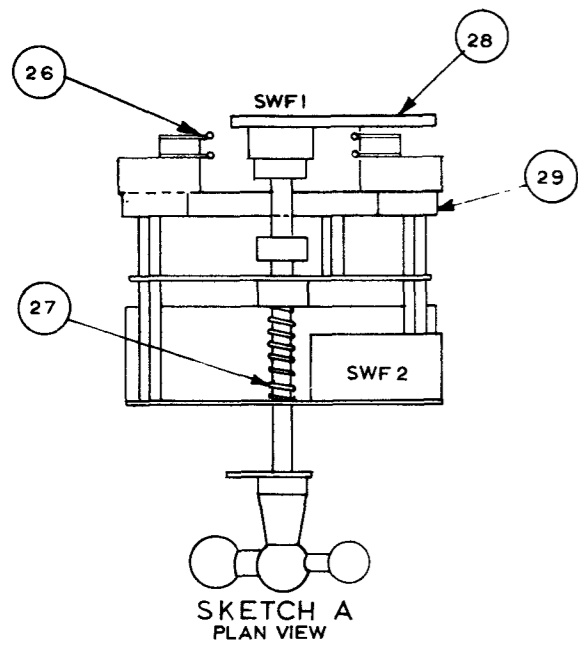
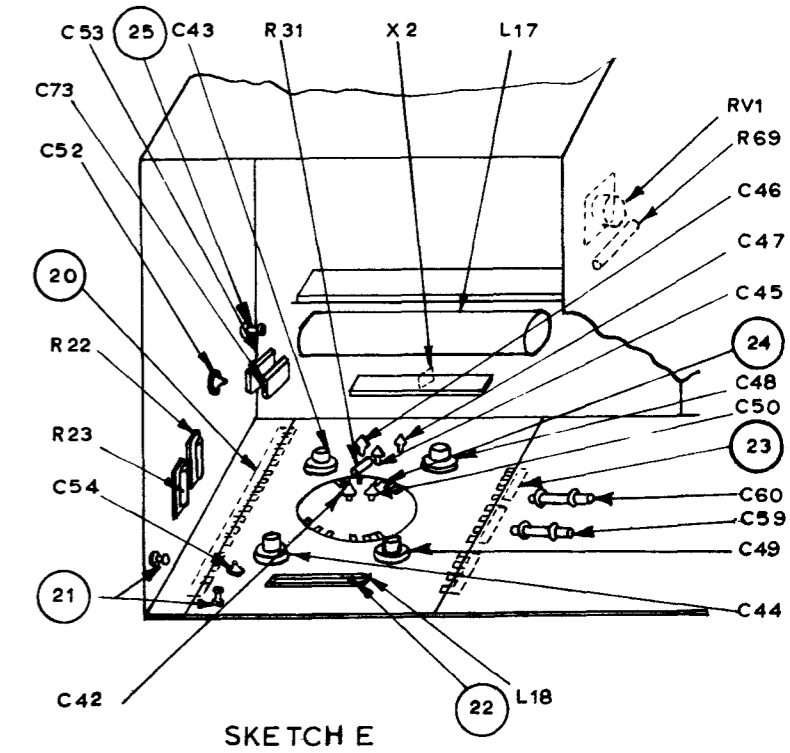
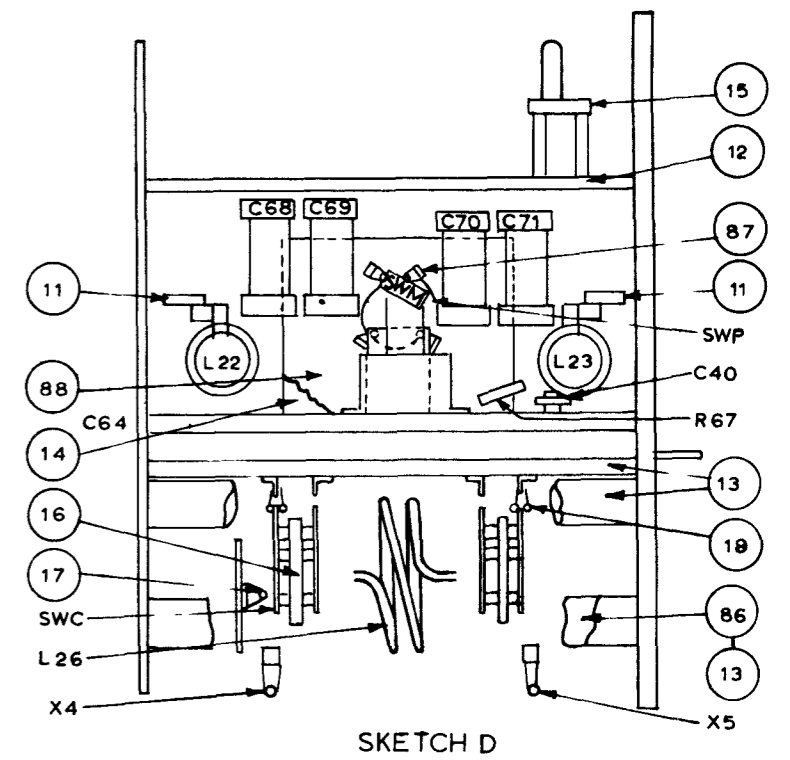
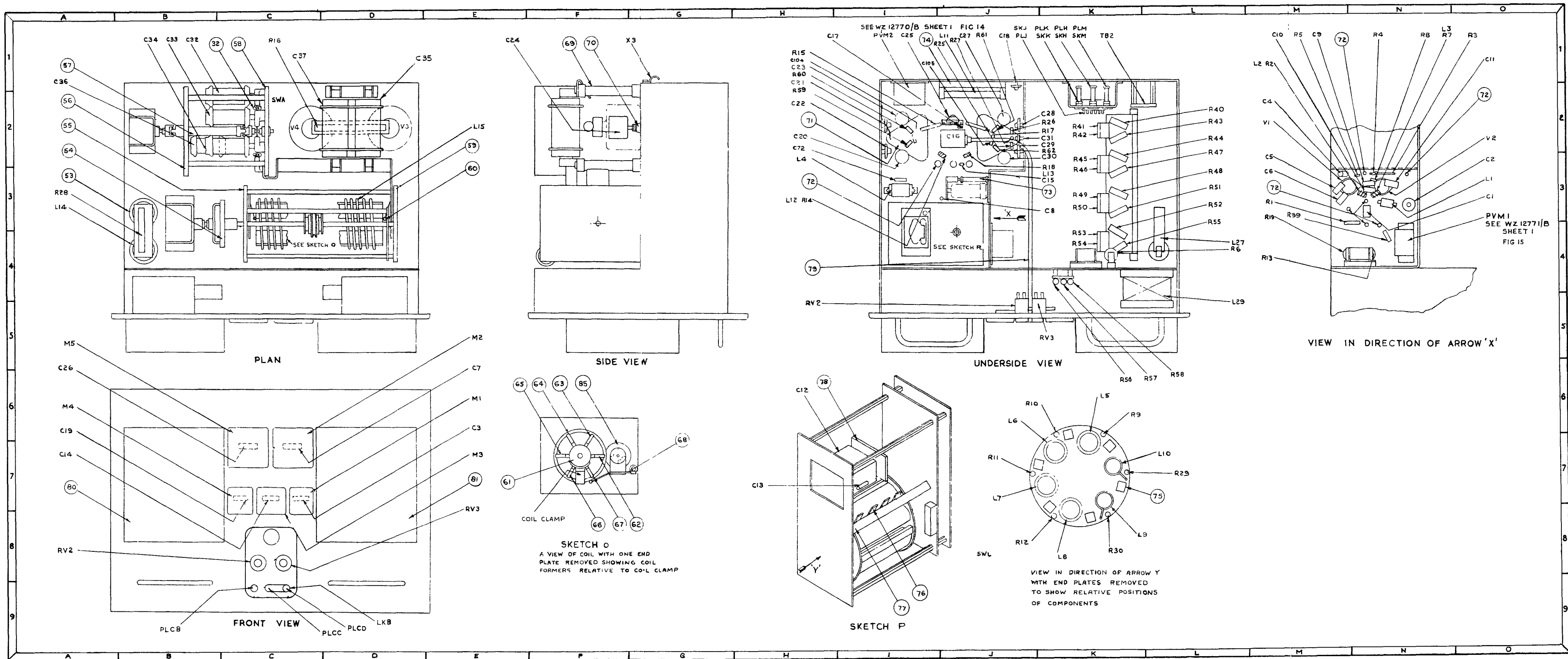
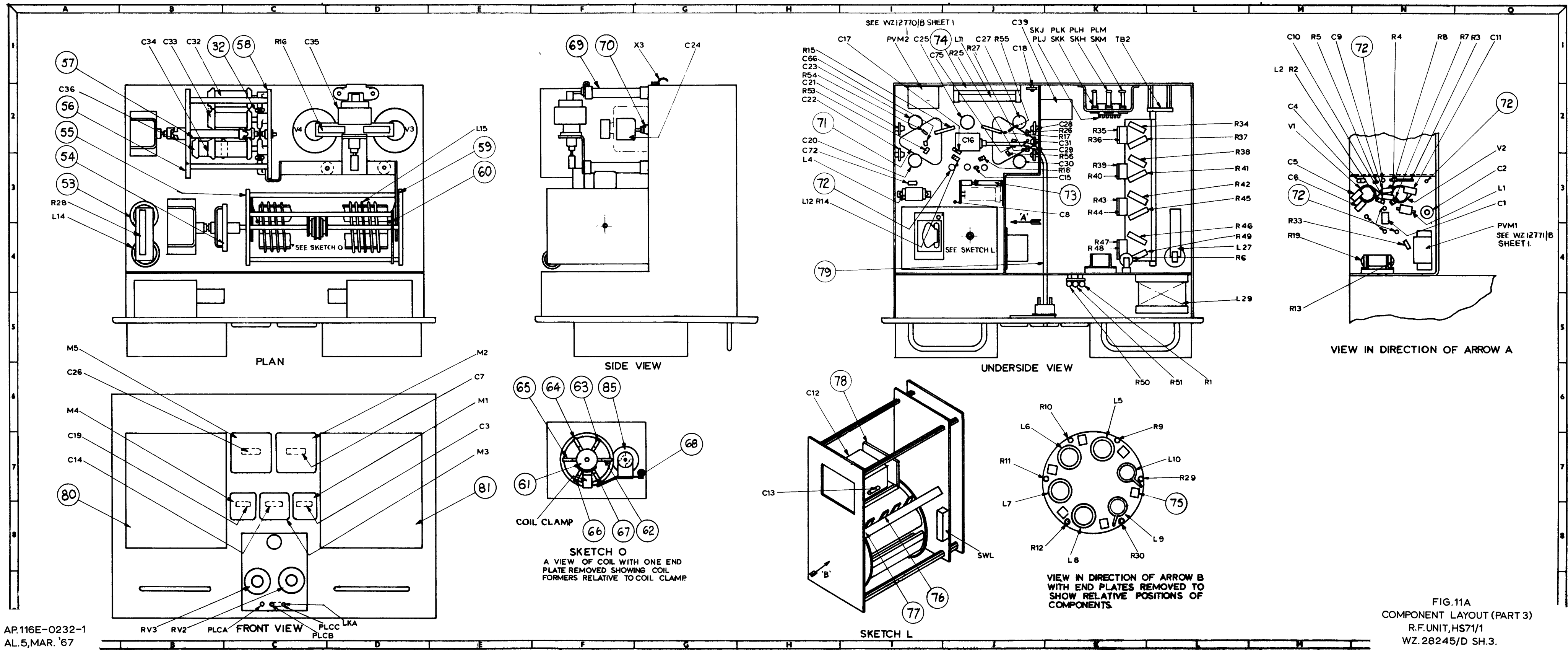

FIG.10A
COMPONENT LAYOUT (PART 2)
R.F.UNIT,HS71/1
WZ.28245/D SH.2.





RADIO FREQUENCY UNIT COMPONENT LAYOUT, PART 3
(WZ. 15040/D Sh. 3 Iss. 7)



AP.116E-0232-1
AL.5, MAR. '67

FIG. 11A
COMPONENT LAYOUT (PART 3)
R.F. UNIT, HS71/1
WZ. 28245/D SH. 3.

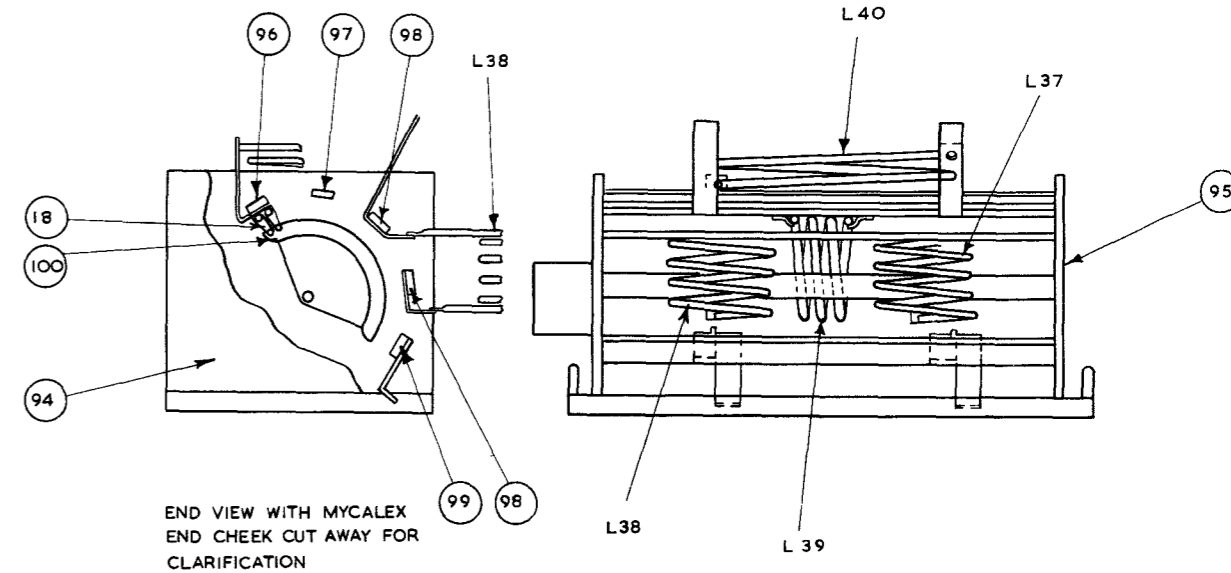
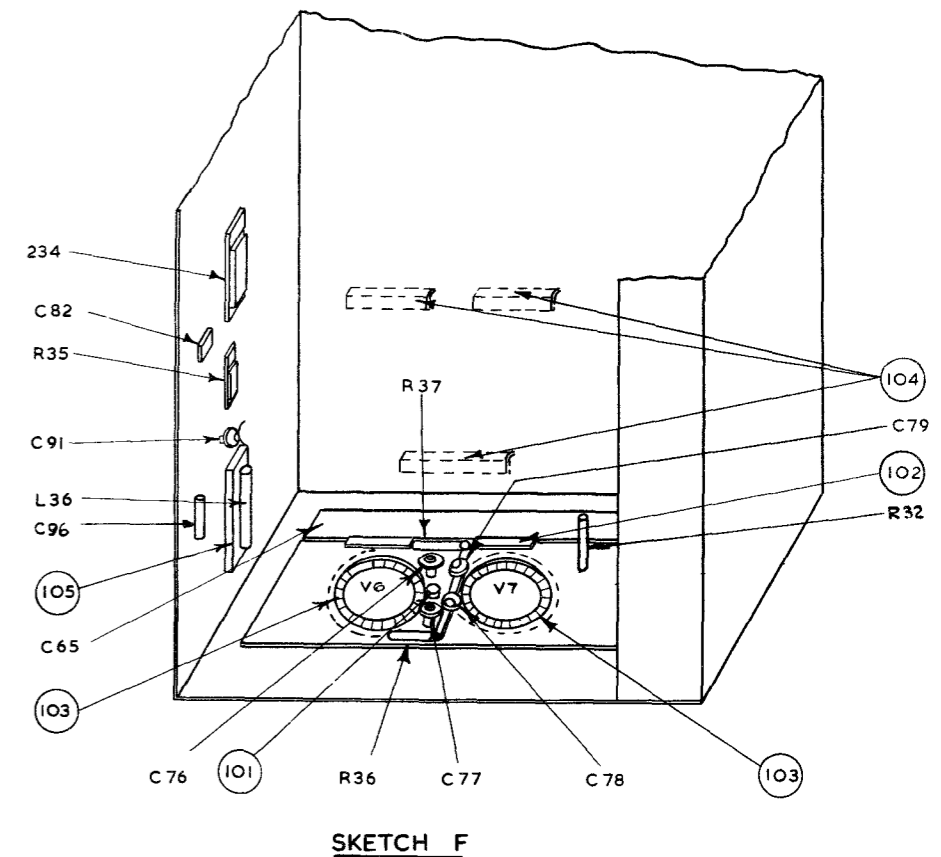
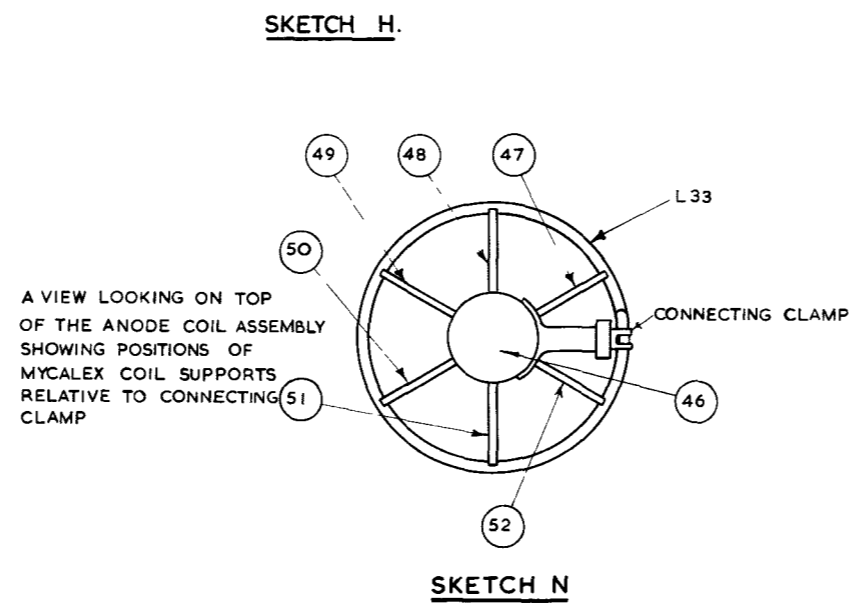
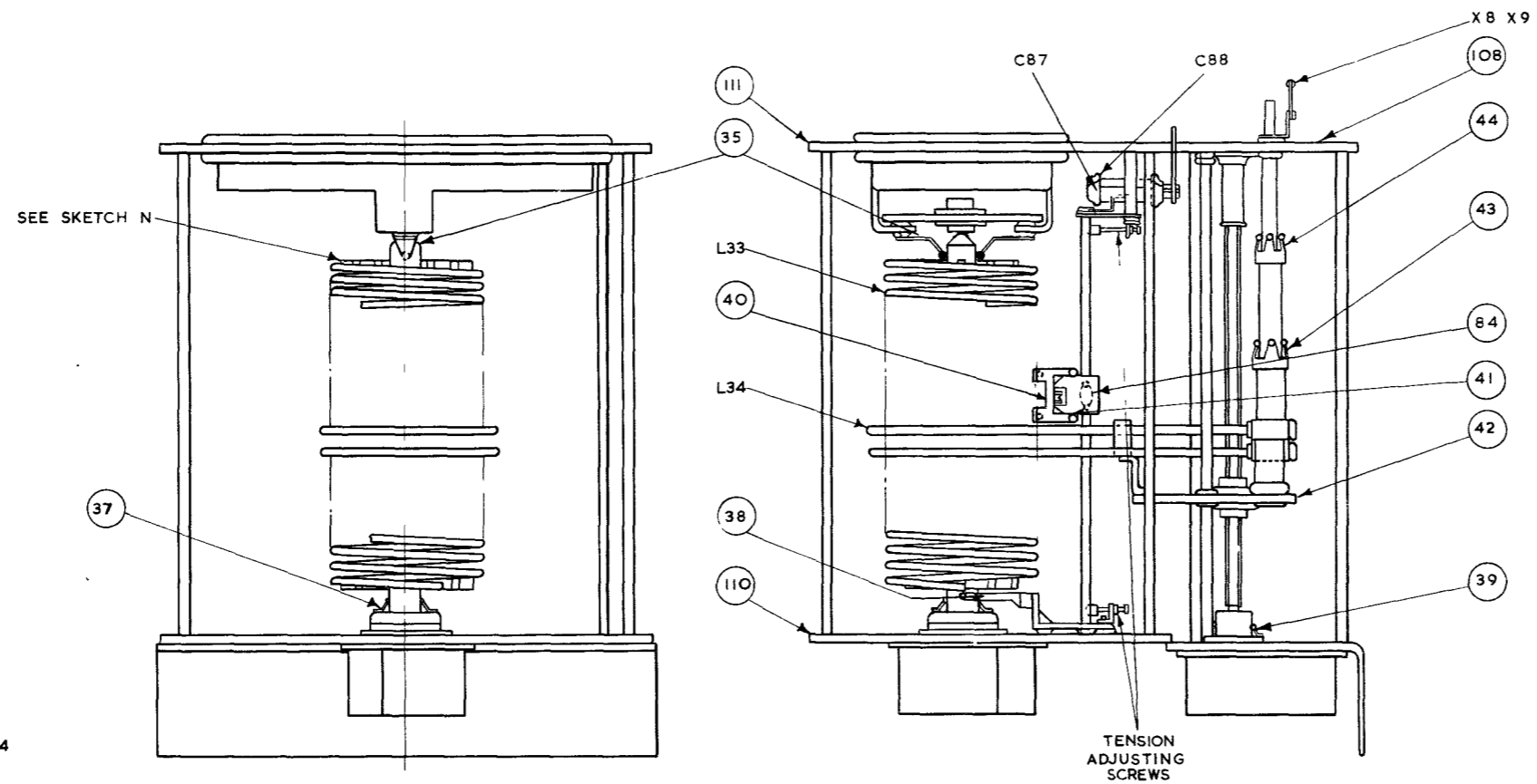
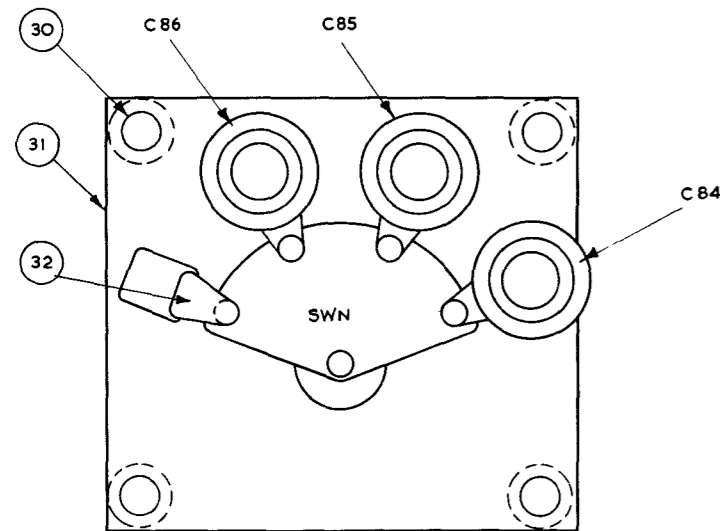
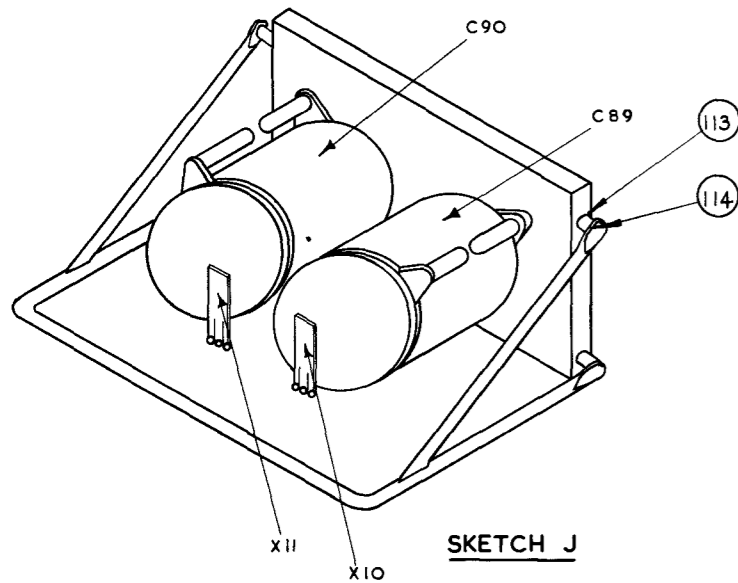

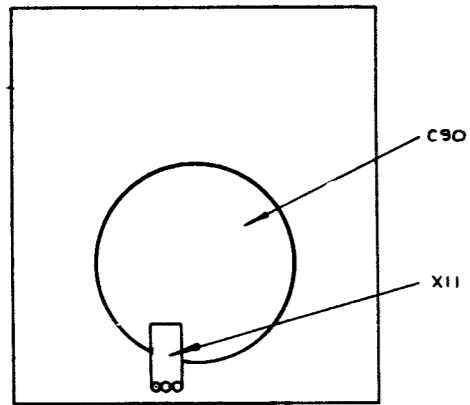

SKETCH J

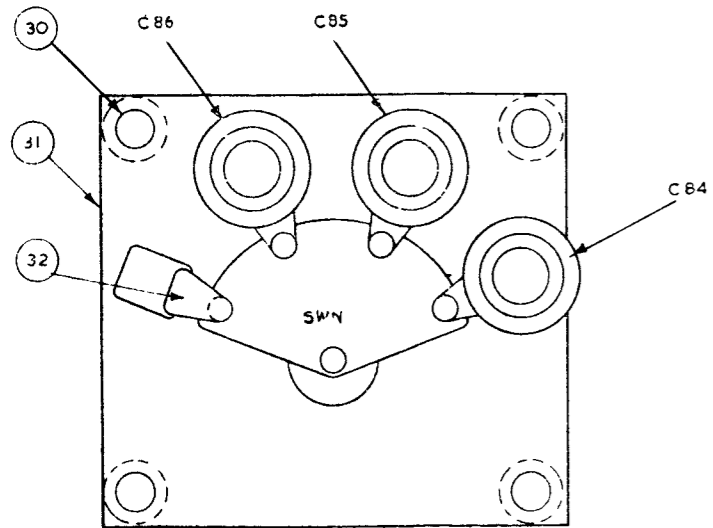

SKETCH G

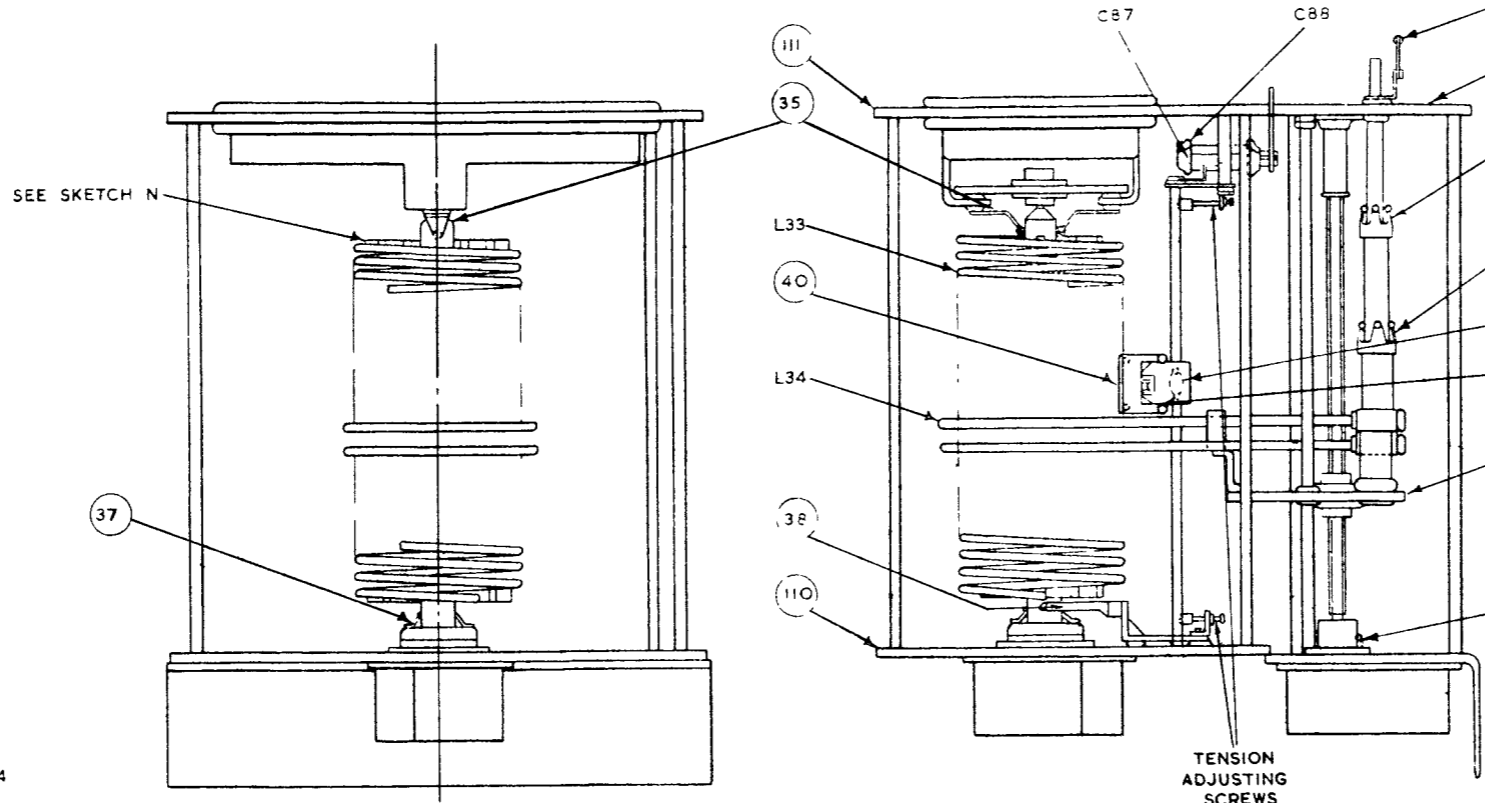

SKETCH H

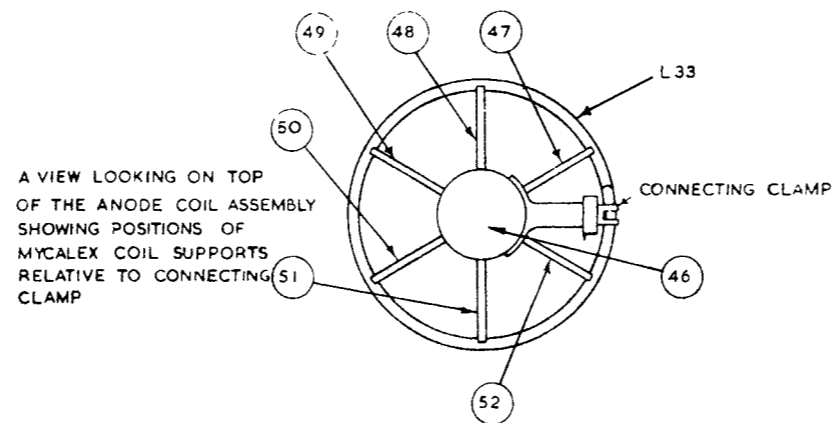

SKETCH N

A VIEW LOOKING ON TOP OF THE ANODE COIL ASSEMBLY SHOWING POSITIONS OF MYCALEX COIL SUPPORTS RELATIVE TO CONNECTING CLAMP

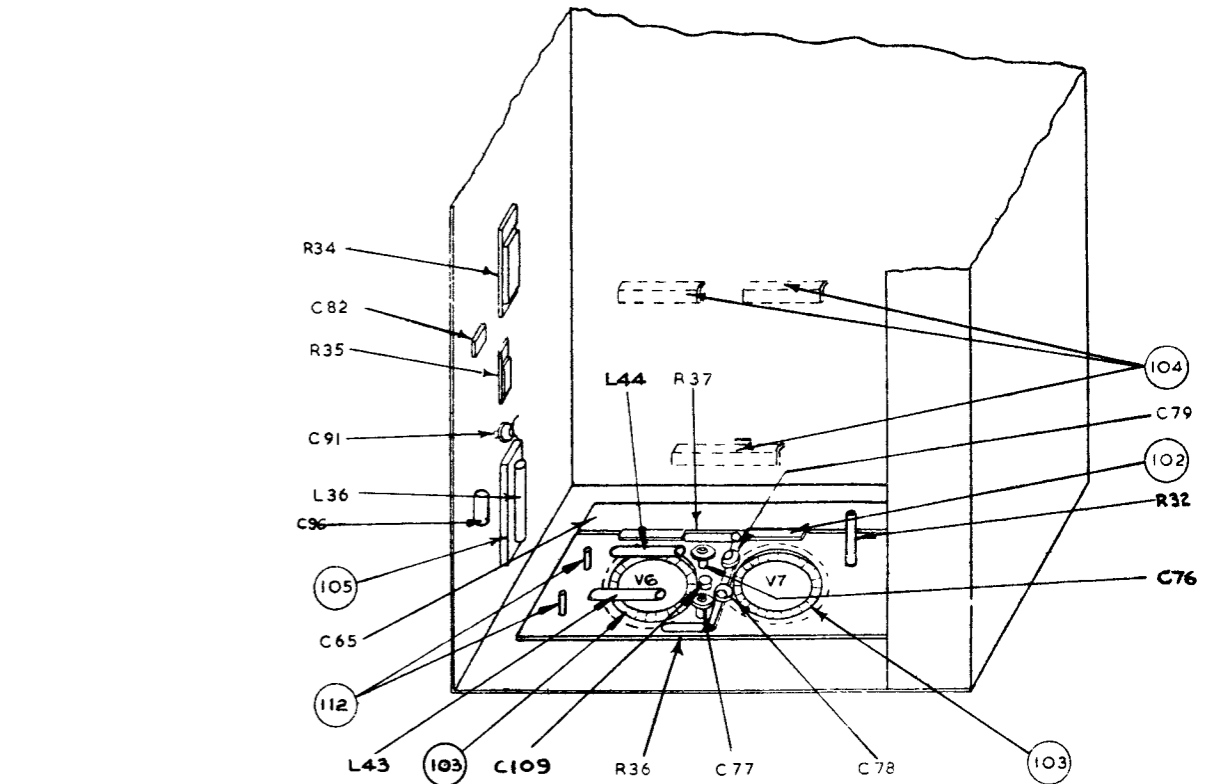

SKETCH F

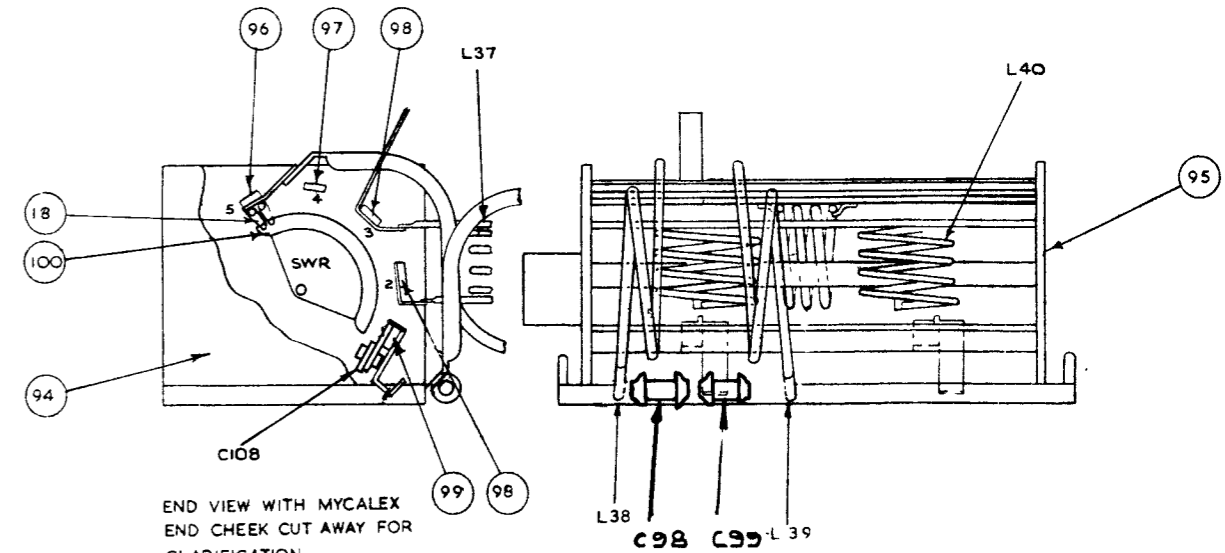

SKETCH K

END VIEW WITH MYCALEX END CHEEK CUT AWAY FOR CLARIFICATION

FIG.12A
COMPONENT LAYOUT (PART 4)
R.F. UNIT, HS. 71/1
WZ. 28245/D SH. 4.

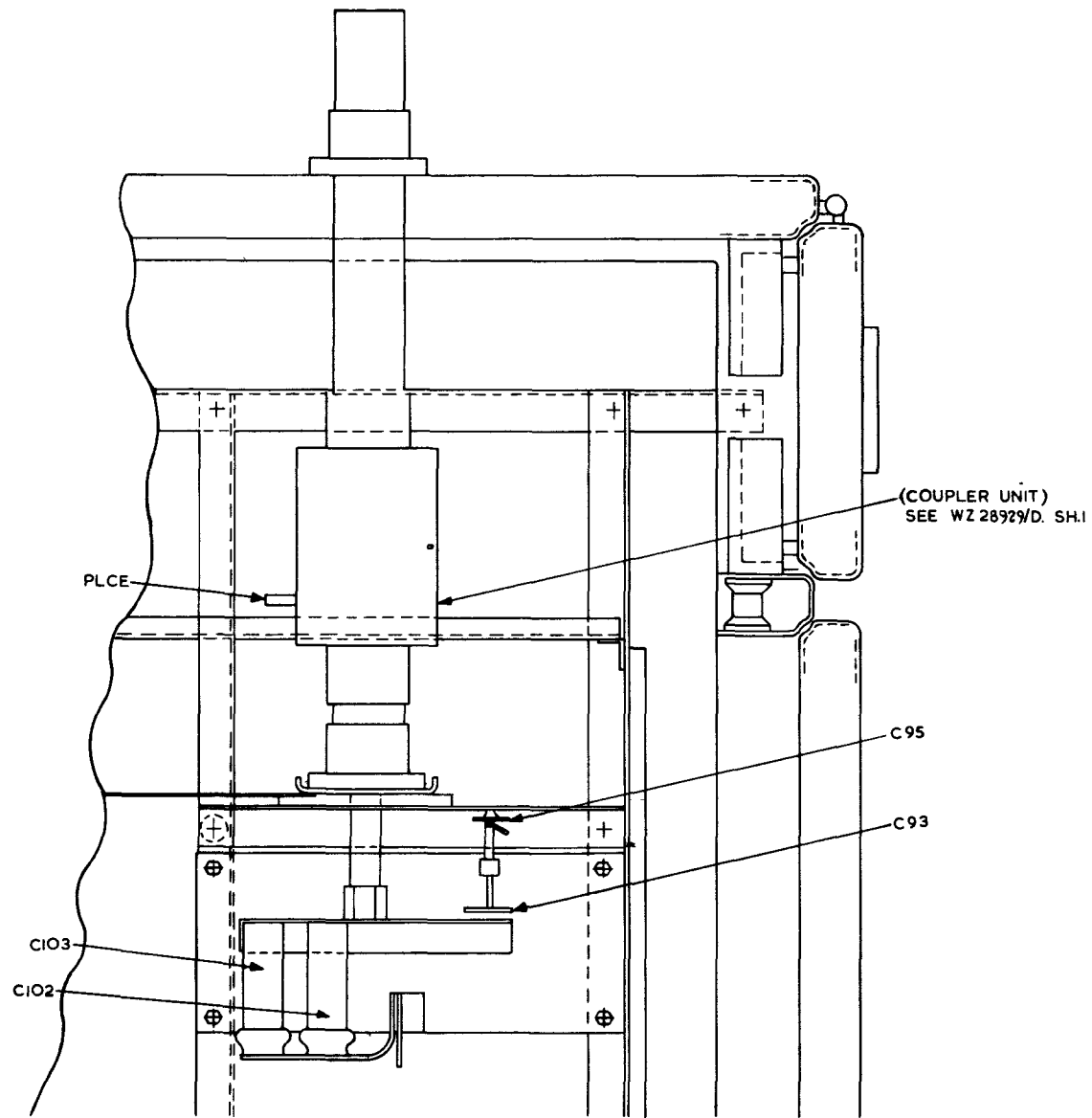

SKETCH P

AP.116E-0232-1
AL.5,MAR.'67

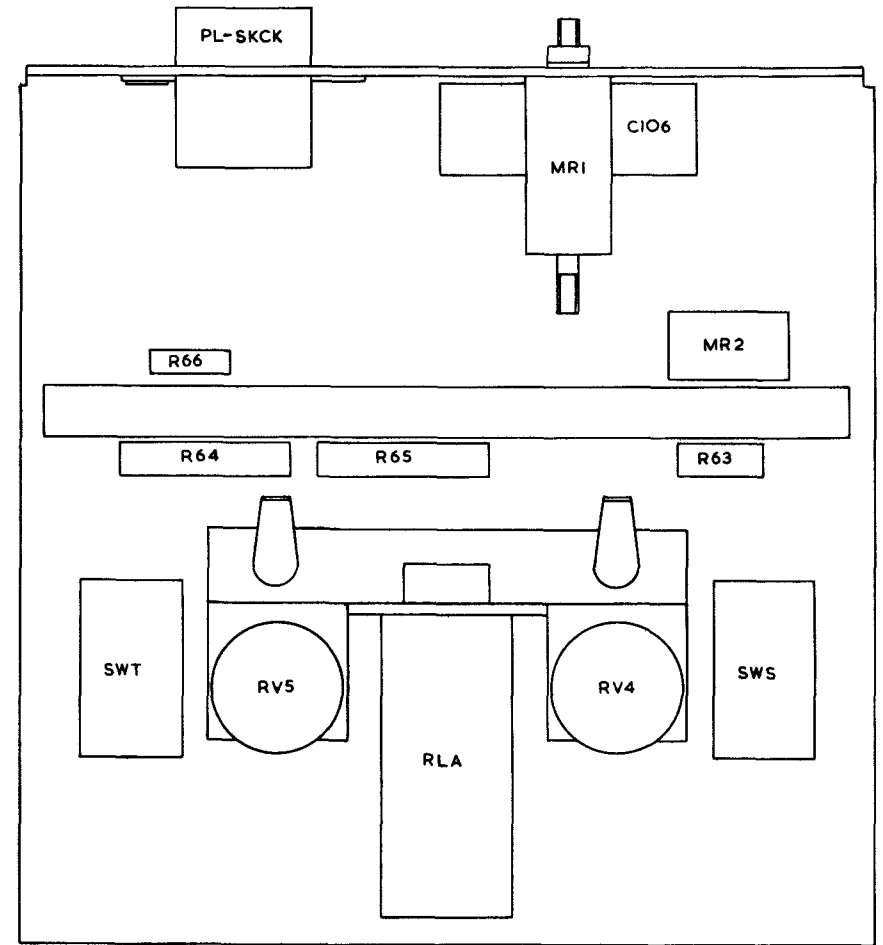

SKETCH Q

VIEWED FROM REAR OF PANEL
WITH COVER REMOVED

FIG.12B
COMPONENT LAYOUT (PART 5)
R.F. UNIT, HS. 71/1
W.Z. 28245/D SH. 5.

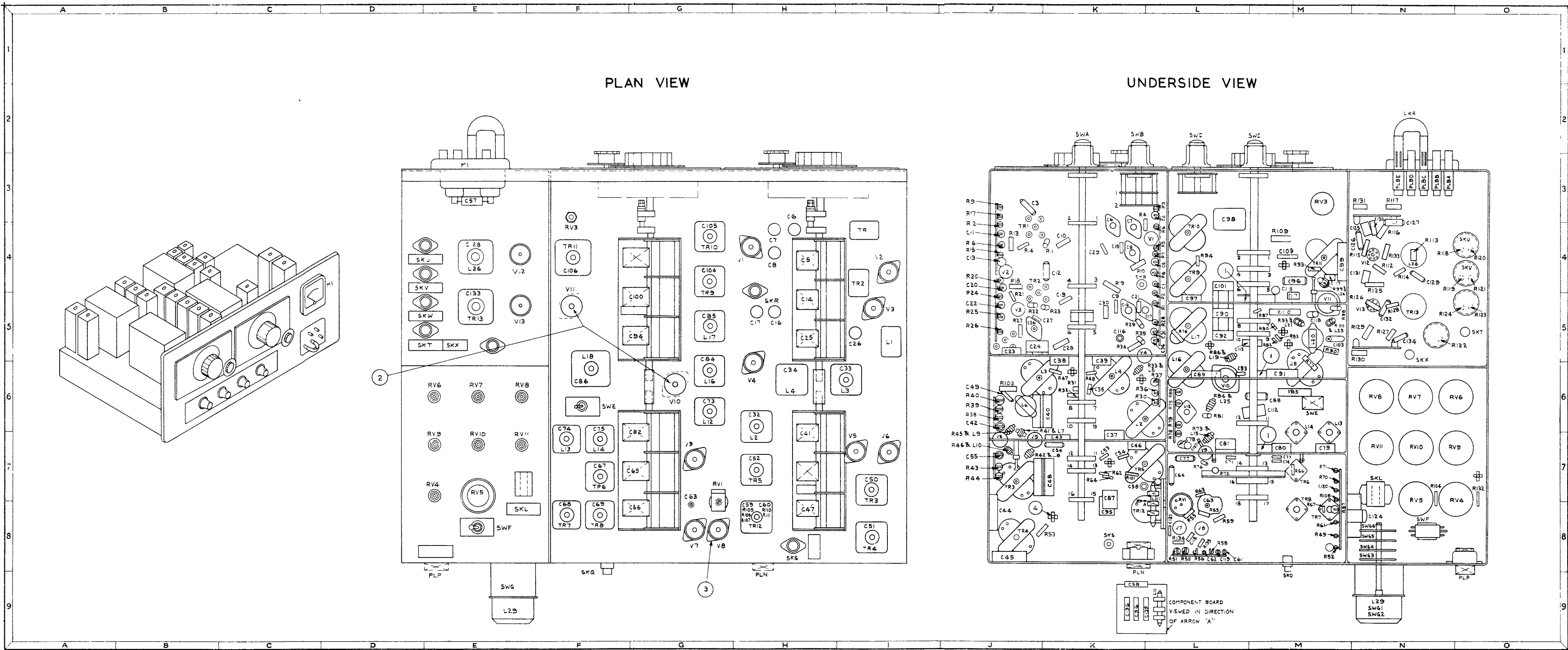

MIXER UNIT COMPONENT LAYOUT
(WZ. 15042/D Sh. 1 Iss 6)

FIG.13A MIXER UNIT COMPONENT LAYOUT

Changes arising from modification 1312

(Monitoring of Transmitter, Radio, Type T.10197B when radiating on frequencies between 2.5 and 20 Mc/s).

Under Modification 1312 the capacitors C59 and C60 in TR13 and L26 are removed.

(To face
Fig. 13A)

PLAN VIEW

UNDERSIDE VIEW

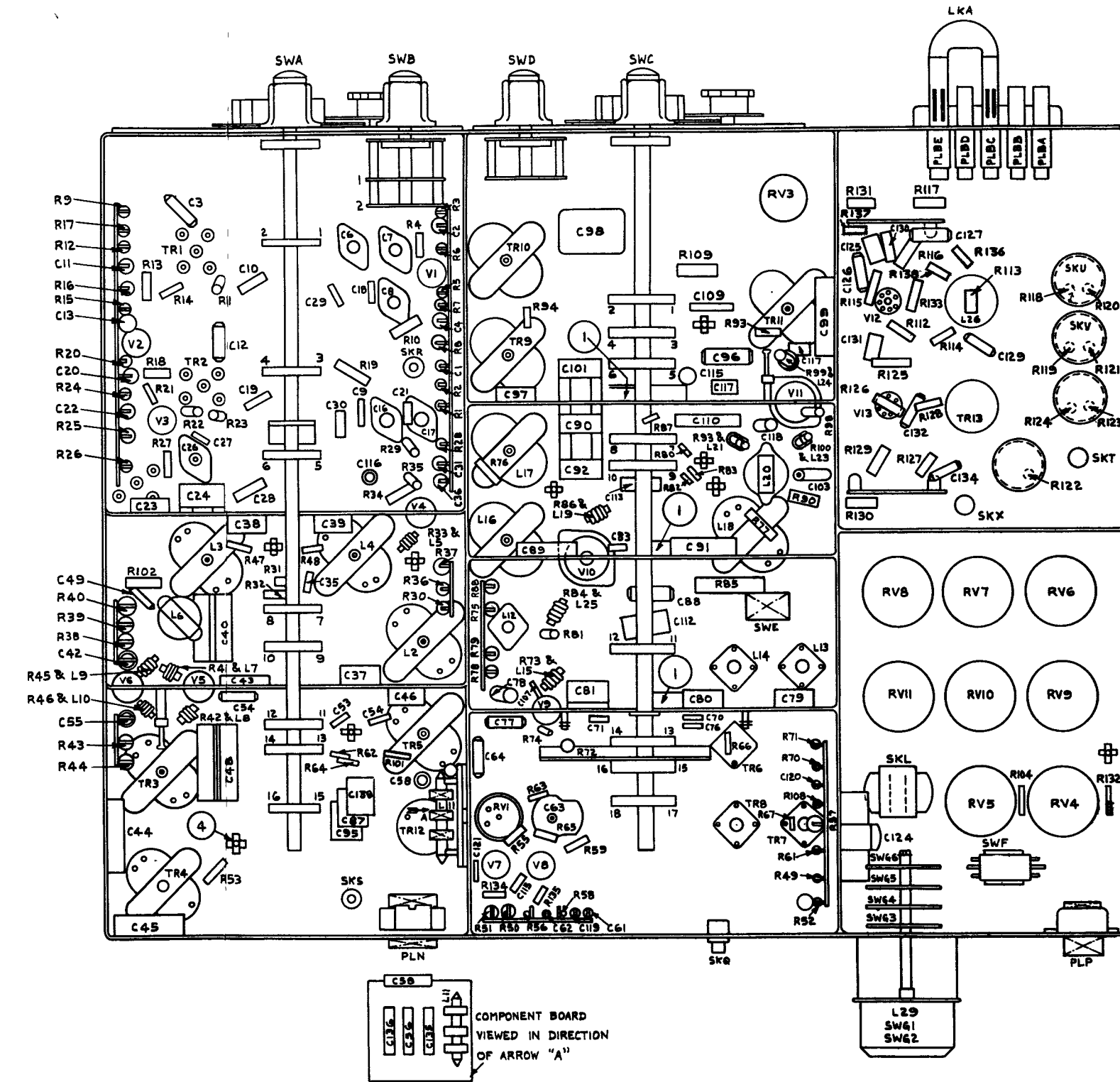
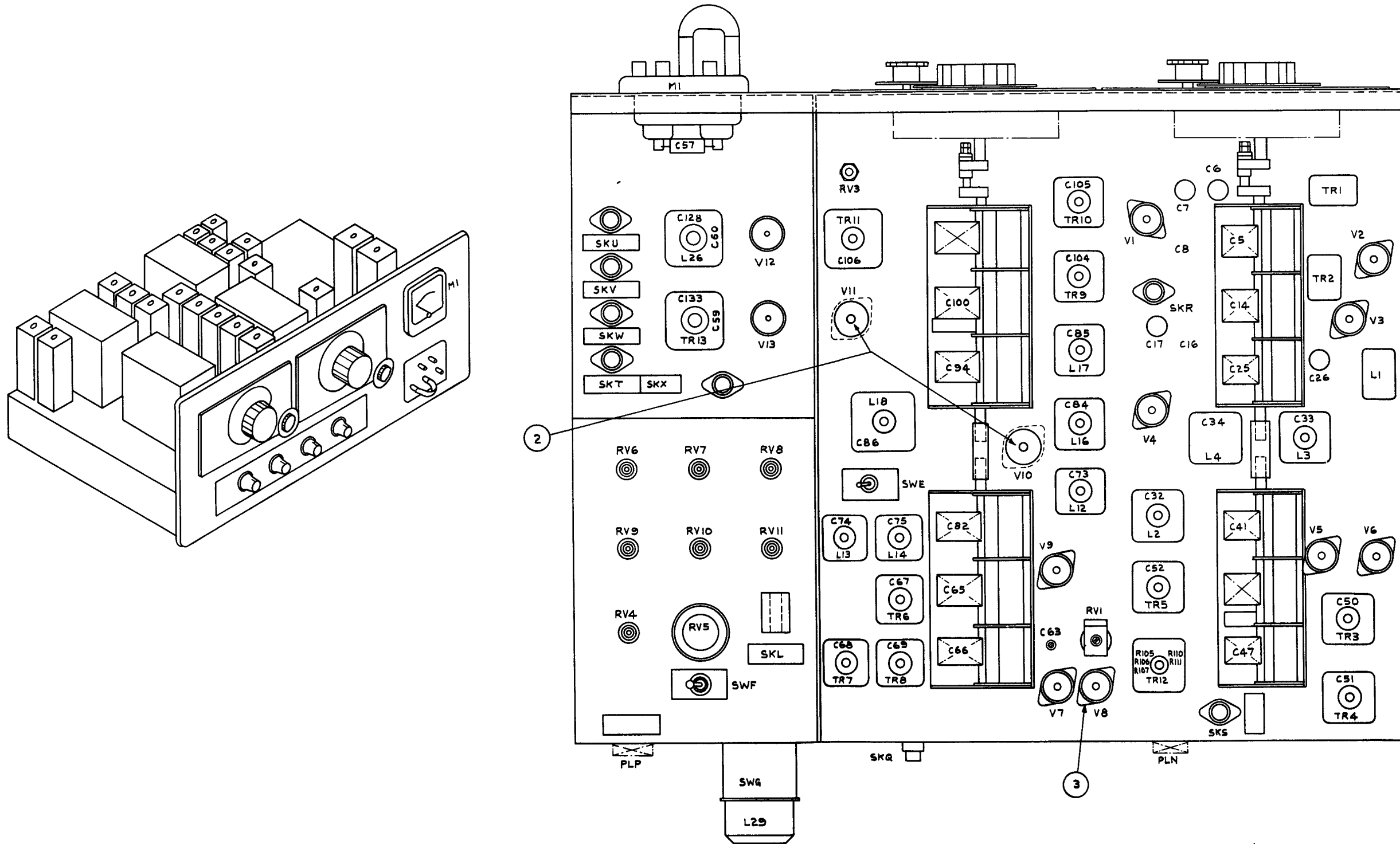

MIXER UNIT
COMPONENT LAYOUT (HS71A)
WZ.24357/D Sh.1 Iss.1

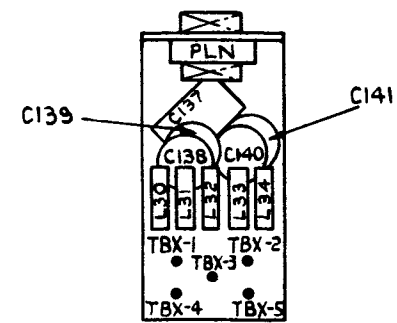
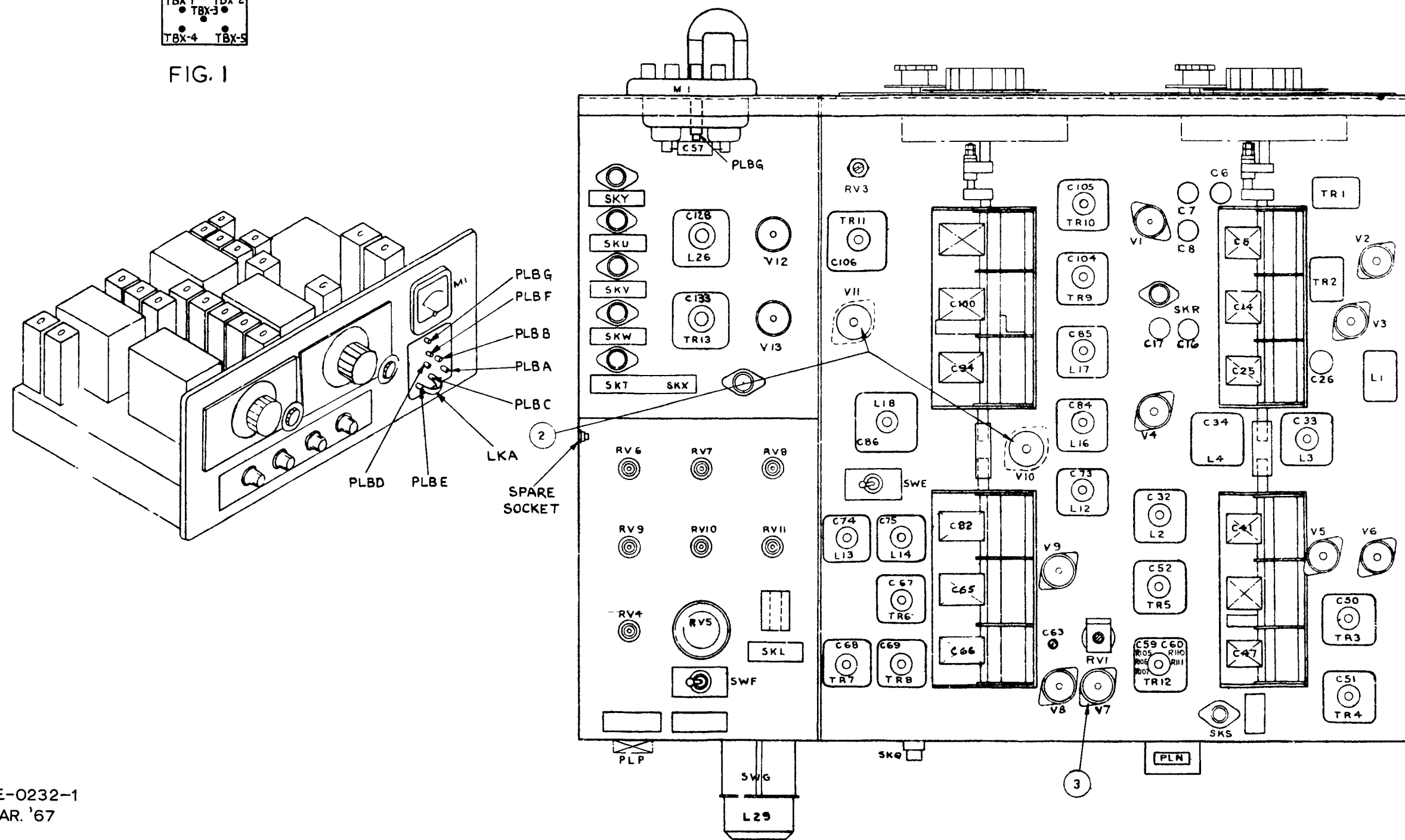
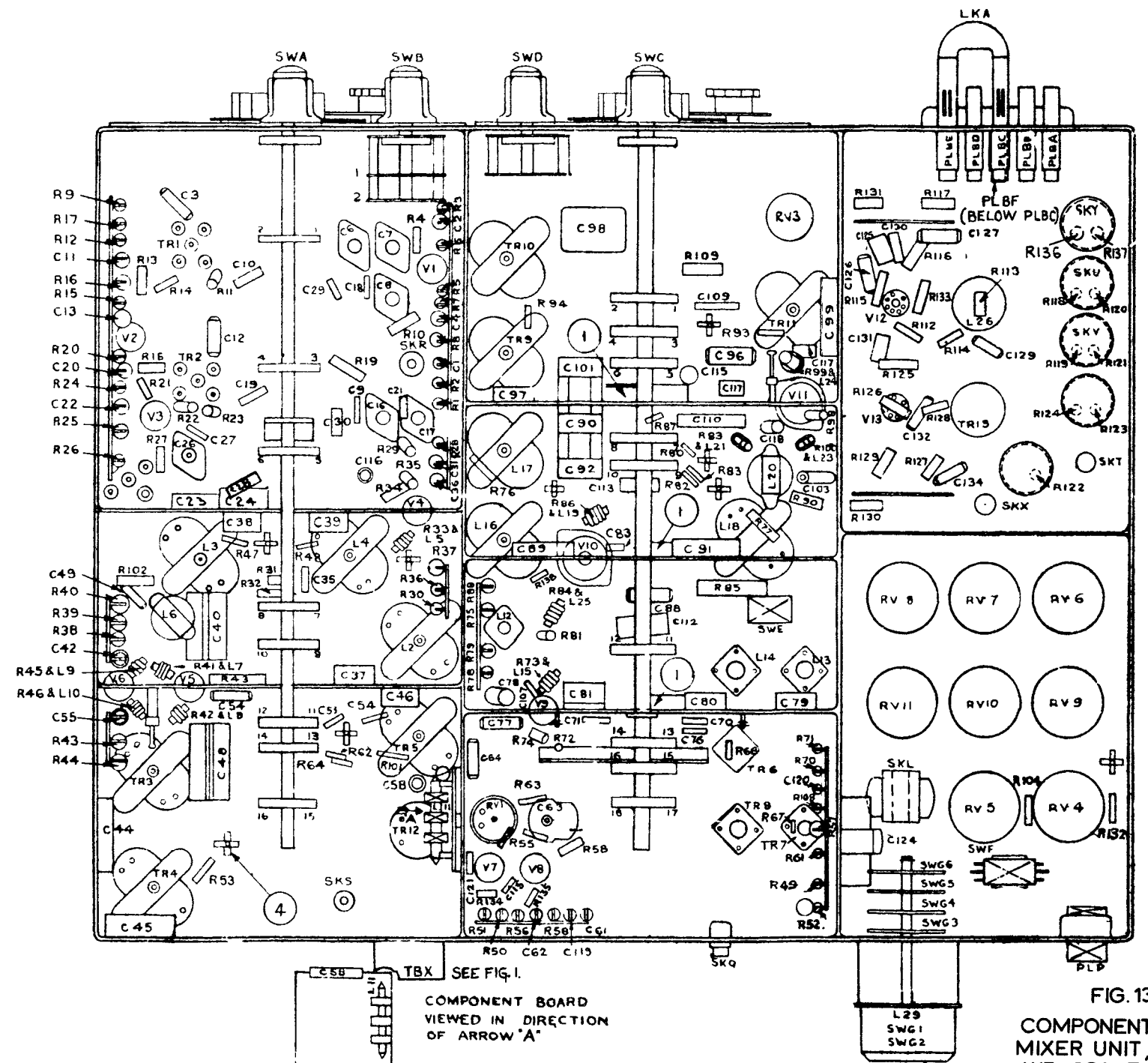

FIG. 1

PLAN VIEW



UNDERSIDE VIEW



COMPONENT BOARD
VIEWED IN DIRECTION
OF ARROW 'A'

FIG. 13B
COMPONENT LAYOUT
MIXER UNIT, HS. 71/1
WZ. 28247/D SH. 1.

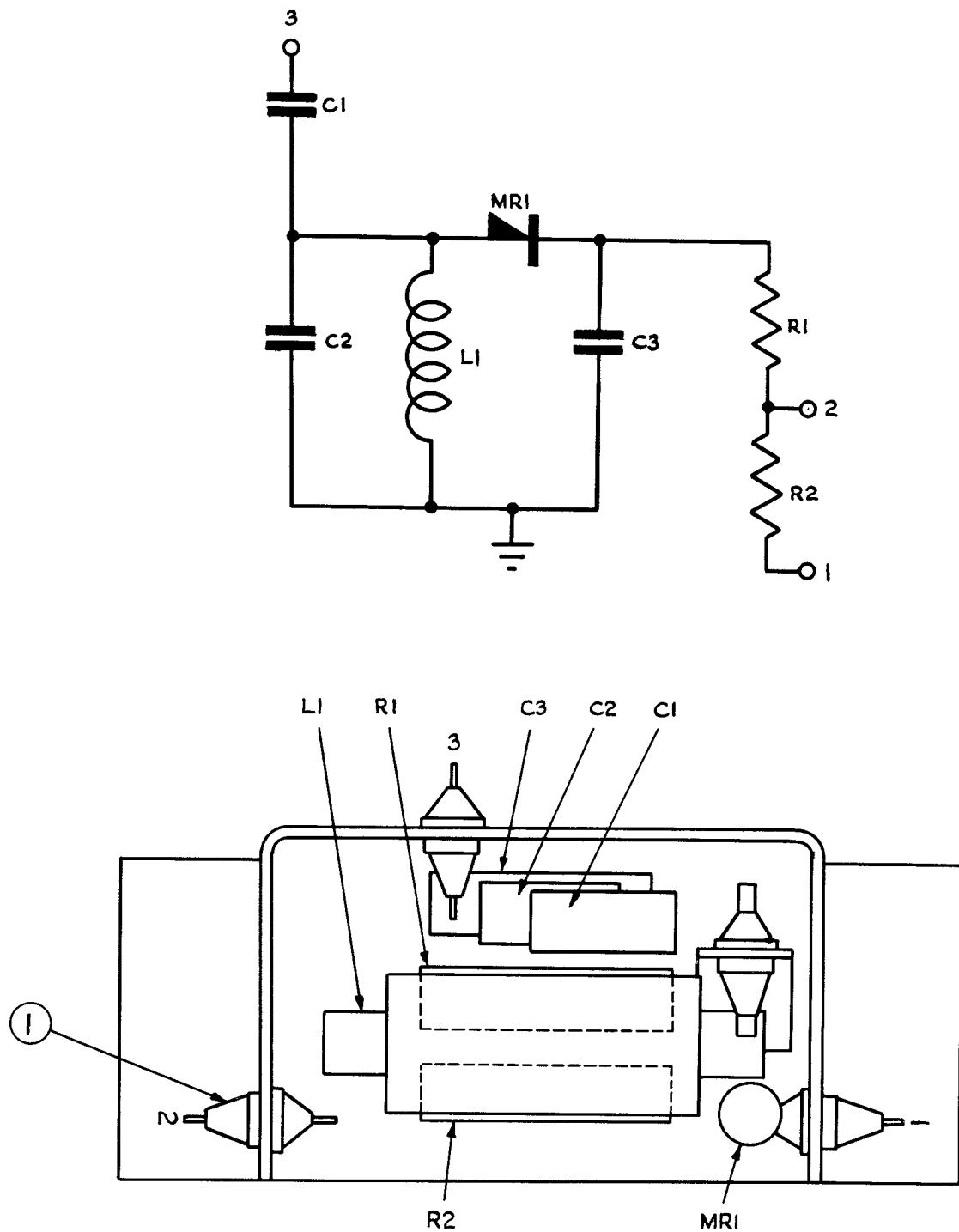

RANGE 0 - 250 VOLTS WHEN CONNECTED TO TERMINAL 1 & EARTH.

PEAK VOLTMETER UNIT CIRCUIT DIAGRAM AND COMPONENT LAYOUT
(WZ.12770/B Sh.1 Iss.1)

FIG. 14

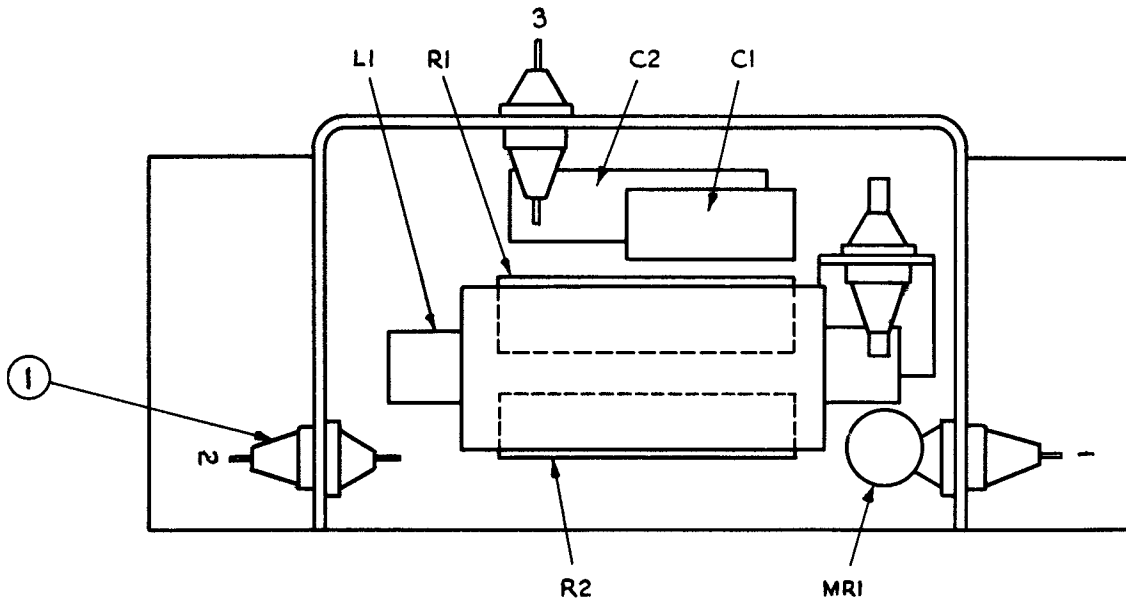
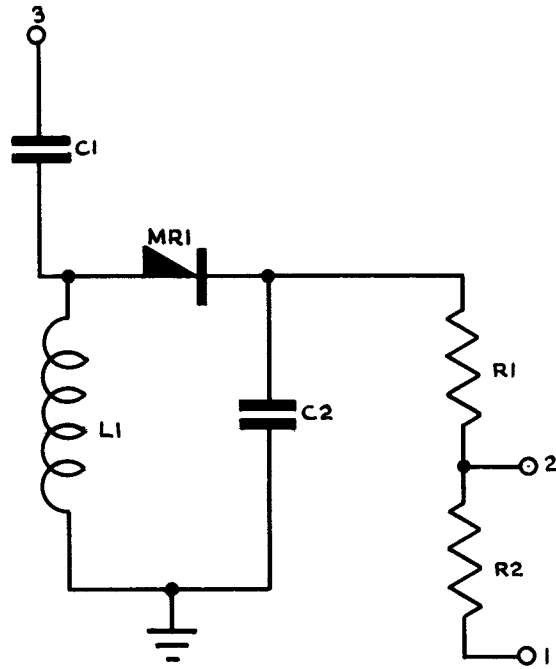

RANGE { 0-15 VOLTS WHEN CONNECTED TO TERMINAL 1 & EARTH
 0-5 VOLTS WHEN CONNECTED TO TERMINAL 2 & EARTH

PEAK VOLTMETER UNIT CIRCUIT DIAGRAM AND COMPONENT LAYOUT
 (WZ.12771/B Sh.1 Iss.1)

FIG.

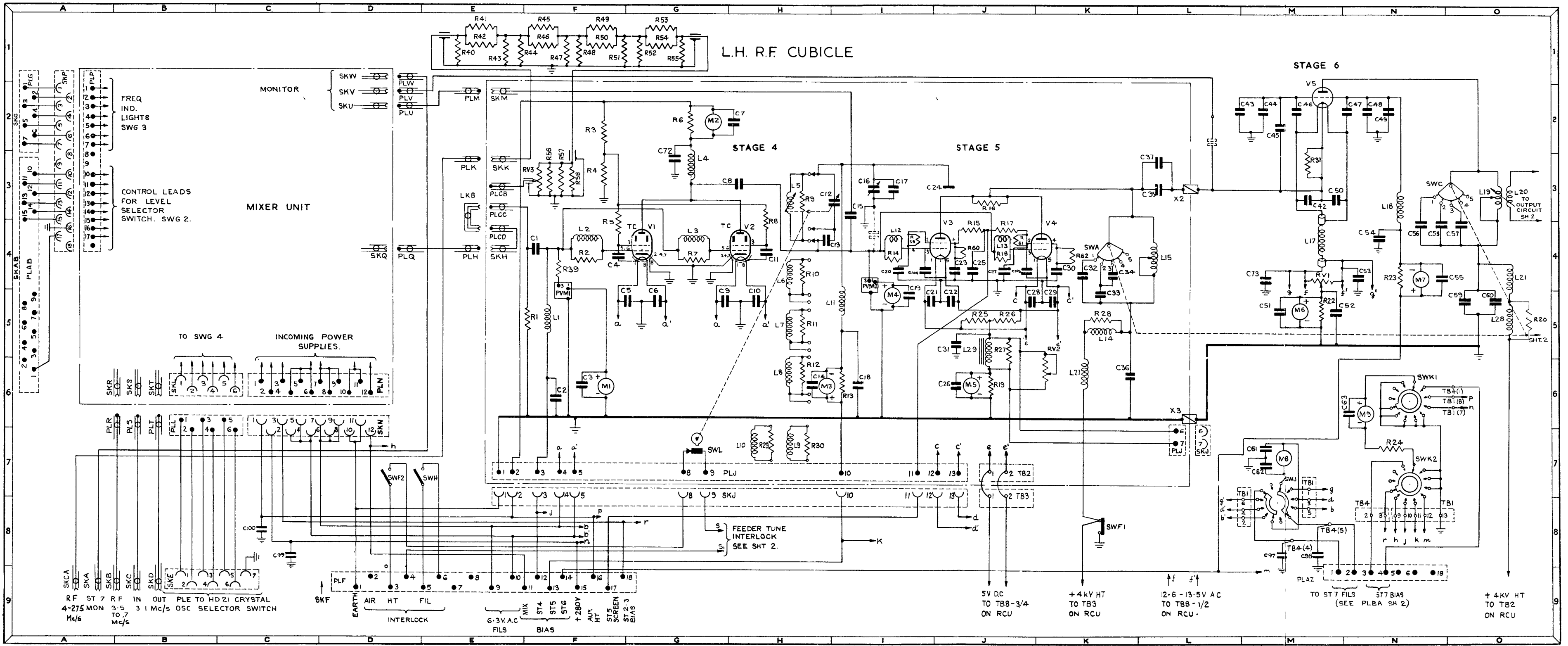

RADIO FREQUENCY UNIT CIRCUIT DIAGRAM, PART 1
(WZ. 15039/D Sh.1 Iss.8)

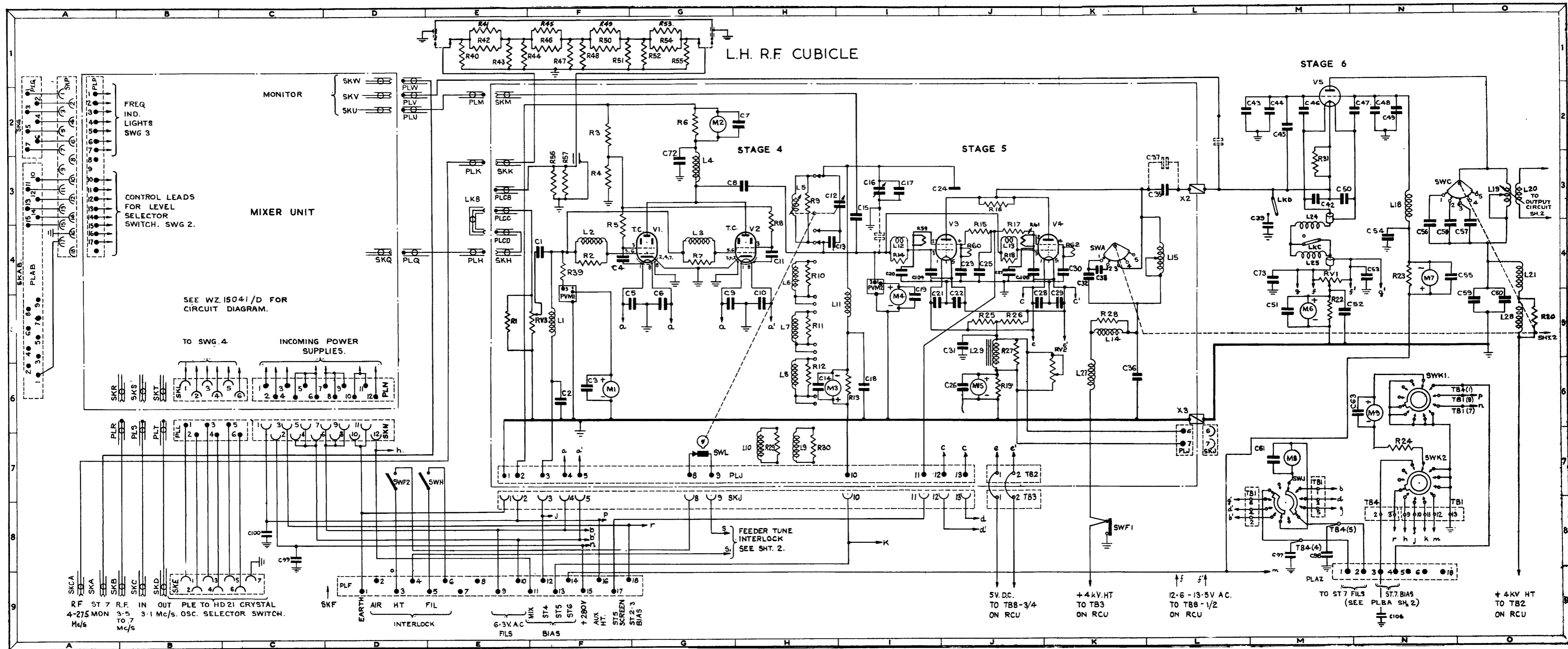

RADIO FREQUENCY UNIT
 CIRCUIT DIAGRAM, PART 1 (HS71A)
 WZ.18274/D Sh.1 Iss.7

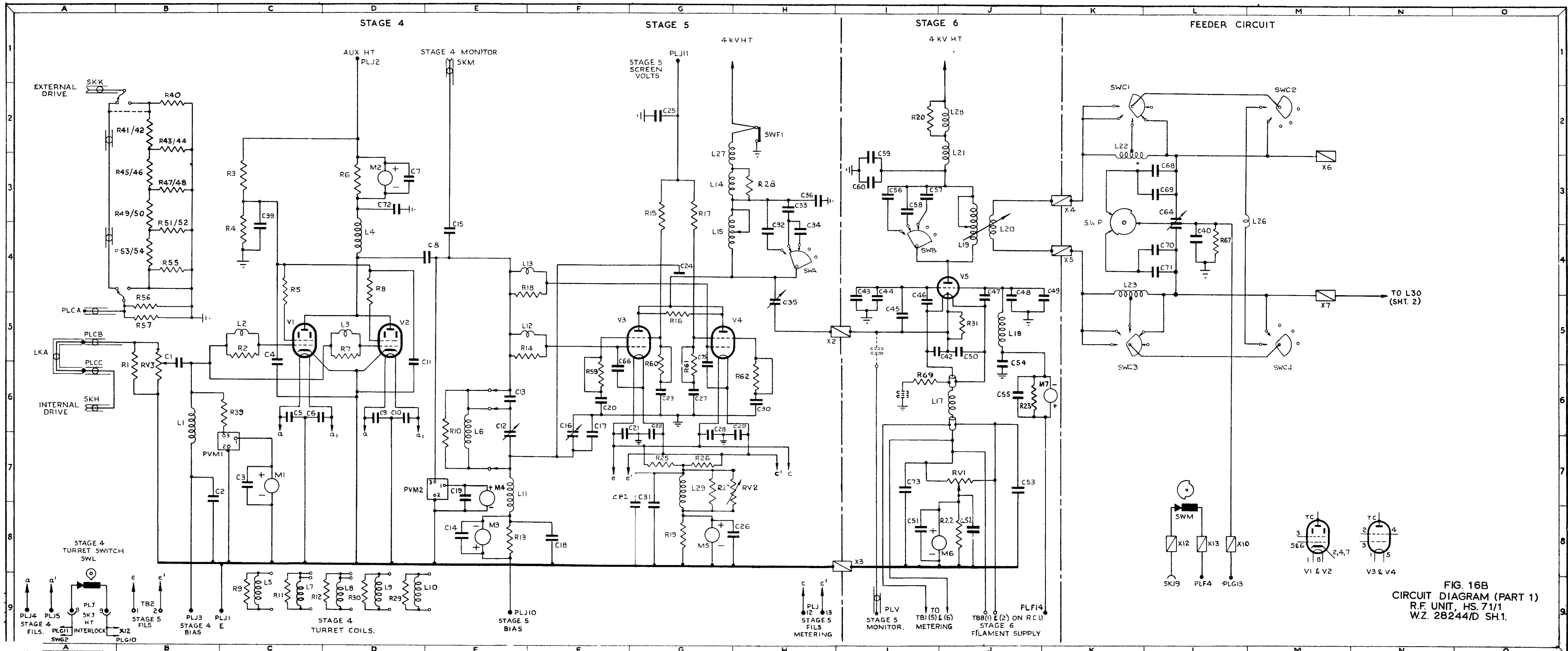
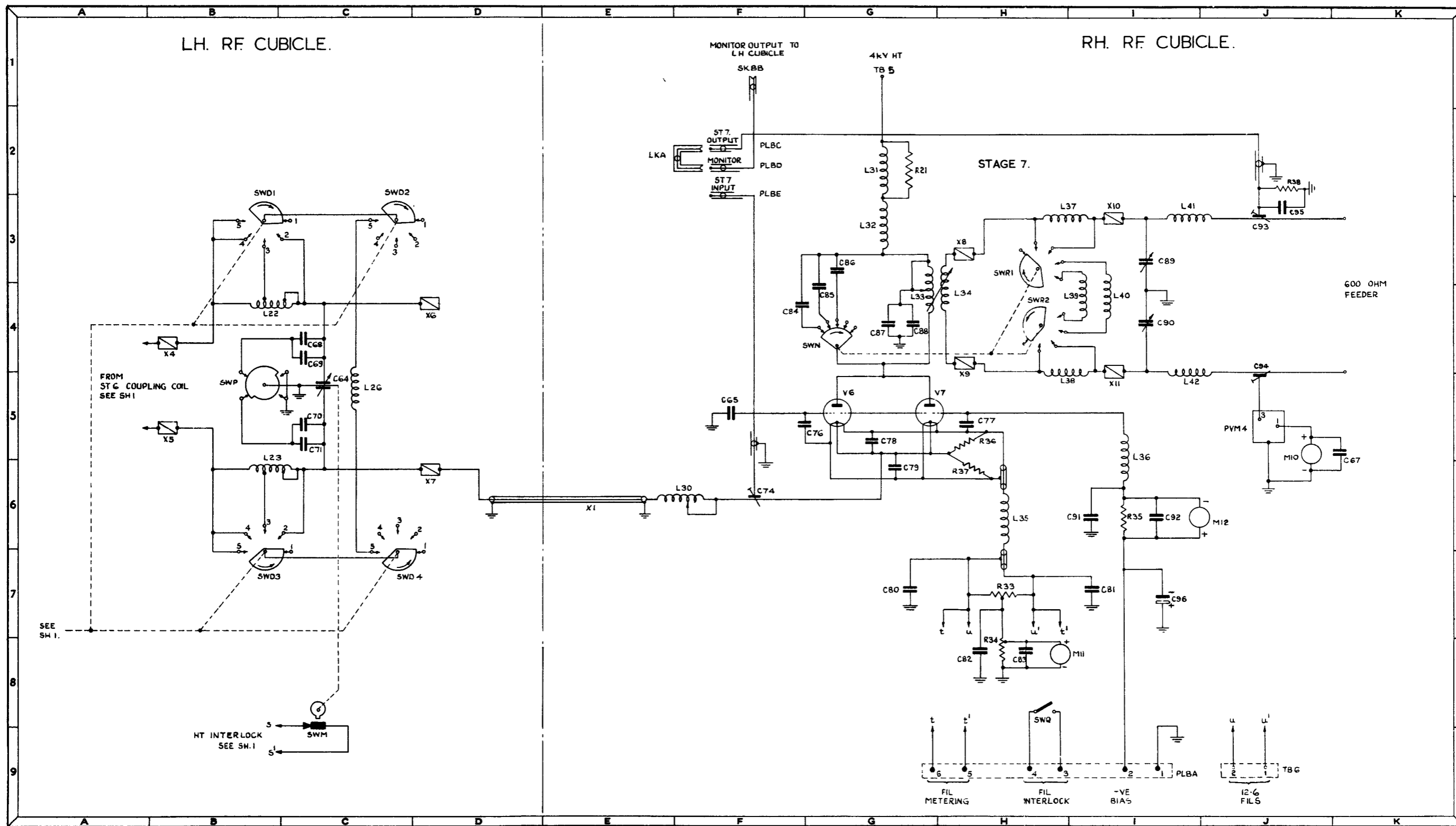

FIG. 16B
CIRCUIT DIAGRAM (PART 1)
R.F. UNIT, HS. 71/1
W.Z. 28244/D SH.1.



RADIO FREQUENCY UNIT CIRCUIT DIAGRAM, PART 2
(WZ.15039/D Sh.2 Iss.5)

LH. RF CUBICLE.

RH. RF CUBICLE.

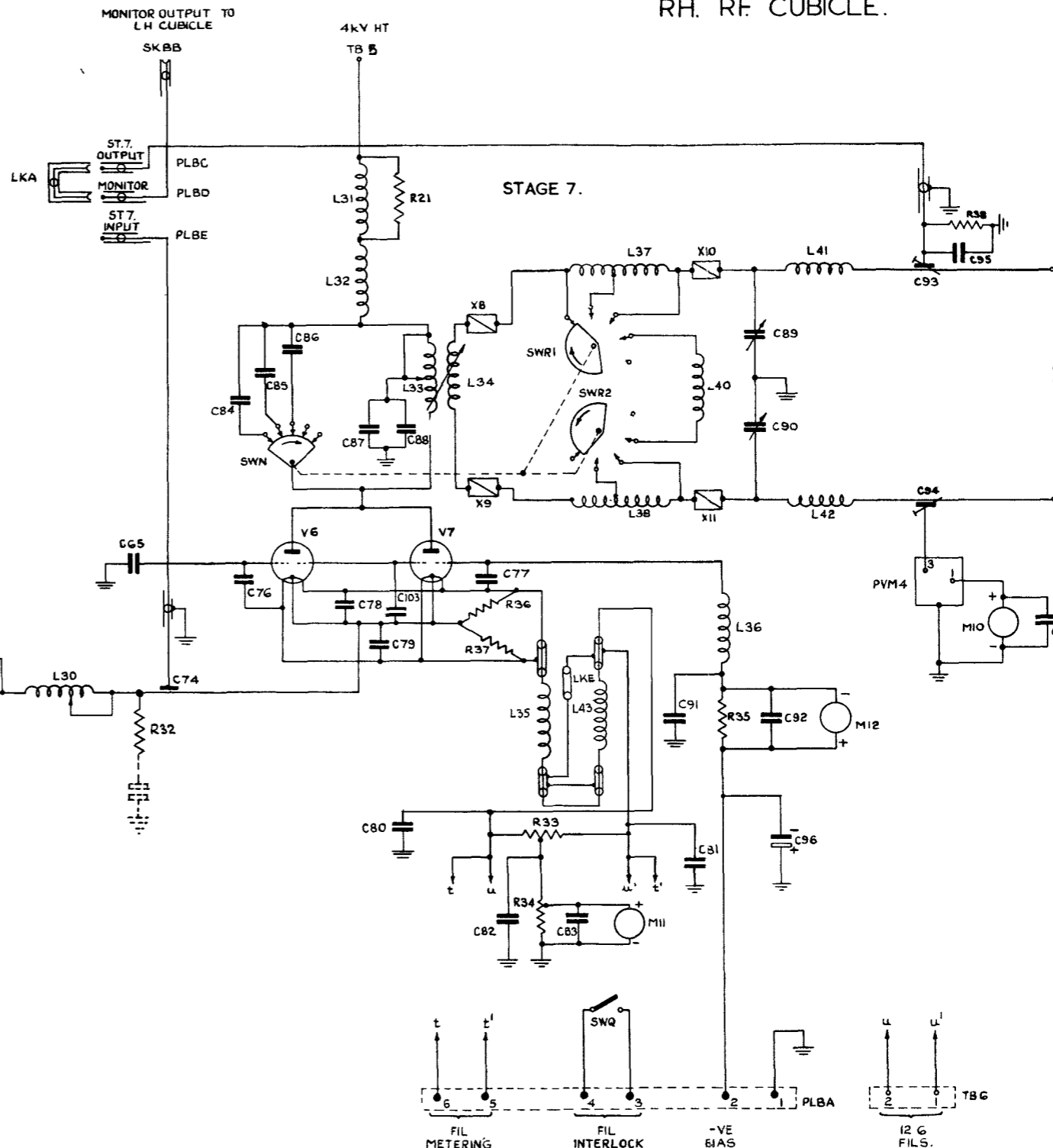
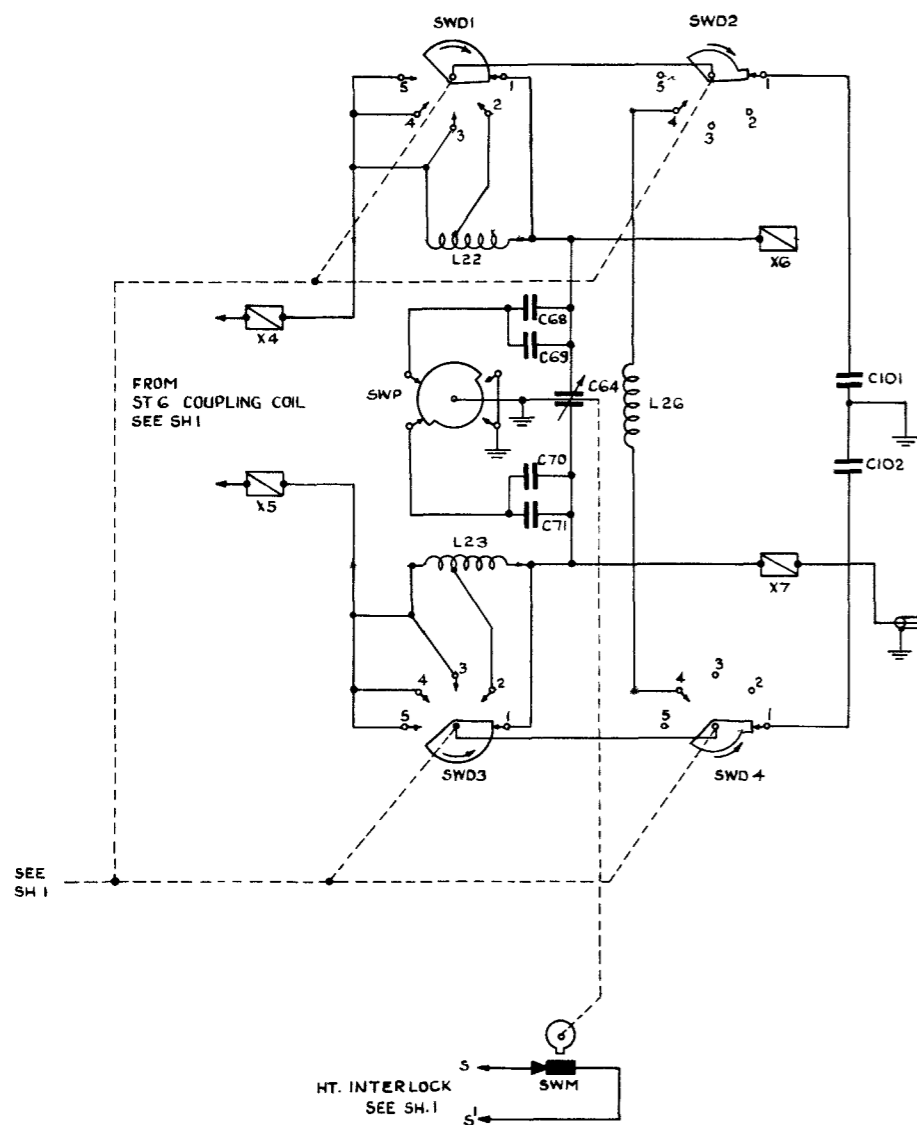

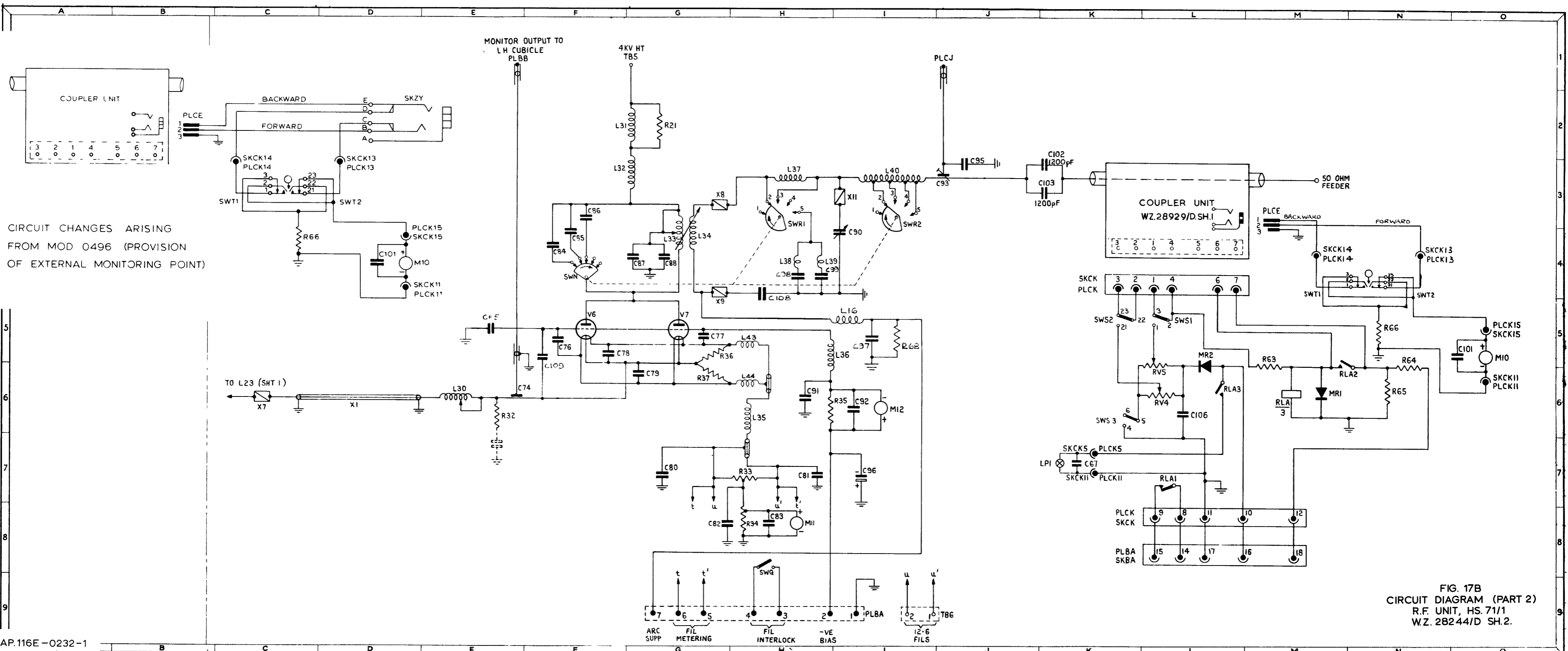

CIRCUIT CHANGES ARISING FROM MOD 0496 (PROVISION OF EXTERNAL MONITORING POINT)

FIG. 17B
CIRCUIT DIAGRAM (PART 2)
R.F. UNIT, HS. 71/1
W.Z. 28244/D SH.2.

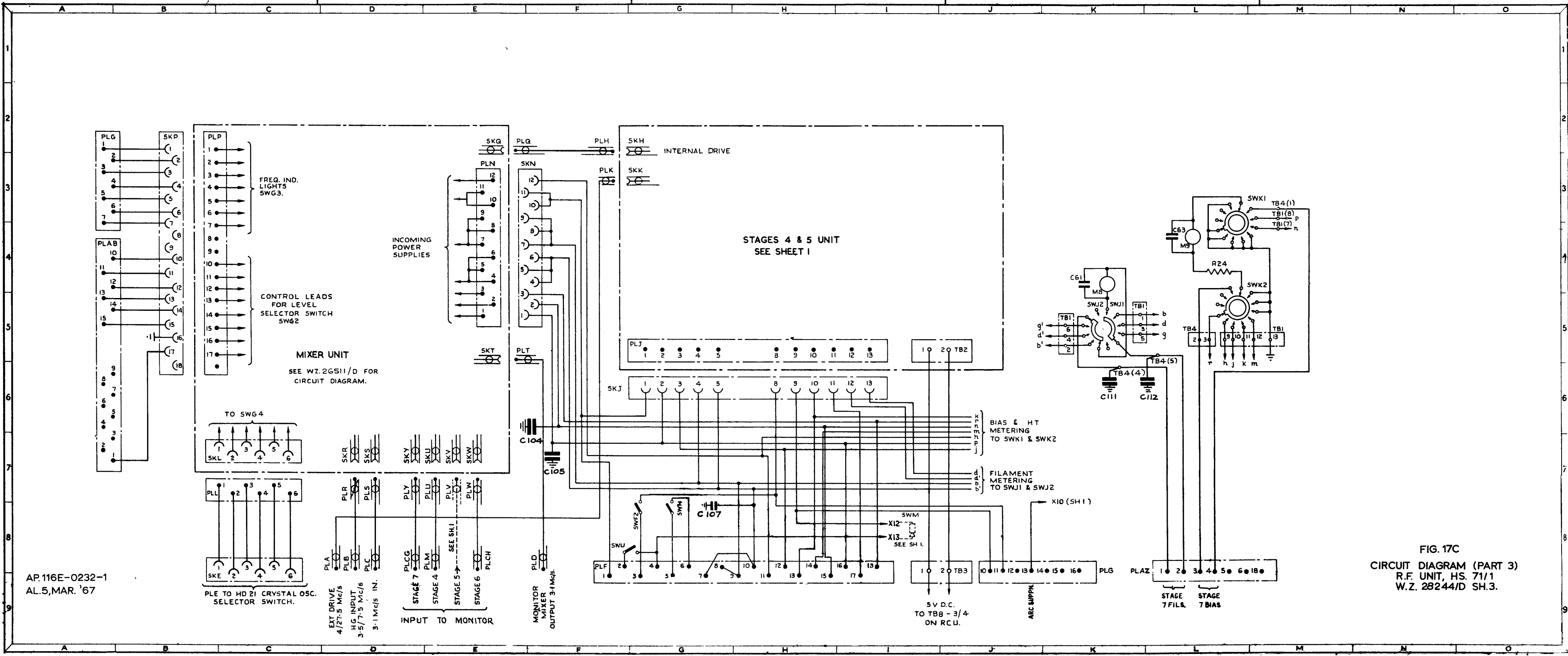

AP.116E-0232-1
AL.5,MAR. '67

FIG. 17C
CIRCUIT DIAGRAM (PART 3)
R.F. UNIT, HS. 71/1
W.Z. 28244/D SH.3.

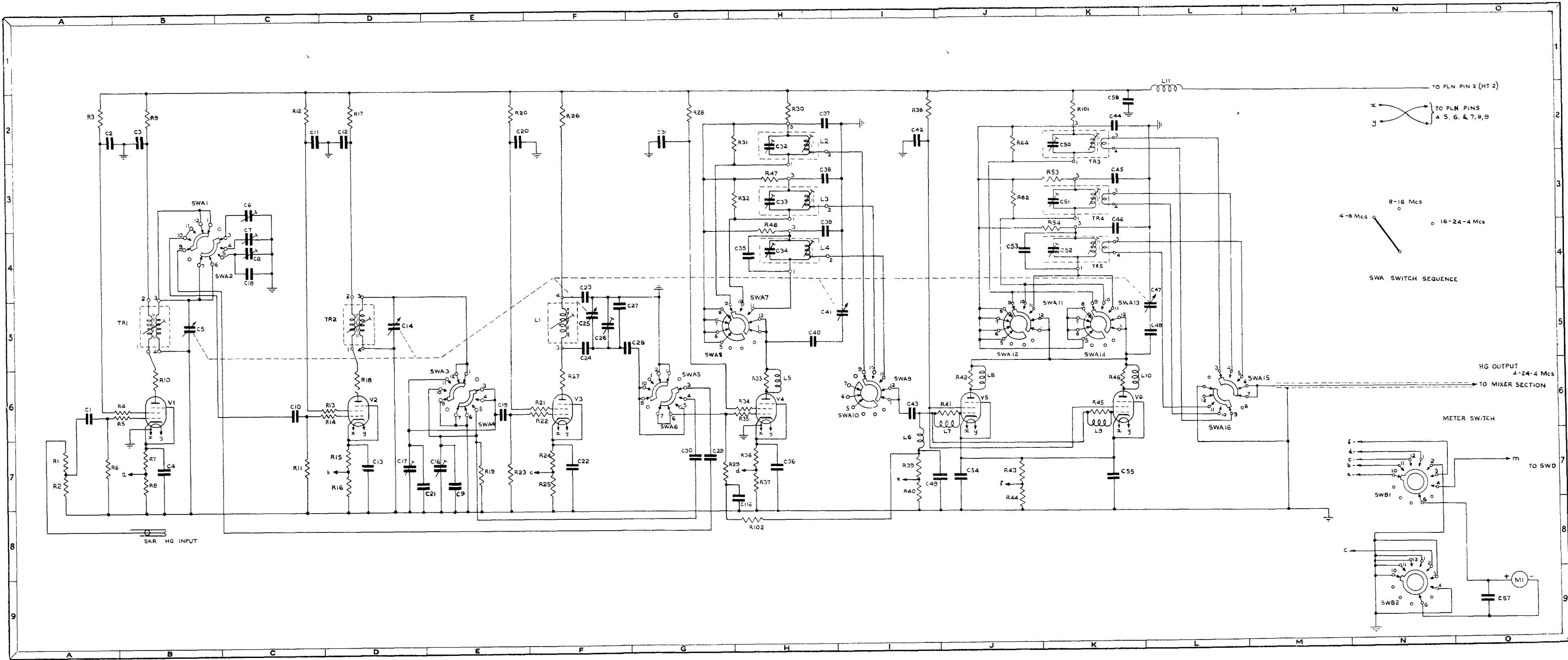

MIXER UNIT CIRCUIT DIAGRAM, PART 1
 WZ. 15041/D Sh. 1 Iss. 3)

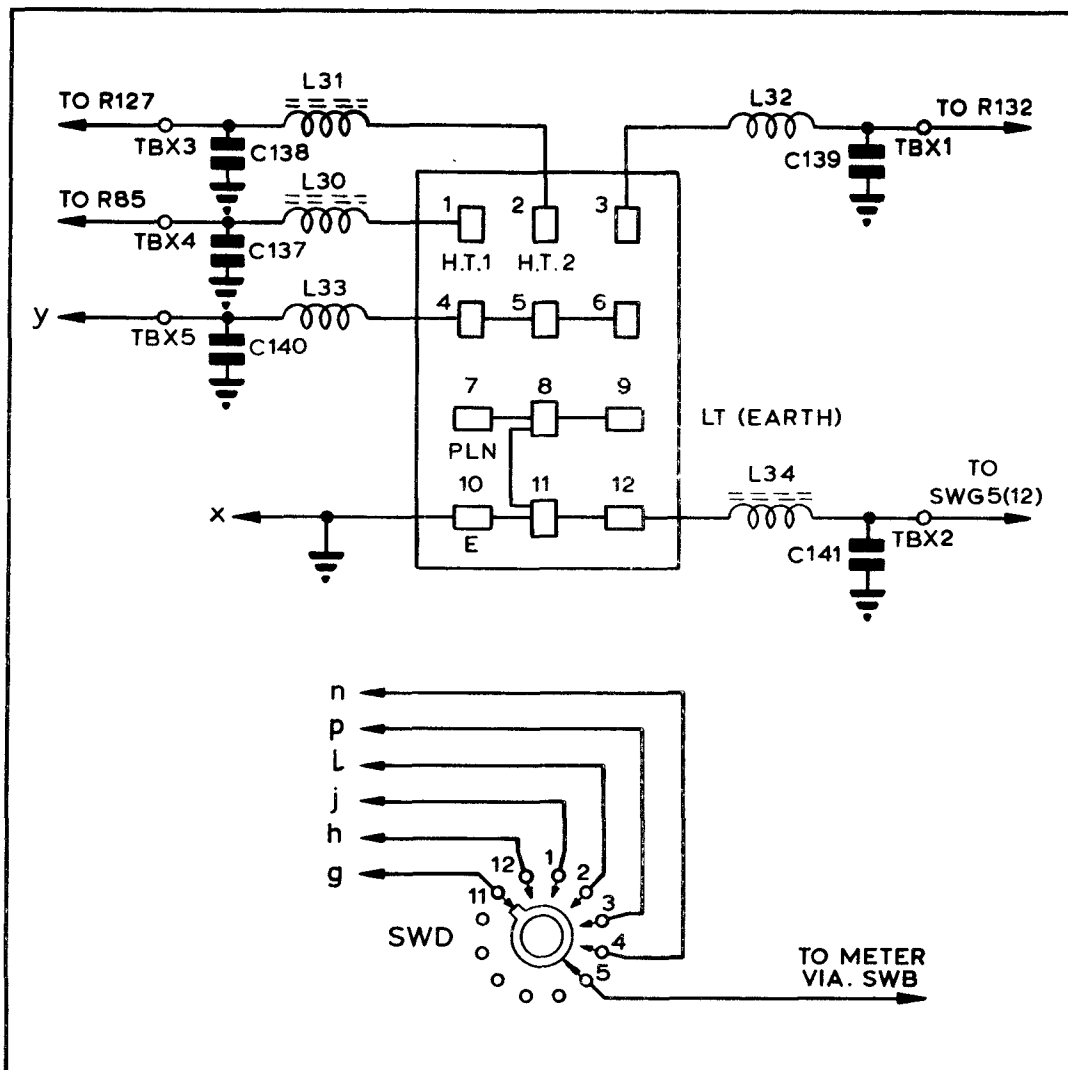

Mod. 0588 - Addition of R.F. Filter

The above diagram shows the change to Fig. 19 (top right-hand corner) arising from addition of filter under Mod. 0588 applicable to Transmitter, Radio, Type T. 10197 (Marconi hS.71).

(To face Fig. 19).

A.P.116E-0232-1
AL.6, May, 1968

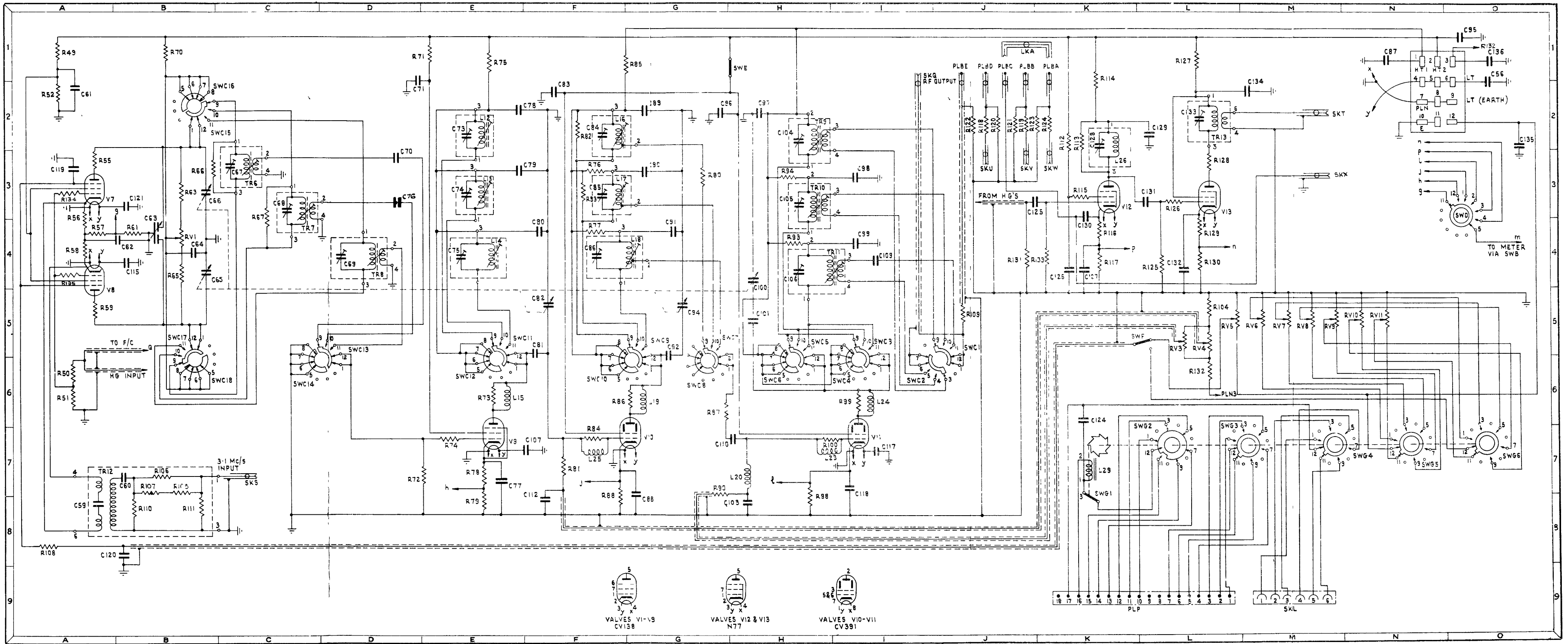

MIXER UNIT CIRCUIT DIAGRAM, PART 2
(WZ.15041/D Sh. 2 Iss. 5)

FIG.19A MIXER UNIT CIRCUIT DIAGRAM
PART 2 (HS.71A)

Changes arising from Modification 1312

(Monitoring of Transmitter, Radio, Type T.10197B when radiating on frequencies between 2.5 and 20 Mc/s).

Under Modification 1312 the 47 pfd capacitors C59 and C60 in TR.13 and L26 (grid refs. 2L and 3K on Fig. 19A) are removed.

It is then necessary, when using Monitor, R.F., Type 10160 (Ref. 10T/6625-99-943-6185) that the input applied to SKS should be 3.1 Mc/s. For information regarding frequency of the drive crystal (fxtal), refer to Supplement 3, Page 3, Section 3.3, and the table on the page facing Fig.1A in the main book.

(To face
Fig. 19A)

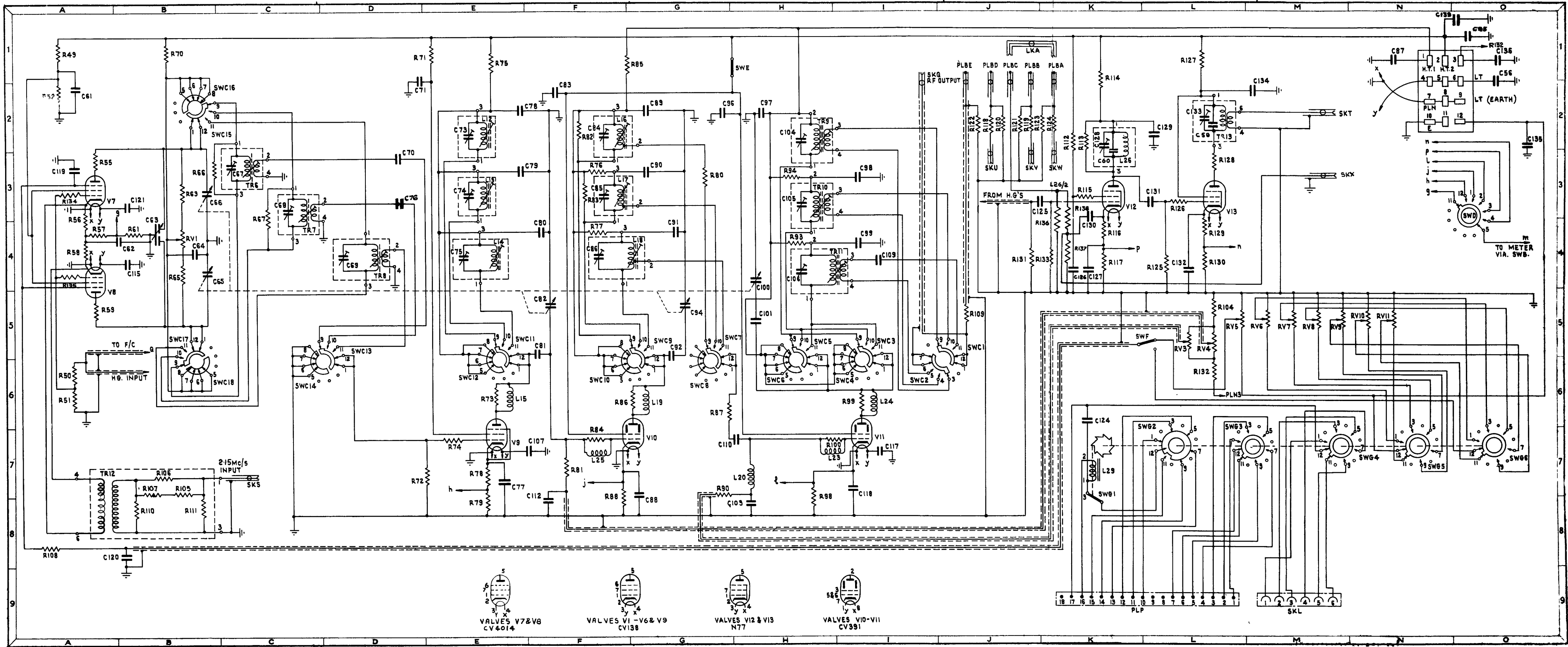

MIXER UNIT,
CIRCUIT DIAGRAM PART 2 (HS71A)
WZ.24356/D Sh.2 Iss.1

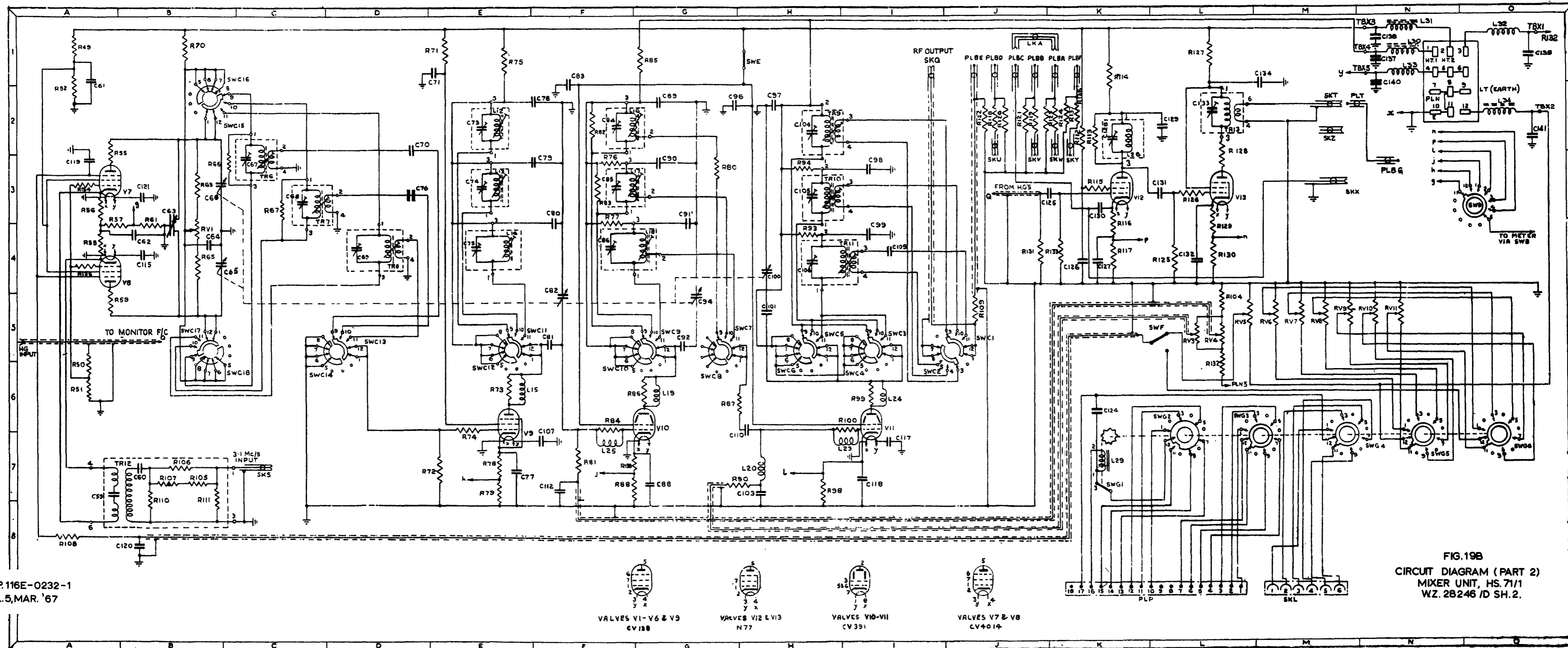
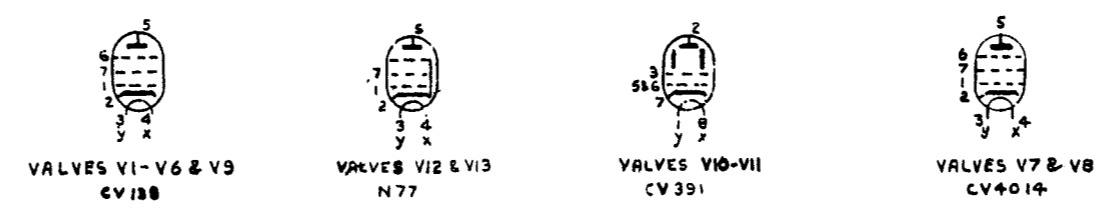
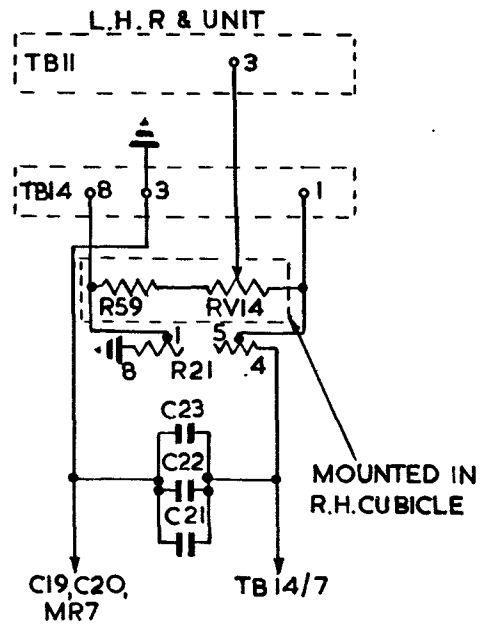
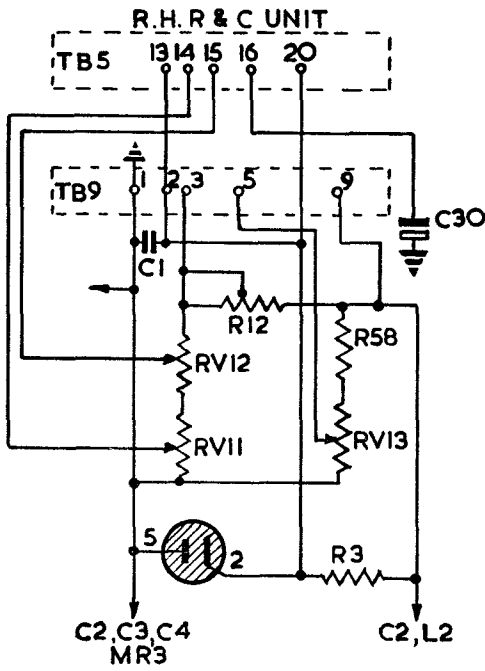

FIG.19B
 CIRCUIT DIAGRAM (PART 2)
 MIXER UNIT, HS. 71/1
 WZ. 28246 /D SH.2.

AP.116E-0232-1
 AL.5,MAR.'67





MOUNTED IN R.H. CUBICLE

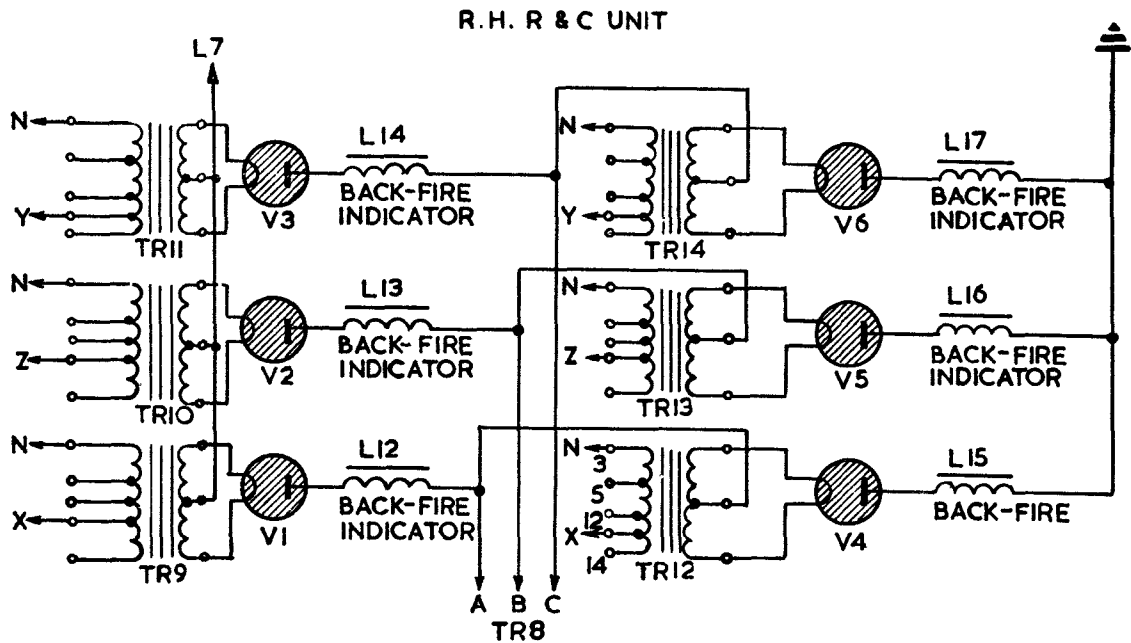

CIRCUIT CHANGES ARISING FROM
 MODIFICATION NO. 9784
 (Fitting of Back-fire Indicators
 and Remote Bias Control)

(To face
 Fig.20)

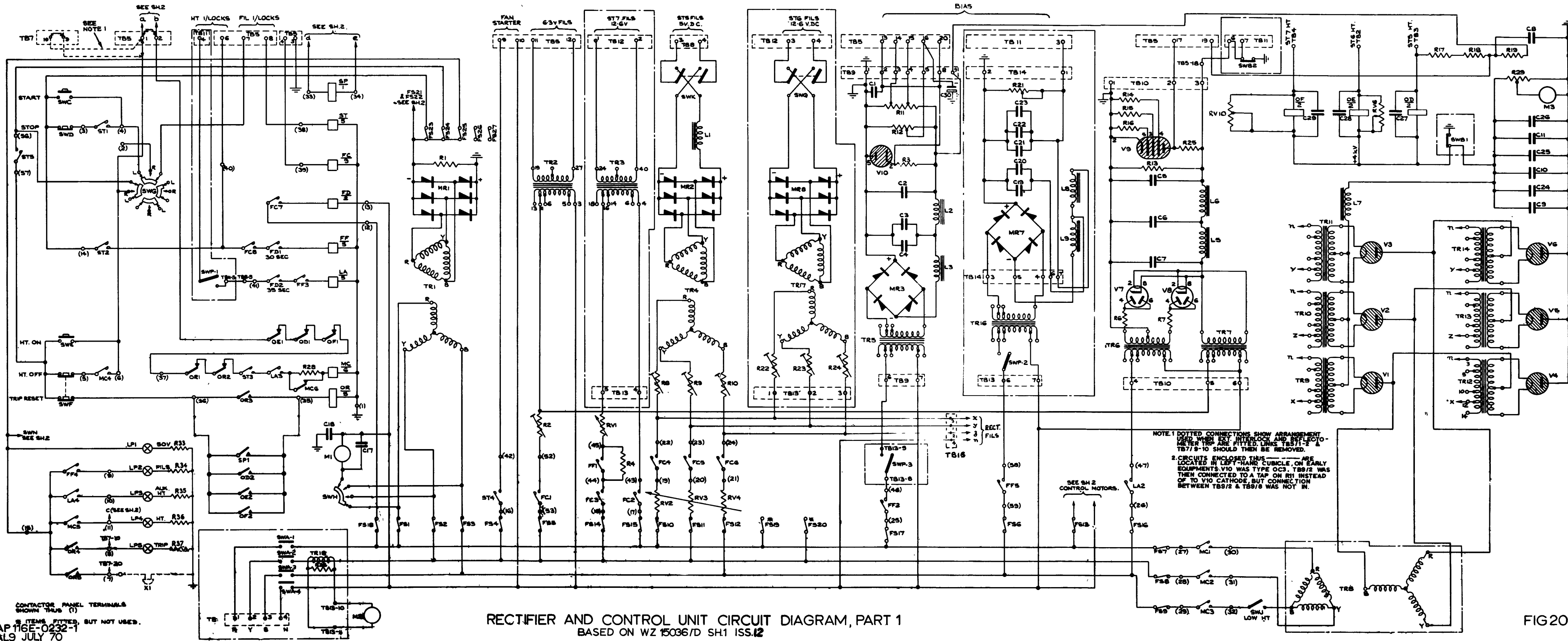

CONTRACTOR PANEL TERMINALS SHOWN THUS (T)

16 ITEMS FITTED, BUT NOT USED.

AP 116E-0232-1

AL9 JULY 70

RECTIFIER AND CONTROL UNIT CIRCUIT DIAGRAM, PART 1

BASED ON WZ 15036/D SH.1 ISS.12

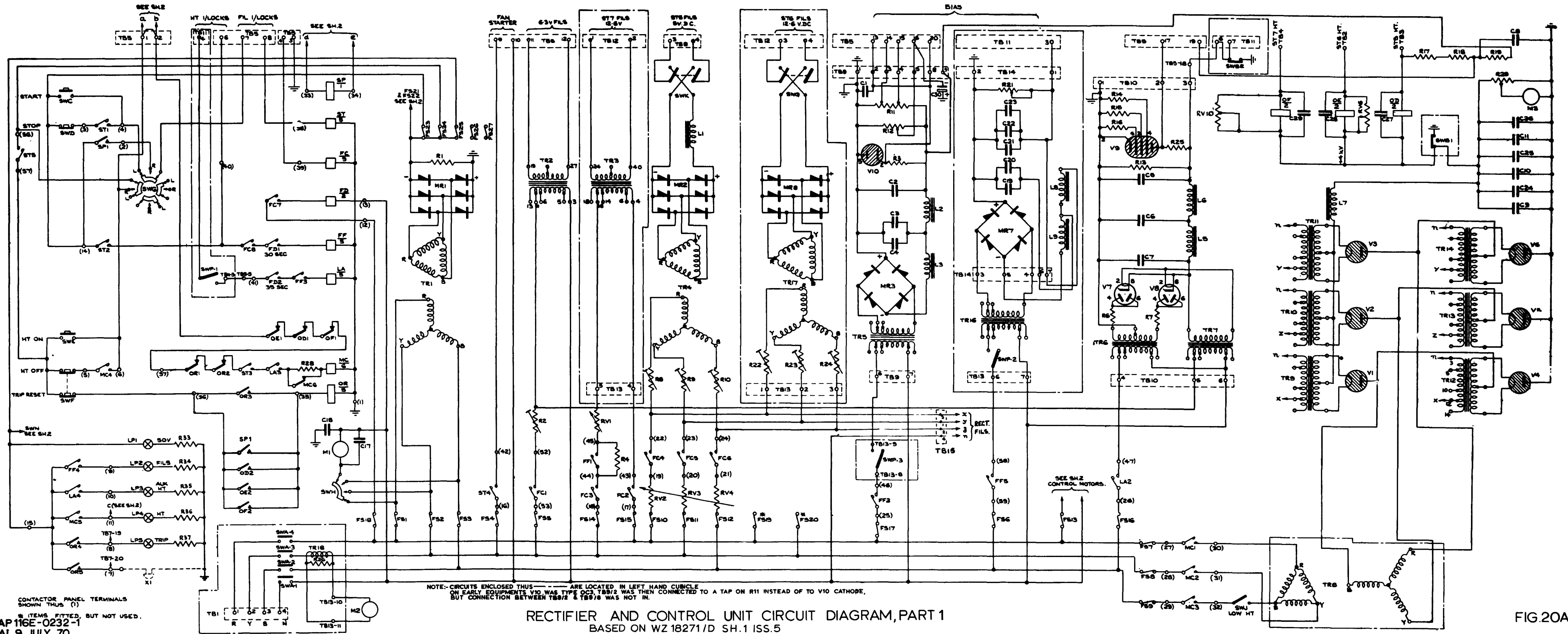

NOTE: CIRCUITS ENCLOSED THUS ARE LOCATED IN LEFT HAND CUBICLE ON EARLY EQUIPMENTS V10 WAS TYPE OC3, TB9/2 WAS THEN CONNECTED TO A TAP ON R11 INSTEAD OF TO V10 CATHODE, BUT CONNECTION BETWEEN TB9/2 & TB9/8 WAS NOT IN.

RECTIFIER AND CONTROL UNIT CIRCUIT DIAGRAM, PART 1
 BASED ON WZ 18271/D SH.1 ISS.5

CONTRACTOR PANEL TERMINALS SHOWN THUS (1)
 * ITEMS FITTED, BUT NOT USED.
 AP 116E-0232-1
 AL 9 JULY 70

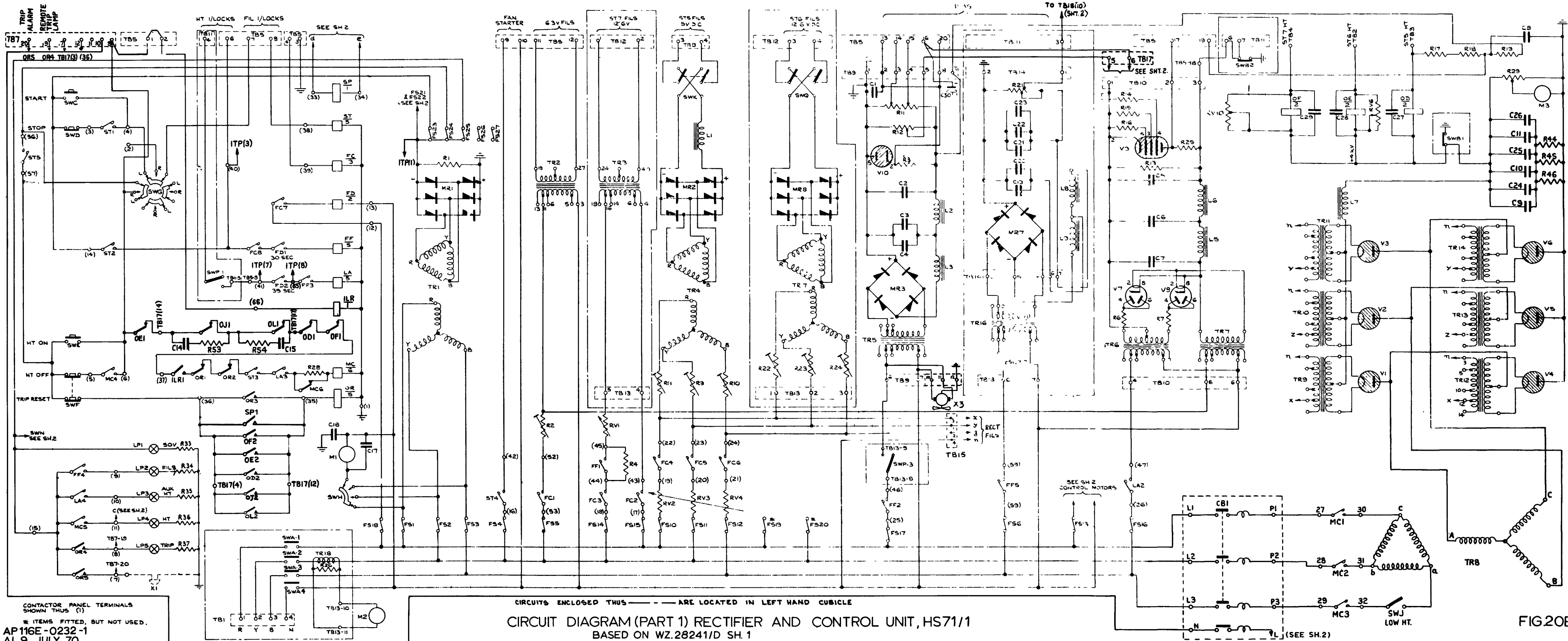

CIRCUIT DIAGRAM (PART 1) RECTIFIER AND CONTROL UNIT, HS71/1
 BASED ON WZ.28241/D SH. 1

FIG 20B

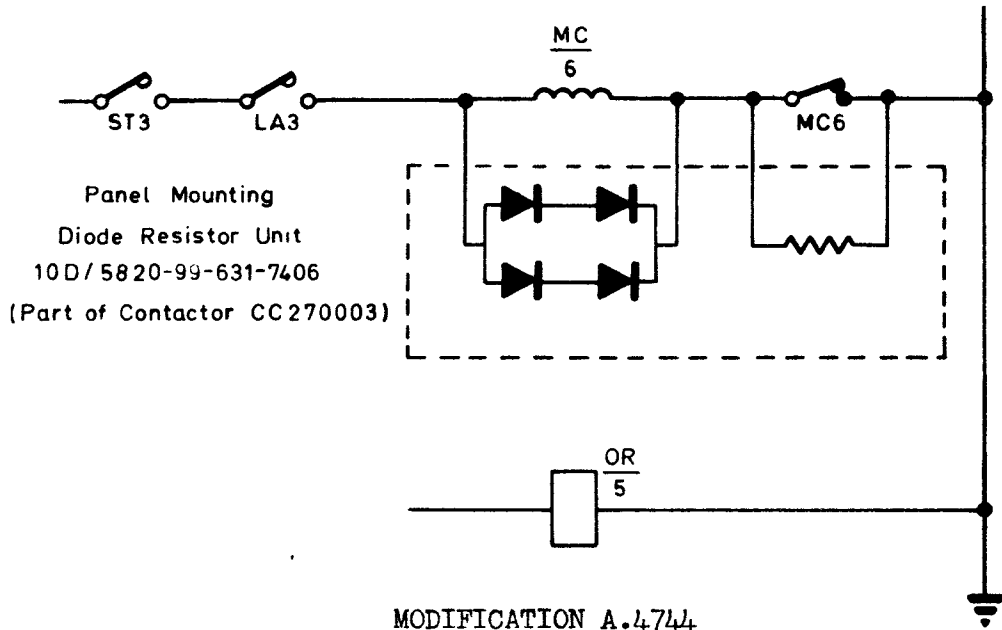

Panel Mounting
 Diode Resistor Unit
 10D/5820-99-631-7406
 (Part of Contactor CC270003)

MODIFICATION A.4744
 Contactor replacement

Applicable to all Rectifier and Control Units
 Refer to Figs. 20, 20A and 20B

Fig. 20C

THIS LINK FITTED FOR 71 TRANSMITTER ONLY.

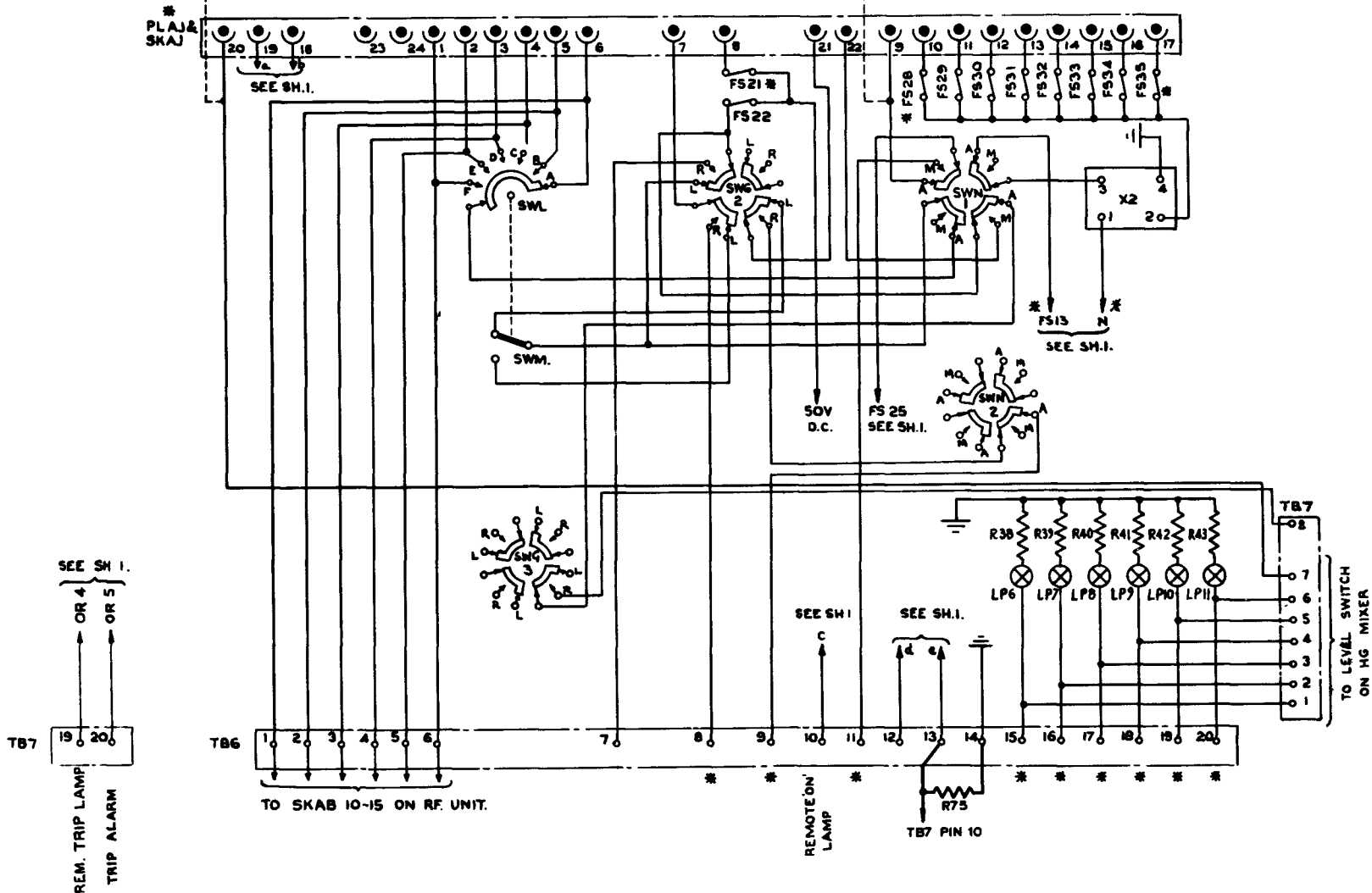

* ITEMS FITTED BUT NOT USED

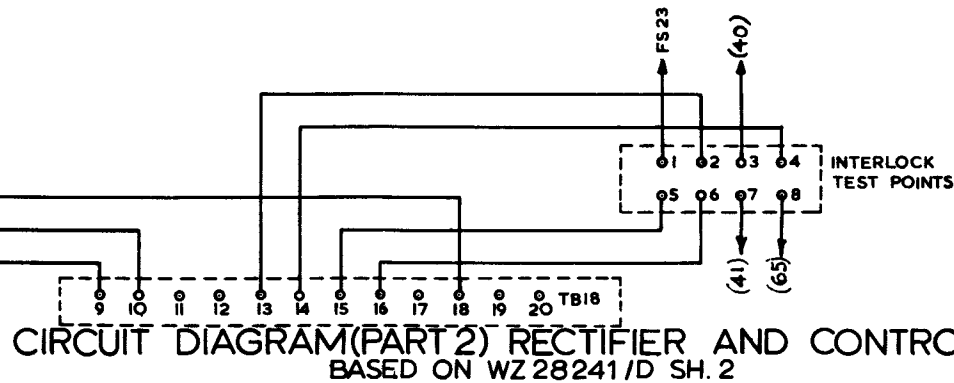
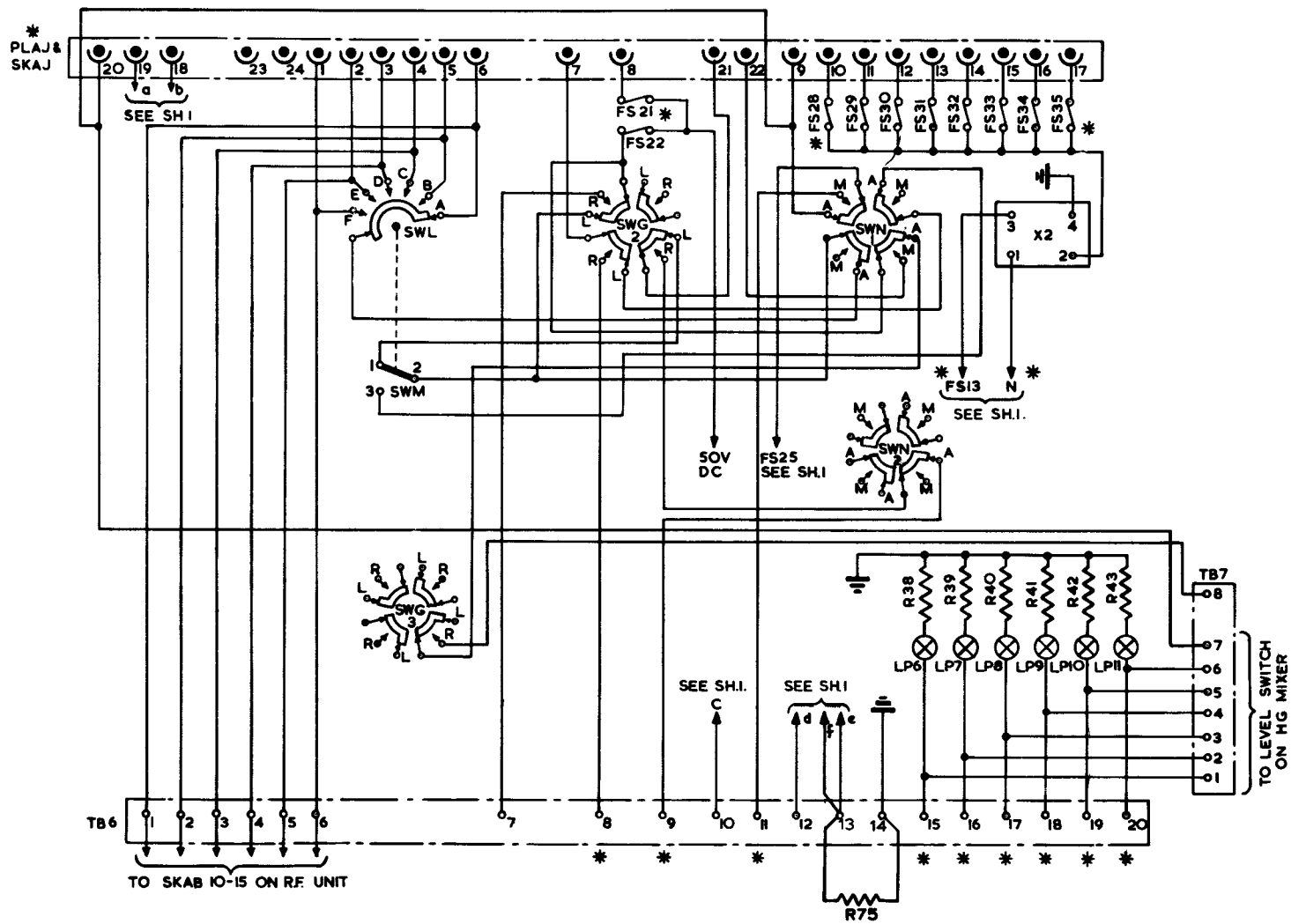
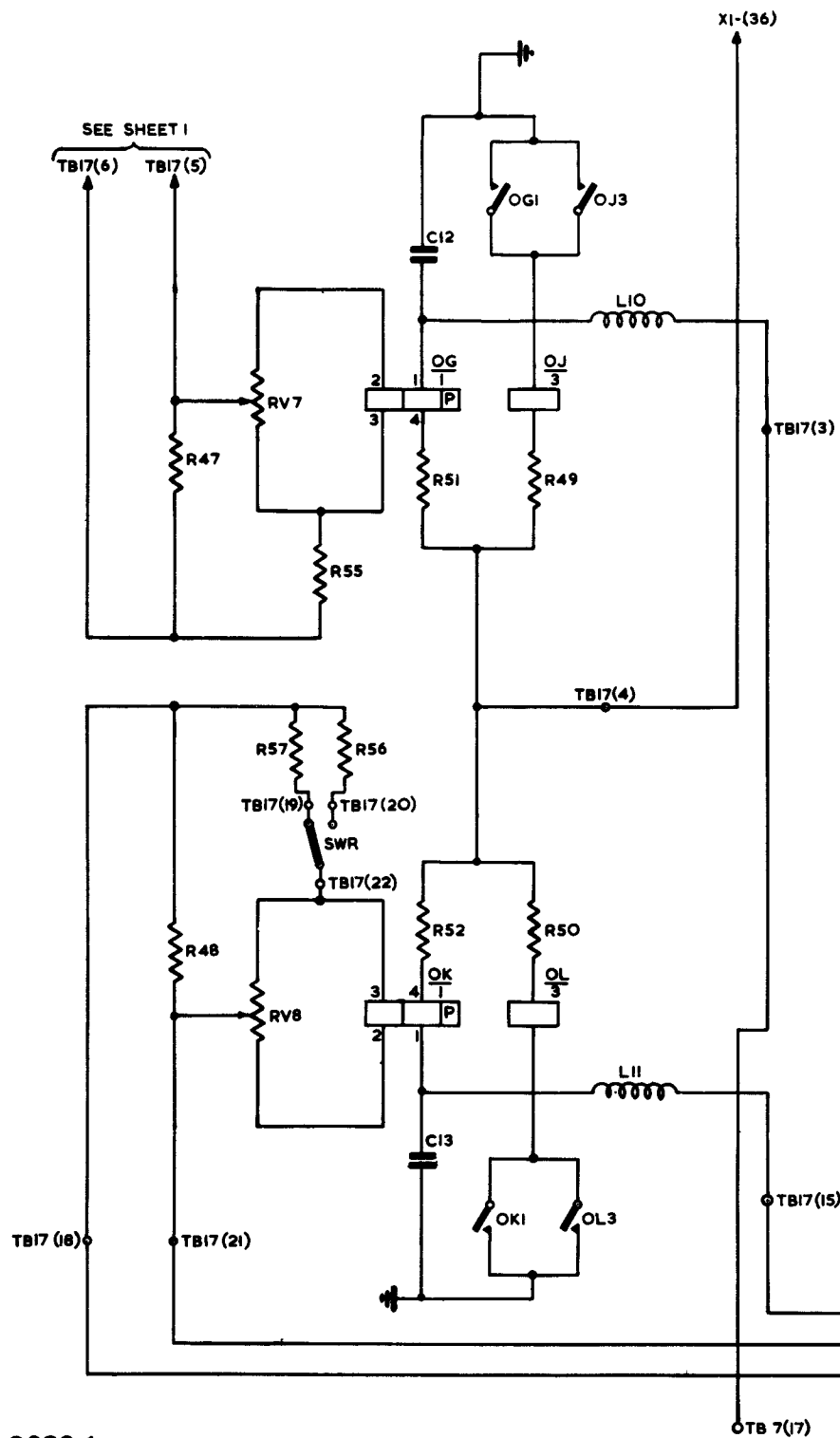

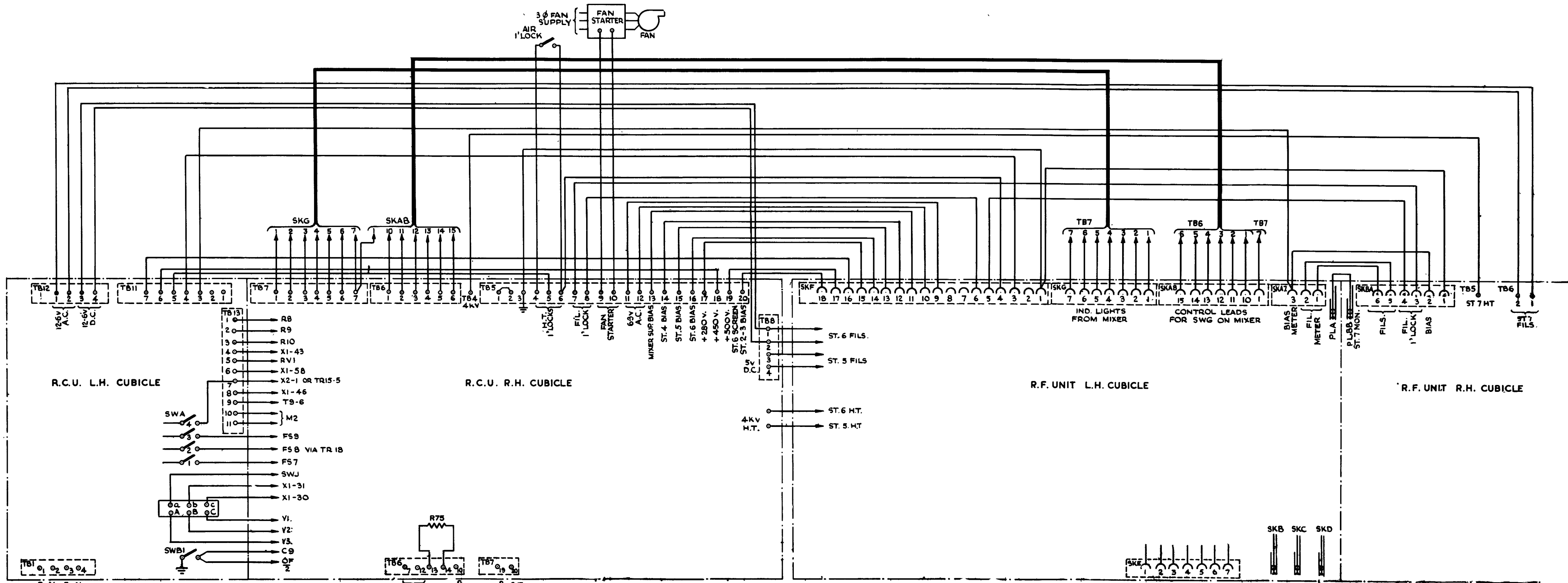

AP116E 0232-1
AL9 JULY 70

CABINET ASSEMBLY INTER-UNIT CONNECTIONS DIAGRAM
BASED ON WZ.15038/D SH.1 ISS.2

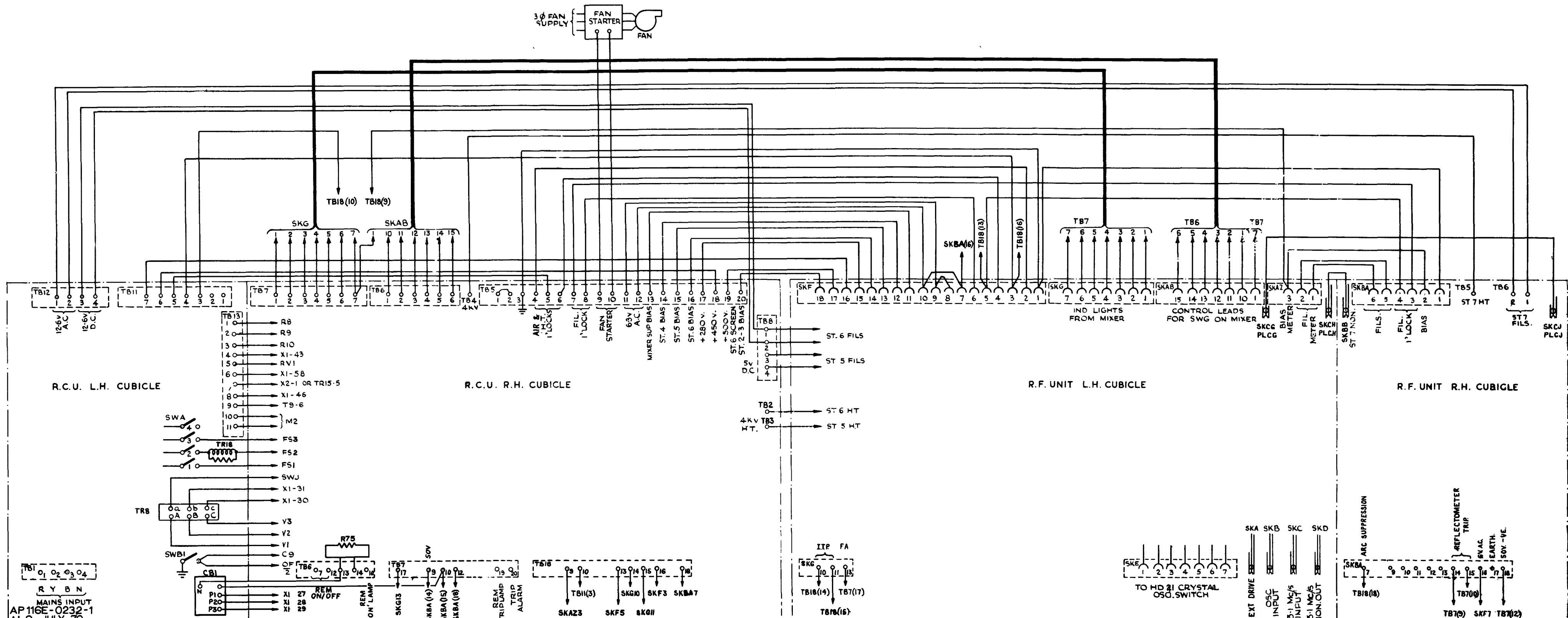

CONNECTION DIAGRAM INTER-UNIT HS71/1
 BASED ON WZ28243/D SH.1

FIG 22A

AP 116E-0232-1
 AL 9 JULY 70

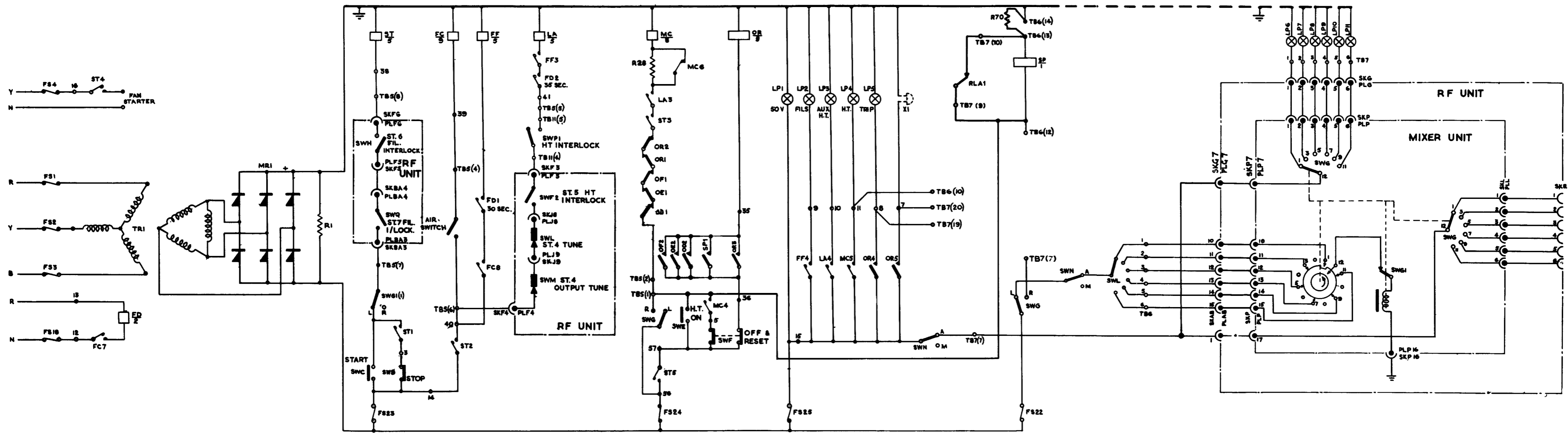

POSITIONS OF OTHER RELAY CONTACTS.

RELAY	CIRCUIT	RELAY	CIRCUIT
FC1	6-3V. FIL. SUPON/OFF	FF1	ST.7. FIL. SUP.
FC2	ST. 7 FIL. SUP. ON/OFF	FF2	BIAS ON/OFF
FC3		FF5	ST.7. BIAS ON/OFF
FC4	ST. 5. FIL. SUP.	LA2	AUX. H.T. ON/OFF
FC5	ON/OFF	MC1	MAIN H.T. SUP. ON/OFF
FC6		MC3	

OVERLOAD RELAYS IN MAIN H.T. SUPPLY.

RELAY	CIRCUIT
OD	ST 5 SUPPLY
OE	ST 6 SUPPLY
OF	ST 7 SUPPLY

AP116E-0232-1
AL9 JULY 70

TRANSMITTER TYPE HS71 CONTROL CIRCUIT DIAGRAM
BASED ON WZ16491/D SH.1 ISS.5

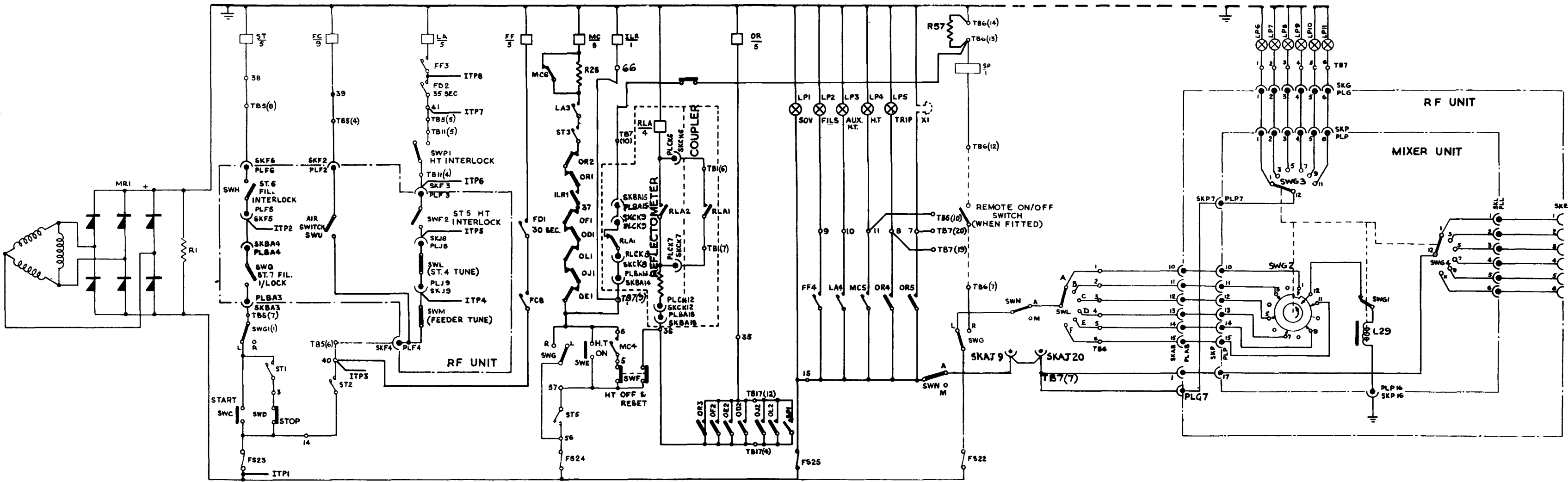
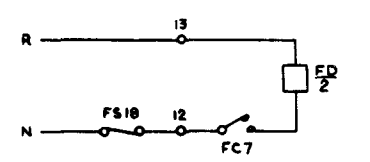
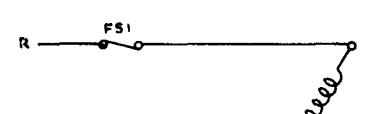
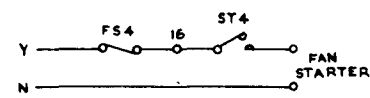

POSITIONS OF OTHER RELAY CONTACTS.

RELAY	CIRCUIT	RELAY	CIRCUIT
FC1	6.3V. FIL. SUP. ON/OFF	FF1	ST. 7. FIL. SUP.
FC2	ST. 7. FIL. SUP. ON/OFF	FF2	BIAS ON/OFF
FC3		FF5	ST. 7. BIAS ON/OFF
FC4	ST. 5. FIL. SUP.	LA2	AUX. H.T. ON/OFF
FC5	ON/OFF	MC1	MAIN H.T. SUP. ON/OFF
FC6		MC2	
		MC3	

CONTROL CIRCUIT DIAGRAM HS71/1
BASED ON WZ. 28346/D SH. 1

OVERLOAD RELAYS IN MAIN H.T. SUPPLY.

RELAY	CIRCUIT
OD	ST. 5. SUPPLY
OE	ST. 6. SUPPLY
OF	ST. 7. SUPPLY
OG (a)	ARC SUPPRESSION } ST. 6
OG (b)	
OJ	OG SLAVE
OK (a)	ARC SUPPRESSION } ST. 7
OK (b)	
OL	OK SLAVE
RLA.	FEEDER REFLECTOMETER

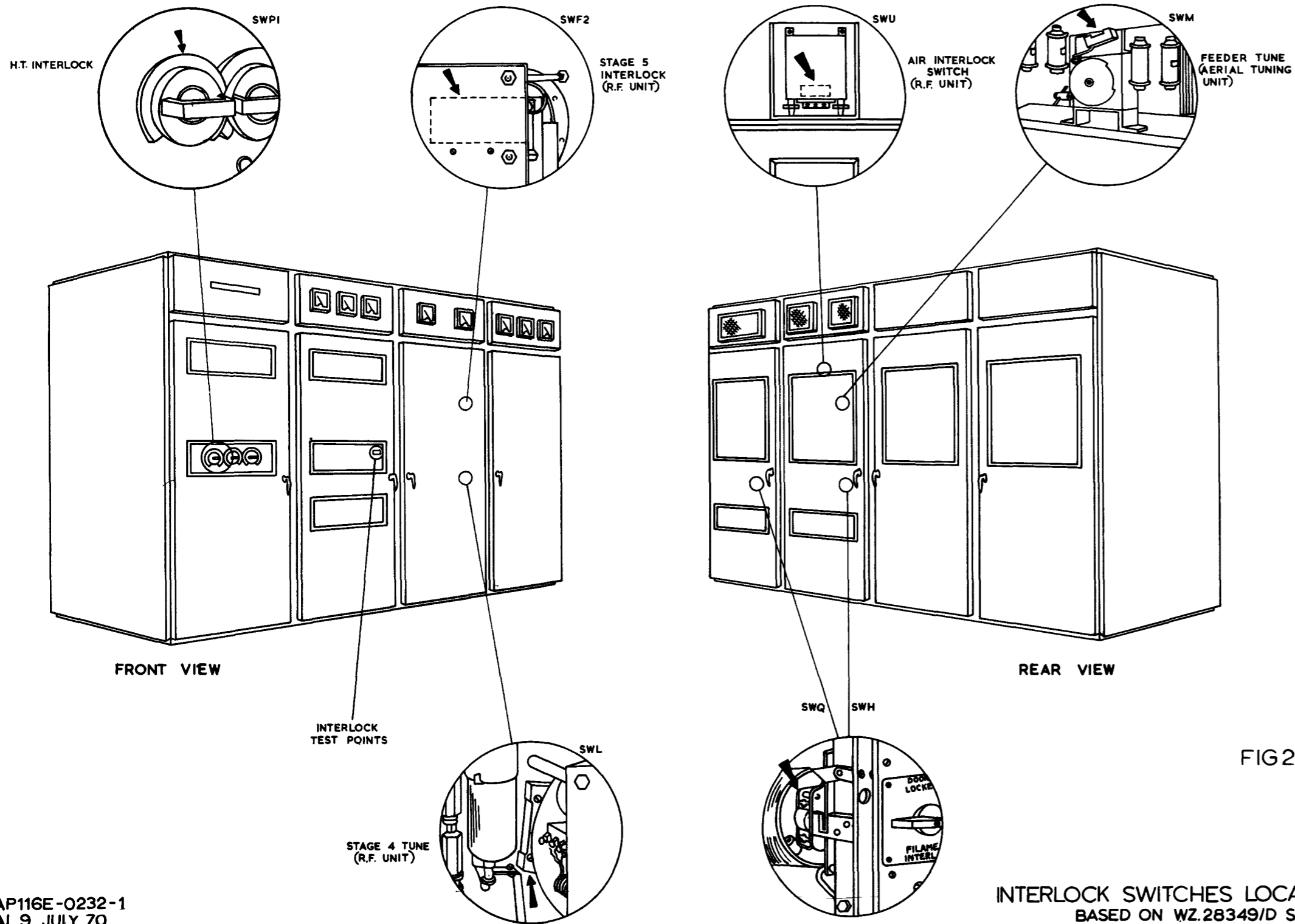
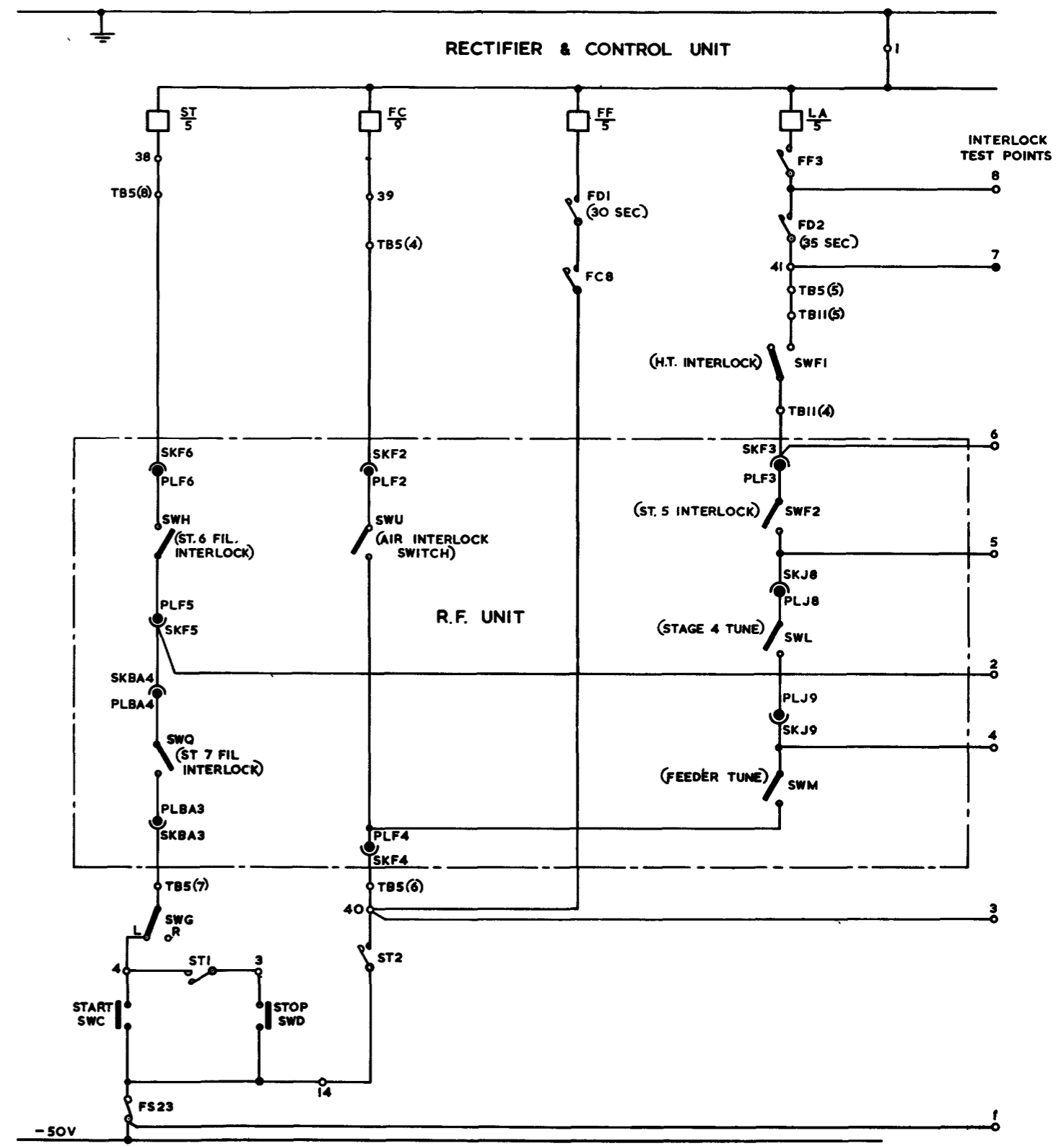
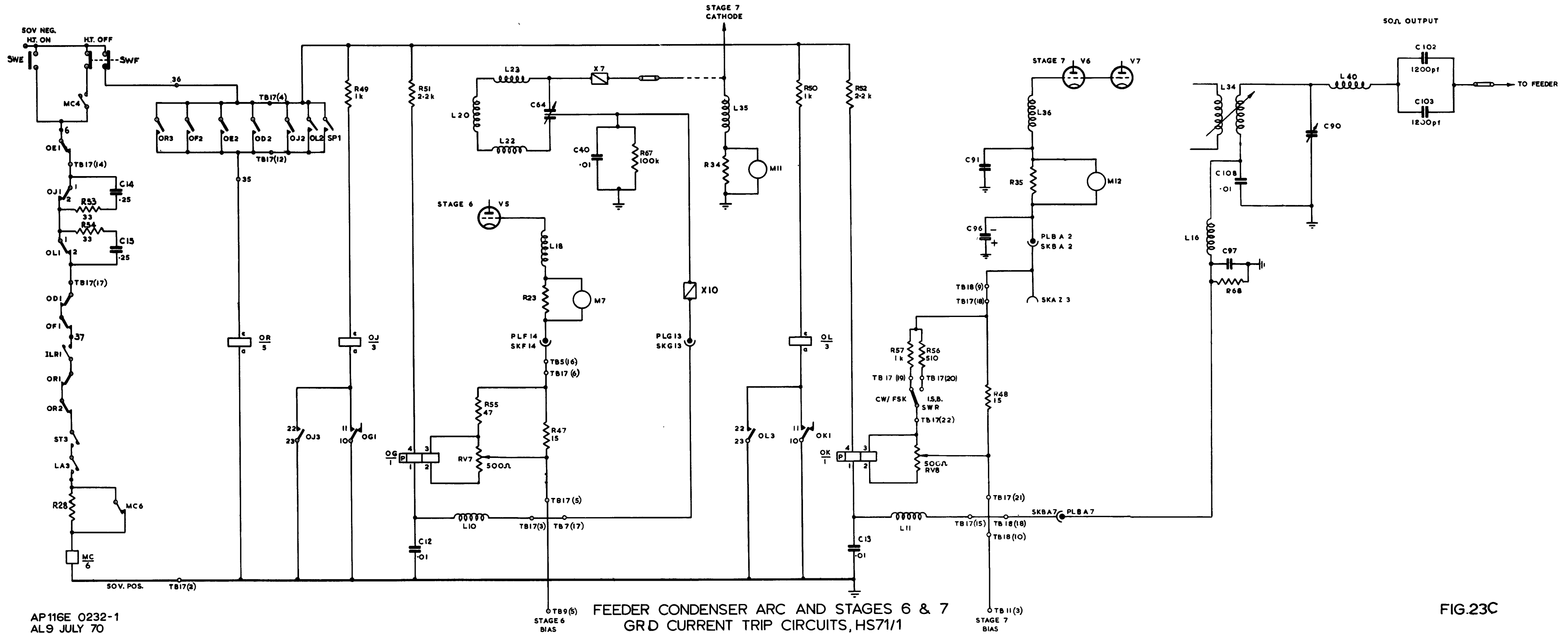

FIG 23B

INTERLOCK SWITCHES LOCATION, HS71/1
 BASED ON WZ.28349/D SH.1





AP116E 0232-1
AL9 JULY 70

FEEDER CONDENSER ARC AND STAGES 6 & 7
GRD CURRENT TRIP CIRCUITS, HS71/1

FIG.23C

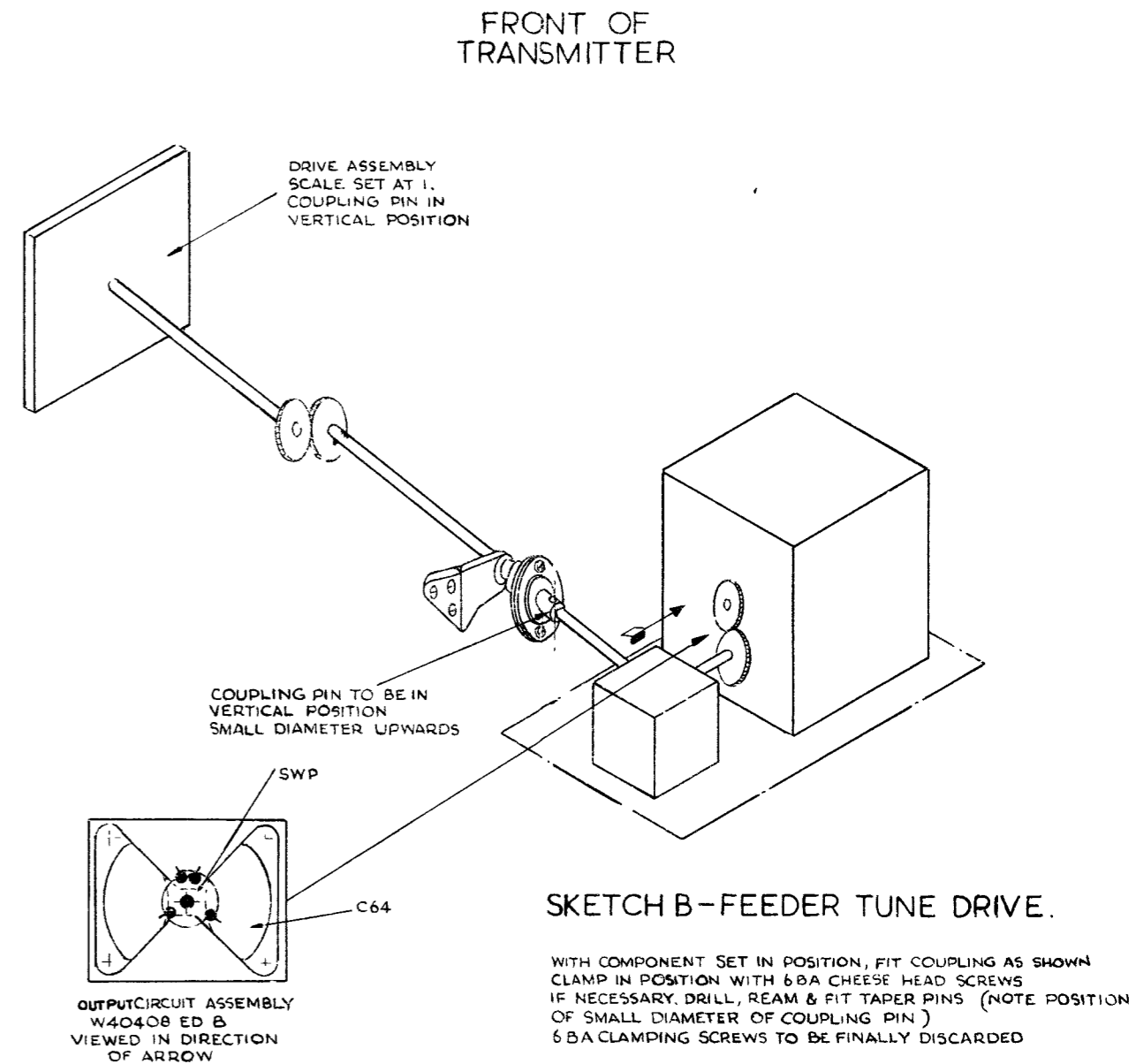
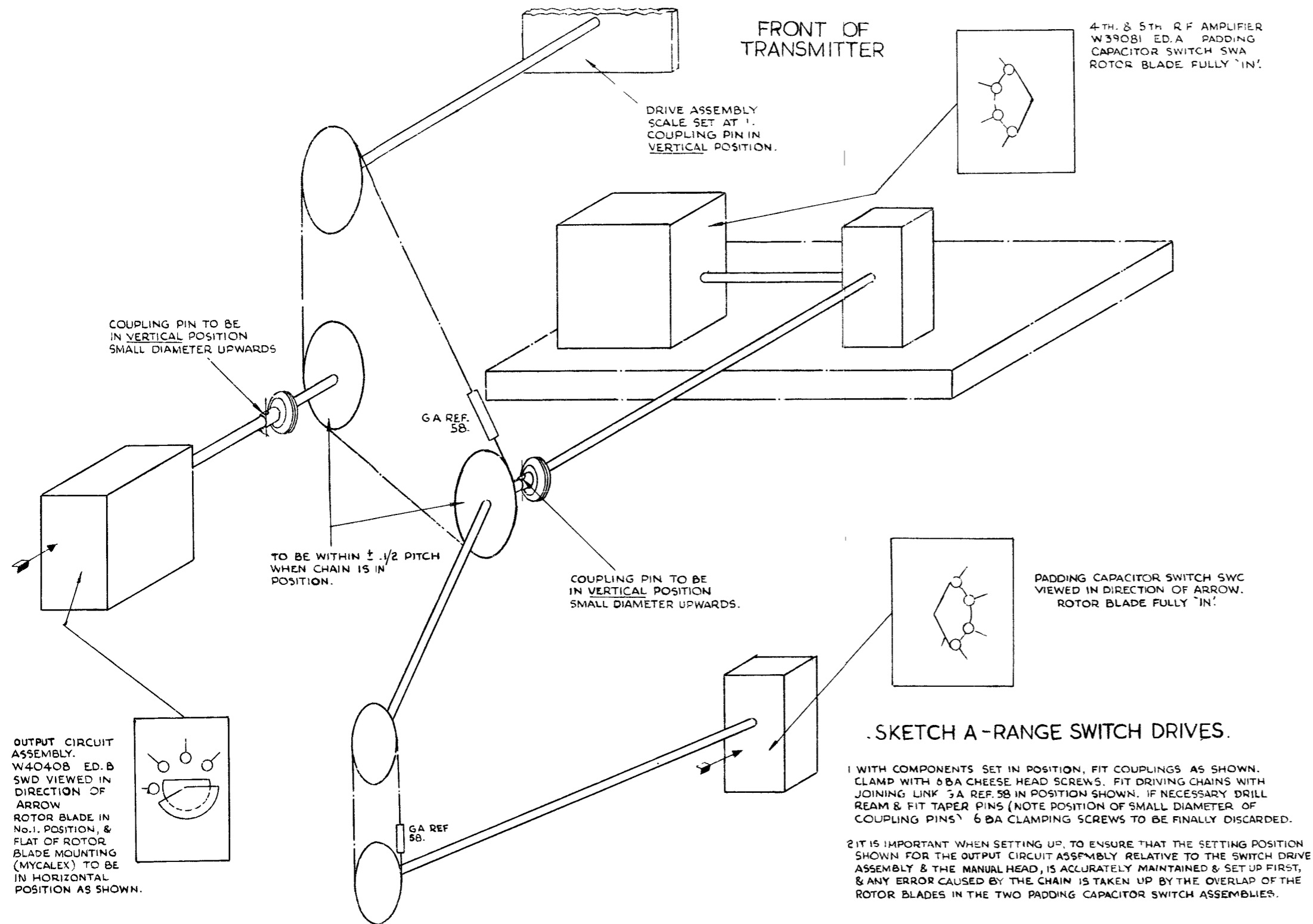

MECHANICAL DRIVE ASSEMBLIES, ASSEMBLY LAYOUT
(WZ. 16492/D Sh. 1 Iss. 2)

BEFORE PROCEEDING WITH PINNING ENSURE THAT CAPACITORS ARE IN STEP 10 THEY ARE BOTH IN THE MAX ANTICLOCK POSITION WHEN THE GEARS ARE MESHED. (CARE MUST BE TAKEN NOT TO EXCEED THE NORMAL LIMITS OF TRAVEL AS THIS WILL CAUSE THE CLUTCHES TO SLIP)

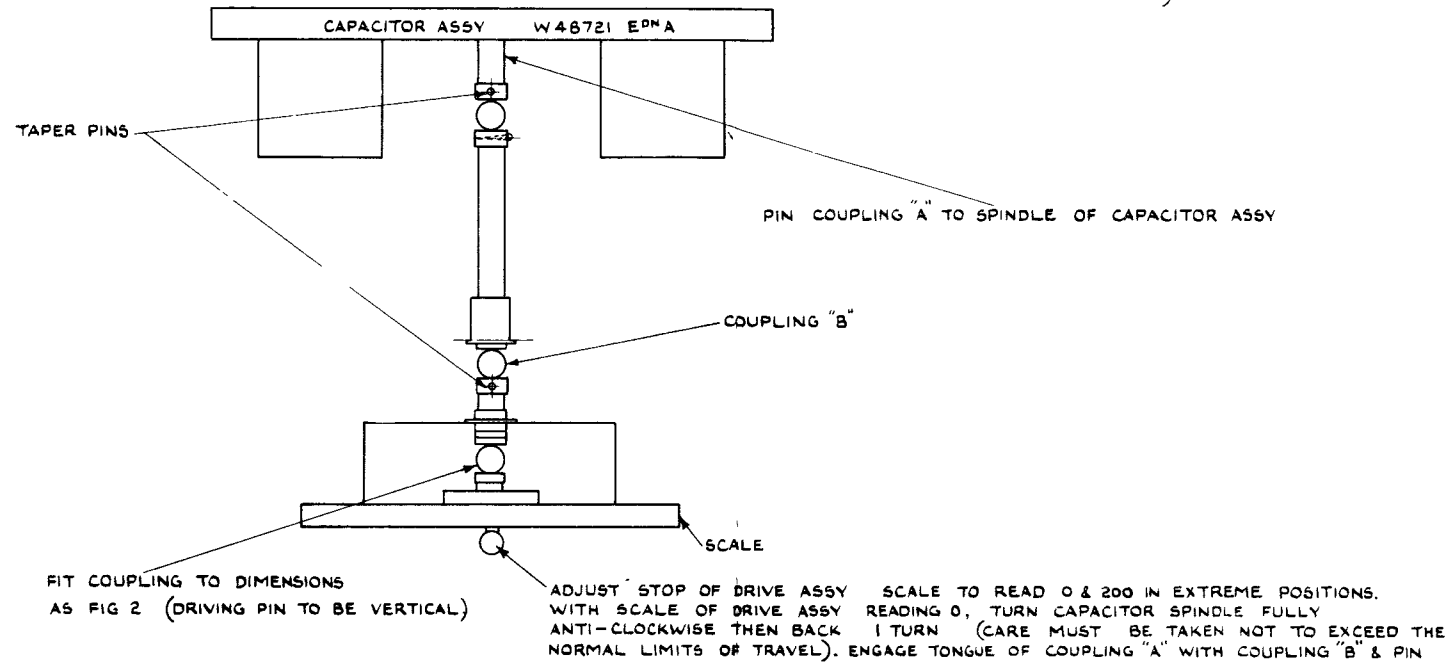

PINNING INSTRUCTIONS FOR CAPACITOR AND DRIVE

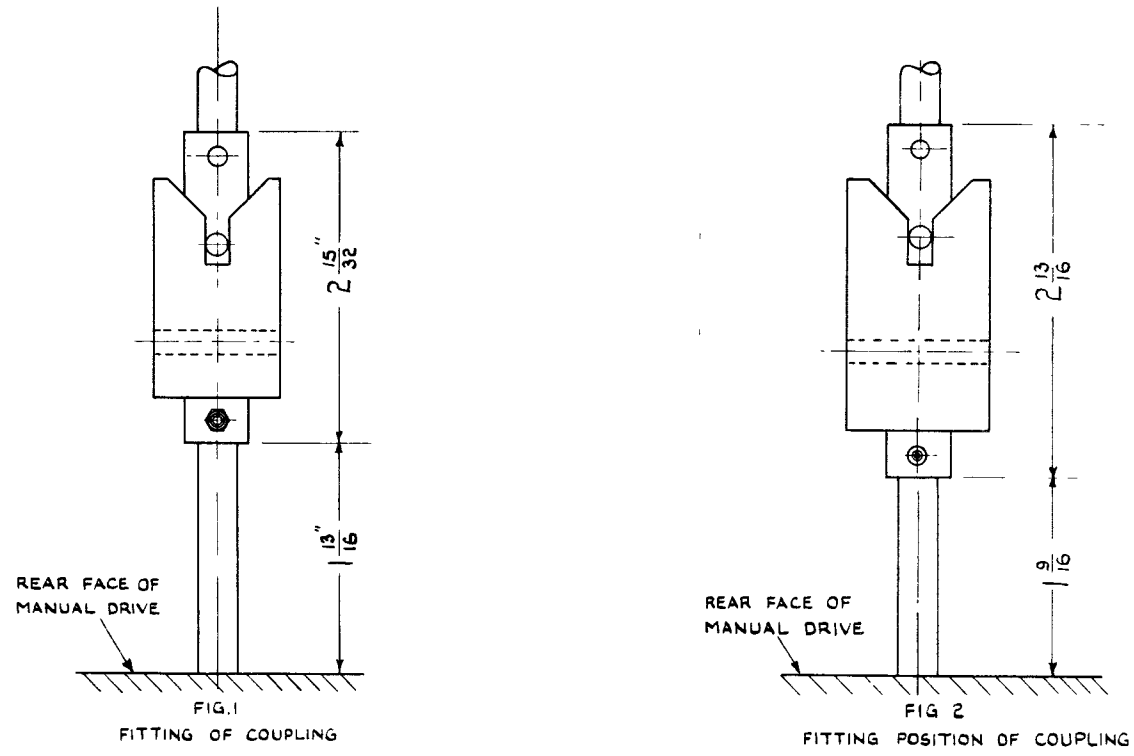

THE TWO ANGLES SHOWN ON WHICH THE OUTPUT CIRCUIT ASSY. SUPPORT BAR IS MOUNTED TO BE ADJUSTED SO THAT CONTACT BLADES & CONTACTS & THE DRIVING SHAFTS LINE UP CENTRALLY. ALSO THAT THE CLEARANCE BETWEEN THE SUPPORT BAR THE FRAME & RUNNER ANGLES IS KEPT TO A MINIMUM. I.E SUFFICIENT CLEARANCE TO BE LEFT JUST TO ALLOW THE SUPPORT BAR TO BE WITHDRAWN

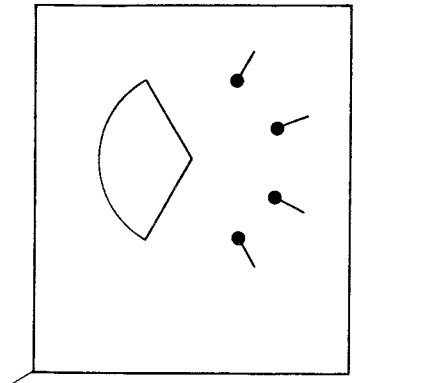
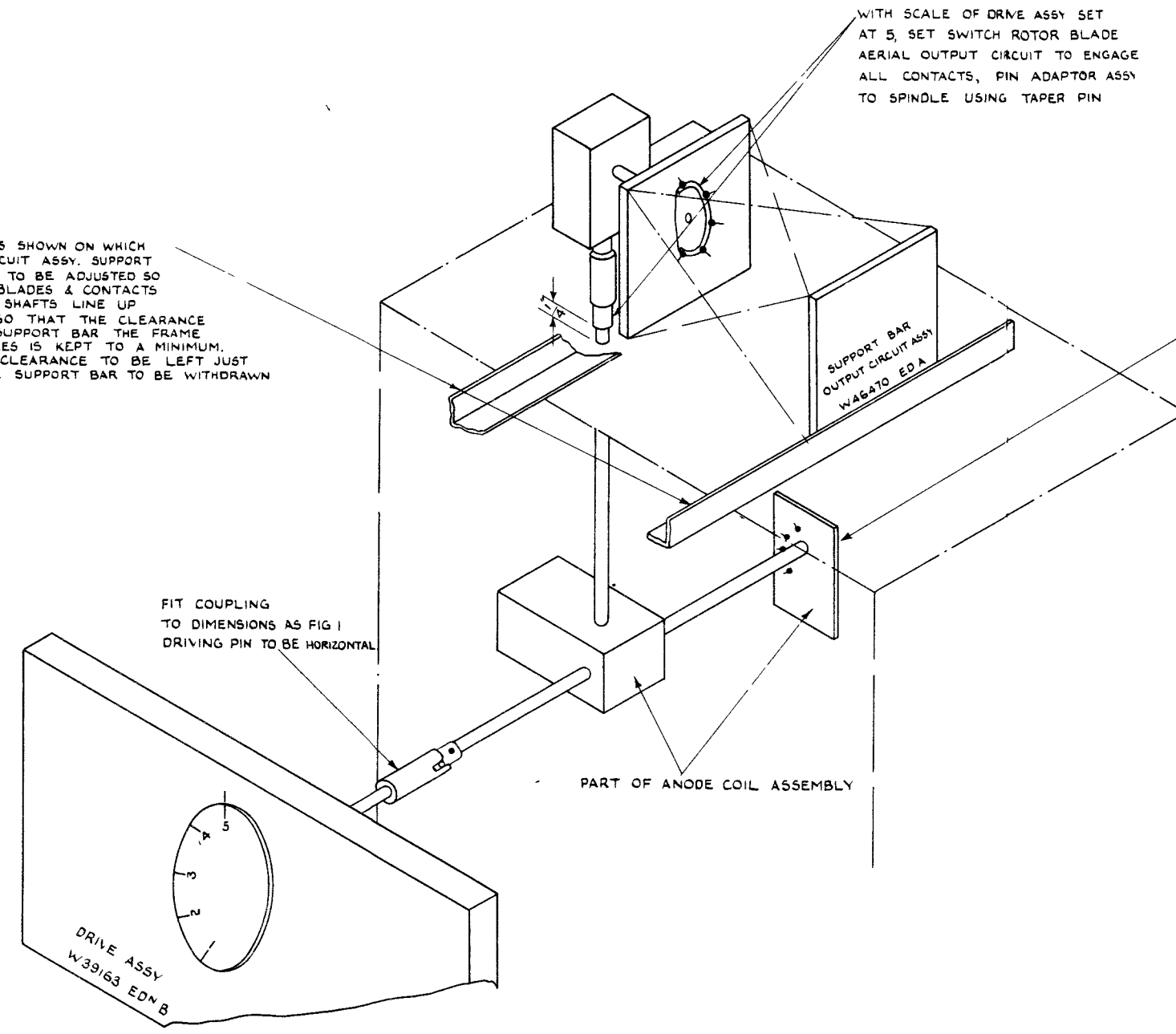

PADDING CAPACITOR SWITCH ROTOR BLADE TO BE IN POSITION SHOWN (NO CONTACTS MADE). CHECK BEFORE PINNING, WHEN ROTOR BLADE IS ENGAGING ALL CONTACTS, THAT THE OVERLAP AT EACH END IS EQUAL WHEN MANUAL DRIVE IS AT POSITION 1

9kW HF ISB TRANSMITTER

Type HS71

Technical Handbook T.3161/1

SUPPLEMENT 1

Marconi

© MARCONI'S WIRELESS TELEGRAPH COMPANY LIMITED

Chelmsford, Essex, England · Telephone: Chelmsford 3221 · Telex: 1953 · Telegrams: Expanse Chelmsford Telex

1963

Printed in Great Britain

FIRST AID IN CASE OF ELECTRIC SHOCK

DO NOT TOUCH THE VICTIM WITH YOUR BARE HANDS until the circuit is broken. **SWITCH OFF.** If this is not possible, **PROTECT YOURSELF** with dry insulating material and pull the victim clear of the conductor.

HOLGER NIELSEN METHOD OF ARTIFICIAL RESPIRATION

The instructions given below are approved by the Royal Life Saving Society.

1. Lay patient face downwards, head on one side, with forehead resting on the hands, placed one above the other.
2. Remove **FALSE TEETH, TOBACCO OR GUM**, from patient's mouth; make sure the **TONGUE IS FREE** by firm blows between the shoulders with the flat of the hand.
3. Kneel on one knee at the patient's head, one foot by the patient's elbow.
4. Place the palms of your hands on the patient's shoulder blades (See A).
5. Rock forward until arms are vertical. The pressure should be light and without force (22-30 lbs is sufficient). This should take $2\frac{1}{2}$ seconds (See B).



6. Release the pressure by allowing the hands to slide down the arms to the patient's elbows (approx. 1 second) then raise the patient's arms and shoulders slightly, pulling at the same time by swinging backwards (approx. $2\frac{1}{2}$ seconds) (See C). Lower the patient's arms (See D) and return your hands to the patient's shoulder blades.

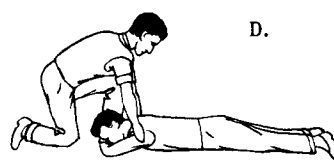
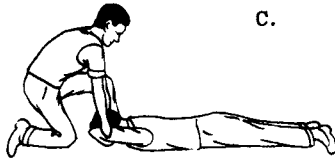

7. Repeat the movements, taking 7 seconds for each complete respiration.
8. While artificial respiration is continued, have someone else:-
 - (a) Loosen patient's clothing.
 - (b) Send for a doctor.
 - (c) Keep patient warm.
9. If patient stops breathing, continue artificial respiration. Four hours or more may be required.
10. **DO NOT GIVE LIQUIDS UNTIL PATIENT IS CONSCIOUS.**

TREATMENT FOR BURNS

If, as a result of electric shock, the patient is suffering from burns, the following treatment should be given without hindrance to artificial respiration:-

- (a) Remove clothing locally to enable the burn to be treated but do not break blisters.
- (b) Saturate burns with warm solution of one desertspoonful of bi-carbonate of soda to a pint of warm water, or a teaspoonful of salt to a pint of warm water.
- (c) Cover with lint soaked in a similar solution and bandage (lightly if blisters have formed).
- (d) If the above solutions are not available, cover with a sterile dressing.
- (e) Warm, weak, sweet tea may be given when the patient is able to swallow.

Further details of charts and book on Artificial Respiration may be obtained from:- The Royal Life Saving Society, 14 Devonshire Street, London W.1.

CONTENTS

	Page
1 INTRODUCTION	1
2 GENERAL DESCRIPTION	1
3 OPERATION AND TUNING	1
4 REPLACEMENTS	1

Illustrations

Component Layout

RF Unit (WZ.18082/D Sh.1)	Fig.9
RF Unit (WZ.18082/D Sh.4)	Fig.12

Circuit Diagrams

RF Unit (WZ.18081/D Sh.2)	Fig.17
---------------------------	--------

Block Diagrams

Transmitter HS71 (WZ.18526/D Sh.1)	Fig.1
------------------------------------	-------

Miscellaneous

Calibration Curves (WZ.18079/D Sh.3)	Fig.4
--------------------------------------	-------

9 kW HF ISB TRANSMITTER

TYPE HS. 71

1 INTRODUCTION

This Supplement is issued to cover the modification of a standard HS.71 Transmitter (600Ω output) to a 50Ω output impedance.

Table 1 at the end of the Supplement lists all the drawing and schedule amendments necessary for the revision of the main handbook.

2 GENERAL DESCRIPTION

The RF Unit is modified to provide a 50Ω unbalanced output by a re-arrangement of the output circuit from the coupling coil. One side of the coupling coil L34 is earthed, and is tuned by C90 with inductors L37, L38 and L39 in series and parallel on the higher frequency ranges. The feeder inductor L40 is a tapped coil which is shortened on the High frequency ranges by switch SWR2. Feeder Monitoring and metering facilities remain in their standard form.

NOTES: *C89 has been removed from the equipment and therefore all references to it in the standard handbook should be deleted.*

3 OPERATION AND TUNING

Throughout the tuning procedure the calibration curves in this supplement should be referred to and not those in the standard handbook.

The FEEDER TUNE capacitor spark-gap screws should be set $2\frac{1}{2}$ turns apart.

4 REPLACEMENTS

The Components List for the R.F.Unit, Schedule WZ.15039/A, should be re-numbered WZ.18081/A and the following amendments made:-

Page 73, C74

Total now 1.

Page 74, C89 and C90

C89 has been deleted, so retain information for

C90 and amend total to 1.

C93 and C94

delete As C74

insert C93, Pre-set Air Dielectric, -, -, -, W.52596/C, -, -, 2.
Sh.1.Ed.B.

Page 76, R56 and R58

R56 total now 2

R58 delete: As R56, insert: Not Used.

RV3.

Delete all information against RV3.

insert: RV3, Wirewound Potentiometer, 500Ω , ± 20 , $\frac{1}{2}W$

PC.67401/18, -, -, 1.

Page 78, L37, L38, L39, L40, L41, L42.

delete all information against all four components

insert:

L37, 8 turns, -, -, -, W.64464/B, -, -, 1.
Sh.1.Ref.1.

L38, 1 turn, -, -, -, W.64544, -, -, 1.
Sh.1.Ref.1.

L39, 1 turn, -, -, -, W.64544, -, -, 1.
Sh.1.Ref.2.

L40, 18 turns, -, -, -, W.64470, -, -, 1.
Sh.1.Ref.1.

Page 83, Item 1.

Delete all information

Page 83, Item 2.

delete: WIS.6425/B, AP.104342.
Sh.1.Ref.2.

insert: W.65675, -, -,
Sh.2.Ed.B.

Page 87. Item 92

delete: WIS.6425, AP.103514.
Sh.1.Ed.A

insert: W.65675, -, -, 1.
Sh.1.Ed.A

Drawings

Amend the title of the following drawings with the number shown.

Fig.2. WZ.15043/D Sh.1 to be WZ.18079/D Sh.1

Fig.3. WZ.15043/D Sh.2 to be WZ.18079/D Sh.2.

Fig.10. WZ.15040/D Sh.2 to be WZ.18082/D Sh.2.

Fig.11. WZ.15040/D Sh.3 to be WZ.18082/D Sh.3.

Fig.16. WZ.15039/D Sh.1 to be WZ.18081/D Sh.1.

Replace the following drawings:

Fig. 1

Fig. 4

Fig. 9

Fig.12

Fig.17

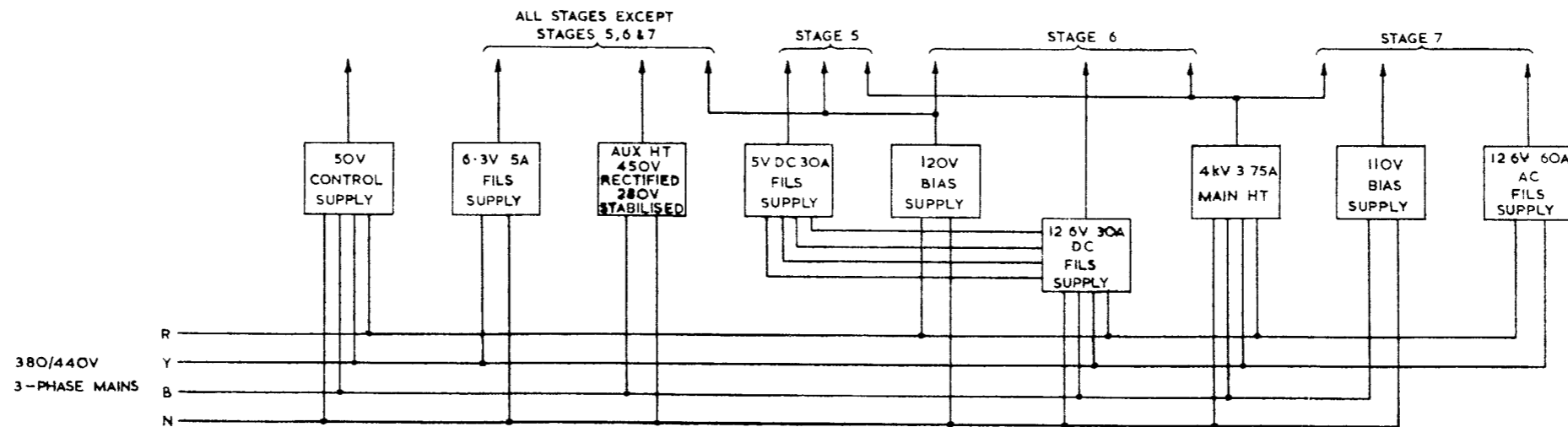
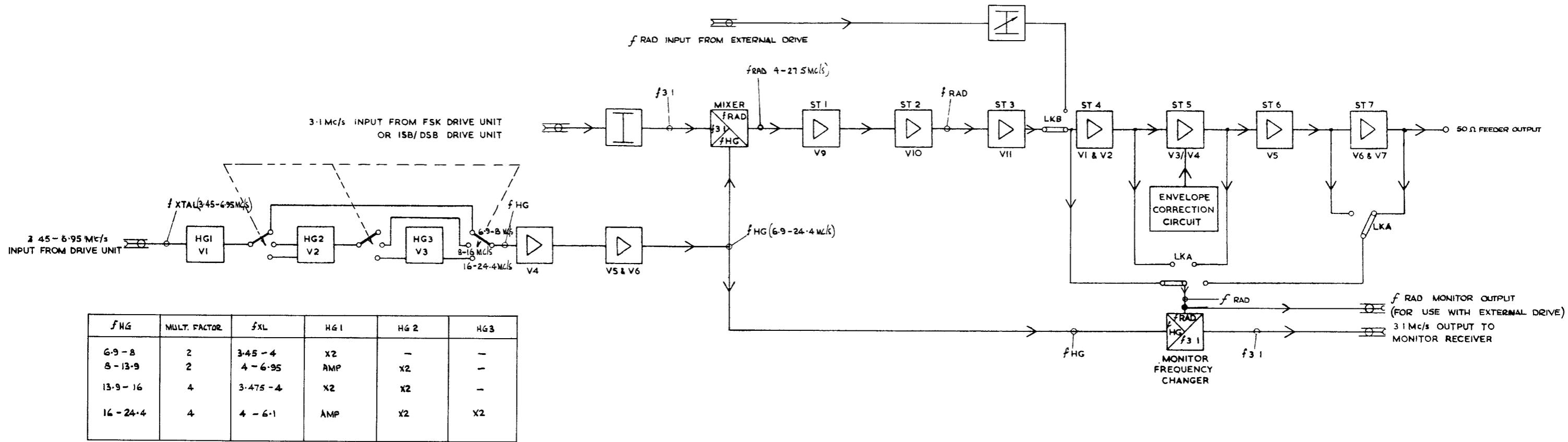

BLOCK DIAGRAM
HS71 TRANSMITTER
WZ.18526/D Sh.1 Iss.2

STAGE 7
CATHODE TUNE

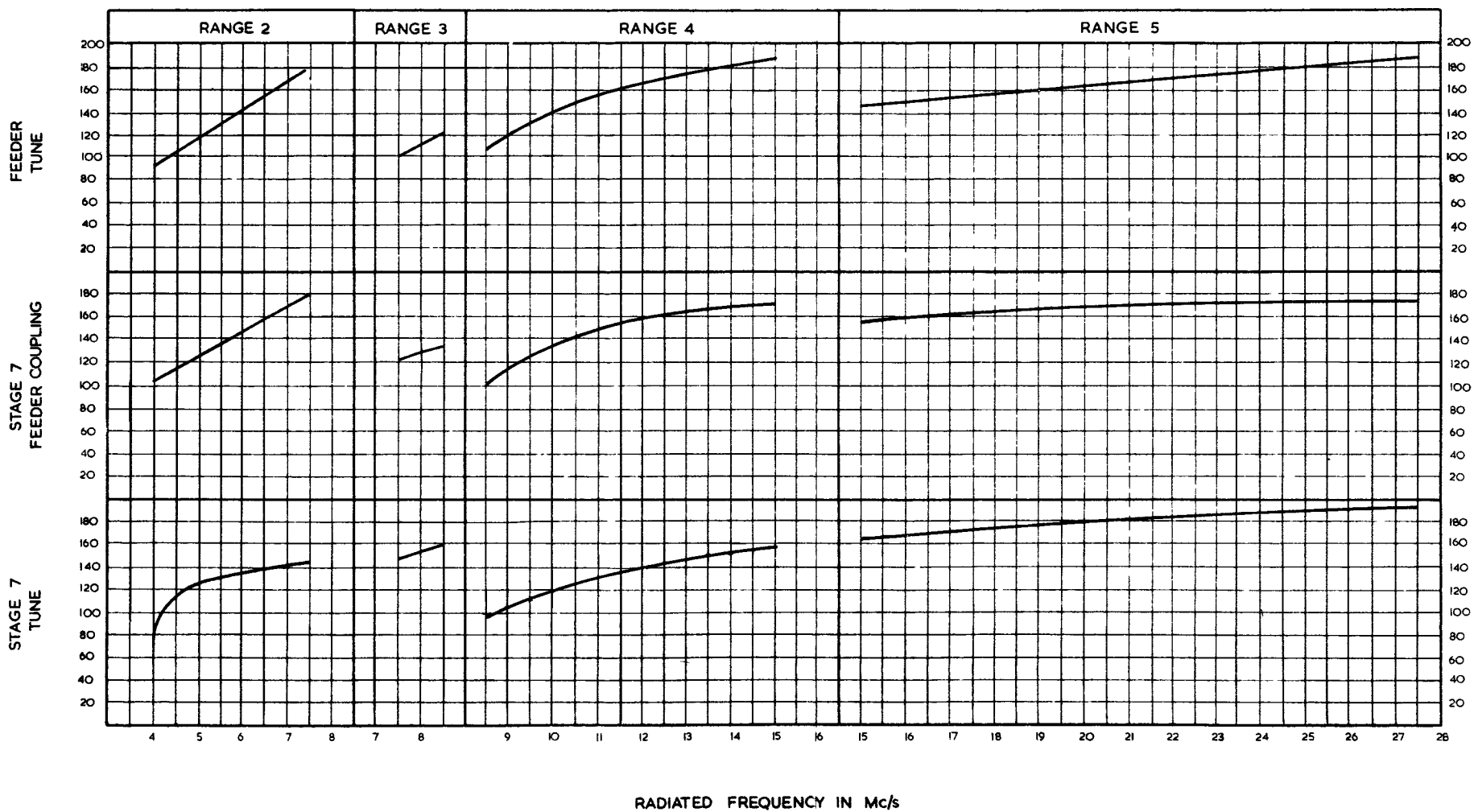
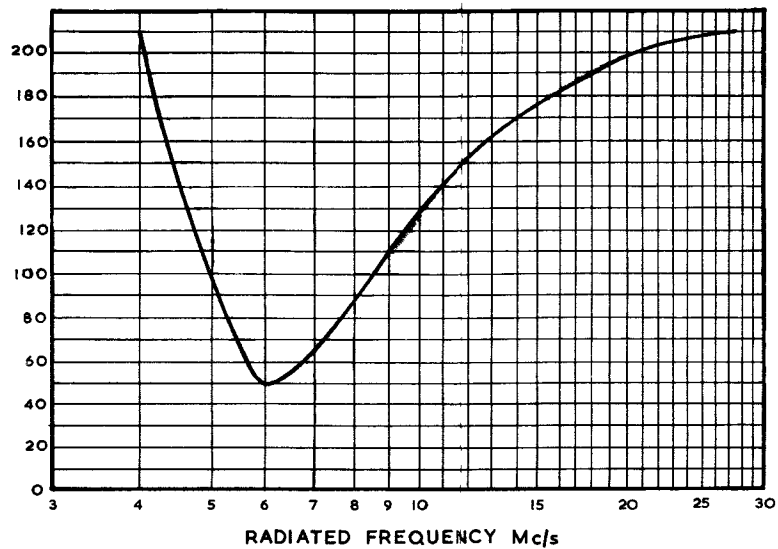

RADIATED FREQUENCY IN Mc/s
CALIBRATION CURVES, PART 3
TRANSMITTER TYPE HS71
WZ.18079/D Sh.3 Iss.1

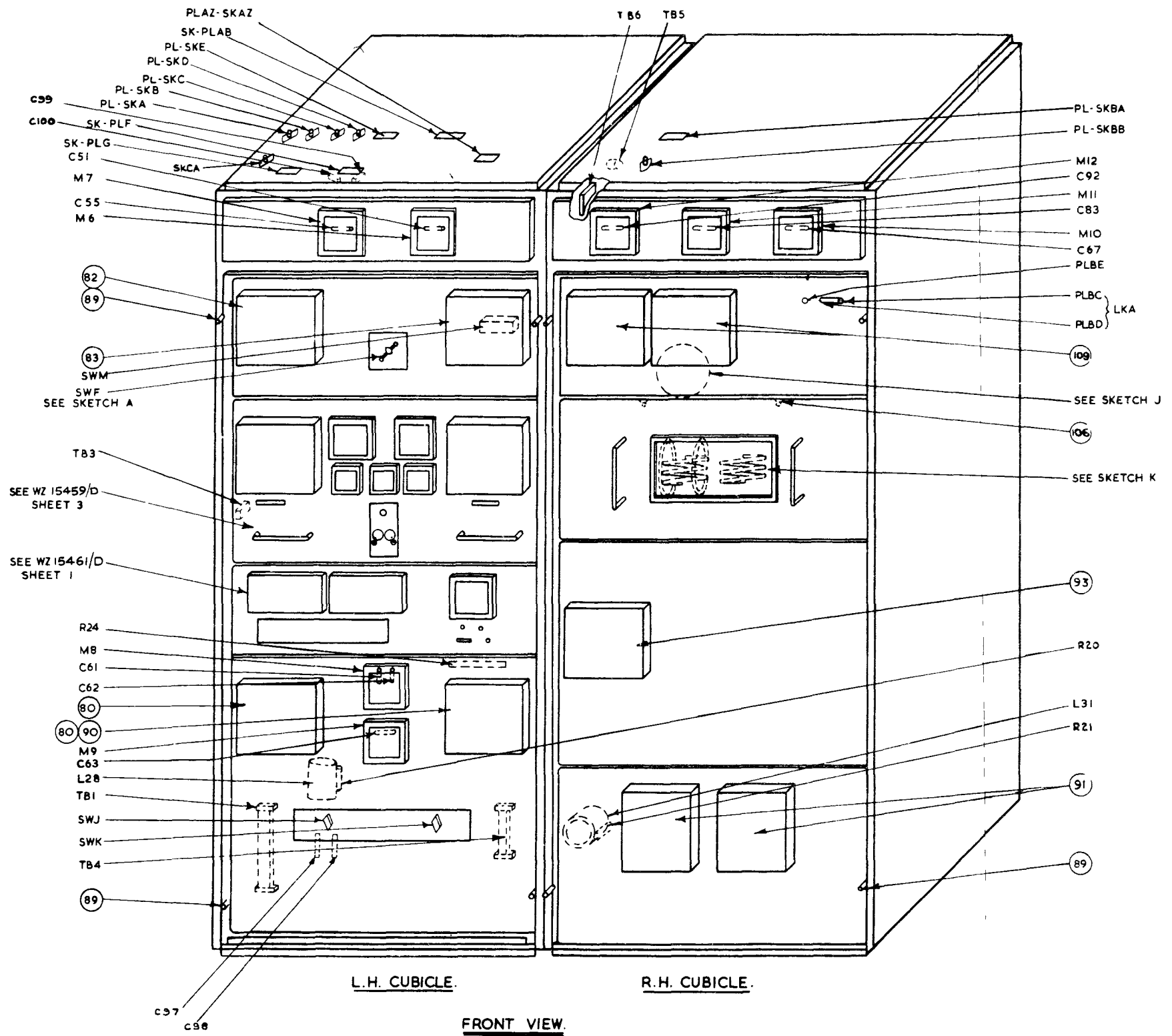

L.H. CUBICLE. R.H. CUBICLE.

FRONT VIEW.

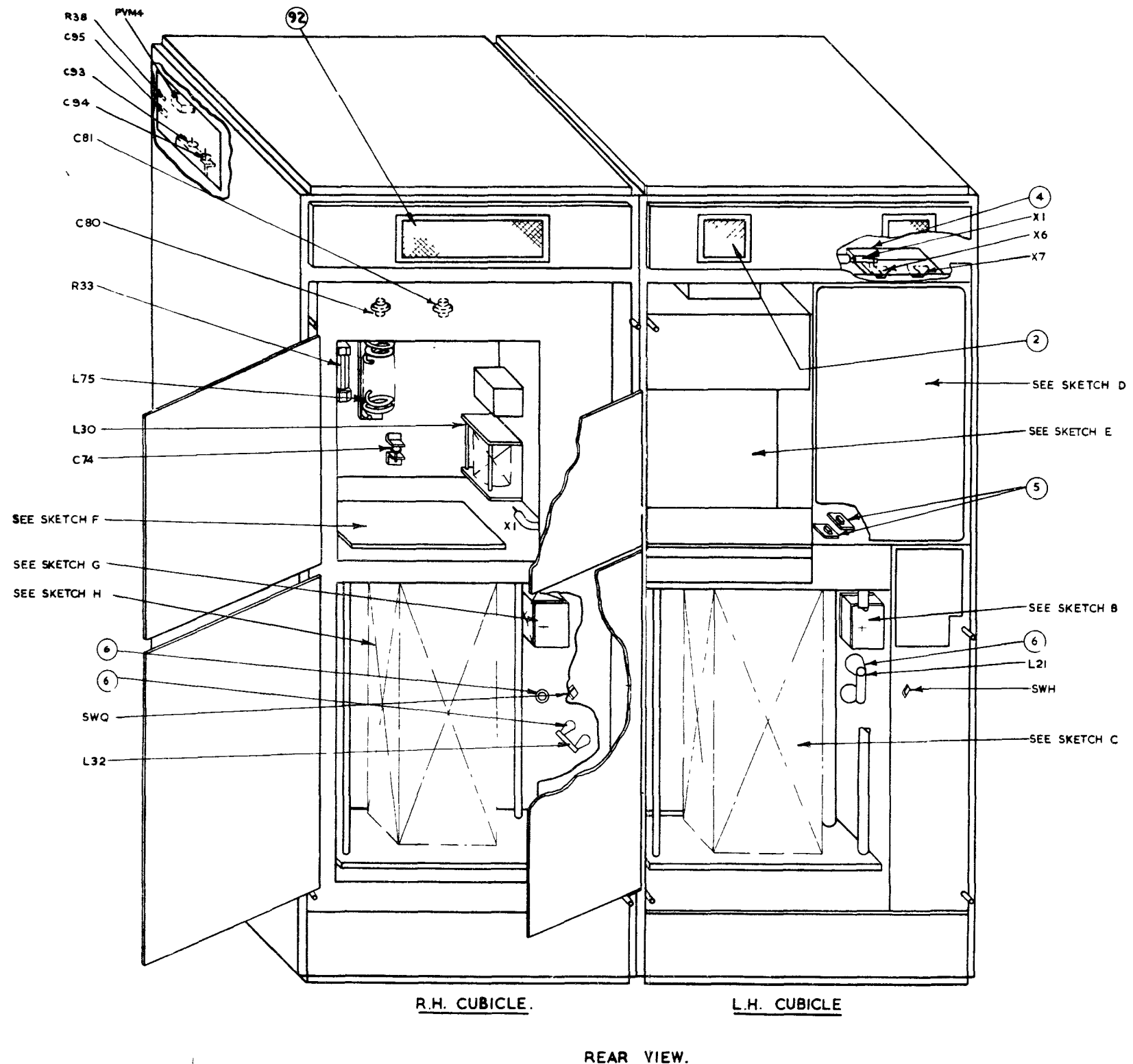

R.H. CUBICLE. L.H. CUBICLE.

REAR VIEW.

RF UNIT, COMPONENT LAYOUT, PART 1
WZ. 18082/D Sh. 1 Iss. 3

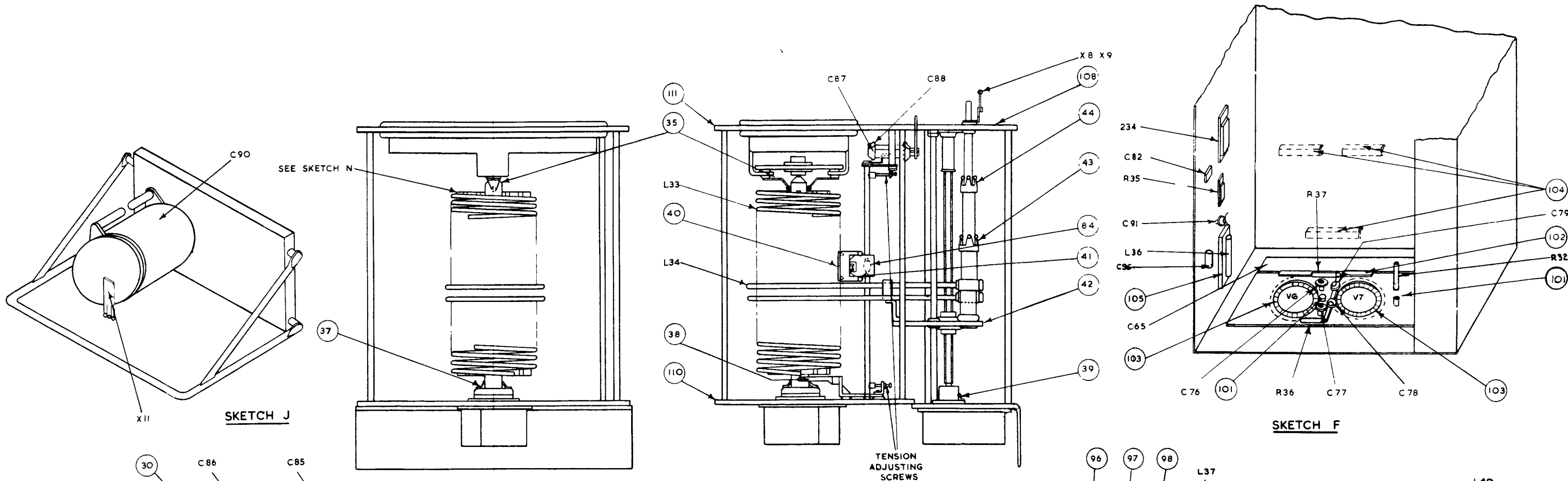

SKETCH J

SKETCH F

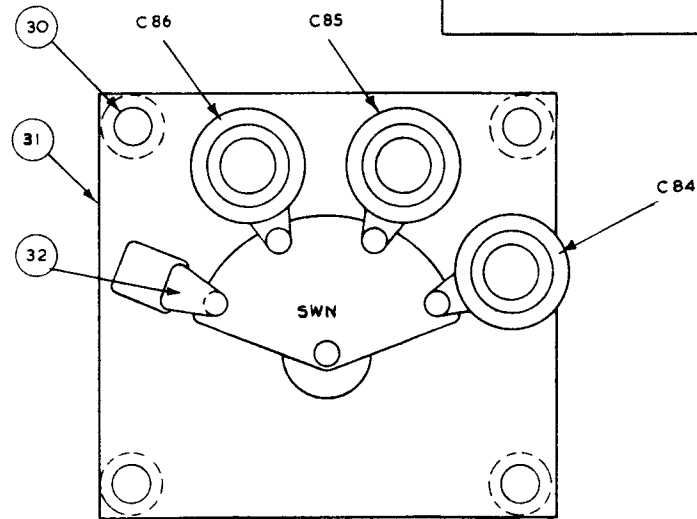

SKETCH G.

SKETCH H.

A VIEW LOOKING ON TOP OF THE ANODE COIL ASSEMBLY SHOWING POSITIONS OF MYCALEX COIL SUPPORTS RELATIVE TO CONNECTING CLAMP

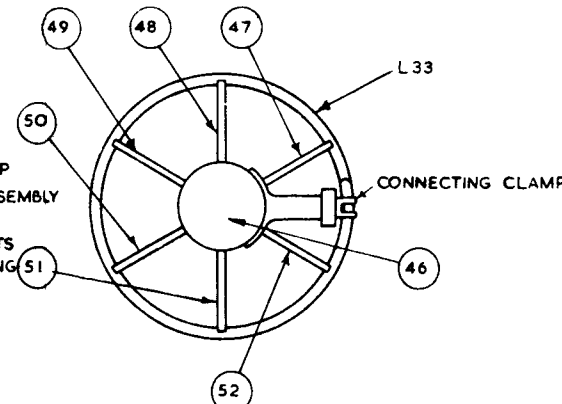

SKETCH N

TENSION ADJUSTING SCREWS

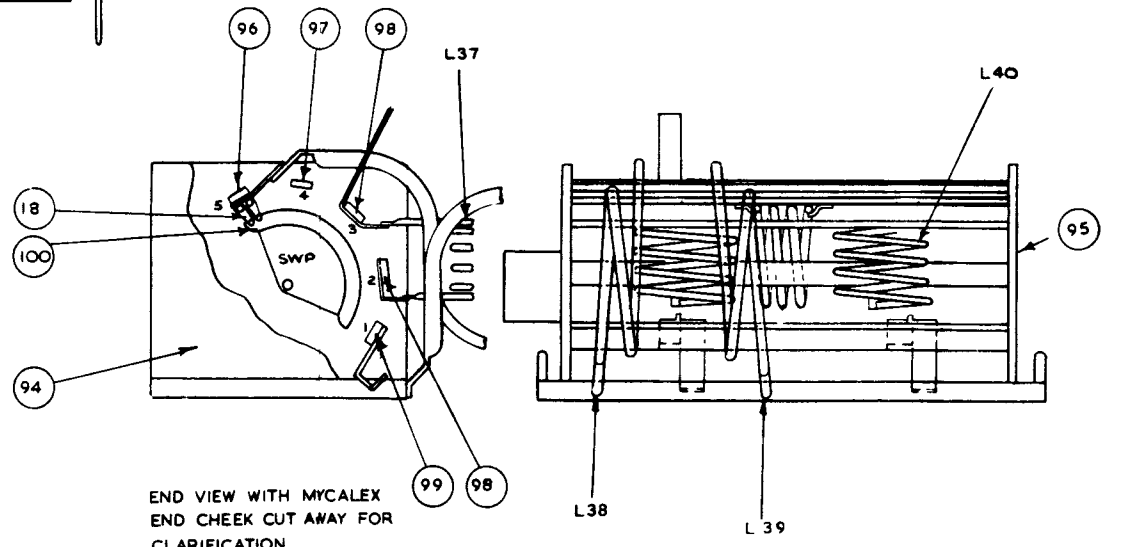

END VIEW WITH MYCALEX END CHEEK CUT AWAY FOR CLARIFICATION

SKETCH K

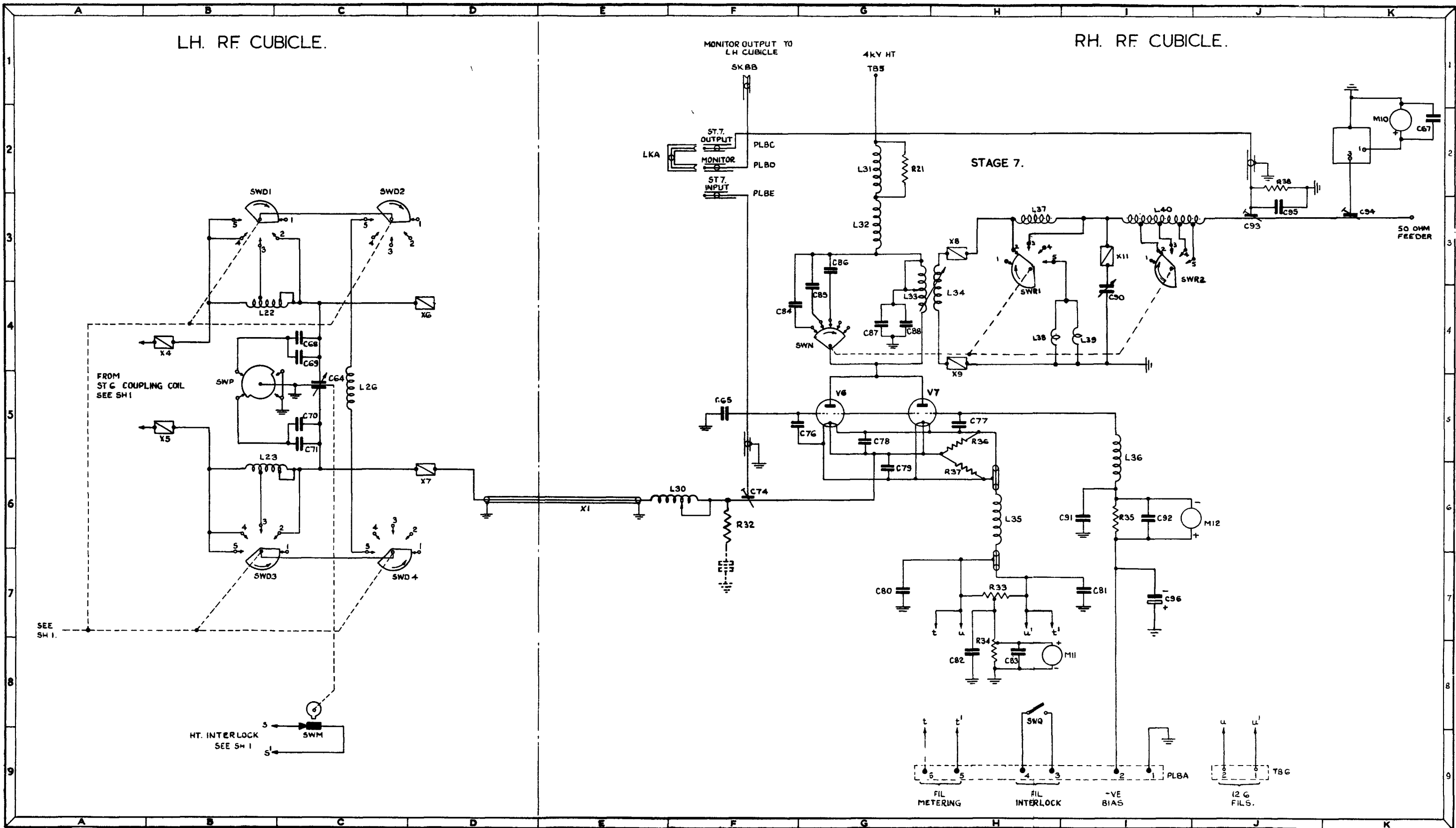

CIRCUIT DIAGRAM
 RADIO FREQUENCY UNIT
 WZ.18081/D Sh.2 Iss.4

9 kW HF ISB TRANSMITTERS
Types HS71 and HS71A

A. P. 2922E, Vol. 1, Edn. 2

Supplement 2

| AL

©

THE MARCONI COMPANY LIMITED,
CHELMSFORD.
Printed in Great Britain.

1964

CONTENTS

		Page
1	INTRODUCTION	1
2	EQUIPMENT LIST	1
	2.1 Coupler Assembly	1
	2.2 Portable Reflectometer Panel (Type S1/1 Ref.No.6625-99-993-1343)	1
	2.3 Indicator Panel Assembly	1
	2.4 Remote Metering Equipment	2
3	DESCRIPTION	2
	3.1 General	2
	3.2 Coupler Assembly Type 2865P	3
	3.2.1 Mechanical	3
	3.2.2 Electrical	4
	3.3 Indicator Panel Assembly	5
	3.3.1 Mechanical	5
	3.3.2 Electrical	5
	3.4 Portable Reflectometer Unit	6
	3.4.1 Mechanical	6
	3.4.2 Electrical	6
	3.5 Remote Reflectometer Panel	7
4	SETTING UP	7
	4.1 General	7
	4.2 Trip Levels	7
5	MAINTENANCE	8
	5.1 Coupler Units	8
	5.2 Portable Reflectometer Panel	8
	5.3 Indicator Panel Assembly	8

List of Illustrations

	Drg. No.	Fig. No
Coupler Assembly Type 2865P (Special) Circuit Diagram and Component Layout	HK/SK/52 Sh.3	1
Indicator Panel Assembly Circuit Diagram and Component Layout	WZ.31015/B Sh.1	2
Portable Reflectometer Panel Circuit Diagram and Component Layout	WZ.16129/B Sh.2	3
Feeder Monitoring Equipment Block Diagram	WZ.30872 Sh.1	4
Remote Metering Equipment Simplified Circuit	WZ.30871 Sh.1	5
Reflectometer Inter-connections	WZ.31160/B Sh.1	6

List of Component Lists

	List No
Coupler Assembly	1
Indicator Panel	2
Portable Reflectometer	3

Feeder Monitoring Equipment

for

HS.71

1 INTRODUCTION

The feeder monitoring system described herein provides visual indication of transmitted power and standing wave ratio (s.w.r.) in output feeder systems and is intended for use with a transmitter type HS.71, fitted with coaxial output feeders of 50 ohms characteristic impedance.

Forward and reflected waves in the feeder are sampled by directional couplers inserted at a convenient point near the feeder outlet on the transmitter roof and the coupler outputs are connected to a P.O. jack socket for use with a portable plug-in reflectometer panel. The coupler outputs can also be switched to provide duplicate readings at a common meter panel located in a central position.

In the event of the s.w.r. in any output feeder exceeding a predetermined level, the h.t. of the transmitter concerned is tripped, trip lamp LP5 is lit and the alarm bell X1 energized. The h.t. cannot be reinstated until the cause of the abnormal level is removed.

2 EQUIPMENT LIST

2.1 Coupler Assembly

	Feeder Type	Type No.	Drg. No.
HS.71	2 in Rigid	2865P	W.53928 Sh.6 Ed.P

2.2 Portable Reflectometer Panel (Type S1/1 Ref.No.6625-99-993-1343)

Type No.	Drg. No.
2959G	W.55604 Sh.1 Ed.G

2.3 Indicator Panel Assembly

Type No.	Drg. No.
4768A	W.68874 Sh.1 Ed.A

2.4 Remote Metering Equipment

Drg. No.

Meter, Power	WIS.9288/B Sh.1 Ref.1
Meter, SWR	WIS.4235 Sh.16 Ref.253
Relays, K.3000 2C, $\pm 10\%$, 100V	PC.64901/12

3 DESCRIPTION

3.1 General

The forward and reflected waves on the aerial feeders are sampled at convenient points by directional couplers. Each coupler consists of a small coil supported in the space between the inner and outer conductor of a rigid coaxial feeder. One end of the coil is earthed via a resistive load and the other is brought out via an insulated bush to the external circuits. The coil is coupled both inductively and capacitively to the transmission line and the mutual inductance between the line and the coil can be varied both in magnitude and sign by rotation of the coil but the capacity is not altered to the same extent. This makes it possible to adjust the coil so that the inductive and capacitive pick-up voltages cancel, and there is no output from a wave travelling in one direction in the transmission line. For a wave in the opposite direction in which the phase relationship is reversed, the inductive and capacitive voltages will be additive and there will be a voltage output. Two couplers therefore are employed, one set to respond to the forward wave and the other to the reflected wave. The two couplers are arranged close together in a short length of transmission line, referred to as a coupler assembly, and their outputs are fed to circuits mounted on a platform forming part of the assembly, and enclosed by a metal cover. For brevity the directional coupler responding to the forward wave and that to the reflected wave are referred to as forward and backward couplers respectively, and their outputs are called forward and backward signals, the last designations bearing no relation to the direction of flow of these outputs in subsequent rectifying and indicating circuits.

The outputs from both couplers after passing through equalising networks which provide frequency compensation, are then rectified. The resulting currents are then fed via output terminals TBl(1) and TBl(3) to the Indicator Panel Assembly which is mounted on the transmitter front near the feeder outlet. Inside the unit the backward line current is connected to one pole (SWA1) of a TEST TRIP key switch SWA, the forward line current is similarly connected to another pole SWA2. Pole SWA3 is connected to a d.c. supply for testing and setting the h.t. trip circuit. With switch SWA in the normal position, both forward and backward line currents are fed back to the coupler via terminals TBl(4)

and TB1(2) respectively, where they pass through variable resistors providing a fine sensitivity control and then through the coils of a sensitive dual wound trip relay. The latter is thereby operated at a predetermined current difference, giving a trip level reasonably independent of power. The relay contacts RL1 in the Coupler Unit, when closed, cause relay RLA in the Indicator Panel to operate.

The monitoring circuit is terminated on the frame of the coupler unit via the frame and two auxiliary contacts on a P.O. type jack. Inserting the plug attached to a portable reflectometer panel breaks the two auxiliary contacts and the circuit to earth is then completed via the portable unit and the plug sleeve.

Remote indication of transmitted power and s.w.r. is provided by a metering panel mounted in the Test Equipment Rack. A two pair cable is fed from each transmitter monitoring point to the banks of a uni-selector contained in the Power and Frequency Monitor Rack. When a transmitter is selected by a key switch on the control desk the lines from the selected transmitter are connected via the uniselector to the power and s.w.r. meters located in the Test Equipment Rack.

In order to maintain the local metering and trip levels independent of the remote meters when they are switched out of circuit, an equivalent resistance is inserted in each line by means of a relay fitted with two sets of changeover contacts. One relay is provided for each transmitter to be monitored.

To cater for the different power output levels of the types of transmitter to be monitored a special triple scale power meter is used on both the portable and remote metering panels.

3.2 Coupler Assembly

3.2.1 Mechanical

The unit consists of a short cylindrical aluminium casting machined internally and fitted with a concentric inner terminated in the appropriate coaxial connectors. The casting is extended to form a platform through which two directional couplers are let into holed in the platform and project into the space between inner and outer conductors. Depth of penetration is determined by a collar held by grub screws: after setting to the correct depth and rotating to the correct position the two couplers are locked in position by grub screws in bosses on the casting. On no account should their position be altered. Three potentiometers are supported by a bracket at one side: their spindles are locked and RV2 and RV3 which affect the meter calibration should not be disturbed. A P.O. type jack is mounted at one end of the platform and a dual wound trip relay at the other. Connections are made to a

terminal block and are taken out through a hole in the platform. A rectangular cover fits over the assembly and is held in position by a single screw at the front. A hole is provided in the cover to enable the portable meter unit to be plugged into the P.O. type jack. Each end of the cylindrical casting is split and provided with a nut and bolt for clamping in position on the feeder.

NOTE: The arrow on the coupler body must agree with the direction of transmission.

3.2.2 Electrical

Circuit Diagram Fig.1

In the coupler unit the forward signal is picked up by coil X2 and rectified by the germanium crystal rectifier MR2 and smoothed by the resistance-capacity network R4, C5 and C6. An identical coil X1 picks up the backward signal which is rectified and doubled by MR1, MR4, C2, C8, the rectified output is smoothed by R3, C2 and C3. Both of the identical coils X1 and X2 have a rising frequency output characteristic and to compensate for this the filters C1, R1 and C4, R2 have been inserted to give a substantially flat response. The components MR3, C7 and R5 are also compensating elements to counteract the effect of non-linear rectification at low levels.

The rectified outputs of X1 and X2 representing the backward and forward line voltages respectively, are taken to the output terminals TB1(1) and TB1(3) respectively and thence to terminals TB2(1) and TB2(3) on the Indicator Panel Assembly. Inside this unit the backward line voltage (TB2(1)) is connected to a pole of the TEST TRIP switch SWA1 and then via the moving contact to terminal TB2(4). The forward line voltage (TB2(3)) is connected to another pole SWA2 and then via the moving contact to terminal TB2(2). Both TB2(4) and TB2(2) are connected back to the coupler assembly via terminals TB1(4) and TB1(2) respectively. These terminals are connected to variable resistors RV3 and RV2 which are the fine sensitivity controls for the backward and forward currents. Coarse control is afforded by the penetration of the couplers as previously described. RV3 and RV2 are connected to a dual wound moving coil trip relay RLA. The polarities of the coils are such that the currents work in opposition, the backward current seeking to close contact RL1 and thereby furnish a trip, and the forward current tending to hold this contact open. The forward coil of RLA is shunted by a variable resistor RV1 which is used to set the trip level at which the relay will operate. The backward and forward lines from the relay coils are terminated to earth via the auxiliary contacts of jack JKA and the remote meters or via the jack ring when the portable meter is plugged in.

3.3 Indicator Panel Assembly

Circuit Diagram Fig.2

3.3.1 Mechanical

The unit consists of a chassis on which various components are mounted and a rectangular metal cover secured by four screws. The unit is fixed in position by four screws through the rear panel. An indicator lamp and key switch project through the front face of the cover and two holes are provided for adjusting two preset potentiometers mounted on the chassis. The two position key switch is non-locking in the test position.

3.3.2 Electrical

The Indicator Panel has the following functions:-

- (a) To lock out the transmitter on a fault condition and to indicate that tripping has occurred.
- (b) To generate and apply test signals for checking the trip operation.

When the s.w.r. on the lines rises above the predetermined limit, RLA in the Coupler Unit operates and contact RLAL in the Coupler Unit opens, enabling relay RLA in the Indicator Panel to operate. (MRL acts as a spark quench device.) Contact RLAL in the Indicator Panel opens when RLA (Indicator Panel) operates, enabling SP to operate. Contact SP1 closes, energizing relay OR which, once energized, is held operative by its own contact OR3 until the trip reset button SWF is operated. Contact OR5 energizes the alarm bell X1 and contacts OR1 and OR2 release, de-energizing relay MC which trips the l.t. supply. This results in the release of trip relay RLA in the Coupler Unit, causing contact RLAL (Coupler Unit) to open. This contact is covered by RLA2 (Indicator Panel) which ensures that relay RLA (Indicator Panel) remains operated. Contact RLA3 (Indicator Panel) operates fault lamp LP1.

A 6.3V a.c. supply, derived from the transmitter, enters the unit via terminals TB2(10) and (11), is rectified by MR2, smoothed by C1 and connected to potentiometers RV1 and RV2, the circuit being completed through one pole of the TEST TRIP switch SWA when switched to the test position. The potentiometers RV1 and RV2 are adjusted to simulate the d.c. voltages obtained from couplers X1 and X2 and are used to check visually the response of the trip circuit in the Coupler Unit. The TEST TRIP switch normally passes signals from X1 and X2 to the monitoring circuits via poles SWA1 and SWA2. Potentiometer RV1 and RV2 can be adjusted with a screwdriver through the two holes provided in the front panel, and in conjunction with the portable meter unit, the response of the trip circuit over the power range may be observed.

A.P.116E-0232-1
A.L.9, Feb.1971
Supp.2

3.4 Portable Reflectometer Unit

3.4.1 Mechanical

The portable reflectometer unit is built into a small metal box with a sloping front. It can be stood on a convenient support or may be hung on the feeder near a coupler assembly, two hooks at the back being provided for this purpose. A carrying handle is also fitted.

On the front panel are two large square faced meters, one calibrated to read power and the other to read standing wave ratio. The power meter is provided with a triple scale to cater for the different power outputs of the transmitters on the station. The scale ranges are as follows:-

Scale	Transmitter	Range KW
Top	HS.51	0-42
Middle	HS.71	0-14
Bottom	HS.31	0-4.2

The power output from each type of transmitter is read directly on the scale without switching at the panel, the outputs from the various couplers being adjusted by the maker to suit the type of transmitter to which they are to be fitted.

All components are mounted behind the front panel and the cable which is connected to the coupler assemblies by means of a jack plug, leaves the instrument through a bushed hole in the side.

3.4.2 Electrical

Circuit Diagram Fig.3

The forward signal is applied firstly to a power indicator M1 the scale being calibrated to read outgoing power in the feeder. The scale used is determined by the response of the directional coupler circuits. The signal is then passed to the control coil of ratiometer M2 and then to earth via the case of the unit and the sleeve of plug PL. The backward signal is applied to the deflection coil of M2 and then to earth. The meter M2 indicates the ratio between the current flowing in the control coil to the current flowing in the deflector coil. The movement has no restoring spring, but any current (above a certain minimum) in the control coil will bring that coil into a neutral plane and the pointer to the zero mark. Deflection is then caused by current in the deflection coil and, by virtue of the specially shaped permanent magnet pole pieces, the deflection bears the required relationship to the current ratio. Full scale deflection is given when control and deflection currents are equal. The values of the components in the coupler circuits

are so chosen that equal currents are produced when the s.w.r. in the feeder is infinite, the ratiometer scale is therefore calibrated 1 to infinity. All meter coils are bypassed by fairly large value mica capacitors C1, C2 and C3 to prevent erroneous readings due to stray r.f. fields.

3.5 Remote Reflectometer Panel

Circuit Diagram Fig.5.

This comprises a panel on which are mounted two meters, one reading power and the other, s.w.r. The Power meter is identical with that fitted on the Portable Reflectometer Unit but there is an extra scale added to the s.w.r. meter to read 'Power Factor'. This gives the ratio of transmitted power to the power indicated on the power meter.

To find the power transmitted to the load the power meter reading must be multiplied by the P.F. reading since the power meter indicates the power of the forward wave, a proportion of which is reflected at the load terminals.

The power and s.w.r. for any transmitter on the station will be indicated on this panel after selecting the desired transmitter by switching at the control desk. All lines not connected through to the meter panel via the uniselector are terminated with equivalent resistances switched into circuit by relays. One relay with two sets of changeover contacts is required for each transmitter to be monitored.

4 SETTING UP

4.1 General

The Coupler Assemblies and Indicator Panels are permanently connected in the feeders at points where monitoring facilities are required. The portable reflectometer panel is intended to be carried around from one coupler to another as required. Duplicate readings are given at the remote metering panel by switching at the control desk.

4.2 Trip levels

Proceed as follows:

- (a) Switch on the filament and control supplies of the transmitter
- (b) Set the POWER LEVEL and S.W.R. LEVEL controls RV1 and RV2 respectively, on the Indicator Panel Assembly to minimum output.
- (c) Plug the portable reflectometer panel into the jack located in the Coupler Unit.
- (d) Depress the TEST TRIP switch SWA in the Indicator Unit.

- (e) Adjust the POWER LEVEL control until the reading on the portable meter corresponds with a reading of 10 kW.
- (f) Increase S.W.R. LEVEL control slowly until the fault lamp on the Indicator Panel and the alarm bell X1 operate, indicating a trip, then turn control back to minimum.
- (g) On the Rectifier and Control Unit press the H.T. OFF and RESET button: the indicator lamp should be extinguished and the audible alarm should cease.
- (h) Undo the locking device on potentiometer RV1 in the Coupler Unit and by successively increasing the S.W.R. LEVEL, adjusting RV1 and resetting the trip after each trial, continue until the trip occurs with a s.w.r. of 2 shown on the meter. Release the TEST TRIP switch and lock RV1 at this setting.

5 MAINTENANCE

5.1 Coupler Units

The settings of the directional couplers, other than that of RV1, should in no circumstances be altered. They are locked in position, and cannot be reset without special equipment and should be returned to The Marconi Company Limited for recalibration if they are disturbed or damaged.

NOTE...Owing to very stringent testing and setting-up requirements couplers can NOT be supplied as 'off the shelf' replacements. It is essential, therefore, that orders for replacement couplers be endorsed:
'To be tested to Marconi Specification before issue'.

5.2 Portable Reflectometer Panel

The panel should require little attention other than replacement of the Cable Connections if these become worn from use.

5.3 Indicator Panel Assembly

This unit should require no attention apart from the replacement of an indicator lamp in the event of a failure.

COMPONENT LIST NO.1

FOR

COUPLER UNIT TYPE 2865P (Modified)

(Drg. No. HK/SK Sh.3)

- NOTES: 1. When ordering spares quote identity only.
2. References in column 1 are normally shown on the circuit and component location diagram Fig. 1.
3. For identical items the total quantity is given at the first entry.

Ref.	Description	Value	Tol. %	Rating	Identity	Qty.
	<u>CAPACITORS</u>					
C1	Mica Metallised Insulated	390p	±2	350V	PC.18803/39	2
C2	Ceramic, Post Type	.001 µF	±20	500V	WIS.4832/C/2/13	5
C3	Ceramic, Post Type	.001 µF	±20	500V	WIS.4832/C/2/13	
C4	Mica Metallised Insulated	390p	±2	350V	PC.18803/39	
C5	Ceramic, Post Type	.001 µF	±20	500V	WIS.4832/C/2/13	
C6	Ceramic, Post Type	.001 µF	±20	500V	WIS.4832/C/2/13	
C7	Ceramic, Post Type	.001 µF	±20	500V	WIS.4832/C/2/13	
C8	Mica Metallised Insulated	470 pF	±2	350V	PC.18803/41	1
	<u>RESISTORS FIXED</u>					
R1	Comp. Grade 1	15Ω	±5	¼W	PC.66604/4	2
R2	Comp. Grade 1	15Ω	±5	¼W	PC.66604/4	
R3	Comp. Grade 1	330Ω	±5	¼W	PC.66604/19	2
R4	Comp. Grade 1	330Ω	±5	¼W	PC.66604/19	
R5	Comp. Grade 1	1.5 kΩ	±5	¼W	PC.66602/22	1
R6	Comp. Grade 1	2.2 kΩ	±5	¼W	PC.66602/24	2
R7	Comp. Grade 1	2.2 kΩ	±5	¼W	PC.66602/24	

COMPONENT LIST NO.1 (Contd.)

Ref.	Description	Value	Tol. %	Rating	Identity	Qty.
	<u>RESISTORS VARIABLE</u>					
RV1	Wirewound Linear	500Ω	±10	½W	PC.67401/17	1
RV2	Wirewound Linear	5 kΩ	±10	½W	PC.67401/29	2
RV3	Wirewound Linear	5 kΩ	±10	½W	PC.67401/29	
	<u>MISCELLANEOUS ELECTRICAL ITEMS</u>					
JKA	8 Point Jack				W1S.3150/C/1/1	1
MR1	Crystal Rectifier CG64-H					4
MR2	Crystal Rectifier CG64-H					
MR3	Crystal Rectifier CG64-H					
MR4	Crystal Rectifier CG64-H					
RLA	Relay				W1S.6831/B/1/2	1
TB1	Terminal Block 9 Way				W.21919/C/1/1	1
X1	Reflectometer Assy.				W.69200/1/A	2
X2	Reflectometer Assy.				W.69200/1/A	

COMPONENT LIST NO.2
FOR
INDICATOR PANEL TYPE 4768A
(Drg. No. W.68874 Sh.1 Ed.A)

- NOTES: 1. When ordering spares quote identity only.
2. References in column 1 are normally shown on the circuit and component location diagram Fig. 2.
3. For identical items the total quantity is given at the first entry.

Ref.	Description	Value	Tol. %	Rating	Identity	Qty.
	<u>CAPACITORS</u>					
C1	Electrolytic	50 μ F	+100 -20	12V Peak Working	PC.18402/16	
	<u>RESISTORS (FIXED)</u>					
R2	Composite Grade 2 Insulated	560 Ω	\pm 10	$\frac{3}{4}$ W	PC.66612/16	1
R3	Composite Grade 2 Insulated	8.2 k Ω	\pm 10	$\frac{3}{4}$ W	PC.66612/30	1
R4	Composite Grade 2 Insulated	470K	\pm 10	$\frac{1}{4}$ W	PC.66610/57	1
	<u>RESISTORS (VARIABLE)</u>					
RV1	Wirewound Linear	5 k Ω	\pm 10	$\frac{1}{2}$ W	PC.67401/29	2
RV2	Wirewound Linear	5 k Ω	\pm 10	$\frac{1}{2}$ W	PC.67401/29	
	<u>MISCELLANEOUS ELECTRICAL ITEMS</u>					
LP1	Lamp E10 Clear 6.5V 2.3W				PC.48701/2	1
MR1	Rectifier, Westing- house Type T5D/19					1
MR2	Rectifier CG64H					1
SWA	Switch Lever 2 Position				PC.71202/2	1
RLA	Relay 2B 2M				PC.65406/15	1
TR1	Terminal Block 12 Way				WIS.1631/1/12	1

Schedule compiled from
WZ.18970/A

COMPONENT LIST NO.3
FOR
PORTABLE REFLECTOMETER PANEL TYPE 2959G
(Drg. No. W.55604 Ed.G)

- NOTES: 1. When ordering spares quote identity only.
2. References in column 1 are normally shown on the circuit and component location diagram Fig.3.
3. For identical items the total quantity is given at the first entry.

Ref.	Description	Value	Tol. %	Rating	Identity	Qty.
<u>CAPACITORS</u>						
C1	Mica	.01 μ F	± 20	350V	PC.18701/5	3
C2	Mica	.01 μ F	± 20	350V	PC.18701/5	
C3	Mica	.01 μ F	± 20	350V	PC.18701/5	
<u>MISCELLANEOUS ELECTRICAL ITEMS</u>						
PLA	Plug G.P.O. Type 316				WIS.2499/1	1
TB1	Terminal Block				W.21523/C/1/M	1
M1	Power Indicator Meter				WIS.9288/B/1	1
M2	Ratiometer				WIS.4235/1/253	1

Schedule compiled from
WZ.16129/A

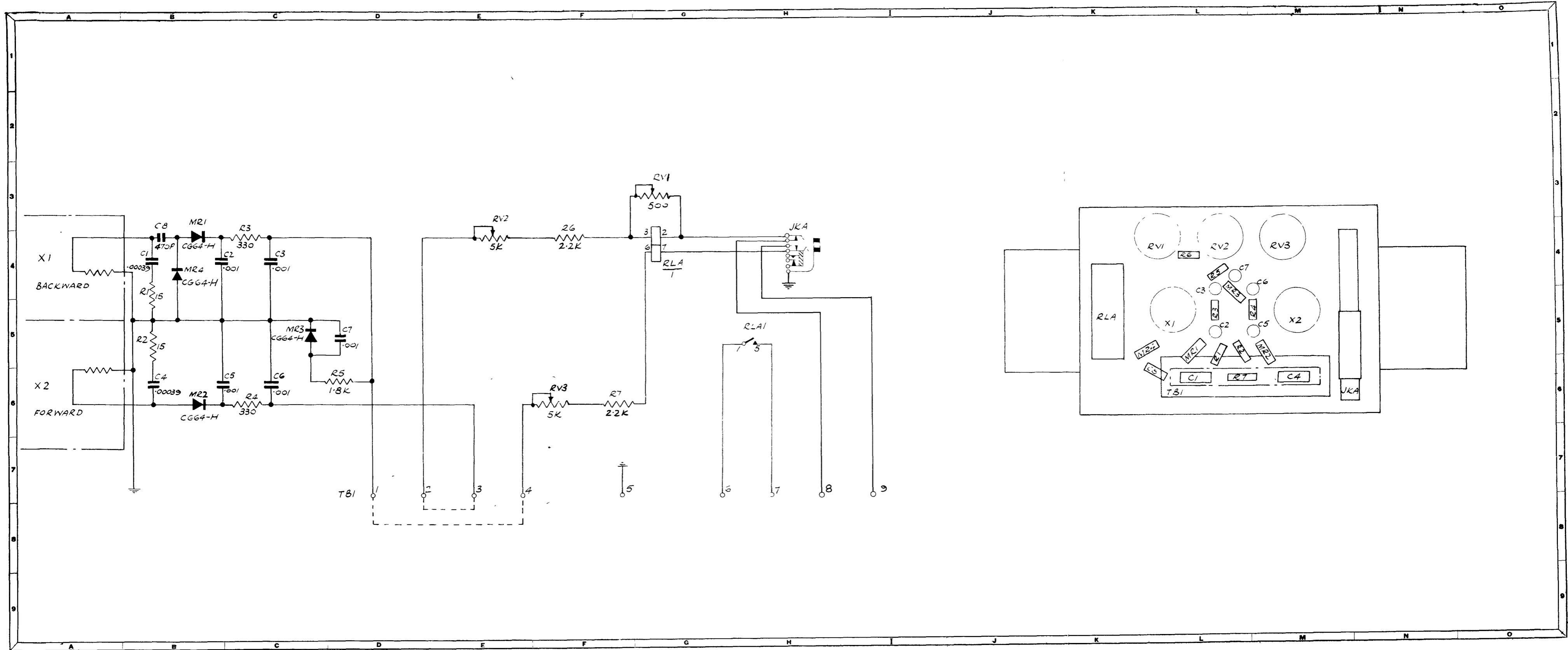

COUPLER ASSEMBLY TYPE 2865P (SPECIAL)
 CIRCUIT AND COMPONENT LAYOUT
 HK/SK/52 Sh.3 Iss.1

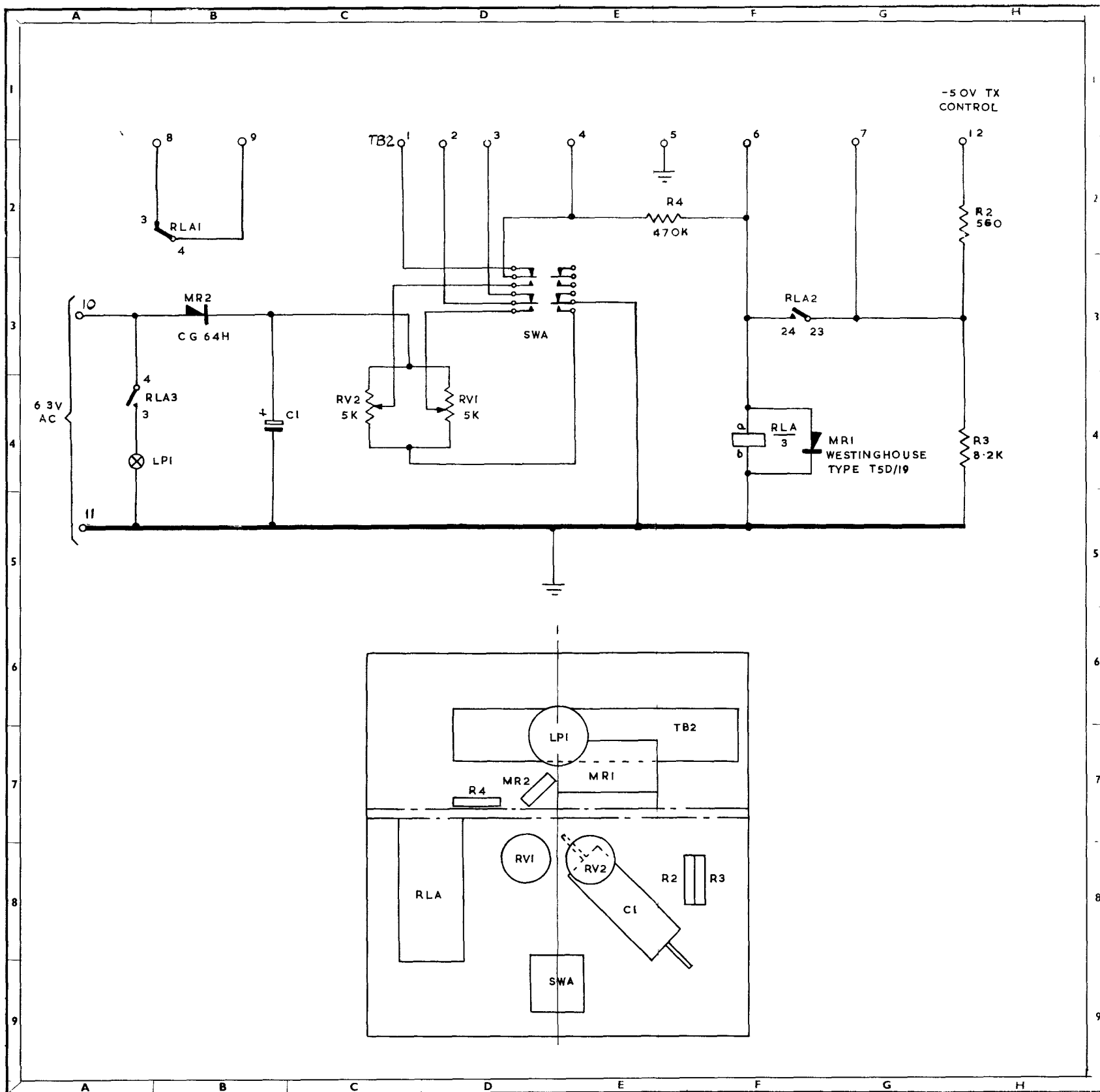

INDICATOR PANEL ASSEMBLY
 CIRCUIT AND COMPONENT LAYOUT
 WZ.31015/B Sh.1 Iss.3

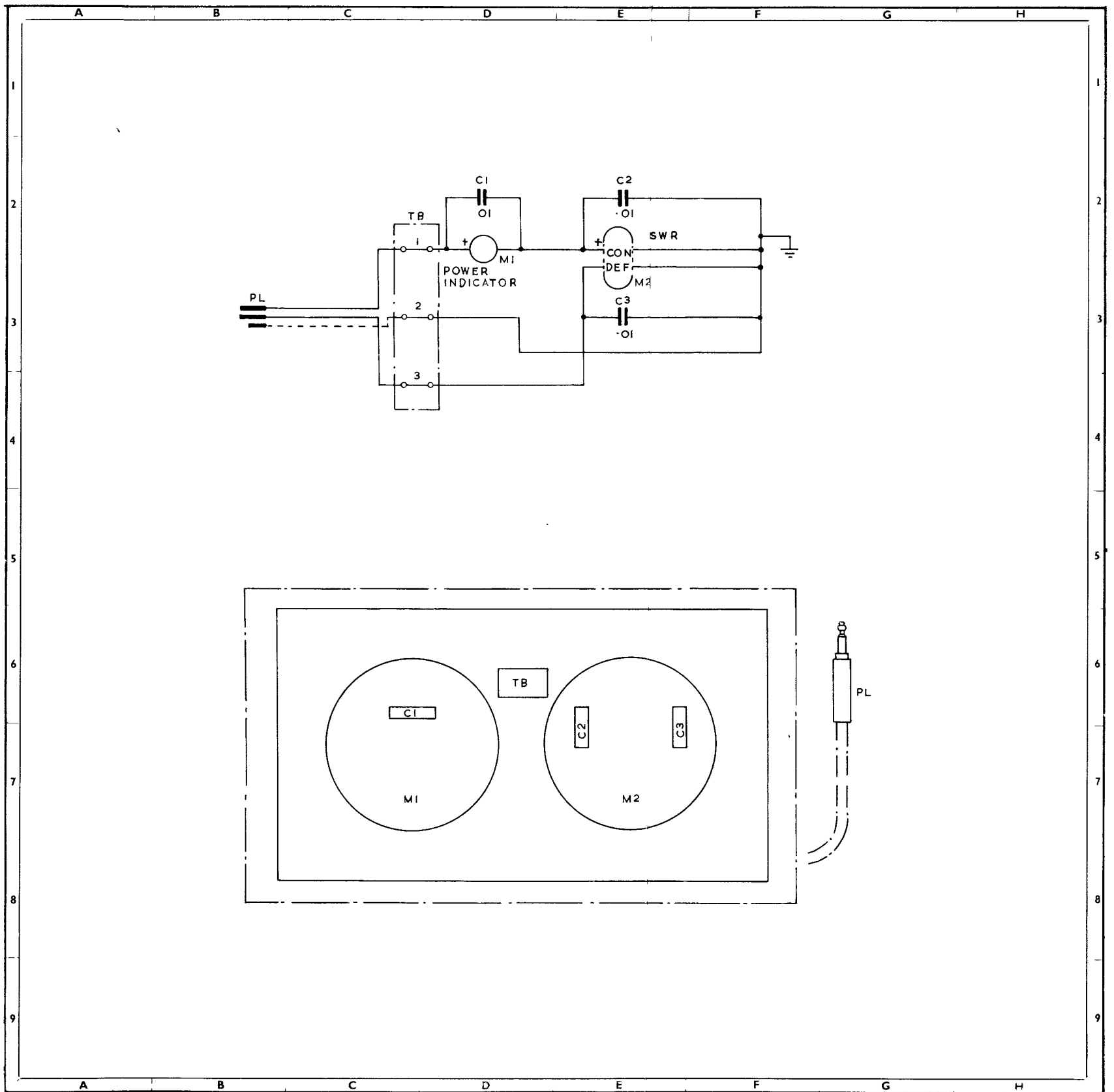

PORTABLE REFLECTOMETER PANEL
 CIRCUIT AND COMPONENT LAYOUT
 WZ.16129/B Sh.2 Iss.1

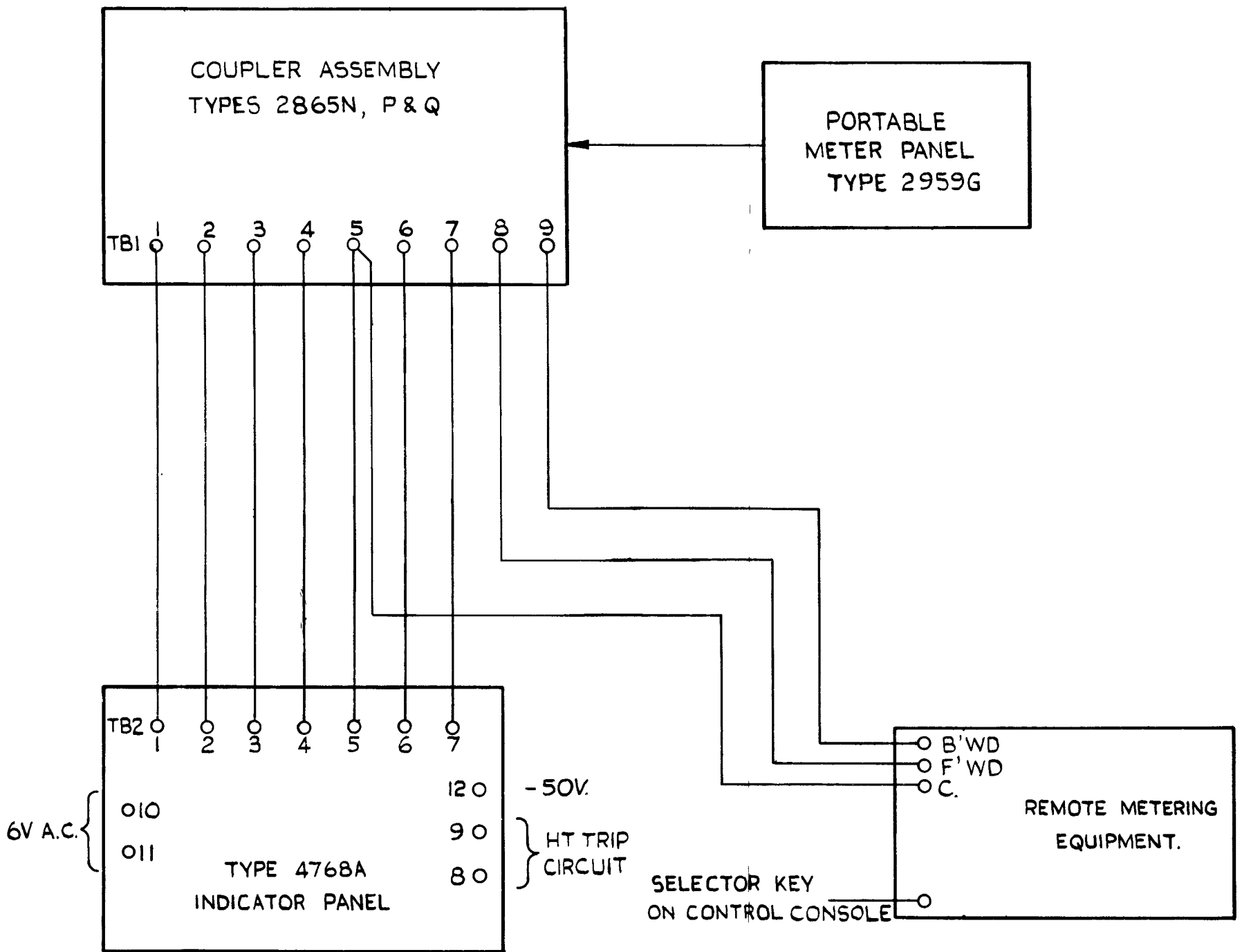

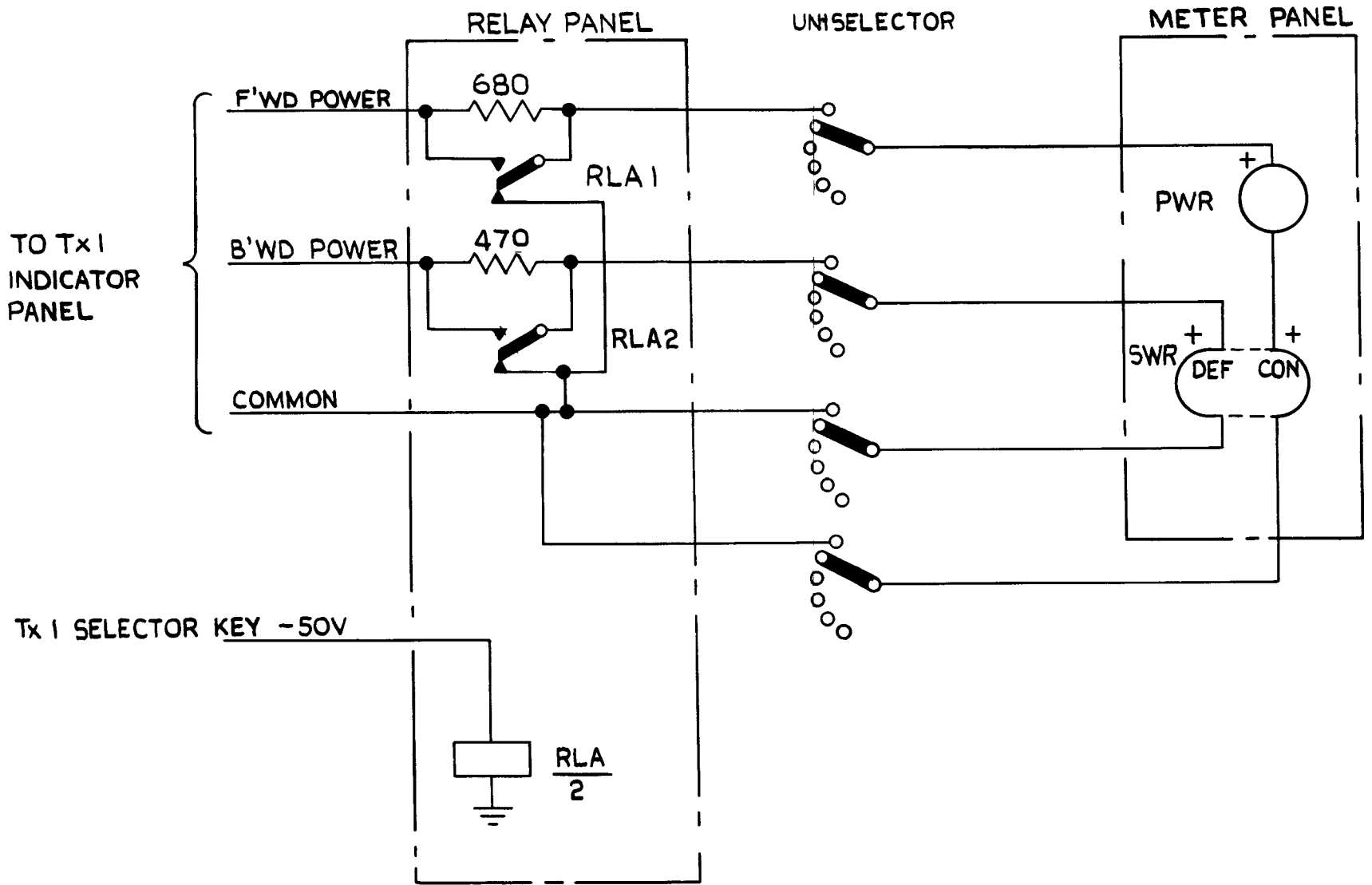

COUPLER UNIT CONNECTOR

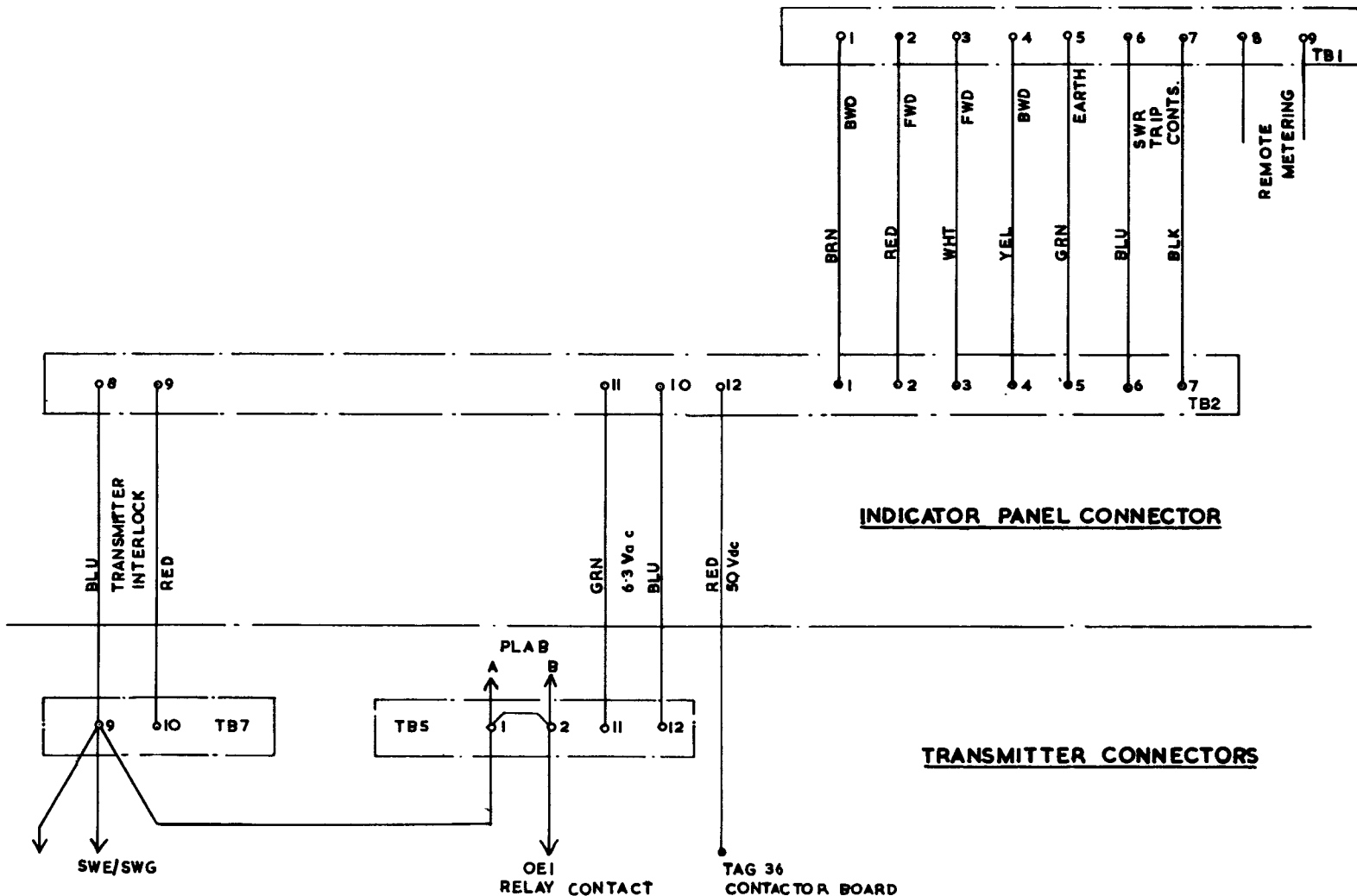

NOTE: THIS LEAD HAS BEEN REPOSITIONED

9 kW HF ISB TRANSMITTERS
Types HS71 and HS71A

A.P. 2922E, Vol. 1, Edn. 2

Supplement 3

©

THE MARCONI COMPANY LIMITED,
CHELMSFORD.
Printed in Great Britain.

19

CONTENTS

	Page
1 INTRODUCTION	1
2 TRANSMITTER DIFFERENCES	1
3 DESCRIPTION OF EQUIPMENT	2
3.1 General	2
3.2 Drive Level Control	2
3.3 Harmonic Generator	3
3.4 Stage 5	4
3.5 Stages 6 and 7	4
3.6 Monitoring	5
4 SETTING-UP THE DRIVE LEVEL CONTROLS	5
5 ALIGNMENT OF THE MIXER UNIT	6
6 HS.71 and HS.71A MODIFICATIONS	7
6.1 Balanced Mixer	7
6.2 Rectifier and Control Unit Fan	8
6.3 Air Filters	8
6.4 Time Switch, FD	8
6.5 H.T. Fuses FS7, 8 and 9	8
6.6 Indicator Lamps	8
6.7 Mixer Suppressor Bias	8

List of Tables

Table 1 List of Ancillary Units and Intermediate Frequencies	2
Table 2 Crystal Frequency Table	3
Table 3 Linked-in and Clipped-in Components	4
Table 4 Alignment Frequencies	6

9 kW HF ISB TRANSMITTERS

Types HS71 and HS71A

1 INTRODUCTION

The Types HS.71 and HS.71A are general purpose transmitters for use in the frequency range 2.5 to 27.5 Mc/s, HS.71A covering the band 2.5 to 20 Mc/s and the HS.71 4 to 27.5 Mc/s. The two transmitters are similar

Supplement 3, page 1, 2nd para., at end, amend to read 'the (am.) band 6 - 20 Mc/s'.

External units are used to provide the drive and the type of service required. Drive frequencies are normally supplied by Type HD.21 Crystal Drive Units. The type of service is supplied by various units at different intermediate frequencies depending on the service and type of transmitter. The i.f. may also be dependent on the required radiated frequency i.e. above or below 4 Mc/s.

2 TRANSMITTER DIFFERENCES

The variations in frequency range between the HS.71 and HS.71A transmitters cause three main differences:

- (a) in the unit identities
- (b) in the intermediate frequencies
- (c) in the r.f. tuning and loading circuit components

The differences in the unit type numbers used in HS.71 and HS.71A are clearly shown in List 2 at the front of the handbook and Table 1 following gives the differences in intermediate frequencies. The variations in r.f. tuning and loading components are covered in Section 3 (Description of Equipment).

Table 1

List of Ancillary Units and Intermediate Frequencies

HS.71			HS.71A		
Type of Service	Aux. Unit	I.F. (Mc/s)	Aux. Unit	I.F. (Mc/s) (Above 4 Mc/s fRAD)	I.F. (Mc/s) (Below 4 Mc/s fRAD)
FSK	HD.22	3.1	HD.22 Mod (Modified)	3.1	6.2
FSK Diplex	HD.22	3.1	HD.22 Mod (Modified)	3.1	6.2
	HD.61B	-			
ISB	HD.51	3.1	HD.51 Mod (Modified)	2.15	2.15
	SS.D2	3.1			
DSB			HD.22 Mod (Modified)	3.1	6.2
			HD.22 Mod (Modified)	3.1	6.2
CW			HD.22 Mod (Modified)	3.1	6.2

3 DESCRIPTION OF EQUIPMENT

3.1 GENERAL

The information given in A.P.2922E Vol.1, together with this Supplement, provides a complete manual on the Marconi Transmitters Types HS.71 and HS.71A. Where desirable, A.P.2922E Vol.1 has been amended and where repeated references would cause complicated notes to be added, this supplement has been referred to in A.P.2922E Vol.1.

3.2 DRIVE LEVEL CONTROL

In the HS.71 and HS.71A there exists the facility for feeding directly into Stage 4 a signal at radiated frequency, so that the transmitters may be used as four-stage power amplifiers. This external drive can be either at 20 watts if it is fed via an attenuator, or at 2 watts when it is fed direct to Stage 4. In the HS.71 the external drive level is controlled by a variable resistor on the front panel and the internal drive level by the MANUAL control on the Mixer Unit.

In the HS.71A and later HS.71 equipments the external drive level control has been moved directly to the grid of Stage 4, thus giving one front panel control for both drive sources. This slightly complicates the setting-up procedure when an internal drive is used, as this new level control is virtually in series with the MANUAL level control.

3.3 HARMONIC GENERATOR

The HS.71 and HS.71A transmitters have different intermediate frequencies; the HS.71 being 3.1 Mc/s and the HS.71A 2.15, 3.1 or 6.2 Mc/s. The use of 2.15 Mc/s is necessary to avoid the i.f. lying within the 2.5 - 4 Mc/s frequency band.

To allow the use of 3.1 Mc/s drive units (for economy reasons) with an HS.71A, the fundamental 3.1 Mc/s drive is used above 4 Mc/s radiated frequency, doubling to 6.2 Mc/s for radiated frequencies below 4 Mc/s. When this system is used monitoring exists only at radiated frequency, but equipment modified to RMC Mod. 1312, and using an I.F. of 3.1 Mc/s, will give an output at I.F. for external monitoring. Radiated frequencies between 2.9 and 3.3 Mc/s cannot, however, then be used. A crystal frequency table, to replace Table 2 below, faces Fig.1A in the main book.

The basic crystal formula of the transmitters is the same, but the primary crystal frequency range differs in each case. Table 2 shows the HS.71A crystal frequency range (the range for HS.71 is given in Table 4 in A.P.2922E Vol.1).

Table 2

Crystal Frequency Table

SWA Range	f xtal Mc/s	Function			fHG Mc/s	M
		V1	V2	V3		
4-8 Mc/s	4.65-7.15	Ampl	-	-	4.65-7.15	1
	3.575-4	Doubler	-	-	7.15-8	2
8-16 Mc/s	4.6.425	Ampl	Doubler	-	8 12.85	2
	3.2125-4	Doubler	Doubler	-	12.85-16	2
16.24.4 Mc/s	4-4.4625	Ampl	Doubler	Doubler	16-17.85	4

To restate the formula:

When fRAD is below 10 Mc/s

$$f_{\text{xtal}} = \frac{f_{\text{RAD}} + i.f.}{m} \text{ Mc/s}$$

When fRAD is above 10 Mc/s

$$f_{\text{xtal}} = \frac{f_{\text{RAD}} - i.f.}{m} \text{ Mc/s}$$

Where f_{xtal} = crystal frequency

f_{RAD} = radiated frequency

i.f. = intermediate frequency

m = multiplication factor found from Table 2

3.4 STAGE 5

The anode circuit of Stage 5 differs in the two transmitters in the function of SWA. A.P.2922E Vol.1 describes the HS.71 and the following describes the HS.71A.

The anode tuned circuit in HS.71A comprises inductor (L15), two ceramic capacitors (C32 and C38), SWA and the self-capacity of the circuit. On range 1 (L.F.) C32 tunes L15, on range 2 C32 and C38 in series tune L15 and on ranges 3, 4 and 5 the self-capacity of the circuit tunes L15.

3.5 STAGES 6 AND 7

To cover the lower frequencies of the HS.71A the coupling and tuning circuits of Stages 6 and 7 vary from those of the HS.71. This is achieved by detachable components which are either clipped or linked into circuit. Table 3 lists these components.

Table 3

Linked-in and Clipped-in Components

Circuit	Frequency Range	
	2.5 to 17 Mc/s	6.0 to 20 Mc/s
Stage 5/6 coupling C35/37, C39	All components in circuit	Remove C37 and open link LKD to isolate C39
Stage 6 filament choke L24/L25	Both in circuit	L25 short-circuited by LKC
Stage 6/7 coupling L44/L30	Both in circuit	L44 short-circuited by LKF
Stage 7 filament choke L35/L43	Both in circuit	L43 short-circuited by LKE

NOTE: All positions of the RANGE switches are used in the HS.71A transmitter.

3.6 MONITORING

The HS.71 and HS.71A monitor frequency is the same as the i.f. i.e., 3.1 Mc/s and 2.15 Mc/s respectively. When the HS.71A is used with an i.f. other than 2.15 Mc/s, monitoring is only available at radiated frequency except in equipments modified in accordance with RMC Mod. 1312, when monitoring is available on Monitor, Radio, Type 10160 at i.f. (3.1 Mc/s). Radiated frequencies between 2.9 and 3.3 Mc/s cannot, however, then be used.

At the lower frequencies of the HS.71A the level of pick-up is greater and therefore its monitor input is fitted with an attenuator comprising R136, R137 and R138.

4 SETTING-UP THE DRIVE LEVEL CONTROLS

The HS.71A has a single level control for use with either an internal or external drive. This has been mounted on the front of the 4th and 5th R.F. Unit. It permits the setting-up of the MANUAL level control (MIXER UNIT) or the external drive control (EXTERNAL DRIVE) at this stage so that all further adjustments of level may be carried out by the front panel control.

- (1) Set-up the I.F. drive to standard level.
- (2) Tune the Drive Level control to maximum.
- (3) Set the MANUAL control (MIXER UNIT) or the drive room control (EXTERNAL DRIVE) for approximately 4V output (on single tone) shown on STAGE 4 GRID peak voltmeter.

When the transmitter is switched on as in Section 9.1.8 of AP.2922E, check that the drive level is satisfactory. It is permissible to increase the preset mixer level control if necessary, but in the interests of linearity, the control should be adjusted to give as low an output from the mixer as possible.

The preset levels may also be adjusted at this stage after completing operation 3.

- (4) Set the MANUAL/REMOTE switch to REMOTE.
- (5) Set the preset controls for the frequencies in use.

(For final setting of the preset controls refer to Section 9.1.10 in AP.2922E).

5 ALIGNMENT OF THE MIXER UNIT

The input frequencies used in the alignment of the Mixer Unit of either transmitter vary and will further vary in the HS.71A depending on the i.f. in use. Table 4 lists the alignment frequencies.

Table 4
Alignment Frequencies

Section in A.P.2922E Vol.1	HS.71 Mc/s	HS.71A (using 2.15 Mc/s	HS.71A (using 3.1/6.2 Mc/s	Reference in A.P.2922E Vol.1
11.2.2 (ii)	3.1	2.15	6.2	*1
(v)	4/8	2.5/5	2.5/5	*2
(vi)	4/8	4/8	8/16	*3
	3.55	4.65	4.35	*4
	7.1	4.65	8.7	*5
(vii)	4	2.5	2.5	*6
(viii)	8/16	4/8	4/8	*7
	5.55	3.75	4.05	*8
If using 3.1/6.2 Mc/s i.f. remove the 6.2 Mc/s I/P and replace with a 3.1 Mc/s I/P				
	11.1	7.15	8.1	*10
(ix)	8	5	5	*11
(xi)	8/16	4/8	4/8	*12
	5.55	3.575	4.05	*13
	11.1	7.15	7.15	*14
(xii)	8/16	5/10	5/10	*15
	8	5	5	*16
(xiii)	6.45	3.925	3.45	*17
	12.9	7.85	6.9	*18
(xiv)	16	10	10	*19
(xvi)	8/16	4/8	4/8	*20
	6.45	3.925	3.45	*21
Apply a Single Tone input of 2.15 (3.1) Mc/s as in Section 11.2.2 (ii)				
	12.9	7.85	6.9	*23

Table 4 (Contd.)

Section in A.P.2922E	HS.71 Mc/s	HS.71A (using 2.15 Mc/s)	HS.71A (using 3.1/6.2 Mc/s)	Reference in A.P.2922E Vol.1
11.2.2 (xvii)	16/27.5	10/20	10/20	⌘24
	16	10	10	⌘25
(xviii)	16/24.4	16/24.4	16.24.4	⌘26
	6.1	4.4625	4.225	⌘27
	24.4	17.85	16.9	⌘28
(xix)	27.5	20	20	⌘29
11.2.3, line 1	3.1	2.15	3.1 or 6.2	⌘30
	5	8/16	5/10	⌘31
	9	4	5	⌘32
	10	16	10	⌘33
	13	16	10	⌘34
11.2.4, line 1	-	4/8	4/8	⌘35
	8/16	10/20		⌘36
	4	6.45	3.925	⌘37
	5	3.1	2.15	⌘38
	7	12.9	7.85	⌘39

6 HS.71 and HS.71A MODIFICATIONS

NOTE: *The modifications described in this section may affect any HS.71 or HS.71A equipment.*

6.1 BALANCED MIXER

Experience with the HS series of transmitters has shown that the gain of the CV138 valves in the mixer stage (V7, V8 Mixer Unit) is subject to variation during the first half hour when switched on from cold. The ruggedised version of the CV138, the CV4014 is not so affected and is now the preferred valve in this stage.

Early equipments may still be fitted with CV138 valves but all later equipments will have CV4014.

6.2 RECTIFIER AND CONTROL UNIT FAN

To meet climatic conditions where the Rectifier and Control Unit (RH) became overheated due to lack of ventilation a modification to fit a six inch fan in the roof of the cubicle was carried out. The fan operates from a 230V a.c. supply and is connected via a plug and socket across terminals 11 and 3 of the bias transformer TR5, thus using its primary winding as an auto-transformer on any voltage other than 230V a.c

Identity: Fan 40/60 c/s	WIS.8262/B-1-1
Plug 4-pin	WIS.3733/C-1-2
Socket 4-pin	WIS.3727/C-1-2

6.3 AIR FILTERS

To enable the air filters to be changed without switching off the transmitter (as in the case of the early equipments) the air intakes have been modified and fitted with external filters; the drawer type filters in the tops of the r.f. cubicles have been removed.

Identity: Filter, Air	W.65675-2-B
Filter, Air	W.65675-1-A

6.4 TIME SWITCH, FD

Later models of the transmitters have been fitted with a more robust time switch; the equipment operates as described in A.P.2922E Vol.1 with either switch.

Identity: Relay Time Switch	W.88142-B-1-A
-----------------------------	---------------

6.5 H. T. FUSES FS7, 8 and 9

The h.t. fuse rating in the series of transmitters has now been raised to 50A; some early equipments still retain the 35A fuses.

Identity: Fuse Cartridge, 50A	WIS.4806-B-1-Z
-------------------------------	----------------

6.6 INDICATOR LAMPS

Later equipments have had the 50V carbon lamps replaced with 6V tungsten lamps and dropper resistors.

Identity: Lamp No.2, Tung. Tub., 0.24W	PC.48601-2
Resistor w/w, 1.2 k Ω , $\pm 5\%$, 3W	WIS.7417-B-1-7

6.7 MIXER SUPPRESSOR BIAS

Later equipments derive the mixer suppressor bias from the stabilizer valve V10 in the rectifier and control unit instead of a tapping on R11 in that unit. The new arrangement supplies 75V to the level potentiometers in the mixer unit and avoids the double setting-up procedure.

9 kW H.F. I.S.B. TRANSMITTER

TYPE HS71/1

AP.116E-0232-1
Supplement 4

A.L.5 Apr. '67

THE MARCONI COMPANY LIMITED
CHELMSFORD
Printed in Great Britain

1967

CONTENTS

	Page
1 INTRODUCTION	1
4.2.4 Radio Frequency Unit (R.H.)	1
4.4.1 Rectifier and Control Unit (R.H.)	2
4.5.2 Amplifier Stages 4 and 5	2
4.5.3 Amplifier Stage 6	2
4.5.4.1 Reflectometer Test Controls Unit	2
4.5.4.2 Coupler Units Type 2685P	3
6.2.7 Stage 6 (Grid current trip)	3
6.2.8 Stage 6 Output Circuit	3
6.2.10 The Output Circuit	4
6.3.3.1 Grid Trip and Arc Protection	4
8.9 ADJUSTMENT OF REFLECTOMETER	5
Graph showing Relationship of V.S.W.R. and Reflection	6
8.10 SETTING UP THE REFLECTOMETER TRIP LEVELS	7
8.11 STAGE 5/6 COUPLING CAPACITOR	7
8.12 CHECKING DISTORTION	8
8.13 NEUTRALIZING STAGE 5	8
8.14 ADJUSTING STAGE 6 AND 7 GRID TRIP CIRCUIT	9
8.15 CHECKING THE ARC SUPPRESSION	9

CONTENTS (Contd.)

	Page
9 TUNING HS71/1	10
9.1 C.W. OPERATION	10
9.1.1 Calculation of Harmonic Generator and Crystal Drive Frequency	10
9.1.2 Initial Settings	10
9.1.3 Tuning the Harmonic Generator	11
9.1.4 Tuning the Mixer and Stages 1, 2 and 3	11
9.1.5 Tuning Stage 4	12
9.1.6 Tuning Stage 5	12
9.1.7 Tuning Stage 6	12
9.1.8 Tuning Stage 7	12
9.1.9 Final Tuning	13
9.1.10 Setting up Mixer Preset Level Controls	14
9.2 I.S.B. ADJUSTMENT	14
9.2.1 Tuning	14
9.2.2 Adjustment of I.S.B. Linearity	15
9.3 D.S.B. SIGNAL ADJUSTMENT	16
11.4 R.C.U. FAN MOTOR MAINTENANCE	16
12.2 RECALIBRATION OF R.F. POWER METER	17

9 KW H.F. 1.S.B. TRANSMITTER
TYPE HS71/1

1 INTRODUCTION

This supplement covers those major differences between HS71 and HS71/1 transmitters which cannot conveniently be covered in the main handbook. To facilitate cross reference, paragraphs in this supplement are given the same numbers as those paragraphs in the main book which have the same heading.

The HS71/1 transmitter is a modified version of the original HS71 type, from which it differs by having:-

- (a) 50 ohm coaxial output, and in-built reflectometer facilities.
- (b) an additional cooling fan (230V a.c., mounted on the roof of the right-hand Rectifier and Control Unit).
- (c) interlock pilot relay.
- (d) low air-pressure trip switches in the Stage 6 valve compartment.
- (e) feeder arc suppression circuits.
- (f) transmitter trip on excessive Stage 7 grid current.
- (g) variable coupling between Stages 5 and 6.

4.2.4 Radio Frequency Unit (R.H.)

The following additional panel, with controls as indicated, is mounted at the front of the right-hand Radio Frequency Unit in HS71/1:-

Reflectometer Test Panel

OVERLOAD TEST switch	SWS
ADJUST TEST CURRENT Potentiometers	
Forward	RV4
Reflected	RV5
FEEDER POWER SWITCH	SWT

4.4.1 Rectifier and Control Unit (R.H.)

In HS71/1 a 230V ventilation fan, X3, is fitted on the roof of the cubicle. The fan operates from a 230V a.c. supply and is connected via tagboard TB9 to terminals 11 and 12 of the bias transformer TR5, thus using its primary winding as an auto-transformer on any voltage other than 230V a.c.

4.5.2 Amplifier Stages 4 and 5

In HS71/1 the Stage 5 output coupling capacitor C35 forms a variable input capacity potentiometer with C45 in Stage 6. Once C35 is set up its setting holds good over the whole frequency range.

An input attenuator for an external drive unit of radiated frequency is mounted on the underside of this unit and the soldered connections to it must be modified when using a low external drive. For further details see Fig.16B.

4.5.3 Amplifier Stage 6

Above the Stage 6 valve cathode compartment is fitted the air switch, SWU, which is a differential switch having two nozzles: High Pressure and Low Pressure. The high pressure nozzle is connected to the cathode compartment and the low pressure nozzle to the anode compartment. The switch which is set to close at a pressure of 1.2 inches w.g. minimum and open at 0.8 inch w.g. minimum, is connected in the sequential control circuit to protect the equipment against loss of air cooling. If insufficient air pressure develops during switching on it remains open, causing the transmitter to remain off.

If the transmitter trips off or fails to switch on due to loss of or no air pressure, the air filters of both cabinets should be removed and cleaned as indicated in Section 11.7 of the parent handbook.

4.5.4.1 Reflectometer Test Controls Unit

This unit contains the test trip controls and the operating controls of the feeder power meter. It supplies the 6.3V a.c. for the REFLECTOMETER TRIP lamp on the meter facia panel.

A list of front panel controls is given in Section 4.2.4. in this Supplement.

4.5.4.2 Coupler Units Type 2685P

Component layout: Fig.1 in Supp.2.

The assembly consists of a $9\frac{1}{2}$ inch length of feeder outer, of 2 inch inside diameter, the ends being split for clamping to the adjacent feeder outers, and carrying a plate on which components are mounted. The inner conductor is held within the outer by disc insulators and the adjacent feeder inners are pushed into spring sockets projecting through these insulators.

The two directional couplers are let into holes in the plate and wall of the coupler assembly. Depth of penetration is determined by a collar held by grub screws; after setting to the correct depth and rotating to the correct position, the couplers are locked in position by grub screws in the bosses on the casting. On no account should their positions be altered. Three potentiometers are supported by a bracket at one side; their spindles are locked and should not be disturbed except when resetting the SWR type level. A P0 type jack is mounted on a bracket at one end and the trip relays are at the other. Adjacent to the relay position is a hole in the plate, closed by a hexagonal-headed bolt, or a rubber plug. For permanent wiring to the assembly the bolt or plug is removed and the wires are taken out through the hole. A cover fits over the assembly, held by a single screw at the front, and containing an outlet for the P0 type jack.

6.2.7 Stage 6 (Grid current trip)

The cathode circuit of V5 in HS71/1 is grounded via the centre tap of RV1(7J) and the cathode current meter shunt R22(8J). The grid is earthed to r.f. by C43 and C44, and C48 and C49. Grid bias is applied via L18(5J), the grid current meter M7 and its shunt R23 from the R.C.U. In the R.C.U. the bias supply is connected via overload trip relay OG (see Fig.23B). It has been found that many feeder faults cause the valve to unload resulting in low anode current and consequently high grid current and grid dissipation. Therefore this excessive grid current causes relay OG to operate starting h.t. trip circuit sequence described in Section 6.3.3 of the parent handbook.

6.2.8 Stage 6 Output Circuit

C40 and R67 are components of the Stage 6 output tune capacitor arc suppression circuit. This circuit is shown more clearly on Fig.23B and operates as follows. The circuit is raised to a potential of -50 d.c. by connection via the overload trip relay OG. Whilst the transmitter is operating correctly C40 earths the centre point of C64 to r.f. and R67 provides a static leak. On an arc occurring on C64 the arc provides a d.c. path of low resistance, thus resulting in sufficient d.c. current passing through OG to energize it, thereby starting the h.t. trip circuit sequence described in Section 6.3.3 in the parent handbook.

6.2.10 The Output Circuit

The output circuit matches the final stage output to a 50 ohm coaxial feeder. The tuning of the coupling coil L34 is done by C90, a gas-filled variable capacitor. On the lowest frequency ranges (Ranges 1 and 2) L37 is in series with L34, on Range 3 only C90 tunes L34 and on Ranges 4 and 5 additional parallel inductors L38 and L39 are introduced to the circuit.

All these circuit changes are made by SWR controlled by the STAGE 7 and OUTPUT RANGE control on the front panel.

An arc suppression circuit similar to that provided in Stage 6 is fitted. The 50V d.c. is connected via L16 to the coupling coil L34. The capacitors C102 and C103 isolate the feeder and capacitors C98 and C99 break the d.c. circuit through L38 and L39. If an arc occurs from any part of the feeder circuit to earth the relay OL in the R.C.U. will cause the main h.t. to be switched off (see Fig.23B).

6.3.3.1 Grid Trip and Arc Protection

Circuit Diagram Fig.23B.

Stage 6 and Stage 7 are provided with feeder arc protection and grid current trip circuits.

A high speed relay with two separate windings is used for each stage (OG and OK). One winding is connected in series with the grid circuit of the valve(s) and the other into the arc circuit. When this high speed relay operates its contact causes a slave relay (OJ or OL) to operate and lock itself on. This relay breaks the supply to MC switching off the main h.t. and another contact operates OR to light the overload lamp.

As the two stage circuits are similar Stage 6 will be described first with the Stage 7 differences enumerated after.

When a condition of high grid current prevails coil 3/2 of relay OG will be energized, the level at which this takes place being set by RV7.

OG1 will change over and energize relay OJ.

OJ1 opens de-energizing the main h.t. contactor MC.

OJ2 closes to energize the overload lockout relay OR.

OJ3 closes to lock-on relay OJ and thus OR.

OR operates as previously described.

In addition to Stage 6 basic circuit, on Stage 7 a switch, SWR, and two resistors, R56 and R57, are included. This circuit provides a trip level suitable for C.W./F.S.K. or for I.S.B.

If an arc develops across the feeder tuning capacitor C64, it forms a low resistance path for the 50 d.c. potential to which the output circuit has been raised by its connection via coil 4/1 of relay OG. Relay OG is energized and the trip circuit operates.

8.9 ADJUSTMENT OF REFLECTOMETER

The Reflectometer coupler is adjusted before leaving the factory and should normally need no further attention. In certain circumstances when components such as the relay or variable resistors have been replaced the d.c. circuits may be readjusted. Under no circumstances should an attempt be made to adjust the probes. To make the adjustments an accurately matched load of 50 ohms is necessary.

NOTE: *This is a low level device being used in a strong r.f. field so that if trouble is experienced when first setting up the earthing of the unit and screening of cables should be checked.*

1. Remove the lead from TB1(6) on the coupler unit to immobilise the trip circuit.
2. Tune up 16 Mc/s (3.225 Mc/s Crystal) on single tone; exact adjustment of power level is not necessary, 5-7 kW will be sufficient. Measure the power in the load and note the R.F. POWER meter reading. Depress the power switch and check the reading on 'Backward' is practically zero. Switch off, remove the panel from behind the meter panel of the right-hand R.F. Unit to gain access to the directional coupler unit. Adjust RV2 to correct the meter reading of forward wave power. Clockwise increases the reading and vice versa.
3. Switch off, apply a short circuit across the feeder in place of the load. Switch on with low h.t. and zero drive. Apply a very small amount of drive. This should be just sufficient to give a small deflection of the power meter switched to read forward wave power. Retune Stage 7 anode circuit and the feeder circuit, taking care to keep the drive as low as possible for tuning purposes. Increase the drive till the power meter reads 2 kW. Switch the power meter to read backward wave power and note the reading. RV3 in the coupler unit must now be adjusted to give the same reading of backward power as is indicated in the forward wave position. Great care must be taken during these adjustments to ensure that excessive drive is not applied to the transmitter as damage is caused by excessive circulating currents or voltages.
4. Replace the lead in TB1(6)

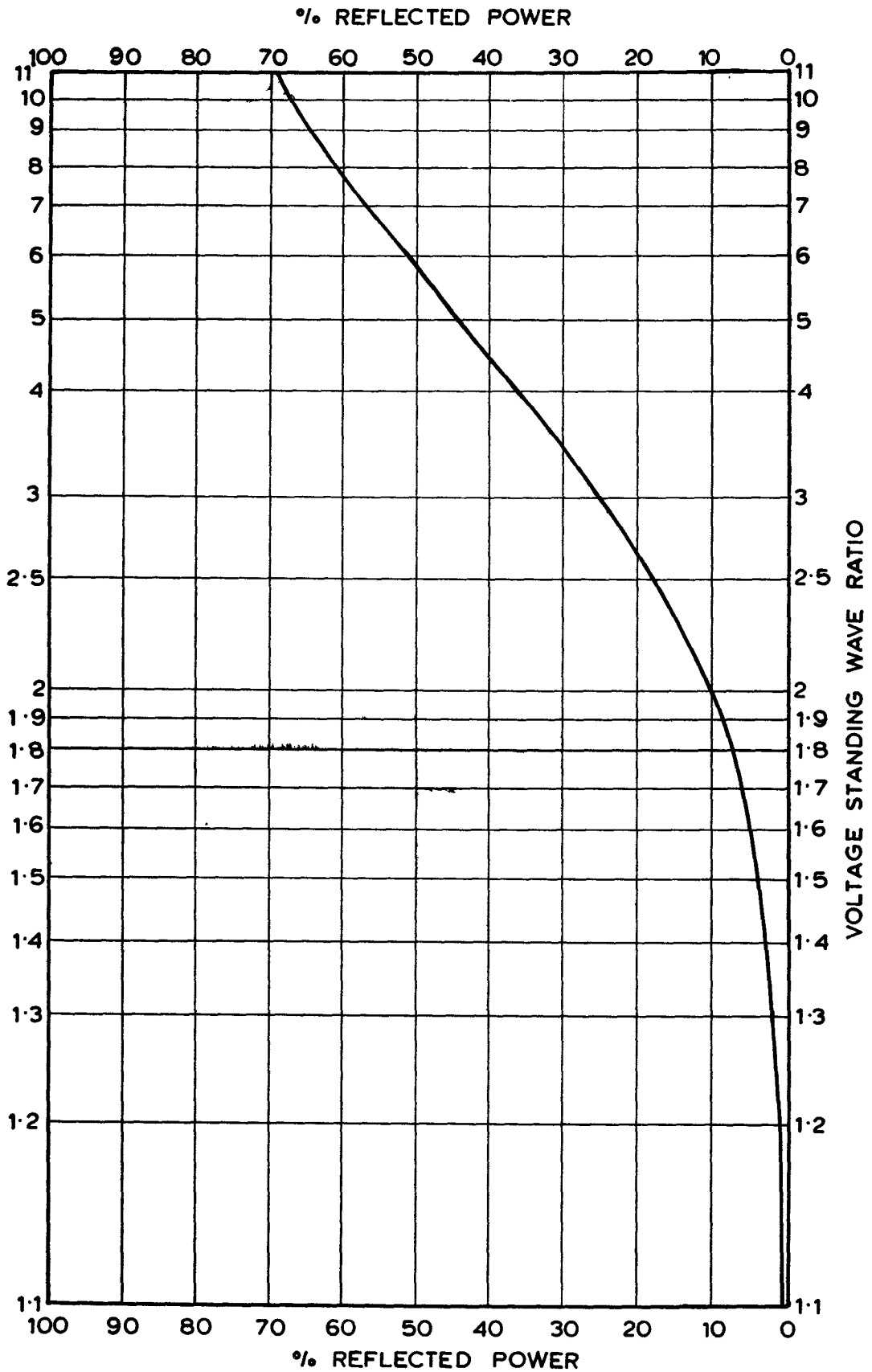

Fig.1 Graph Showing Relationship of V.S.W.R. and Reflection
T30-2763 Sh.2 Iss.1

8.10 SETTING UP THE REFLECTOMETER TRIP LEVELS

Normally the Reflectometer is set to trip at SWR of 2:1; to do this switch on the control supplies and proceed as follows:

- (a) Set the 'FORWARD' and 'REFLECTED' controls (RV9 and RV10 respectively on the REFLECTOMETER TEST CONTROLS panel, fully clockwise (no output).
- (b) Depress the OVERLOAD TEST switch SWS.
- (c) Adjust the 'FORWARD' control until the R.F. POWER meter indicates 7 kW and the 'REFLECTED' control (read with the 'FEEDER POWER' switch depressed) until the meter indicates 800W.
- (d) Adjust RV1 in the Coupler Unit until the REFLECTOMETER TRIP lamp just lights and the audible alarm is initiated.
- (e) Press the H.T. OFF button to reset the trip circuit.
- (f) Turn REFLECTED Control (RV10) fully counterclockwise. Depress the OVERLOAD TEST and FEEDER POWER switches and increase the R.F. POWER meter reading from zero to the point at which the trip operates. This should be approximately 800W.
- (g) Finally turn the controls RV9 and RV10 fully anticlockwise.

NOTE: *Reflection Coefficient: $K = \sqrt{\frac{\text{Reflected Power}}{\text{Forward Power}}}$*

$$\text{Standing Wave Ratio} = \frac{1 + K}{1 - K}$$

8.11 STAGE 5/6 COUPLING CAPACITOR

The adjustment of the coupling capacitor C35 is normally carried out before despatch. The initial setting will be found on Test Report and at this stage it is only necessary to check that the capacitor has not been moved. If the Test Report is not available set the capacitor 9 turns from maximum.

This component should be set to give the best linearity performance of the transmitter. The capacitance required will normally result in a Stage 5 cathode current of approximately 130 mA with a Stage 7 grid current of 250 mA and cathode current of 2.65A on C.W./F.S.K. service.

When first adjusting for minimum distortion settings between 8 and 10 turns should be examined.

A slight change of setting may be necessary when Stage 5 valves are changed.

8.12 CHECKING DISTORTION

Connect the U-link on the mixer monitor frequency changer to the STAGE 7 monitoring point and the U-link on Stage 7 to the FEEDER monitoring point.

Check the distortion on the Spectrum Analyser, or the monitor receiver in the I.S.B. drive rack as explained in the relevant manual.

Adjust the Stage 5 feedback potentiometer for minimum distortion indicated on the monitor receiver. If the distortion is higher than the required figure it may be necessary to adjust the STAGE 6 COUPLING slightly; as a general rule, for best results, coupling should be slightly greater than optimum. After any adjustment of coupling readjust the feedback potentiometer.

When tuning up for the first time it will be found helpful to use a c.r.o. to display the r.f. waveform, when the effects of over-coupling and under-coupling will be clearly seen. If the coupling is too light there will be a tendency for the waveform to flatten, increasing the coupling overcomes this tendency but of course Stage 6 loss increases, so that it should not be overcoupled more than necessary.

8.13 NEUTRALIZING STAGE 5

Neutralizing should be carried out when the set is first tuned and subsequently should only be necessary after changing valves. It should be carried out at 20 Mc/s, or alternatively at the highest frequency normally used up to 22 Mc/s.

Either of two methods may be used.

- (a) Adjust Stage 5 tuning control for minimum cathode current. With the 3.1 Mc/s level reduced, detune on either side of the tuning point and note Stage 6 grid current. If Stage 5 is properly neutralized the dip in cathode current will coincide with a peak of Stage 6 grid current. If there is an increase of Stage 6 grid current on one side of the tuning point, rotate the Stage 5 neutralizing control a little in the same direction as the tuning control was turned to give the rise. Retune Stage 4. Swing the tuning control through the tuning point again and note cathode current and Stage 6 grid current. Continue adjusting the neutralizing control and checking the currents until the dip in Stage 5 cathode current and the rise in Stage 6 grid current exactly coincide.

NOTE: *It is important to retune Stage 4 after each adjustment of the neutralizing control.*

(b) Completely detune Stage 5

Adjust the level control to give approximately 100 mA Stage 5 cathode current. Tune through minimum cathode current, then detune completely on the other side of the tuning point and note the current.

Adjust the neutralizing control until the cathode current reading is the same when the stage is completely detuned on either side of the tuning point, readjusting Stage 4 tune as necessary.

8.14 ADJUSTING STAGE 6 AND 7 GRID TRIP CIRCUIT

With the transmitter tuned as in Section 9.1.9, reduce the drive level and feeder coupling maintaining Stage 7 grid current at about 200 mA. Now turn drive level to zero.

Turn the Stage 7 grid current trip switch to 'C.W./F.S.K.'. Increase the drive level to 600 mA or till the trip operates. If necessary adjust the control RV8 till the relay operates with a grid current of 600 mA. This must be done in steps, the transmitter being switched off each time to gain access to RV8, situated at the rear of the R.C. Unit.

Check the current at which the relay operates on the 'I.S.B.' switch position. This should be approximately 350 mA.

8.15 CHECKING THE ARC SUPPRESSION

Switch off and connect a short circuit across one half of the Stage 6 output tuning capacitor. It should now be impossible to bring on the main h.t.

Switch off and remove the short.

Connect a short circuit across the feeder circuit tuning capacitor. Again it should be impossible to bring on the main h.t.

Switch off and remove the short.

9 TUNING HS71/1

When the transmitter is first installed, and after being closed down for maintenance, it should be checked as described in Section 8 before being tuned. Tuning may conveniently be carried out using a test load, though this is not essential if an aerial is available.

Test equipment required: Spectrum Analyser OA1094 (AP.103540)
Artificial load for transmitter (50 ohms)

9.1 C.W. OPERATION

9.1.1 Calculation of Harmonic Generator and Crystal Drive Frequency

For any radiated frequency in the range 4-27.5 Mc/s the frequency multiplication required in the harmonic generator stages of the mixer unit at the crystal oscillator frequency to be used is calculated as follows:-

fRAD = Final radiated frequency in Mc/s.

fx = Frequency multiplication in harmonic generator stages of the mixer unit.

3.1 = 3.1 Mc/s keyed signal to mixer from keying unit.

When fRAD is less than 10 Mc/s.

m = 2

$$fRAD = 2fx - 3.1 \text{ Mc/s or: } fx = \frac{fRAD + 3.1}{2} \text{ Mc/s.}$$

When fRAD is between 10 and 17 Mc/s

m = 2

$$fRAD = 2fx + 3.1 \text{ Mc/s or: } fx = \frac{fRAD - 3.1}{2} \text{ Mc/s}$$

When fRAD is greater than 17 Mc/s.

m = 4

$$fRAD = 4fx + 3.1 \text{ Mc/s or: } fx = \frac{fRAD - 3.1}{4} \text{ Mc/s.}$$

An explanation of the manner of operation of the harmonic generator and the reasons underlying the selection of the primary crystal frequencies appears in Section 6.2.2 of the parent handbook.

9.1.2 Initial Settings

Set up all tuning controls and range switches to the position shown on the calibration curves for the required frequency, or alternatively from the logged figures. Connect up the i.f. drive (3.1 Mc/s) set to give one tone, and the HG input.

The adjustment of C35 is normally carried out before despatch and therefore only checking described in Section 8.11 should be necessary. Should, however, the setting have been disturbed or the capacitor replaced, it should now be set to 9 turns from maximum and finally set as in Section 8.11. If the Test Record is available set it to the figure given therein.

9.1.3 Tuning the Harmonic Generator

The primary oscillator equipment should be set up to provide crystal drive frequencies for the six different radiated frequencies. The crystal oscillators are selected by operation of the FREQUENCY SELECTOR switch.

Switch the auxiliary h.t. on as described in Section 10.1.

Turn the FREQUENCY switch to Wave 'A'.

Turn the MANUAL/AUTO switch to AUTO.

Return the MANUAL/AUTO switch to MANUAL.

Set the ST.4 INPUT link to INT. MIXER.

Check that the FREQUENCY switch on the HD21 rack has selected the appropriate primary drive frequency, i.e. frequency 'A' calculated in Section 9.1.1.

Set the HG METERING switch to the MIXER position and set the MIXER and MONITOR METERING switch to the 'V7/V8' position (mixer cathode current).

Adjust the HG TUNE control for maximum reading on the meter.

Set the front panel DRIVE LEVEL control to maximum.

9.1.4 Tuning the Mixer and Stages 1, 2 and 3

Set the mixer suppressor bias MANUAL/REMOTE switch to MANUAL and set the MANUAL control to mid-position.

Adjust the MIXER TUNE control for maximum reading on the STAGE 4 GRID PEAK VOLTS meter. Check the scale reading of the MIXER TUNE against the calibration curves to ensure that the desired radiated frequency has been obtained, as it will in some cases be possible to tune the mixer to $f_{HG} - 3.1$, $f_{HG} + 3.1$ and to f_{HG} itself, depending on the range.

Adjust the MANUAL control for a reading of 4 volts.

When the MANUAL control has been set up to the level given above the Mixer Unit may be returned to the cabinet and all further level adjustments made with the DRIVE LEVEL control on the front panel.

When the transmitter is completely operational as at Section 9.1.9 check that the drive level is satisfactory. It is permissible to increase the preset mixer level (MANUAL) if necessary, but in the interests of linearity, the control should be adjusted to give as low an output from the mixer as possible.

9.1.5 Tuning Stage 4

Adjust the STAGE 4 TUNE control for maximum reading on the STAGE 5 GRID PEAK VOLTS meter. If the tuning point is found to be very close to a microswitch operating point, a second tuning point on the adjacent range should be used.

9.1.6 Tuning Stage 5

Reduce to zero the Stage 4 grid volts by the level control. Turn the H.T. VOLTS switch to LOW and press the H.T. ON button.

Increase the level to give Stage 5 cathode current of approximately 50 mA.

Adjust STAGE 5 TUNE for minimum Stage 5 cathode current, keeping the drive level adjusted so that Stage 6 cathode current does not rise above 0.6A or the grid current above 100 mA.

9.1.7 Tuning Stage 6

Set Stage 6 coupling to minimum.

Adjust the level to obtain 0.3 amp Stage 6 cathode current.

Adjust STAGE 6 TUNE for minimum cathode current.

Increase the coupling until the Stage 6 grid current just begins to fall.

Adjust Stage 6 OUTPUT TUNE for maximum Stage 7 grid or cathode current, adjusting the drive level to ensure that the grid current never rises above 200 mA.

NOTE: *STAGE 7 INPUT TUNE should always be left at the setting shown on the Calibration Chart.*

Recheck Stage 5 tuning for minimum Stage 5 cathode current and Stage 4 tuning for maximum Stage 5 grid peak volts, keeping the drive level to Stage 6 below 100 mA.

9.1.8 Tuning Stage 7

Reduce FEEDER COUPLING to minimum and adjust the drive level and if necessary Stage 6 coupling slightly to give a Stage 7 cathode current of approximately 0.6 amp.

Adjust STAGE 7 TUNE for minimum cathode current, taking care that as the dip in cathode current is approached the grid current does not rise above 200 mA using drive level control.

Keeping Stage 7 grid current below 50 mA with the level control, gradually increase the coupling (FEEDER COUPLING) to the point where Stage 7 grid current starts to fall.

Adjust the feeder tuning control (FEEDER TUNE) for maximum feeder power as indicated on the R.F. POWER meter. Readjust STAGE 7 ANODE TUNE control for minimum cathode current. Increase the feeder coupling until the power meter reading tends to a maximum, retuning Stage 7 anode with each adjustment of the coupling.

9.1.9 Final Tuning

Reduce the Stage 4 input level to 0 volts and turn the h.t. volts switch to FULL. Increase the level so as not to exceed 200 mA Stage 7 grid current or 100 mA Stage 6 grid current.

Adjust STAGE 6 OUTPUT TUNE towards peak grid current on Stage 7. Readjust STAGE 6 TUNE for dip in cathode current. Repeat these two adjustments alternately until Stage 7 grid current falls whichever way the output tune is adjusted, indicating that the tune of the output and anode circuits are coincident. (When the dip in cathode current is rather indeterminate anode tune may be observed by the peak of St.6 grid current.)

Check the grid and cathode currents of Stage 6 when the input is adjusted to give 2.6 amp Stage 7 cathode current. Provided these figures are approximately 40 mA and 0.6 amp respectively, proceed to tune and load Stage 7 as follows.

Adjust the FEEDER TUNE towards peak r.f. power meter reading and then adjust STAGE 7 ANODE TUNE to minimum in Stage 7 cathode current (this point is often better indicated by the peak in Stage 7 grid current). Repeat these adjustments alternately until the power meter reading falls whichever way the FEEDER TUNE is moved, indicating that anode and feeder circuits are in tune together.

Now adjust the level to give 3.25A cathode current to Stage 7 and note Stage 7 grid current and Stage 6 grid and cathode currents. These should be approximately as follows:-

Stage 7 Ig: 450/550 mA
Stage 6 Ic: 0.5/0.7A
Stage 6 Ig: 40/60 mA

If these feeds do not lie within these limits it will be necessary to adjust STAGE 6 COUPLING and/or FEEDER COUPLING. Coupling too low is indicated by low cathode and high grid current; coupling too great by high cathode and low grid currents. After each adjustment of the coupling the anode and output circuits must be readjusted as described above to achieve coincident tune.

Recheck the settings of the anode tuning controls of all stages and finally neutralize Stage 5 if necessary as described in Section 8.13.

- NOTES (i) *The process of tuning the output circuits of Stages 6 and 7 described above is most important on Range 5 where the adjustment of the coupling coils causes the greatest percentage change of circuit inductance as the 'telescope' rods shorten.*
- (ii) *Stage 5 cathode current will normally be between 110 and 140 mA.*
- (iii) *Check that St.71c + St.61c + St.51a - (St.61g + St.71g) \neq 3.75A.*
- (iv) *The R.F. POWER meter has an accuracy of $\pm 1.5\%$ and the level should be set according to the valve figures quoted and not to give a particular power indication.*

9.1.10 Setting up Mixer Preset Level Controls

Turn the MANUAL control to minimum and the front panel DRIVE LEVEL control to maximum.

Turn the frequency 'A' potentiometer to zero.

Having tuned the transmitter on working frequency 'A' turn the mixer bias MANUAL/REMOTE switch SWF to REMOTE. Adjust the 'A' preset level control to obtain full output for $\frac{1}{4}$ W input. If this is done in each working frequency, the correct level will then be automatically selected for each of the six positions on the frequency selector switch.

Finally, log all meter and scale readings for future reference.

9.2 I.S.B. ADJUSTMENT

9.2.1 Tuning

Proceed as for C.W./F.S.K. operation up to Section 9.1.8 except that in Section 9.1.2 apply a two-tone signal at 3.1 Mc/s from an i.s.b. drive unit, at 0.25W.

For final adjustment of the loading of Stages 6 and 7 (Section 9.1.9) set the grid and cathode currents by increasing the output and feeder coupling as follows:-

- Stage 6: Grid current 20-30 mA, cathode current 0.5-0.68
Stage 7: Grid current 220-280 mA, cathode current 2.5-2.65

NOTE: *Stage 5 cathode current will be approximately 80-110 mA.*

It will be observed that all other figures will also be correspondingly lower than on c.w. operation as shown on the chart of typical power figures.

9.2.2 Adjustment of I.S.B. Linearity

1. Connect the spectrum analyzer to the monitor distribution point marked 'STAGE 7' on the front of the mixer unit and tune up to the 21 Mc/s signal.
2. Note the power meter reading to give a subsequent check of the power level.
3. Detune Stage 5, moving the control in a counterclockwise direction, till its cathode current increases by 10 mA (this improves the linearity of the stage). If necessary increase the drive level to maintain the level of power output.
4. Adjust the Stage 5 feedback control to give the lowest level of i.ps, as indicated on the spectrum analyzer.
5. Check the i.ps for each level of drive in 2 dB steps down to -10 dB. In each case the highest i.p. should not exceed a level of -36 dB below the level of either tone.

It may be necessary to readjust the feedback to obtain a compromise of high and low drive levels. The worst condition is often when Stage 7 grid current is approximately 30 mA (-6 to -8 dB).

The grid and cathode current quoted in the previous section are not intended to be rigidly adhered to. Since the loading of Stage 6 and Stage 7 has a considerable effect on the linearity, the exact figures required to achieve a p.e.p. of 9.0 kW with distortion less than -36 dB will vary with each transmitter. The cathode current of Stage 5 should not be allowed to exceed 140 mA and the anode current of Stage 7 2.65A on a two-tone i.s.b. signal.

The distortion occurring around -6 to -10 dB will be found somewhat dependent on the bias of the stages. Stage 5 'space' current may be varied between 45 and 60 mA, Stage 6 between 0.2 and 0.3 amp, and Stage 7 between 0.5 and 0.7 amp if necessary to achieve the optimum performance.

The setting of Stage 7 input tune will be found to have a bearing on distortion at the lower end of the frequency range (4-7 Mc/s) and if the linearity specification cannot be achieved with the setting as shown on the calibration curve the position of the control should be altered slightly; more than 10 divisions in either direction should not be necessary. The order of improvement to be expected will be about 3 to 4 dB.

NOTE: *All figures and settings should be recorded.*

Pilot Carrier Compression

Set the i.f. generator to give -26 dB and one of the two tones at the level used to check p.e.p. Check that when the tone is switched off the change in pilot carrier level is less than 1 dB.

Noise Level

Switch on one tone and switch off the pilot carrier. Check on the spectrum analyser with the trace running at a 30-second period and the 6 c/s filter in circuit that every noise component is more than 44 dB below the level of the tone.

9.3 D.S.B. SIGNAL ADJUSTMENT

1. Set the Stage 7 grid-trip switch to I.S.B.
2. Adjust the carrier level by setting up the transmitter by a two-tone i.s.b. signal.
3. Apply the carrier via the d.s.b. equipment and adjust the gain of the mixer stage with the front panel drive control at maximum to give an output of 3.5 kW. Stage 7 grid and cathode currents will be approximately 150 mA and 2.3 amp respectively.

11.4 R.C.U. FAN MOTOR MAINTENANCE

Inspection will show that by undoing the motor fixing screws the motor and impeller can be removed for inspection and servicing.

When in constant use the motor should be removed for oiling every six months. Use no more than ten drops of thin high grade machine oil for each bearing. Access to oil holes is obtained by unscrewing the oiler plugs; that at the rear end is under the plastic end cover.

The fan is fitted with porous metal sleeve bearings having felt oil reservoirs. Care should be taken to avoid over-oiling.

The plastic components of the fan assembly can be washed in warm (not hot) water and soap, and polished with a dry cloth.

When Modification No. A.3977 has been incorporated, fan Identity WIS.8262/B Sh.1 Ref.1. is replaced by ventilating fan Ref. No. 10K/4140-99-633-2694. This requires bearing lubrication (34B/9100510 Grease XG271) to be replenished at six monthly intervals.

12.2 RECALIBRATION OF R.F. POWER METER

This recalibration may be carried out on site if there is available an accurately matched 50 ohm water-cooled test load (reflection coefficient less than 1%).

WARNING: *The setting of the directional coupler probes in the Coupler Unit must in no circumstances be altered. They are locked in position, cannot be reset without special equipment and should be returned to The Marconi Co. Ltd., for recalibration if they are disturbed or damaged.*

To recalibrate the meter proceed as follows:-

- (a) Connect the 50 ohm artificial load and ensure that its water-cooling supply is working.
 - (b) Remove the panel from behind the meter panel of the R.F. Unit, R.H., to give access to the Coupler Unit.
 - (c) Disconnect from the Coupler Unit the lead terminated at TB1(7). This will immobilize the tripping action of the Reflectometer Circuit.
 - (d) Tune the transmitter to 16 Mc/s (3.225 Mc/s crystal) on a single tone and adjust the power output to 5-7 kW. (Exact adjustment of power level is not necessary.)
 - (e) Depress the FEEDER POWER switch and check that the reflected power is practically zero, then release switch.
 - (f) Accurately measure the power in the load and adjust RV2 on the Coupler Unit so that the R.F. POWER meter reads correctly. Lock RV2.
 - (g) Switch off and efficiently short-circuit the feeder at a convenient point beyond the Coupler Unit (i.e. towards the aerial).
 - (h) Switch on the transmitter with low h.t. and zero drives.
 - (j) Apply the sufficient drive to give a small deflection of the R.F. POWER meter. Return Stage 7 anode circuit and the feeder circuit, taking care to keep the drive as low as possible for tuning purposes. Increase the drive until the R.F. POWER meter reads 2 kW.
 - (k) Depress the FEEDER POWER switch to 'REFLECTED' and note the reading. RV3 (Coupler Unit) must then be adjusted to give the same reading of REFLECTED power as was indicated when the switch was in the FORWARD position.
- Great care must be taken during these adjustments to ensure that excessive drive is not applied.
- (l) Switch off the transmitter. Remove the short-circuit from the output feeder and connect the aerial feeder. Reconnect the lead that was removed from TB1(7) on the Coupler Unit. Replace the panels that have been removed to give access to the Coupler Unit.